

IPC-01-01

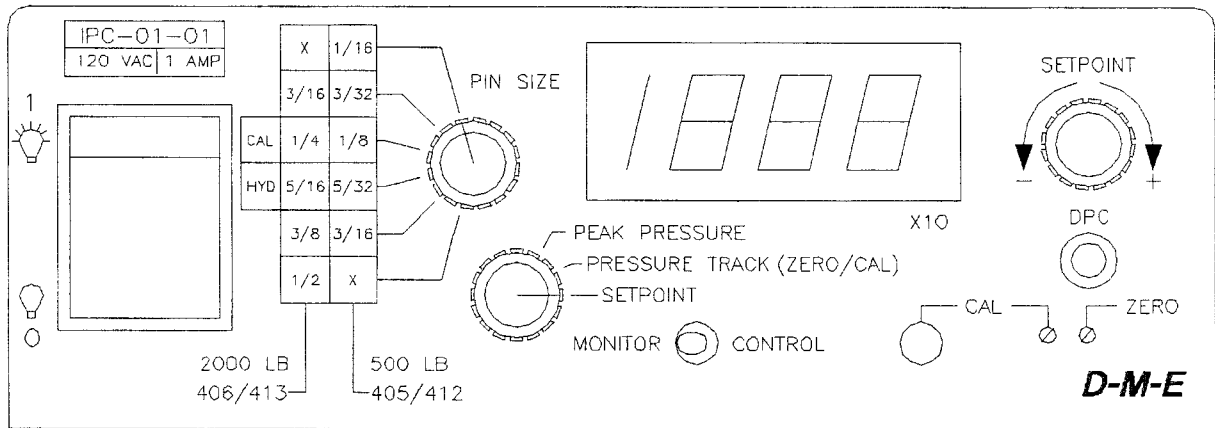

Pressure Control Unit with Digital Display

User's Manual

D-M-E Company

D-M-E Standard

Pressure Control Unit with Digital Display

IPC-01-01

GENERAL DESCRIPTION

The IPC-01-01 Pressure Control unit is a self-contained pressure monitoring/controlling unit that is used in conjunction with pressure sensors, sold separately, by D-M-E Company. The pressure sensors consist of a resistive Wheatstone bridge configuration, (strain gages), that measure approximately 350 ohms and can measure pressures of 500 pounds or 2000 pounds depending on the sensor purchased. This unit can be used as a monitor only or for closed loop control situations used with those sensors. This unit also provides the user with an analog output of 0-5 VDC to be used with strip chart recorders. The pressure is read directly on the digital display in pounds per square inch, (PSI), using a multiplication factor of times ten.

OPERATION:

MONITOR MODE: When operated in this mode, the unit will operate as a monitor only where the pressure will be displayed on the digital readout in PSI.

CONTROL MODE: When operated in this mode, the unit will control pressure in a closed-loop. When an injection forward signal is provided to this unit in the form of a dry contact closure, the unit will then begin to control pressure about a specific setpoint pressure. When the actual measured pressure exceeds the setpoint pressure a relay is energized and a set of contacts are provided to the user.

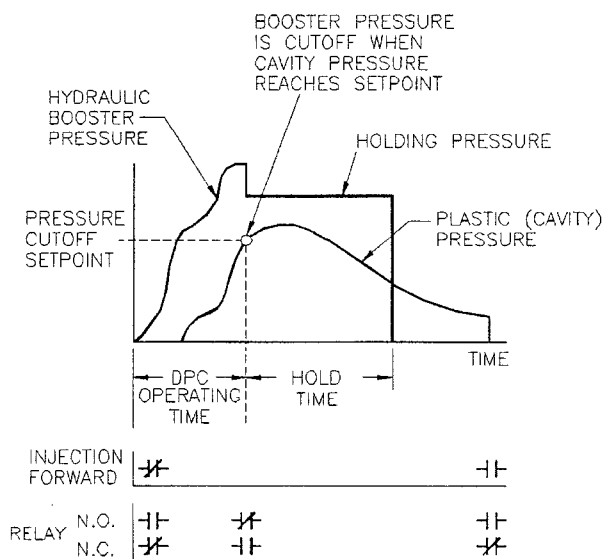

Figure 1. - Closed-Loop Pressure Control

FEATURES:

- Standard 350 ohm Wheatstone bridge pressure sensor input or load cell input
- High speed analog signal conditioning circuitry
- Digital display with continuous pressure readout
- The ability to display peak pressure readout
- 0-5 VDC analog output for strip chart recorders
- Selectable pin size
- Variable pressure setpoint
- Dynamic pressure control (DPC) acknowledgment via LED illumination
- Relay output for closed-loop control of pressure
- Dry contact input for injection forward signal
- The ability to monitor or control at the flip of a switch

PERFORMANCE SPECIFICATIONS:

ACCURACY: Analog Output & Digital Display: +/-1% full scale. DP Control Setpoint: .8% full scale maximum.

REPEATABILITY: Analog Output & Digital Display: .5% full scale. Setpoint: .25% full scale.

ANALOG RECORDER OUTPUT: Proportional to cavity pressure. 5 VDC corresponds to 20000 PSI. Maximum Load: 1K ohm.

TEMPERATURE RANGE: 50 to 130°F

POWER REQUIRED: 120 VAC (96-132), 50-60 Hz

ZERO DRIFT, ANALOG-OUTPUT: Long term: .1%/month, With temperature: .1%/°F

OUTPUT CONTACT RATING: 1 amp max. 120V AC

OUTPUT VOLTAGE TO BRIDGE: 10 VDC with 350 ohm Wheatstone bridge

DIMENSIONS: 7.2"W x 2.7"H x 8.6"D (18.29 x 6.86 x 21.84 cm)

DIAGNOSTICS:

- -1 or 1 is displayed on digital readout
- ✘ **Troubleshooting-**
Sensor is not attached to unit
Broken wire in sensor

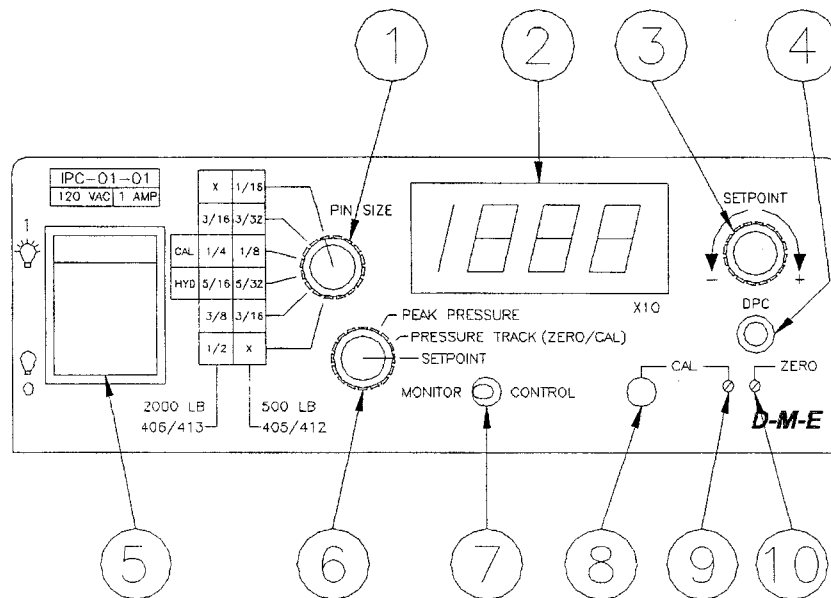

Figure 2. - IPC Front Panel Controls

- Sensor is malfunctioning
- Unit does not measure pressure correctly
 - ✘ **Troubleshooting-**
 - Pin size switch is in the wrong position
 - Unit requires calibration
 - Sticky or preloaded ejector pin
 - Sensor is malfunctioning
- DPC LED does not illuminate when controlling pressure
 - ✘ **Troubleshooting-**
 - Signal on pins 1 and 2 of Machine interface connector (injection forward signal) not present
 - Sensor is malfunctioning

INPUT SPECIFICATIONS:

POWER REQUIRED: 120 VAC (96-132), 50-60 Hz

INPUT SENSITIVITY: 2.0 mV/V - 3.3 mV/V

INJECTION FORWARD INPUT CIRCUIT: Dry contact closure

OVERLOAD PROTECTION:

1 AMP:Fuses are provided on both sides of AC line

TRANSIENT PROTECTION: dv/dt and transient pulse suppression included

POWER LINE ISOLATION: Transformer isolated from AC lines. Isolation voltage is greater than 2500 volts

OUTPUT SPECIFICATIONS:

ANALOG RECORDER OUTPUT: Proportional to cavity pressure. 5 VDC corresponds to 20000 PSI. Maximum Load: 1K ohm.

RELAY OUTPUT DELAY: 10 milliseconds.

RELAY CONTACT RATING: 1 amp, 120 VAC.

FRONT PANEL CONTROLS AND INDICATORS: (See Figure 2)

- 1. PIN SIZE:** Rotate this switch until the desired pin size is selected for the appropriate sensor selected.
- 2. DIGITAL DISPLAY:** Displays the selected pressure in pounds per square inch (PSI). Note: The display will show up to 1999 PSI this number must be multiplied times 10 to give the actual value of 19990 PSI.
- 3. SETPOINT:** Rotate the setpoint dial when the MODE switch above is in the SETPOINT position to display the desired setpoint pressure.
- 4. DPC:** When in "Control" this LED will illuminate when the unit has measured a pressure that is greater than the setpoint pressure.
- 5. POWER:** Press the button to the "1" position to turn the units power on. The "0" position is the off position.
- 6. MODE:** This switch selects the different operation modes. When an injection forward signal is present, Peak Pressure, when selected, displays the highest pressure achieved during the process run. Pressure Track, when selected, displays the actual pressure in real time. Setpoint, when selected, displays the setpoint pressure.
- 7. MONITOR/CONTROL:** When this switch is positioned in the monitor position, the unit will only monitor the pressure readings. When in the control position, the unit will control the pressure if the injection forward signal is present.
- 8. CAL BUTTON:** This button is used to calibrate a sensor. After zeroing a sensor, depress this button and adjust the CAL potentiometer to display the desired calibration value.
- 9. CAL POTENTIOMETER:** This potentiometer is adjusted after zeroing the unit for calibration of the sensor. Since each sensor is different, the unit must be calibrated for the sensor being used. Depress the CAL button and adjust this potentiometer to display the desired calibration value.

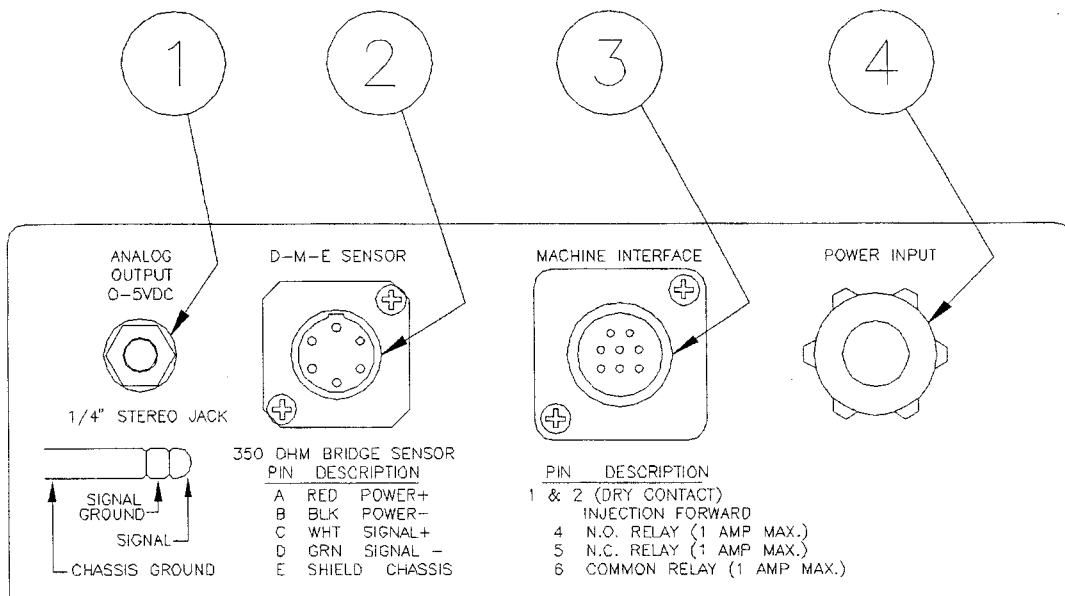

Figure 3. - IPC Rear Panel

10. ZERO POTENTIOMETER: After attaching a pressure sensor to the unit, you must zero the unit to display all zeros on the digital display.

ELECTRICAL POWER SPECIFICATIONS:

INPUT VOLTAGE: 120 VAC (96-132), (-20%, +10%)

FREQUENCY: 50/60 Hz

DC POWER SUPPLIES: Internally generated, regulated and compensated

UNIT POWER USAGE: Less than 5 watts.

DIMENSIONS: 7.2"W x 2.7"H x 8.6"D,
(18.29 x 6.86 x 21.84 cm)

NOTE: Use IPC-01-01 for 120 VAC operation. Use IPC-01-02 for 240 VAC operation.

FUSE REQUIREMENTS: (2) ABC-1 fuses (Note: (2) spare fuses included with unit).

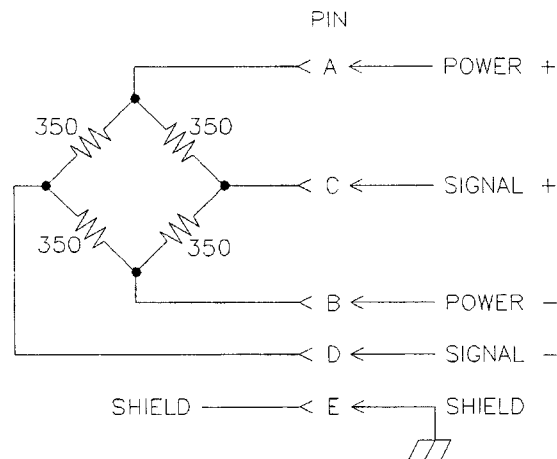

Figure 4. - Sensor Bridge Configuration

REAR PANEL: (See Figure 3)

1. ANALOG OUTPUT: Provides a DC voltage or a 4-20 MA current output, proportional to the pressure measured, to be used with chart recorders or other monitoring equipment see Analog Output Section on page 6 for more details. Shown in figure 6 is the soldered connections to the 1/4" stereo plug for output to analog input devices. Use stranded, two conductor, shielded wire for connections. Terminate the shield at the equipment end (chart recorder or other monitoring device). Do not connect the shield to this connector.

2. SENSOR INPUT: Attach a D-M-E pressure sensor to this connector. Sensor connections are shown in figure 4.

3. MACHINE INTERFACE: This is the user interface connector. The user provides a dry relay contact closure on pins 1 and 2 indicating to the control that the process has begun. As an output for closed loop control, when the measured pressure exceeds the setpoint pressure, a relay will energize

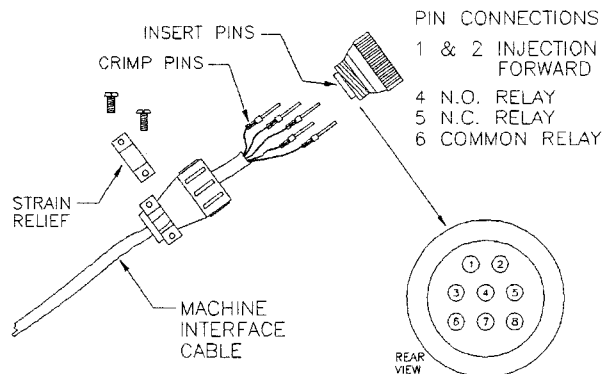

Figure 5. - Machine Interface Connector

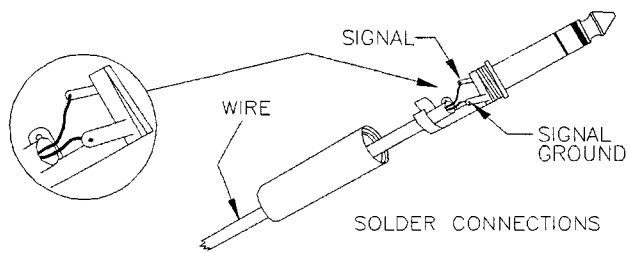

Figure 6. - Analog Output Plug

indicating that the process is complete, thus a pair of relay contacts have been made available for user purposes: a normally-open set of contacts, pins 4 and 6, and a normally-closed set of contacts, pins 5 and 6. See figure 5 for assembly details of the machine interface connector. Use stranded wire for connections, with maximum wire insulation diameter of 0.068".

4. POWER INPUT: To operate this unit with 120 Volts AC order the IPC-01-01 and apply 120 Volts AC to this connection. To operate with 240 Volts AC order the IPC-01-02 and apply 240 Volts AC to this connection. SEE IMPORTANT WARNING.

NOTE: THE 120/240 VAC OPTION IS JUMPER SELECTED ON THE PRINTED CIRCUIT BOARD. SEE COMPONENT LAYOUT FOR DETAILS. **WARNING: THIS UNIT WILL BE DAMAGED AND POSSIBLY CAUSE INJURY TO PERSONNEL IF THE JUMPER SELECTION FOR THE APPLIED VOLTAGE IS SELECTED INCORRECTLY.**

ZERO & CALIBRATION PROCEDURE: (Mold or Hydraulic Pressure)

1. Turn power on and let unit warm up for 30 minutes with a pressure or hydraulic sensor attached. Use SS-405C or BS-412C sensor for pin sizes 1/16" through 3/16" diameters. Use SS-406C or BS-413C sensor for pin sizes 3/16" through 1/2" diameters. Use HPS-420 for 0 to 2000 PSI hydraulic pressure.
2. Place the Pin Size switch in the CAL position.
3. Place the Mode switch in the Pressure Track position.
4. With NO pressure applied, using a small blade screwdriver, adjust the ZERO potentiometer (screw) located on the front panel to read 000 on the digital display.
5. Press the CAL button and adjust the CAL potentiometer (screw) located on the front panel so that the digital display indicates the calibration value located on the sensor tag. This is typically 8900 PSI, the display will show 890 with a multiplier of X10 = 8900. This value may be different based on the sensor you are using. If using metric units convert Bars to PSI to achieve the desired calibration value. (390 Bars = 8900 PSI.)
6. Repeat steps 4 and 5 above until the display reads the values consistently.
7. Set the Pin Size switch to the correct pin size you are using. If a hydraulic sensor is used, place the Pin Size switch in the HYD position. The X10 multiplier for the display is not used when using a hydraulic sensor, therefore, the display will read directly from zero to 1,999 PSI.

Unit is now calibrated.

ADDITIONAL FACTORY CALIBRATIONS: Next two steps are internal calibrations and are to be conducted periodically at the factory. **CAUTION: HIGH VOLTAGE ELECTRICAL SHOCK HAZARD. ONLY QUALIFIED INDIVIDUALS SHOULD ATTEMPT TO CONDUCT THE FOLLOWING STEPS.**

Open the unit by removing the 4 side panel screws and removing the top cover exposing the printed circuit board

8. Rotate the mode switch to Peak Pressure and Adjust potentiometer #R43, located on the printed circuit board, so that the display reads 000.

9. With a voltmeter, measure the output of the unit at the Analog Output jack, located on the rear panel of the unit, from signal to ground, and adjust potentiometer #R16 until the reading is zero volts dc on the voltmeter.

10. Unit is now calibrated.

INSTALLATION OF MOLD PRESSURE SENSOR:

1. Sensor should slide in freely with hand force.
2. Sensor should be fully in and behind the ejector pin.
3. Controller should still read 000. Re-Zero if necessary.
4. Controller should read pressure when ejector pin is pressed.
5. Tie sensor cable out of the way to prevent damage.
6. If a slide sensor is installed in such a manner that it may slip out of the mold while running, a retaining device should be used.

INSTALLATION OF HYDRAULIC PRESSURE SENSOR:

1. Install HPS-420 into the hydraulic circuit between the injection cylinder and the injection flow control valve.
2. Controller should still read 000. Re-Zero if necessary.
3. Controller should read pressure when screw injects.

CONTROL OPERATING INSTRUCTIONS:

1. Connect controller to power and make necessary connections to the injection molding machine.
2. Zero and calibrate sensor per previous instructions.
3. Mold acceptable parts with MONITOR / CONTROL switch in MONITOR mode.
4. Observe and record the peak pressure reading on the controller (place display selector in PEAK PRESSURE position.)
5. Set the SETPOINT slightly below the peak pressure reading seen on the display (Requires placing the display selector in the SETPOINT position.)
6. Place the MONITOR / CONTROL switch in the CONTROL position.
7. **WARNING:** Watch for incompletely filled or flashed parts.

8. Return display selector to PEAK PRESSURE.

9. Over the next several shots, adjust the SETPOINT knob until the desired peak pressure is obtained.

NOTE: It will be necessary to add time to the machine's first stage (Boost) timer, and/or, it will be necessary to increase the first stage (Boost) position limit switch in order for the IPC to take control of the molding process.

OPTIMIZING:

Material savings will be achieved by lowering the SETPOINT until short shots are obtained. Increase the SETPOINT until fully filled parts are obtained on a repeatable basis.

Production rate will be enhanced by increasing first stage pressure and flow rates on the machine. It may be necessary to lower the IPC SETPOINT to obtain the previously recorded (or desired) peak pressure while increasing the machine settings.

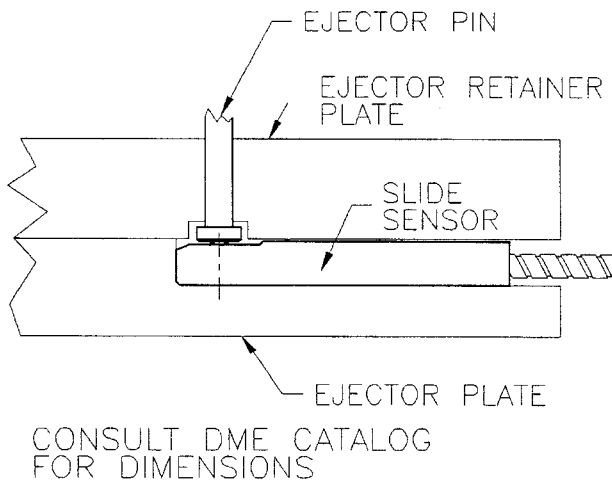

Figure 7. - Typical Slide Sensor Installation

ANALOG OUTPUT SELECT:

Figure 8 shows slide switch SW6 which when in the volts* position will output the voltage selected on SW5 to the analog output jack located on the rear panel. When SW6 is put in the 4-20MA position the output jack will then produce a signal that is proportional to the applied pressure where a 4 MA current represents 0 PSI and 20 MA current represents full scale PSI. If SW6 is placed in the voltage select mode, then SW5 must be set to one of the following positions to output the desired voltage output scaling.

Position 1 (1) ON all others OFF = 0 - 1 volt output.

Position 2 (2) ON all others OFF = 0 - 2 volt output.

Position 3 (5) ON all others OFF = 0 - 5 volt output. **

Position 4 (10) ON all others OFF = 0 - 10 volt output.

* Set for voltage output at the factory.

** Set for 0-5 V at the factory.

RETURN POLICY:

The D-M-E® IPC units are warranted for 1 year parts and labor, excluding fuses.

Contact D-M-E Customer Service for return authorization for repairs or warranties. Replacement parts are also available through the Customer Service Department.

D-M-E CUSTOMER SERVICE

In U.S., West Coast: (213) 263-9261
Elsewhere in U.S.: (800) 626-6653
In Canada: (416) 677-6370

SERVICE CENTER U.S.A

D-M-E WORLD HEADQUARTERS
29111 STEPHENSON HIGHWAY
MADISON HEIGHTS, MICHIGAN 48071
TELEFAX: (810) 398-6174

REPLACEMENT PARTS LIST:

To meet warranty requirements, use only DME® parts.

S1, Power Rocker Switch, 16 Amp, 250 VAC	RPM0008
F1, F2, Fuse, 1 Amp, 250 Volt	ABC1
Relay, ST1E-DC24V, Aromat	RPM0040
Input Amplifier, INA114AP, Burr Brown	RPM0041
Machine Interface Connector Kit with Pins	RPM0042
Power Transformer, LP30-400, Signal	RPM0043

PRESSURE SENSORS AND ACCESSORIES:

BS-412C 500 LB Button Sensor 1/16" - 3/16" dia. pins. (Requires the BSC-10 Button Sensor Extension Cable.)	
BS-413C 2000 LB Button Sensor 3/16" - 1/2" dia. pins. (Requires the BSC-10 Button Sensor Extension Cable.)	
SS-405C 500 LB Slide Sensor 1/16" - 3/16" dia. pins. (Integral 10 foot cable.)	
SS-406C 2000 LB Slide Sensor 3/16" - 1/2" dia. pins. (Integral 10 foot cable.)	
HPS-420C Hydraulic Pressure Sensor, 0-3000 PSI. (Integral 10 foot cable.)	

EXTENSION CABLES

BSC-10 Button Sensor Extension Cable, 10 foot. (One required for each Button Sensor.)	
SSC-10 Slide Sensor Extension Cable, 10 foot. (Extends sensor cables by 10 feet.)	
SI-900 Sensor Interface Box, 15 foot cable, JIC enclosure at sensor end of cable. Extends sensor cables by 15 feet. JIC box provides rigid mounting to mold or machine.	
RC-10 High level signal output cable. 1/4" male to 1/4" male stereo phone jack with 10 foot cable. Allows for connection of IPC high level output to other equipment.	

SLIDE SENSOR ACCESSORIES

SSE-418 Slide Sensor Extension. Aids in removing and installing Slide Sensor from mold. Multiple units may be connected end-to-end for longer lengths.	
SSB-419 Slide Sensor Blank. Fills empty slot in mold when sensor is not installed.	

D-M-E® is a registered trademark of D-M-E Company.

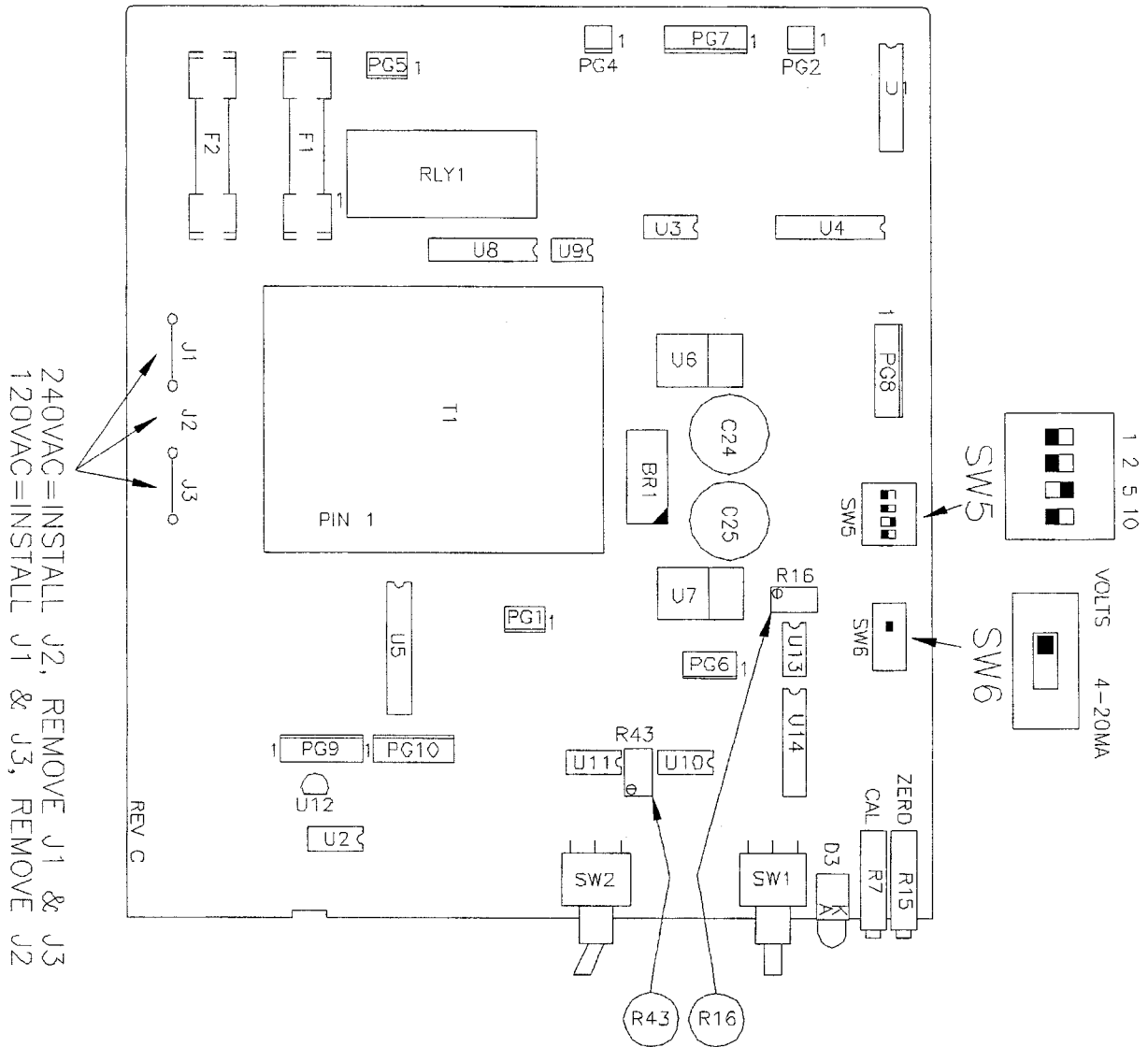

Figure 8. - IPC, Printed Circuit Board, Component Layout