

Granulators



DRG Series Granulators

Standard Features

- Infeed hopper specifically designed for beside-the-press manual or robot-fed loading
- No sizing screen (screenless)
- Clear-view hopper design allows operator to see the material being processed
- Automatic reversing system is standard for reversing the rotation of the rotor to easily clear any material obstruction
- Integrated metal detection is internal to the machine to help prevent metal contamination
- Equipped with an emergency stop button
- Quiet operation (70-80 dB)
- Energy saving low horsepower
- Uniform granule size
- Heavy-duty construction
- No special tools required to open the granulator
- D2 crusher blades and cutting wheel
- Multiple safety interlocks prevent injury by restricting access to the granulator while operating
- Compact and mobile, caster mounted base saves valuable floor space and provides greater versatility



Dimensions and Features

Part No	Cutting Chamber Opening	Motor HP	Crusher Blades	Cutter Wheel Segments	Throughput lbs/hr	A	B	C	D
DRG79	8.7" x 6.9" (223 mm x 265 mm)	3	1	2	Up to 15lbs/hr	13.38" (340 mm)	13.58" (345 mm)	50.19" (1275 mm)	46.53" (1,182 mm)
DRG910	9" x 10.4" (228 mm x 265 mm)	3	2	3	Up to 20lbs/hr	13.5" (342 mm)	17.6" (448 mm)	52.1" (1,325 mm)	50.2" (1,276 mm)
DRG914	9" x 14.1" (228 mm x 359 mm)	3	3	4	Up to 30lbs/hr	13.45" (341 mm)	19.75" (502 mm)	58" (1,473 mm)	54" (1,370 mm)
DRG917	9" x 17.8" (228 mm x 453 mm)	3	4	5	Up to 40lbs/hr	13.5" (345 mm)	27" (691 mm)	57.7" (1,466 mm)	57.6" (1,466 mm)

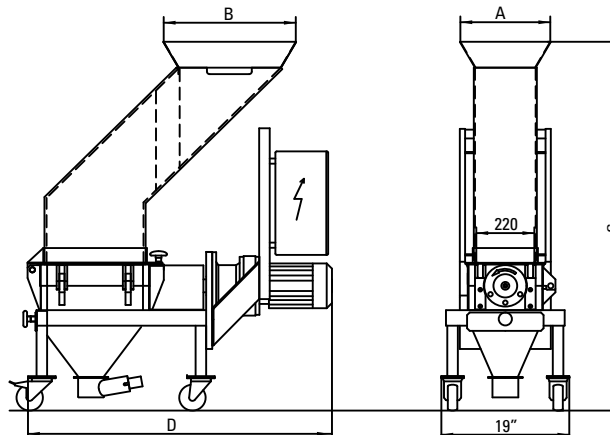

DSG Series Granulators



Standard Features

- Staggered Rotor
- Hardened cutting chamber
- Cassette Knives
- No knife starters
- D2 tool steel knives
- Allen-Bradey starters
- Safety interlocks
- Lo infeed height
- Scissor cut action knives
- Solid rotor pulley
- Rotating end disc
- Caster Mounted (Neoprene)
- Low RPM motor
- Reversible screen
- Removable flaps
- Tilt-back hopper
- Drop-down screen cradle
- Sound-proofed hopper

Part No	HP	A	B
DSG69	3 HP	6 x 9	13.75
DSG614	3 HP, 5HP	6 x 14	19.5
DSG617	3 HP, 5HP	6 x 17	22.5

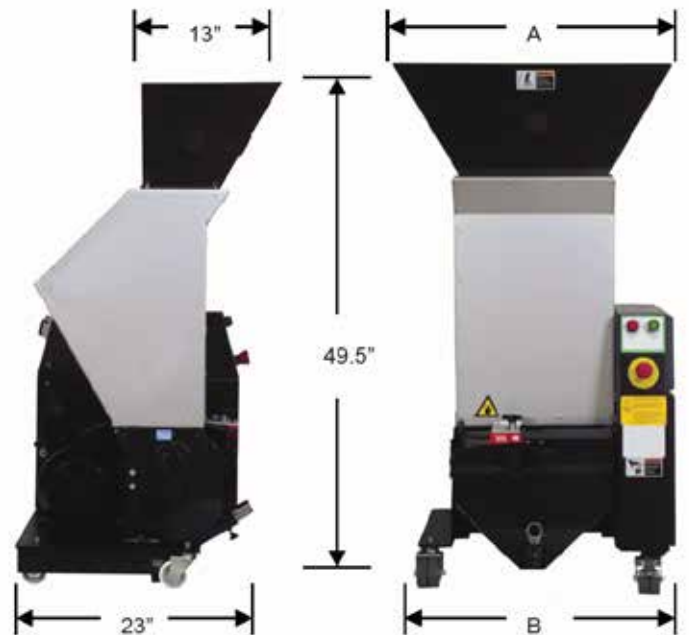

DSSG Series Granulators

Standard Features

- Choice of 6"x9", 6"x14" or 6"x17" cutting chambers
- 3 HP motor
- Staggered rotor
- Cassette knives
- No knife adjustment
- D2 tool steel knives
- Allen-Bradley starters
- Multiple safety interlocks
- Low infeed height
- Scissor cut action knives
- Solid rotor pulley
- Caster mounted
- Low RPM motor
- Reversible screen
- Removable flaps
- Tilt-back hopper
- Drop-down screen cradle



Dimensions

Part No	A	B
DSSG69	19.3"	19.7"
DSSG614	25.1"	25.2"
DSSG617	27.5"	27.95"

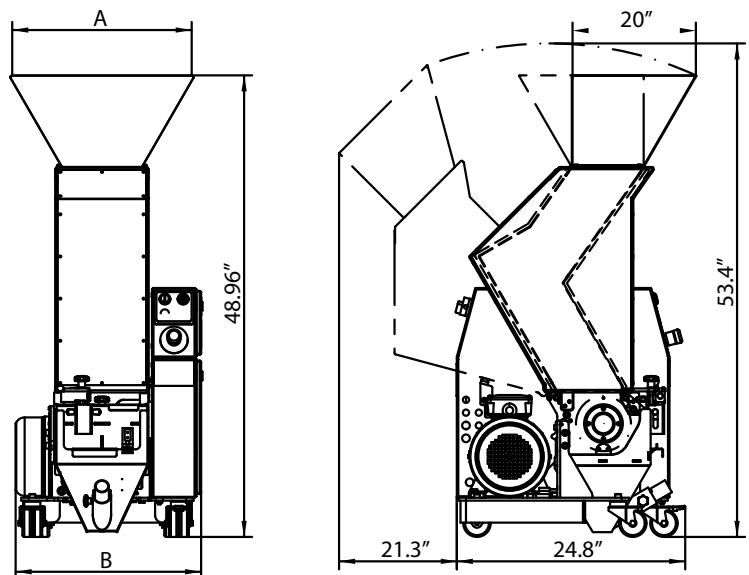

DSFG814 Granulator



Standard Features

- 8" x 14" cutting chamber
- 7.5 HP motor
- Staggered rotor
- Cassette Knives
- No knife adjustment
- D2 tool steel knives
- Allen-Bradey starters
- Safety interlocks
- Low infeed height
- Scissor cut action knives
- Solid rotor pulley
- Rotating end disc
- Caster Mounted
- Low RPM motor
- Reversible screen
- Removable flaps
- Tilt-back hopper
- Drop-down screen cradle

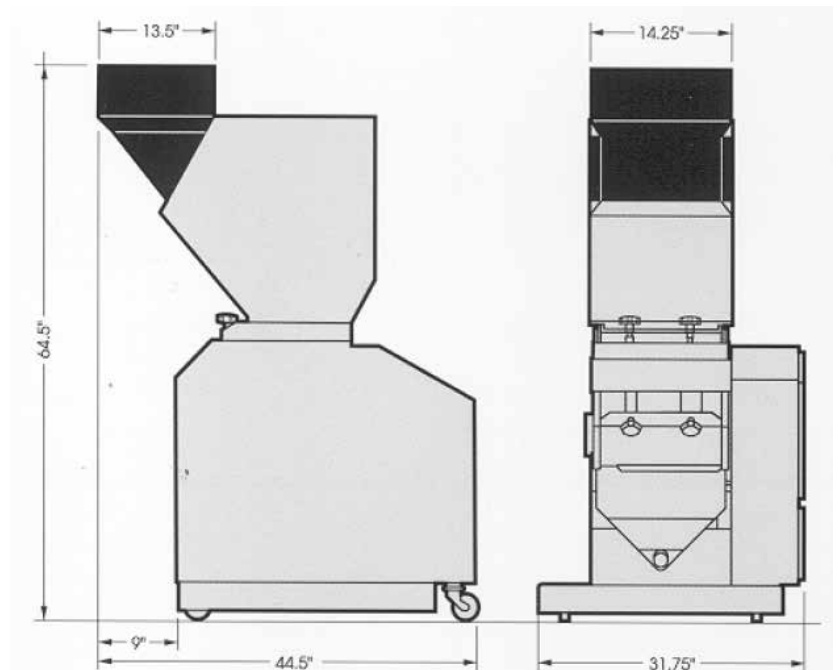

DFG Series Granulators



Standard Features

- Staggered rotor
- Cassette Knives
- No knife adjustment
- D2 tool steel knives
- Low infeed height
- Scissor cut action knives
- Flywheel type pulley
- Rotating end disc
- Low RPM motor
- Reversible screen
- Removable flaps
- Tilt-back hopper
- Drop-down screen cradle
- TEFC motor
- Redundant safety switches
- Low noise level
- Oversized sealed bearings
- Compact design - minimum floor footprint

Part No	A	B
DFG810	27"	9.5"
DFG814	32"	14.25"
DFG819	36"	19"
DFG824	40.5"	23.6"

	DFG810	DFG814	DFG819	DFG824
Rotor Diameter (in)	7.8"	7.8"	7.8"	7.8"
Cutterhouse opening (in)	8" x 9.5"	8" x 14"	8" x 19"	8" x 24"
Capacity (lbs/hr.)	0-150	0-225	0-350	0-500

