

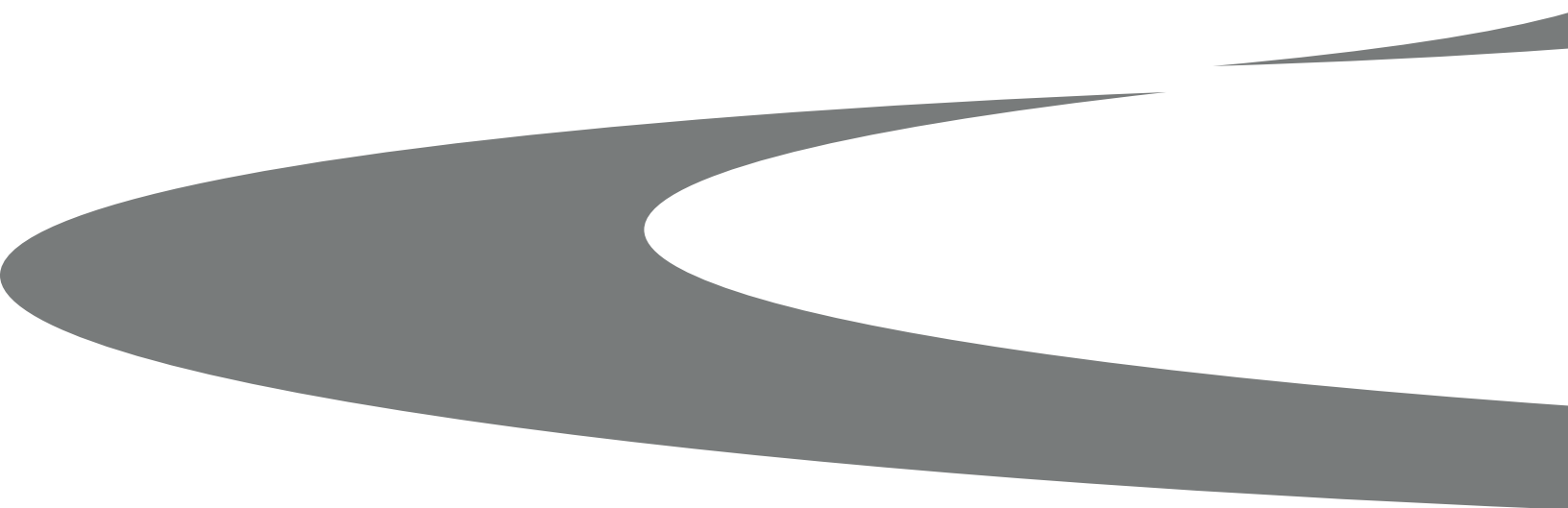

DME



MUD[®] QUICK-CHANGE SYSTEMS



INTRODUCTION

An Introduction to the MUD® Quick-Change Concept
A cost-effective approach to injection molding..... 4-8
Customer Commitment..... 9
DME Terms and Conditions of Sale..... 10
Sales and Ordering Information..... 11

U FRAME

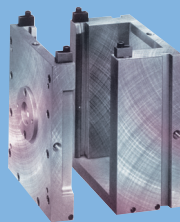

MUD® U Frame Ordering Information UF 12
 Insert Mold Ordering Information UF 12
 U Frame Features and Applications UF 13
 Companion Insert Mold Features and Applications UF 14
 Enhanced Series Mold Inserts – Solid & Laminated UF 15
 05/05 UF Companion Insert Mold (3.25 x 3.75 & 4.0 x 4.7) UF 16
 07/07 UF Companion Insert Mold (4.5 x 6.25 & 6.0 x 7.25) UF 17
 08/09 UF Companion Insert Mold (5.0 x 8.0 & 7.85 x 9.0) UF 18
 08/10 UF Companion Insert Mold (5.0 x 9.0 & 7.85 x 9.0) UF 19
 94/90 UF Companion Insert Mold (6.5 x 8.0 & 8.4 x 9.0) UF 20
 84/90 UF Companion Insert Mold (6.5 x 8.0 & 8.4 x 9.0) UF 21
 09/07 UF Companion Insert Mold (6.0 x 6.75 & 9.0 x 6.75) UF 22
 09/07 EB Companion Insert Mold (6.0 x 6.75 & 9.0 x 6.75) UF 23
 10/12 UF Companion Insert Mold (7.0 x 10.9 & 9.9 x 10.9) UF 24
 10/14 UF Companion Insert Mold (7.0 x 12.9 & 9.9 x 12.9) UF 25

10/16 UF Companion Insert Mold (7.0 x 14.9 & 9.9 x 14.9) UF 26
 11/11 UF Companion Insert Mold (8.0 x 10.0 & 11.5 x 11.0) UF 27
 12/08 UF Companion Insert Mold (8.0 x 8.0 & 11.9 x 8.0) UF 28
 12/14 UF Companion Insert Mold (8.0 x 12.9 & 11.9 x 12.9) UF 29
 12/16 UF Companion Insert Mold (8.0 x 14.9 & 11.9 x 14.9) UF 30
 12/18 UF Companion Insert Mold (8.0 x 16.9 & 11.9 x 16.9) UF 31
 12/20 UF Companion Insert Mold (8.0 x 18.9 & 11.9 x 18.9) UF 32
 13/16 UF Companion Insert Mold (9.0 x 14.9 & 12.9 x 14.9) UF 33
 13/18 UF Companion Insert Mold (9.0 x 16.9 & 12.9 x 16.9) UF 34
 13/20 UF Companion Insert Mold (9.0 x 18.9 & 12.9 x 18.9) UF 35
 13/22 UF Companion Insert Mold (9.0 x 20.9 & 12.9 x 20.9) UF 36
 14/16 UF Companion Insert Mold (10.0 x 14.9 & 13.9 x 14.9) UF 37
 14/18 UF Companion Insert Mold (10.0 x 16.9 & 13.9 x 16.9) UF 38
 14/20 UF Companion Insert Mold (10.0 x 18.9 & 13.9 x 18.9) UF 39
 14/22 UF Companion Insert Mold (10.0 x 20.9 & 13.9 x 20.9) UF 40
 16/18 UF Companion Insert Mold (11.0 x 15.9 & 15.9 x 15.9) UF 41
 16/21 UF Companion Insert Mold (11.0 x 18.9 & 15.9 x 18.9) UF 42
 16/24 UF Companion Insert Mold (11.0 x 21.9 & 15.9 x 21.9) UF 43
 16/27 UF Companion Insert Mold (11.0 x 24.9 & 15.9 x 24.9) UF 44
 18/20 UF Companion Insert Mold (12.0 x 17.9 & 17.9 x 17.9) UF 45
 18/26 UF Companion Insert Mold (12.0 x 23.9 & 17.9 x 23.9) UF 46

H FRAME

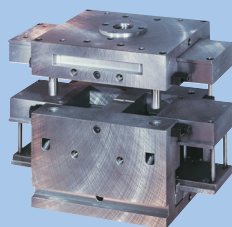

MUD® H Frame Ordering Information HF 47
 Insert Mold Ordering Information HF 47
 H Frame Features, Options and Applications HF 48
 Companion Insert Mold Features, Options and Applications HF 49
 07/07 HF Companion Insert Molds (3.25 x 3.15) HF 50
 08/09 HF Companion Insert Molds (5.0 x 3.5) HF 51
 10/12 HF Companion Insert Molds (5.0 x 5.0) HF 52
 10/18 HF Companion Insert Molds (5.0 x 8.0) HF 53
 11/14 HF Companion Insert Molds (6.0 x 6.0) HF 54
 11/18 HF Companion Insert Molds (6.0 x 8.0) HF 55
 12/11 HF Companion Insert Molds (7.0 x 4.5) HF 56
 12/13 HF Companion Insert Molds (7.0 x 5.5) HF 57
 12/15 HF Companion Insert Molds (7.0 x 6.5) HF 58
 12/19 HF Companion Insert Molds (7.0 x 8.5) HF 59

13/13 HF Companion Insert Molds (8.0 x 5.5) HF 60
 13/15 HF Companion Insert Molds (8.0 x 6.5) HF 61
 13/17 HF Companion Insert Molds (8.0 x 7.5) HF 62
 13/19 HF Companion Insert Molds (8.0 x 8.5) HF 63
 13/23 HF Companion Insert Molds (8.0 x 10.5) HF 64
 14/15 HF Companion Insert Molds (9.0 x 6.5) HF 65
 14/17 HF Companion Insert Molds (9.0 x 7.5) HF 66
 14/19 HF Companion Insert Molds (9.0 x 8.5) HF 67
 14/21 HF Companion Insert Molds (9.0 x 9.5) HF 68
 14/25 HF Companion Insert Molds (9.0 x 11.5) HF 69
 15/15 HF Companion Insert Molds (10.0 x 6.5) HF 70
 15/17 HF Companion Insert Molds (10.0 x 7.5) HF 71
 15/19 HF Companion Insert Molds (10.0 x 8.5) HF 72
 15/21 HF Companion Insert Molds (10.0 x 9.5) HF 73
 15/25 HF Companion Insert Molds (10.0 x 11.5) HF 74
 17/19 HF Companion Insert Molds (11.0 x 8.5) HF 75
 17/26 HF Companion Insert Molds (11.0 x 12.0) HF 76
 18/22 HF Companion Insert Molds (12.0 x 10.0) HF 77
 18/26 HF Companion Insert Molds (12.0 x 12.0) HF 78
 18/30 HF Companion Insert Molds (12.0 x 14.0) HF 79
 "E" Frame Companion Insert Molds EF 80



DOUBLE H FRAME

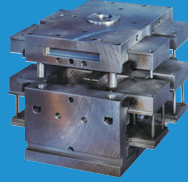

MUD® Double H Frame Ordering Information	DF 81
Insert Mold Ordering Information	DF 81
Double H Frame Features, Options & Applications	DF 82

ADAPTER FRAME

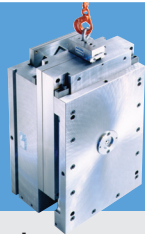

MUD® Adapter Frame Ordering Information	AF 91
System Accessories	AF 92
Ear Plate Installation Instructions	AF 93
Adapter Frame Installation Instructions	AF 94-95
12/18 AF Companion Ear Plates (AEP 011 & AEP 022)	AF 96
14/20 AF Companion Ear Plates (AEP 011 & AEP 022)	AF 97
16/21 AF Companion Ear Plates (AEP 011 & AEP 022)	AF 98
18/26 AF Companion Ear Plates (AEP 011 & AEP 022)	AF 99

COMPONENTS

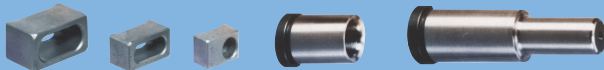

MUD® Components	C 116
Frames & Insert Mold Tapered Leads	C 117
Leader Pins, Bushings and Accessories	C 118-119
Sprue Bushings	C 120-121
Top Locating Rings	C 122-123
Bottom Locating Rings	C 124

OPTIONS

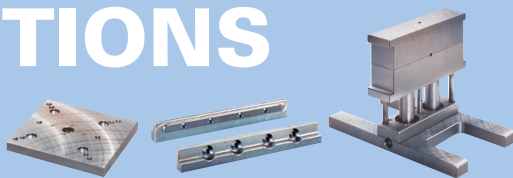

MUD® Options Mold and Die Steels	OP 134
MUD® Options Features and Applications	OP 135
Sleeve Ejector Plate Assemblies	OP 136
Interlocking Ejector Plate Rails	OP 137
Interlocking Ejector Plates	OP 138
U Frames with Master Ejector Systems	OP 139
Removable Center Sections	OP 140
Removable Center Bar Assemblies	OP 141
Center Bar Insert Molds	OP 142-143

Companion Insert Mold Features, Options & Applications	DF 83
12/08 DF Companion Insert Molds (3.25 x 3.15).....	DF 84
16/09 DF Companion Insert Molds (5.0 x 3.5).....	DF 85
16/12 DF Companion Insert Molds (5.0 x 5.0).....	DF 86
16/18 DF Companion Insert Molds (5.0 x 8.0).....	DF 87
20/14 DF Companion Insert Molds (6.0 x 6.0).....	DF 88
22/19 DF Companion Insert Molds (7.0 x 8.5).....	DF 89
24/23 DF Companion Insert Molds (8.0 x 10.5).....	DF 90

22/30 AF Companion Ear Plates (AEP 011 & AEP 022)	AF 100
24/36 AF Companion Ear Plates (AEP 011 & AEP 022)	AF 101
Quick Coupler Knockout Rod Assembly	AF 102
Balancing Lift Bars and Buttons	AF 103
MUD® Mold Change Cart	AF 104
Adapter Systems with Instant-Connect™ Waterlines	AF 105
Waterline System Ordering Information	AF 105
Features and Applications	AF 106-107
4-Coupler Instant-Connect Waterline System	AF 108-109
6-Coupler Instant-Connect Waterline System	AF 110-111
10-Coupler Instant-Connect Waterline System	AF 112-113
Mold Base Adapter Back Section Manifolds	AF 114
Ear Plate Machining Specifications	AF 114
The MUD® Waterline Purge System™	AF 115

Mold Clamps	C 125
Hoist Rings – INCH: Installation and Ordering Information	C 126
Ear Plates for T-Style Insert Molds	C 127
Standard Ejector Plate Sets	C 128
Guide Posts	C 129
Guide Bushings	C 130
Insert Mold Pillar Posts	C 131
Hardened Runner Pads	C 131
Shoulder Screws, Sprue Puller Plugs, Rest Buttons	C 132
Insert Mold Holding Clamps	C 133
Mold Base Adapter Frame Rollers	C 133

Stripper Plate and Three-Plate Insert Molds	OP 143
UF Extended Clamp Bar Sets	OP 144
UF Spacer Plate Sets	OP 144
UF Adapter Assemblies	OP 145
UF Adapter Plates	OP 146
UF Bolster Plates	OP 147
Special Adapter Plates	OP 148
High Temperature Insulator Sheets	OP 149
Additional Ear Slots	OP 149
Insert Mold Loading Rails	OP 150
Mold Tooling Protection	OP 151
Two-Color, Two-Material Molding	OP 152
Standard Heat Pipes	OP 153
Hot Runner-Infused Quick-Change Systems	OP 154



The MUD[®] Quick-Change Concept

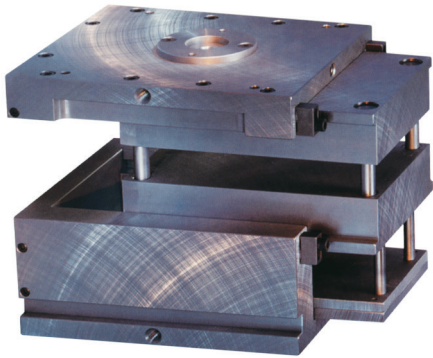

Quick-Change U Frame

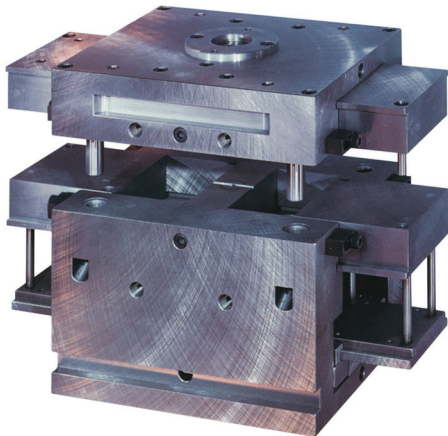

Quick-Change H Frame

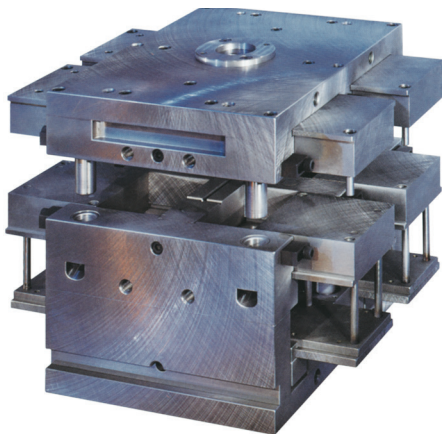

Quick-Change Double H Frame

A cost-effective approach to injection molding

This Master Unit Die Quick-Change Concept was developed to meet the parallel challenges of increasing productivity and decreasing costs. MUD[®] Quick-Change Systems are more frequently becoming a part of the operational strategies for many companies who employ lean manufacturing programs because MUD[®] systems are proven to deliver increased uptime and reduced costs.

The tooling approach to injection molding presented in this catalog offers mold makers and plastics manufacturers a number of competitive advantages. These include lower tooling costs and faster production changeovers. The remarkable flexibility this approach offers makes it ideal for just-in-time scheduling.

Faster production changeovers and lower tooling costs

The Master Unit Die Quick-Change system approach is based on an unlimited number of companion insert molds easily interchanged within a single MUD[®] Quick-Change frame. The frame remains in the molding machine during these mold changeovers.

Most changeovers take less than five minutes, require no special equipment and can be made by one person. Simply loosen four clamps, disconnect any heating or cooling lines and slide the insert mold from the Quick-Change frame. Then slide in the replacement, reconnect the lines and reclamp. The new insert mold is now ready for production.

This approach to tooling reduces downtime as much as 75 percent. Related labor costs are reduced even more since the need for a second person to assist in the mold change is also eliminated.

The initial cost for new tooling is also reduced as much as 66 percent. This is because only the companion insert mold is replaced to produce a new part. It is not necessary to replace an entire standard mold base. Associated labor costs are lowered because insert molds are much easier to handle than larger, heavier standard mold bases.

This combination of reduced production downtime, reduced labor cost and reduced tooling expense can result in a significant improvement in profit margins.

Reduces downtime by as much as 75 percent.
Reduces initial cost by as much as 66 percent.



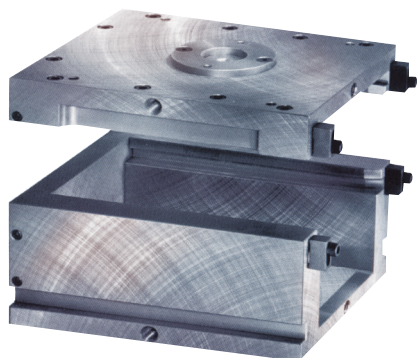

Quick-Change U Frame

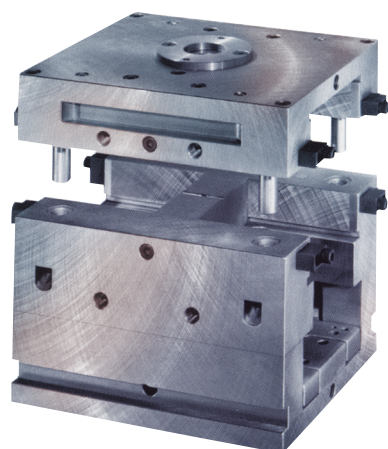

Quick-Change H Frame

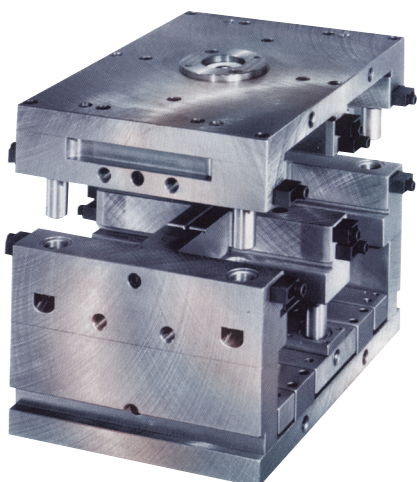

Quick-Change Double H Frame

Quick-Change frames and companion insert molds

Three Quick-Change frame series

The MUD® Quick-Change Concept is available in three frame series and in sizes for the smallest air-operated machines to models for 500-ton machines.

The MUD® **U frame** series offers the most design flexibility and accepts both standard and T-style companion insert molds. **H frame** and **Double H frame** models offer simultaneous molding with two and four standard style companion insert molds. The benefits of both Quick-Change tooling and hot runner molding can be combined with the addition of a manifold to MUD® H and Double H frame models.

All Quick-Change frames are precision made to exacting tolerances and are easily matched to the specifications of individual machines. Each is engineered for extra strength and rigidity and is designed for maximum molding flexibility.

Two companion insert mold series

Master Unit Die companion insert molds for Quick-Change frames offer designers and mold makers exceptional application flexibility. Each is available in a variety of steels and is interchangeable within matching frames. The insert mold includes the cavity and core plates with leader pins and bushings installed and the ejector plates. Since this insert assembly is all that's needed to produce new parts, tooling costs are reduced significantly.

Standard Style Insert Molds offer maximum economy and are available in solid or laminated construction including three- and four-plate designs. Options and features include stripper plate, sleeve ejection and other special applications designed to meet virtually all injection molding needs. See U frame, H frame and Double H frame sections for details.

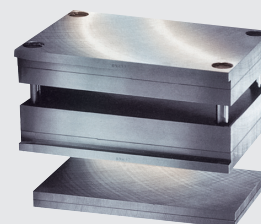

Standard Laminated Insert Mold

T-Style Insert Molds offer the maximum projected mold area and are available in laminated construction including three- and four-plate designs. Smaller models are also available in solid construction. Options and features include stripper plates, sleeve ejection and other special applications. See U frame section for details.

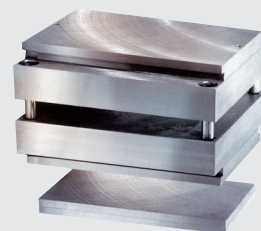

T-Style Laminated Insert Mold

Advantages of the MUD® Concept

Maximize your
production volume
and minimize your
downtime with our
Quick-Change
insert molds.

Quick-Change tooling offers you advantages at every step in the manufacturing process from tooling lead time and cost to production and inventory control.

Quicker Delivery

New tooling orders require less lead time because only a companion insert mold is required, not an entire standard mold base. This results in less time required for machining. Also, standard insert molds are usually shipped immediately from stock, seldom require more than seven to ten working days.

Lower Tooling Costs

Since only an insert mold is needed for new, standby or replacement tooling, the cost is less for both material and fabrication. Costs are reduced as much as 66 percent. Another cost reduction feature is the use of spacer bars in larger frames. These permit the use of smaller, less expensive insert molds.

Faster Initial Mold Setup

The MUD® Quick-Change frame stays in the molding machine. Initial setup is simply a matter of sliding the insert mold in, then clamping it and connecting the heating or cooling lines.

Maximum High Volume Production

H frames and Double H frames offer special advantages for high volume production. Multiple insert molds permit doubling (H frame) or quadrupling (Double H frame) quantities each cycle. Production is virtually uninterrupted during maintenance or repair by using quickly installed backup insert molds.

Quicker Production Changeovers

Just loosen four clamps, disconnect heating or cooling lines and slide the insert mold from the Quick-Change frame. Then slide in the replacement, reclamp, and reconnect the lines. Most changeovers require less than five minutes.

Minimum Purging

Because MUD® insert molds can be interchanged in moments, the machine cylinder is not likely to require purging due to overheating. Both raw material and production time are saved.

Easier Maintenance and Repair

MUD® insert molds are faster to remove and reinstall than standard mold bases. They are also much lighter and smaller. This means scheduled preventative maintenance is much easier to perform. There is also less downtime if the insert mold is ever removed for modification or repair. If the insert mold must be out for a long period, a replacement can be easily installed and the machine back in production within five minutes.

Convenient Storage

Since the MUD® Quick-Change frame stays in the machine, only the companion insert mold needs to be stored. Their lighter weight and smaller size means easier handling. Most models can be stored on bookcase-type shelves.



Production Flexibility

MUD® Quick-Change H and Double H frames are designed for simultaneous molding with two or more companion insert molds. These insert molds can be interchanged independently. When single insert mold production is scheduled, blank insert molds are easily installed. Duplicate insert molds can be installed when greater volume of a part is required.

Design Versatility

MUD® companion insert molds are available in T-style and standard style and in solid and laminated construction. Design latitude is unlimited. Insert molds can be engineered for parts requiring stripper plates, sleeve ejection, single or double cam action, hydraulic, mechanical or pneumatic cylinders — virtually any feature desired including three- and four-plate designs.

Applications

Prototypes and Samples

Faster setup and startup means the Master Unit Die Concept is ideal for this type of application. Even more important, engineering changes involve only the companion insert mold, not an entire standard mold base. This keeps sample and experimental tooling time and cost to an absolute minimum.

Aluminum Insert Molds

The thermal conductivity of available aluminum insert molds approaches four times that of steel for even faster cycling times. These lightweight insert molds are also easy to handle and can be machined at high speeds. See pages UF 18, UF 20 and UF 21.

Short Production Runs

MUD® insert molds offer unparalleled advantages when a variety of parts must be produced in a short time period, a major plus for just-in-time scheduling. Literally hours of production time are gained by these fast changeovers, often eliminating the need for overtime. The lower cost of these insert molds also makes duplicate tooling attractive insurance for meeting critical deadlines.

High Volume Production

The simultaneous molding of parts in multi-section frames is one of the major Quick-Change advantages in increasing productivity. So is the lower cost of backup insert molds. Another advantage is the ease and speed of installing insert molds since this almost eliminates production downtime. And since all molds require some maintenance, this time gained in removing and installing insert molds has added significance. MUD® Quick-Change frames and companion insert molds are also constructed with the precision, the strength and the reliability to meet the demands of high volume production.

**Customized
and versatile,
MUD® insert
molds meet
your specific
production
needs.**

The MUD[®] Quick-Change Concept Standard Mold Bases

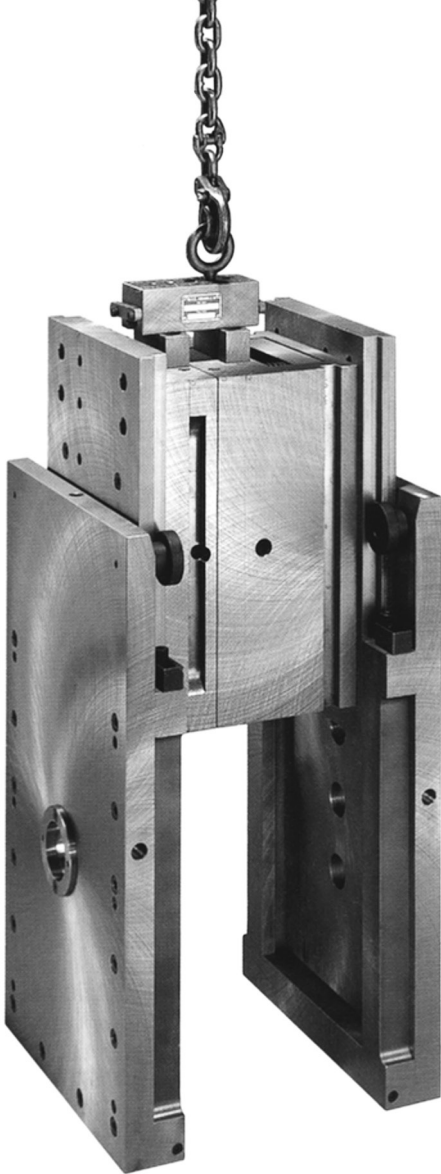

MUD[®] Adapter Frame System permits production changeovers in less than ten minutes

Standard mold bases can now be interchanged in less than ten minutes with MUD[®]'s Quick-Change adapter system. It's an approach that works with any standard mold base in any molding machine up to 500-ton capacity. It's also the most economical Quick-Change available.

The system is based on a Master Unit Die adapter frame that remains in the molding machine during production changeovers. The frame is installed without modifying the machine. Standard mold bases equipped with companion ear plates are interchanged within this adapter frame.

Just one adapter frame accommodates an unlimited number of standard mold bases. These frames are easily transferred to other machines since no other special mounting hardware is required. The system is based on the unique slide and clamp approach to mold changeovers developed by Master Unit Die. Standard mold bases equipped with MUD[®] ear plate sets simply slide in and out of the Quick-Change adapter frame. See Adapter Frames section.

Adapter Frame System Options

MUD[®] Balancing Lift Bar

These slide and lock bars allow standard mold bases to be easily lowered in and raised out of the molding machine. See page AF 103.

Quick Coupler Locking KO Rod System

This optional knockout assembly permits locking the mold ejector system to the machine's hydraulic KO system with a simple push and turn action. See page AF 102.

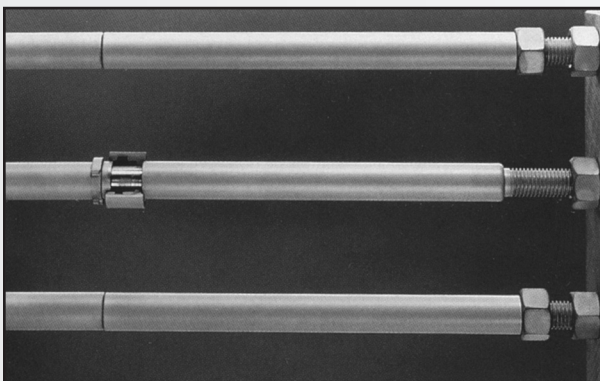

MUD[®] Balancing Lift Bars

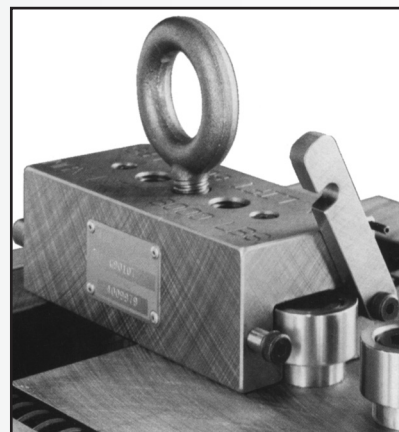

Quick Coupler Locking KO Rod Systems
U.S. PATENT #5,033,784



Customer Commitment

Applications Engineering

When you contact DME with a new application for a hot runner system, many systems go into action. DME has its own design and applications engineering group consisting of professional engineers and experienced designers. After you have given us the information necessary for proper application design and analysis, the DME applications engineering team goes to work diligently analyzing, designing and manufacturing a hot runner system that will best suit your needs and requirements.

Technical Service

DME is proud to say that it is an industry model for technical service coverage and response. The DME technical service department covers the entire United States, Canada and Mexico with additional service representatives in Europe, Asia and throughout the world. Because DME knows you need assistance starting, operating, and maintaining hot runner systems it has made a great effort to strategically staff a Technical Service Department that is responsible for the success of DME's molding systems.

Field Sales and Customer Service

When you need a knowledgeable person to help you order parts and components, DME has you covered. Our direct field sales force puts a local sales representative in your area. One who understands your business and can offer valuable assistance in helping you select the molding system best suited to your application and your budget. In addition, DME provides a customer service department that has been extensively trained on all of DME's products and systems, making it easier for you to order and have your questions answered. We can provide you price and delivery information on all DME items quickly and accurately.

To take advantage of any or all of these services, or if you have any questions, problems, or ideas please call DME at:

- 800-626-6653 (U.S.)
- 800-387-6600 (Canada)
- 52-442-713-5666 (Mexico)

Part prints or system design prints may be sent in the following ways:

- app_eng@dme.net
- 888-808-4363 (U.S.) fax
- 800-461-9965 (Canada) fax
- ventas@dme.net (Mexico)

DME offers a wide range of services from component selection to on-site system installation. Our ever-growing list of services include the ability to:

- Analyze the best system to fit your needs
- Assist in system design
- Perform computerized system analysis and resin qualification before any metal is cut
- Marry your system to the mold base, plates and components required
- Provide quotations for and perform all of the special machining required
- Assemble and wire the system
- Check mechanical fit of all components and perform electrical load testing
- Assist with system start-up and maintenance

All of which gives you ... more time to concentrate on cavities and cores!



Terms and Conditions of Sale DME

DME COMPANY LLC ("SELLER")

1. **ACCEPTANCE OF TERMS:** Seller's offer is expressly conditioned upon Buyer's acceptance of these Terms and Conditions, and Seller expressly objects to any additional or different terms proposed by Buyer. Any subsequent purchase order issued by Buyer shall constitute Buyer's agreement to these Terms and Conditions. Any contrary terms and conditions contained in any purchase order, facility entry form, or other instrument issued by the Buyer are expressly rejected and shall not apply to this transaction. Unless otherwise specified in the quotation, Seller's quotation shall expire 30 days from its date and may be modified or withdrawn by Seller before receipt of Buyer's conforming purchase order.

2. **PAYMENT TERMS:** Payment is due in accordance with any applicable progress, advance or other agreed upon payment schedule, or, if no such schedule has been agreed to, no later than 30 days from the date of invoice. Buyer shall pay a late payment charge computed at the lower of 1.5% per month on any overdue balance, or the maximum rate permitted by law. No cash discount is provided. If at any time Seller reasonably determines that Buyer's financial condition or payment history does not justify continuation of Seller's performance, Seller shall be entitled to require full or partial payment in advance or otherwise restructure payments, request additional forms of payment security, suspend its performance or terminate the order.

3. DELIVERY

3.1 In the United States, products are sold FCA Incoterms 2020 point of origin; for export sales, terms are FCA Incoterms port of export. Unless otherwise agreed in writing, title and risk of loss shall pass at the time of shipment. Buyer is responsible for all taxes, duties, fees, or other governmental charges related to its purchase of goods, with the sole exception of taxes on Seller's income. Unless otherwise agreed, Buyer shall pay all packing and delivery costs.

3.2 Seller's quoted lead times and targeted delivery dates are good faith estimates and are not binding on Seller. Buyer's acceptance of delivery of Seller's products from the carrier shall constitute a waiver of any claim for delay. If Seller notifies Buyer that the products are ready for shipment and Buyer delays delivery, then Seller may charge Buyer a storage fee equal to 1.5% of the contract price per month for each month of delay. Such storage fees are in addition to any other remedies Seller may have.

3.3 Buyer shall have a reasonable opportunity to inspect any products prior to shipment. Products shall be deemed to be accepted upon the earlier of: (i) inspection at Seller's plant (provided that no reasonable objection is then raised by Buyer), or (ii) if no inspection is requested, then at shipment. If an objection is made during inspection, then Products shall be deemed accepted upon resolution of the objection by Seller.

4. WARRANTY:

4.1 Seller's express product warranty be as stated in DME's order specification documentation and shall run from the date of shipment (the "Warranty Period"). During the Warranty Period, Seller warrants that the products and services sold hereunder will be free from material defects in material, workmanship and title (the "Warranty").

4.2 If, during the Warranty Period, Seller reasonably determines that the products do not meet the Warranty, then Seller shall, at its option, repair or replace the defective product or component thereof, reperform any defective services at Seller's expense, or refund or credit to Buyer its purchase price for the defective products or services.

4.3 The Warranty will be void and will not apply: (i) when Buyer fails to promptly notify Seller of any alleged defect, (ii) when Buyer fails to properly install, maintain, or operate the products, (iii) to any product or parts thereof with a useful life, under normal operating conditions, inherently shorter than 1 month, or (iv) to products which were not made by Seller or any of Seller's affiliates, provided that in such cases Seller shall use reasonable efforts to pass on to Buyer the manufacturer's warranty.

4.4 If Seller provides any parts or services to repair a product that is not under Warranty, then such parts and services will be billed to Buyer at Seller's prevailing rates for time and materials.

4.5 The Warranty set out above is the sole and exclusive warranty provided by Seller for its products and is in lieu of, and Seller expressly disclaims, all other warranties, express or implied, oral, written or statutory. THERE ARE NO WARRANTIES OF MERCHANTABILITY OR FITNESS FOR PURPOSE FOR SELLER'S PRODUCTS.

5. LIMITATION OF LIABILITIES:

5.1 Seller's total liability to Buyer arising out of or resulting from this Contract or related in any way to Seller's products or parts thereof shall not exceed the contract price for such products.

5.2 Seller shall not be liable for loss of profit or revenues, loss of use of products,

interruption of business, downtime costs, increased operating costs, or any special, consequential, incidental indirect or punitive damages, whether incurred by Buyer or Buyer's customers.

5.3 Because the conditions of actual production in each end user's plant vary considerably, Buyer assumes all risk for the results obtained by use of Seller's products in the practice of any process, whether in terms of operating costs, general effectiveness, success or failure, and regardless of any oral or written statements made by Seller related to the use of its products.

6. **SECURITY INTEREST.** Buyer agrees that the Seller shall have and retain a purchase money security interest in the Products securing the payment of all sums becoming due hereunder. Such security interest shall attach, upon completion of manufacture, to the Products and to any parts or accessories attached to the Products and to the proceeds of any sale thereof. Buyer represents that the Products are being acquired for use in its business and that such Products will not, without prior written consent of the Seller, be sold or removed from the Buyer's place of business to which delivery is made. Buyer agrees upon Seller's request to execute any financing statements or other documents required to perfect, continue or renew Seller's security interest in the Products.

7. **CANCELLATION:** Unless otherwise agreed, Buyer may cancel all or any part of the order by written notice received by Seller before the completion of the order. On receipt of such cancellation notice, all work on the order or part thereof canceled will be stopped as promptly as is reasonably possible. Buyer will then be invoiced for and will pay to Seller as liquidated damages a cancellation charge. For completed items, the charge will be equal to their established prices. For items not completed, the charge will be equal to 135% of Seller's full cost as determined by Seller in accordance with Seller's standard accounting practices (which includes burden and overhead), plus a charge for any packing and storage, less a credit for the balance of the material as scrap.

8. **RETURNS:** All returned items require a Return Merchandise Authorization (RMA) number from DME. Returns are subject to a quality inspection to validate whether it can be returned to inventory. Mold bases, plates, special components, made-to-order products and other date-sensitive products are non-returnable items. Items returned to DME without prior authorization (RMA) may be returned to sender. Items returned for stated defect or non-conforming reason require detailed explanation. No products are returnable beyond 30 days after receipt.

9. **CONFIDENTIALITY.** Any nonpublic information, including without limitation, Seller's pricing information and the contents of Seller's quotation or proposal and Buyer's purchase order, exchanged between the parties is deemed confidential ("Confidential Information"). Each party agrees to maintain the other party's Confidential Information in confidence, to not disclose the same to any third parties, and to use it only in connection with this sale. These restrictions shall expire two (2) years after the date of disclosure. This provision does not modify or supersede any separate confidentiality or nondisclosure contract signed by the parties.

10. **FORCE MAJEURE:** Seller shall not be liable for any delay in performance or nonperformance which is due to war, fire, flood, pandemic, acts of God, acts of third parties, acts of governmental authority or any agency or commission thereof, accident, breakdown of products, differences with employees or similar or dissimilar causes beyond Seller's reasonable control, including but not limited to, those interfering with production, supply or transportation of products, raw materials or components or Seller's ability to obtain, on terms Seller deem reasonable, material, labor, products or transportation.

11. **MERGER CLAUSE:** This Contract entirely supersedes any prior oral or written representations, correspondence, proposals, or contracts between the parties regarding the products. This writing constitutes the final and total expression of such contract between the parties, and it is a complete and exclusive statement of the terms of that contract.

12. **ASSIGNMENT:** Neither party may assign this Contract without the written consent of the other party, except that Seller may assign this Contract to a third party that acquires substantially all of Seller's assets and Seller may assign the flow of funds arising out of this Contract.

13. **COMPLIANCE WITH LAWS.** Each party agrees to comply with all applicable laws in the performance of its obligations; Buyer shall not trans-ship, re-export, divert or redirect Products outside of the original country of delivery without Seller's prior written consent.

14. **GOVERNING LAW:** This Contract shall be governed by and construed in accordance with the laws of the State of Michigan, without regard to the Convention for the International Sale of Goods (CISG), which shall not apply.



Sales and Ordering Information

U.S.A.

TERMS AND CONDITIONS OF SALE: See previous page.

PHONE ORDERS – TOLL FREE: 800-626-6653. DME's Customer Service Dept. operates Monday through Friday from 7 a.m. to 7 p.m. E.S.T. Calls can be made from anywhere in the continental U.S. and Puerto Rico (Puerto Rico: use "137" prefix instead of "1"). Our Customer Service Representatives will be happy to answer your questions on DME products or services, provide on-the-spot feedback on product availability and shipping details, or take any messages you wish relayed to your local DME sales, manufacturing or technical service representatives.

MAIL ORDERS: If you prefer to order by mail, please address your order to:
DME Company, 29111 Stephenson Highway, Madison Heights, Michigan 48071
ATTN: Customer Service Dept.

FAX: You may fax your order to:
DME Customer Service
248-544-5113 • 888-808-4363

CHECKS OR MONEY ORDERS: When paying invoices by check or money order, please make payable to *DME Company*. Include remittance copy of invoice and mail to:
DME Company, PO Box 854867 Minneapolis, MN 55485-4867

WALK-IN ORDERS, PICK-UPS AND RETURNS: If desired, ordered products in stock at your nearest DME Service Center can be picked up rather than shipped. Walk-in orders at Service Center locations can also be processed while you wait. Products being returned for repair or exchange should be processed through Customer Service prior to being returned.

SPECIAL MACHINING SERVICES: Prints for quotation on special machining work can be sent by EDI to dme_cad@dme.net or mailed to the Estimating Department of the DME manufacturing location nearest you. Call our toll-free number if desired to clarify location which serves your area.

Estimating locations are:

- 1117 Fairplains Street, Greenville, MI 48838, Tel. 616-754-4601
- 3275 Deziel Drive, Windsor, Ont N8W 5A5, Tel. 519-948-5001

Please add "DME Company" and "Attn: Estimating Dept." to above addresses when mailing prints. To obtain prices and delivery on special mold base orders or to check status of special work in progress please contact Customer Service.

CANADA

TERMS AND CONDITIONS OF SALE: See previous page.

ORDERS, QUOTES, PICKUPS, RETURNS: Please contact 800-387-6600.

CHECK OR MONEY ORDERS: Make payable to *DME Company*. Include remittance copy of invoice and mail to:

32745 Deziel Drive, Windsor, ON N8W 5A5.

UF

MUD® Quick-Change Systems from DME

MUD

Quick-Change Mold Frames & Inserts for U-Style

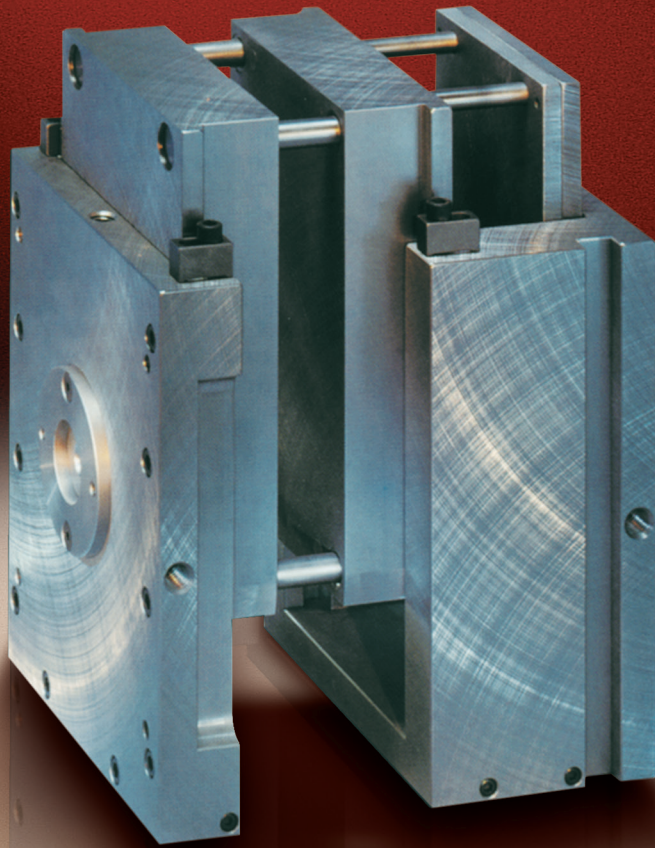

MUD® Quick-Change Mold Frames & Inserts for U-Style | Ordering Information

Frame Ordering Information

- Item number and description (see tables on respective page)
- “S” diameter of locating ring supplied standard (see drawings on respective page)
- Sprue bushing (if required) “R” spherical radius of sprue bushing furnished 1/2” or 3/4” unless otherwise shown “O” small diameter of sprue bushing orifice furnished 5/32”, 7/32”, 9/32” or 11/32” unless otherwise shown
- Optional locating rings and sprue bushings available on request
- Knockout hole locations standard as shown (others optional)
- Clamp slots standard unless otherwise shown on respective page
- Mounting holes optional unless shown on respective page
- Adapter plates optional
- Additional height of ejection available (quotation on request)
- Frames standard in prehard #2 steel. Prehard stainless and other steel grades available (quotation on request)
- Other frame options are available on request

Insert Mold Ordering Information

- Item number and description (see tables on respective page)
- Steel grades – 1020, 4130 prehard, P-20 prehard and H-13: 420 stainless and other grades on request
- T-style laminated insert molds supplied with 4130 prehard ear plates except tool steel insert molds have tool steel ear plates
- H-13 and other tool steel insert molds supplied .010 oversize on outside dimension, .010 – .013 oversize on thickness, and .025 – .035 undersize in pin and bushing holes for machining after required heat treating
- “A” and “B” dimensions supplied .004 – .007 oversize unless otherwise specified
- Other “A” and “B” thicknesses available on request

Quick-Change U frame features and applications

This MUD[®] Quick-Change frame and companion insert mold series combines the cost saving benefits and time saving advantages of the Master Unit Die Concept with exceptional design flexibility.

U frames accept two types of companion insert molds — the standard style (inside frame width) and T-style (outside frame width) companion insert molds. These can be ordered in any thickness in which the frame and insert stack height do not exceed the minimum or maximum shut height of the machine. The frame's open design permits installation of water lines or hydraulic cylinders on any side of the insert mold. Options include insulation boards, master ejector plates and master ejector plates with interlocking rails.

MUD[®] Quick-Change U frames can be adapted to multiple insert mold applications with the addition of an optional removable center runner bar and master ejector plate. This allows simultaneous production with two smaller insert molds in either the T-style or standard style.

Other U frame series cost reduction options include frame spacer bars and adapter rails. Spacer bars permit the use of shorter and lower cost companion insert molds in frames designed for longer sizes. Adapter rails permit the use of narrower and lower cost insert molds in frames designed for wider sizes.

Steel Specifications: Standard U frames are produced in prehard steel (285-325 Brinell). Prehard stainless, 420 stainless, H-13 and other grades are available on request. Frame coatings can be specified.

Guide rails on larger frames are treated for enhanced wear resistance.

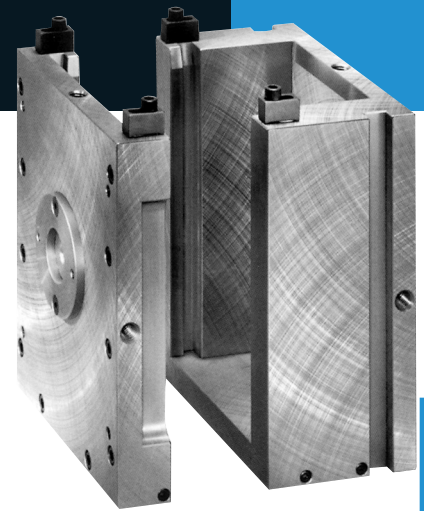

Quick-Change U frame options

- Removable center runner bars for two-insert mold applications
- Master ejector plates
- Master ejector plates with interlocking rails
- Frame spacer bars
- Adapter rails
- Hot sprue bushings
- Insulation boards
- Additional height on ejector rails
- Coating options
- Electroless nickel plating

NOTE: Specifications subject to change without prior notice.

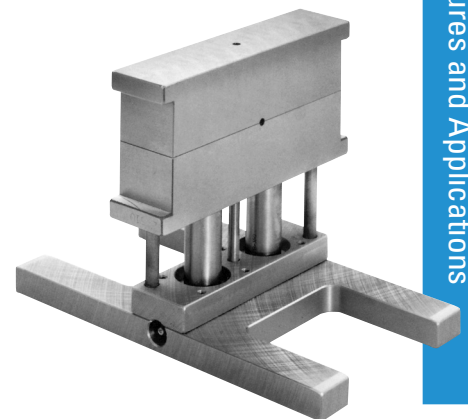

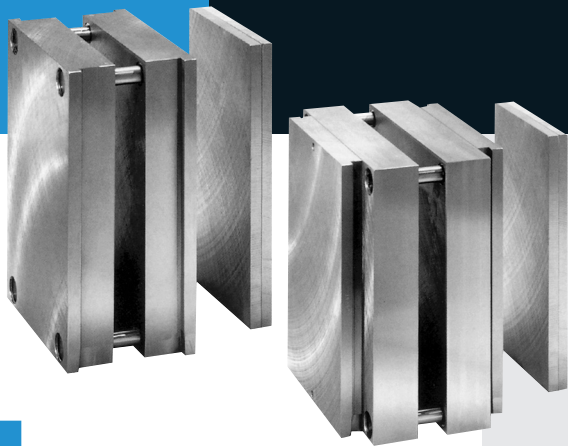

Companion insert mold features and applications

The two companion insert mold styles available with the Quick-Change U frame increase the exceptional design flexibility of this series. A wide range of options adds to this versatility. The result is the most versatile injection molding tooling offered to the industry.

T-style insert molds offer the maximum projected mold area and are available in laminated construction including three- and four-plate designs. Smaller sizes are available in either solid or laminated construction.

Standard insert molds are the most economical style and are recommended when the additional width of the T-style is not required. Standard insert molds are available in solid or laminated construction including three- and four-plate designs.

Both style insert molds can be ordered with a complete ejector system including return pins and pillar posts. Other options include stripper plates, sleeve ejection and three-plate construction for a pinpoint gating system. Machining for heater cartridge holes, water lines, rough or finished pockets, taper locks and other special applications is also available. As noted, the open design of the U frame permits installation of water lines or hydraulic cylinders on any side of the insert molds.

Design options for insert molds include spring loading, early return, unscrewing mechanisms, hot sprue bushings, hot runner molding and machining for cam slides. Insert molds can be ordered with interlocking ejector plates for positive return and stroking action when used with frames having an interlocking ejector system.

Steel Specifications: Companion insert molds are available in 1020, 4130 prehard, P-20 prehard and H-13. 420 stainless and other grades are available on request. Ear plates for T-style laminated insert molds are supplied 4130 steel with the exception of tool steel insert molds which are supplied with tool steel ear plates.

Companion insert mold options

- T-style insert molds in laminated construction
- Standard insert molds in solid or laminated construction
- Three-plate design for pinpoint gating
- Stripper plates
- Sleeve ejection
- Return pins and pillar posts
- Machining for taper locks
- Heater cartridge holes
- Machining for water lines
- Rough cut pockets
- Finished custom pockets
- Hot runner molding
- Machining for special applications

NOTE: Specifications subject to change without prior notice.



Enhanced Series Mold Inserts Solid & Laminated

SOLID

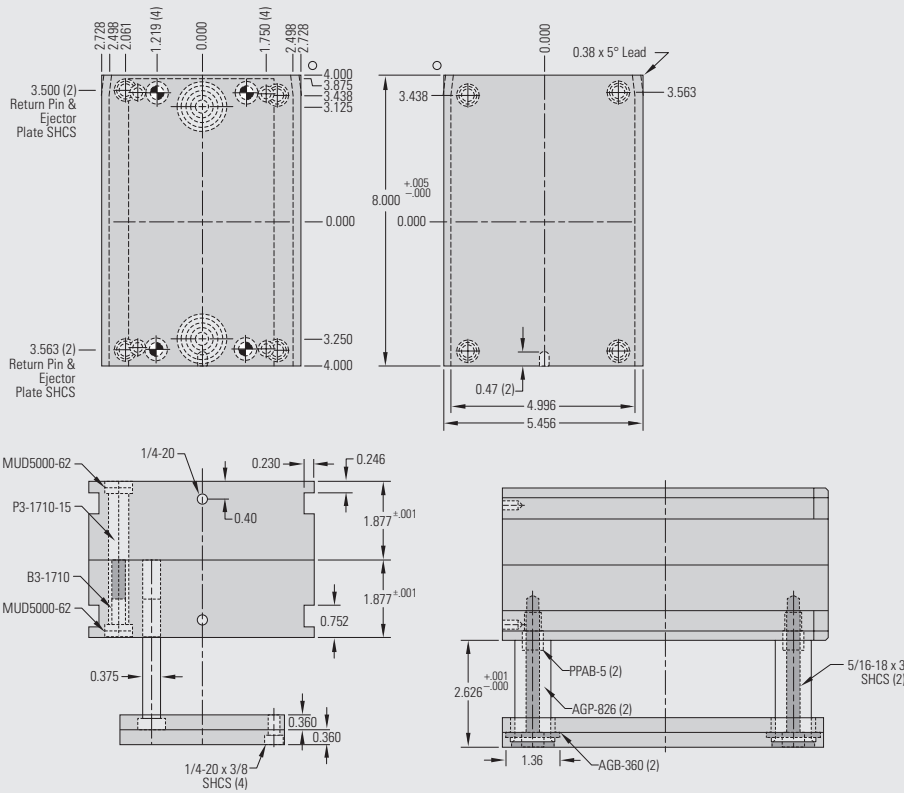

LAMINATED

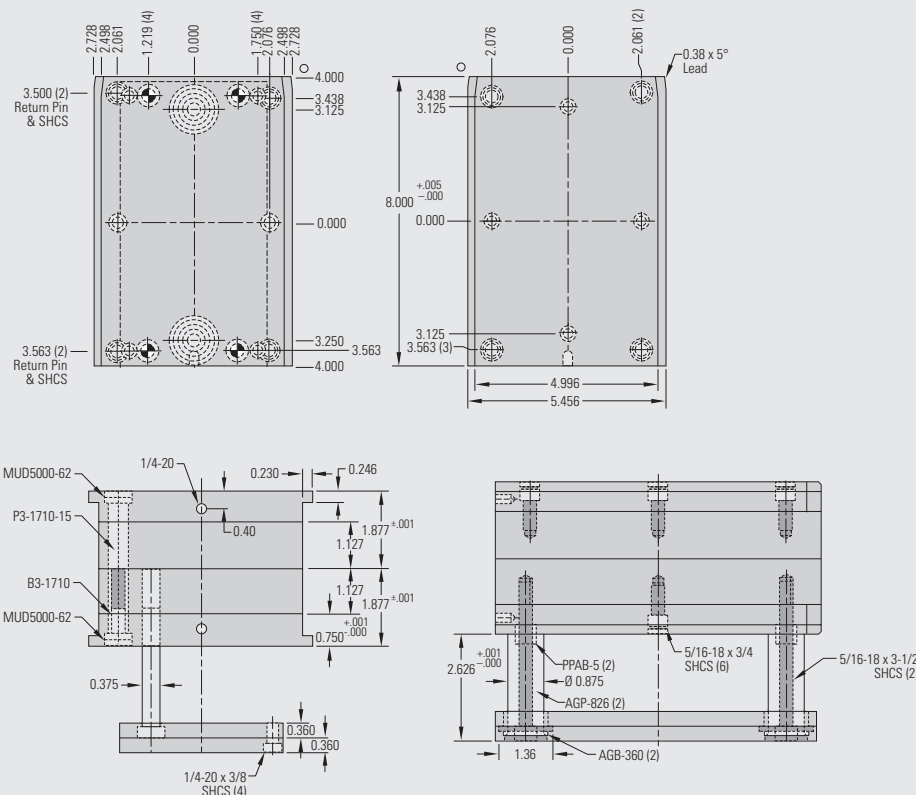

- Provides room for thicker pocket walls
- Reduces machine setup time by providing more surface area for clamping
- Ejector plates are bolted together for maximum convenience
- Compatible with the MUD® Quick-Change U Frame
- Installed with four leader pins and bushings, four return pins, and eyebolt holes
- All-in-one post guides ejection, retains the ejection system and provides support without the use of additional support pillars
- Tapped hole for insert removal
- Finish-ground parting line plates
- Optional .480 thick ejector plates
- 08/09 Series mold inserts available in DME #2 and #3 type steels
- Parting line plates bolt to the ear plates (Laminated only)
- Other sizes available on request
- All enhanced inserts are quoted upon request

MUD® Quick-Change Mold Frames & Inserts for U-Style | Solid & Laminated – Enhanced Series



UF Quick-Change U-Style Frame & Companion Insert Molds

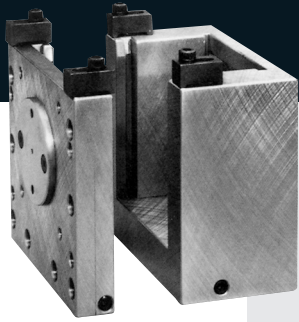

Frame

ITEM NO.
05/05 UF 321

NOTE: Use of spacers allows this frame to accept MUD® 3.25 x 3.15 insert molds (see page OP 146).

UF 321 Frame Upper – Side View

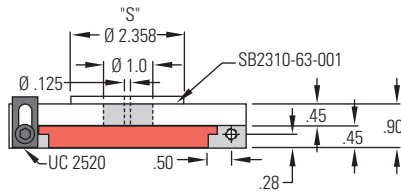

NOTE: Sprue bushing supplied flat with .125 small diameter orifice standard.

UF 321 Frame Upper – Top View

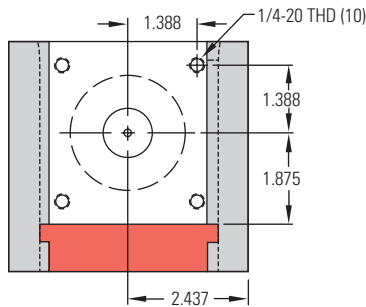

UF 321 Frame Lower – Side View

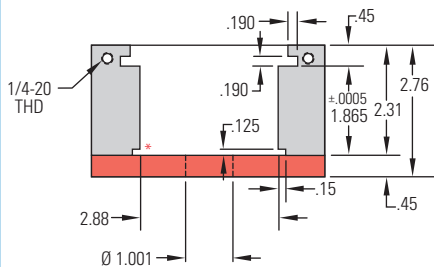

* O degree - 15 minute taper slot to accommodate sleeve ejection retainer plate. Slot tapers from .125 to .109 in 3.750 length.

UF 321 Frame Lower – Top View

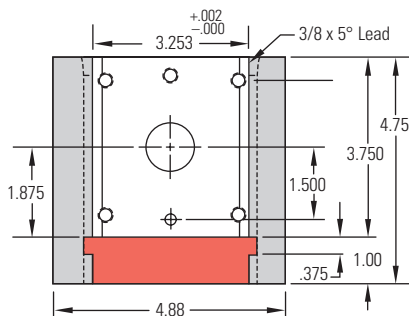

Companion Interchangeable Insert Molds

- 1 Frame clamps at this end of insert mold and ejector plates are flush with this end of insert.
- 2 Support post not supplied. Grind +.001 to +.002 higher than height of ejection (see page C 131).
- 3 Thicker plate optional.

Standard Solid:
3.25 x 3.75

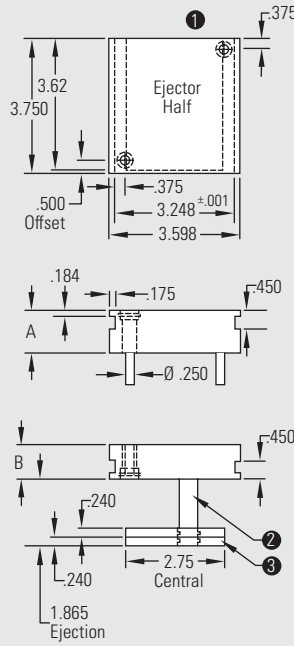

Standard Laminated:
3.25 x 3.75

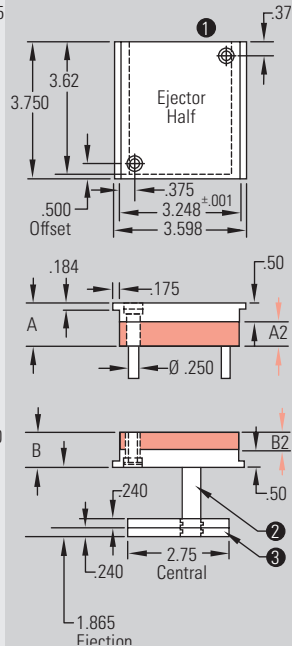

T-Style Laminated: 4.0
x 4.7

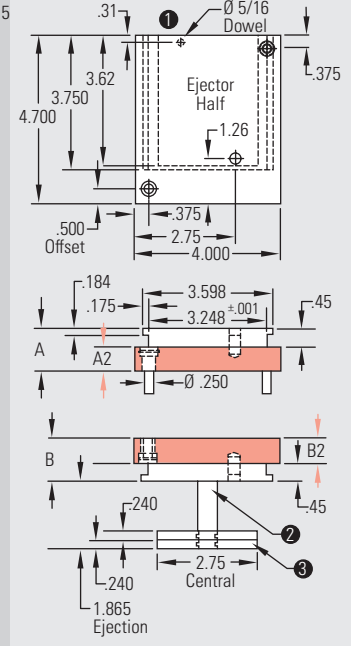

Standard Solid Construction

ITEM NO.	A	B
05/05 SSU 221	1.377	1.377
05/05 SSU 222	1.877	1.877

Standard Laminated Construction

ITEM NO.	A	A2	B2	B
05/05 SLU 281	1.377	0.877	0.877	1.377
05/05 SLU 282	1.877	1.377	1.377	1.877

T-Style Laminated Construction

ITEM NO.	A	A2	B2	B
05/05 TLU 201	1.450	1.000	1.000	1.450
05/05 TLU 202	1.950	1.500	1.500	1.950

Ordering information for frame and companion insert molds can be found in the front of this section.



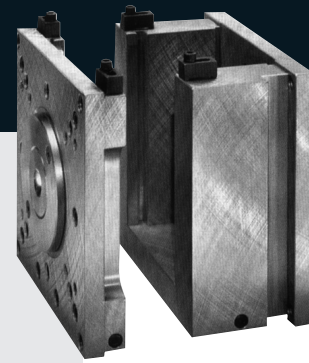

Frame

ITEM NO.
07/07 UF 321

Companion Interchangeable Insert Molds

- 1 Frame clamps at this end of insert mold and ejector plates are flush with this end of insert.
- 2 Support post not supplied. Grind +.001 to +.002 higher than height of ejection (see page C 131).
- 3 Thicker plate optional.

Standard Solid:
4.5 x 6.25

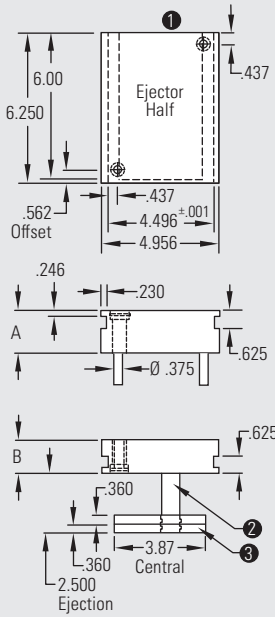

Standard Laminated:
4.5 x 6.25

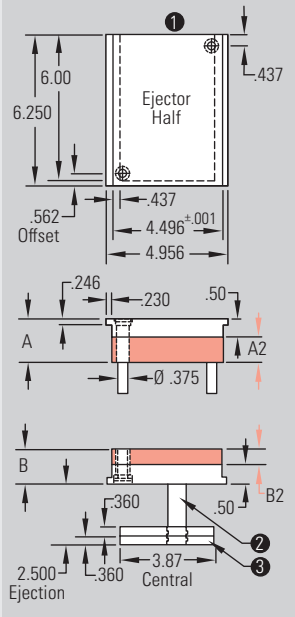

T-Style Solid or
Laminated: 6.0 x 7.25

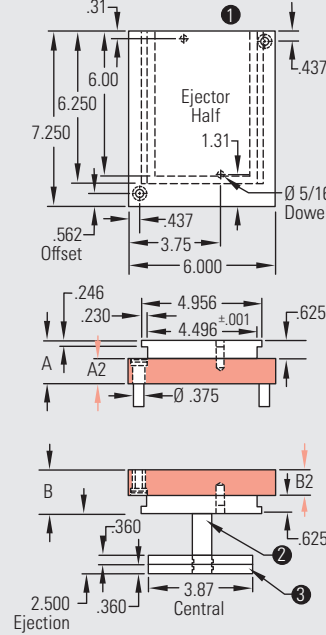

UF 321 Frame Upper – Side View

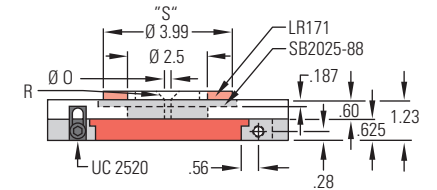

UF 321 Frame Upper – Top View

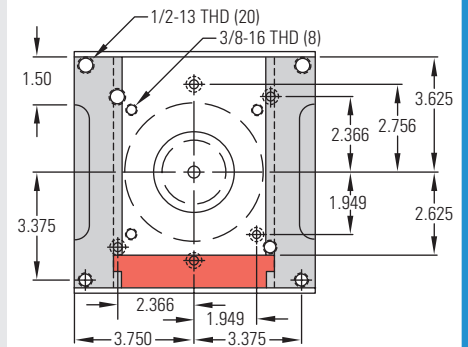

UF 321 Frame Lower – Side View

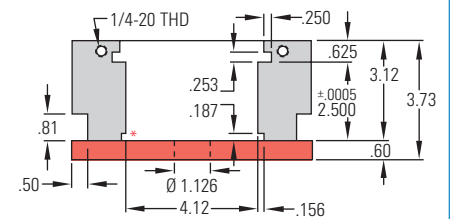

* 0 degree - 15 minute taper slot to accommodate sleeve ejection retainer plate. Slot tapers from .187 to .160 in 6.250 length.

UF 321 Frame Lower – Top View

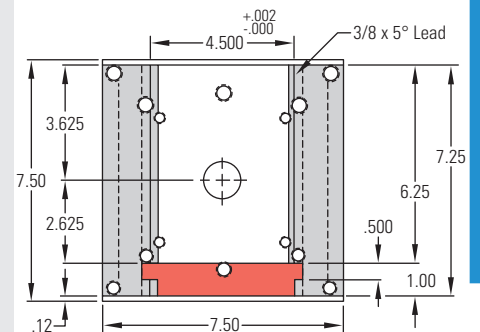

Standard Solid Construction

ITEM NO.	A	B
07/07 SSU 221	1.377	1.377
07/07 SSU 222	1.377	1.877
07/07 SSU 223	1.877	1.377
07/07 SSU 224	1.877	1.877

Standard Laminated Construction

ITEM NO.	A	A2	B2	B
07/07 SLU 281	1.377	0.877	0.877	1.377
07/07 SLU 282	1.377	0.877	1.377	1.877
07/07 SLU 283	1.877	1.377	0.877	1.377
07/07 SLU 284	1.877	1.377	1.377	1.877

T-Style Solid Construction

ITEM NO.	A	A2	B2	B
07/07 TSU 241	1.625	1.000	1.000	1.625
07/07 TSU 242	1.875	1.250	1.250	1.875

T-Style Laminated Construction

ITEM NO.	A	A2	B2	B
07/07 TLU 201	1.625	1.000	1.000	1.625
07/07 TLU 202	1.875	1.250	1.250	1.875

Ordering information for frame and companion insert molds can be found in the front of this section.





Frame

ITEM NO.
08/09 UF 321

UF Quick-Change U-Style Frame & Companion Insert Molds

Companion Interchangeable Insert Molds

- 1 Frame clamps at this end of insert mold and ejector plates are flush with this end of insert.
- 2 Support post not supplied. Grind +.001 to +.002 higher than height of ejection (see page C 131).
- 3 Thicker plate optional.

UF 321 Frame Upper – Side View

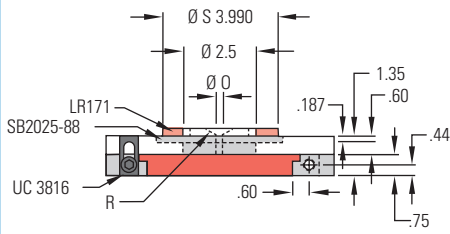

UF 321 Frame Upper – Top View

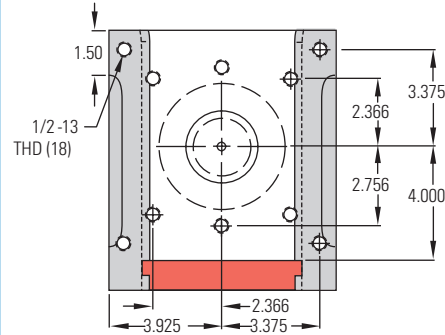

UF 321 Frame Lower – Side View

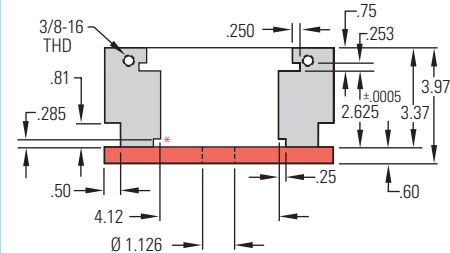

UF 321 Frame Lower – Top View

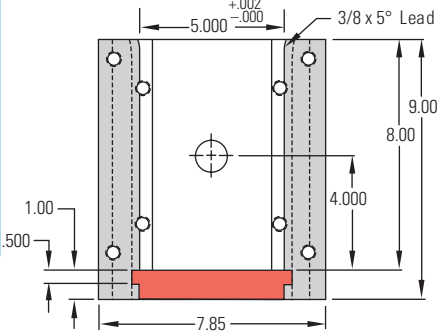

Standard Solid:
5.0 x 8.0

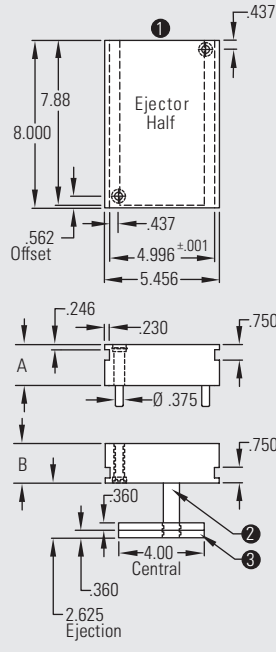

Standard Laminated:
5.0 x 8.0

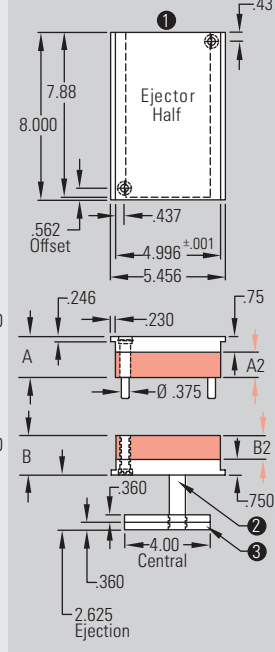

T-Style Solid or Laminated:
7.85 x 9.0

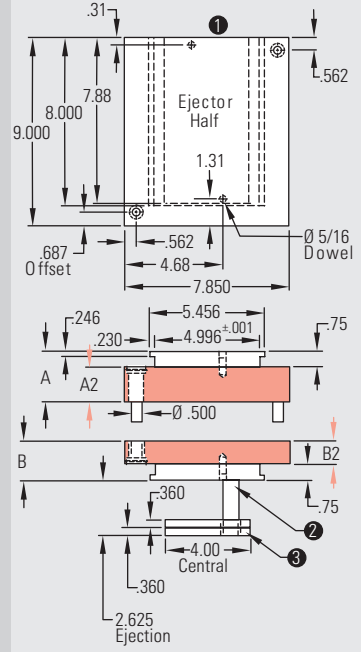

Standard Solid Construction

ITEM NO.	A	B
08/09 SSU 221	1.377	1.377
08/09 SSU 222	1.377	1.877
08/09 SSU 223	1.877	1.377
08/09 SSU 224	1.877	1.877
08/09 SSU 225	1.877	2.377
08/09 SSU 226	2.377	1.877
08/09 SSU 227	2.377	2.377
08/09 SSU 228	2.377	2.877
08/09 SSU 229	2.877	2.377
08/09 SSU 230	2.877	2.877

T-Style Solid Construction

ITEM NO.	A	A2	B2	B
08/09 TSU 241	1.750	1.000	1.000	1.750
08/09 TSU 242	1.750	1.000	1.500	2.250
08/09 TSU 243	2.000	1.250	1.250	2.000
08/09 TSU 244	2.250	1.500	1.000	1.750
08/09 TSU 245	2.250	1.500	1.500	2.250
08/09 TSU 246	2.625	1.875	1.875	2.625

Standard Laminated Construction

ITEM NO.	A	A2	B2	B
08/09 SLU 281	1.377	0.627	0.627	1.377
08/09 SLU 282	1.377	0.627	1.127	1.877
08/09 SLU 283	1.877	1.127	0.627	1.377
08/09 SLU 284	1.877	1.127	1.127	1.877
08/09 SLU 285	1.877	1.127	1.627	2.377
08/09 SLU 286	2.377	1.627	1.127	1.877
08/09 SLU 287	2.377	1.627	1.627	2.377
08/09 SLU 288	2.377	1.627	2.127	2.877
08/09 SLU 289	2.877	2.127	1.627	2.377
08/09 SLU 290	2.877	2.127	2.127	2.877

T-Style Laminated Construction

ITEM NO.	A	A2	B2	B
08/09 TLU 201	1.750	1.000	1.000	1.750
08/09 TLU 202	1.750	1.000	1.500	2.250
08/09 TLU 203	2.000	1.250	1.250	2.000
08/09 TLU 204	2.250	1.500	1.000	1.750
08/09 TLU 205	2.250	1.500	1.500	2.250
08/09 TLU 206	2.625	1.875	1.875	2.625

Solid Construction Aluminum Companion Insert Molds

ITEM NO.	A	B
08/09 ALU 208	1.875	1.875
08/09 ALU 210	2.375	1.875

NOTE: "A" & "B" dimensions are supplied ±.001 on all aluminum companion insert molds.

Ordering information for frame and companion insert molds can be found in the front of this section.

MUD® Quick-Change Mold Frames & Inserts for U-Style | 08/09 UF 321





Frame

ITEM NO.
08/10 UF 321

Companion Interchangeable Insert Molds

- 1 Frame clamps at this end of insert mold and ejector plates are flush with this end of insert.
- 2 Support post not supplied. Grind +.001 to +.002 higher than height of ejection (see page C 131).
- 3 Thicker plate optional.

Standard Solid:
5.0 x 9.0

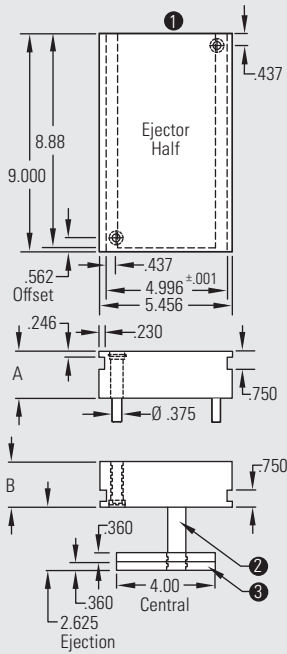

Standard Laminated:
5.0 x 9.0

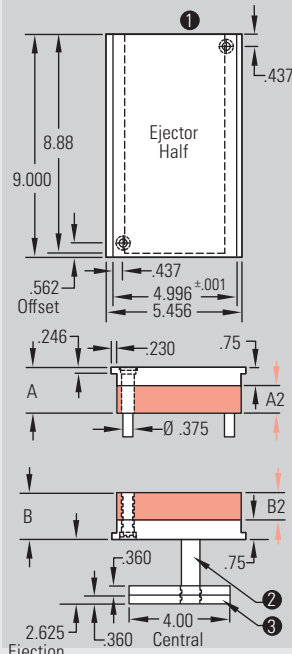

T-Style Solid or Laminated:
7.85 x 9.0

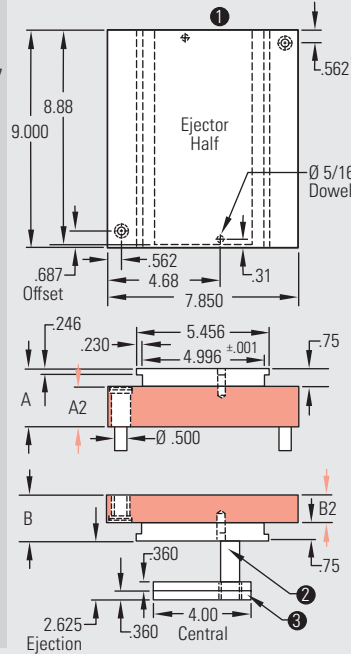

UF 321 Frame Upper – Side View

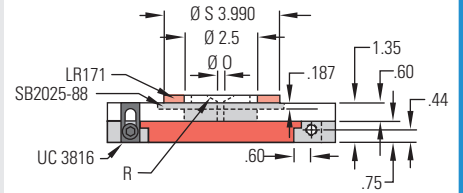

UF 321 Frame Upper – Top View

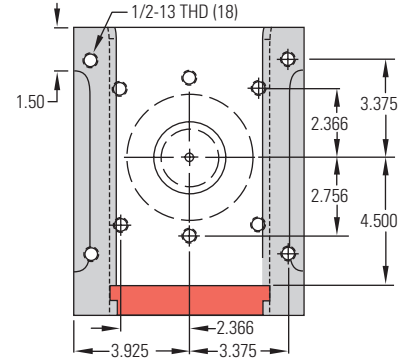

Standard Solid Construction

ITEM NO.	A	B
08/10 SSU 221	1.377	1.377
08/10 SSU 222	1.377	1.877
08/10 SSU 223	1.877	1.377
08/10 SSU 224	1.877	1.877
08/10 SSU 225	1.877	2.377
08/10 SSU 226	2.377	1.877
08/10 SSU 227	2.377	2.377
08/10 SSU 228	2.377	2.877
08/10 SSU 229	2.877	2.377
08/10 SSU 230	2.877	2.877

T-Style Solid Construction

ITEM NO.	A	A2	B2	B
08/10 TSU 241	1.750	1.000	1.000	1.750
08/10 TSU 242	1.750	1.000	1.500	2.250
08/10 TSU 243	2.000	1.250	1.250	2.000
08/10 TSU 244	2.250	1.500	1.000	1.750
08/10 TSU 245	2.250	1.500	1.500	2.250
08/10 TSU 246	2.625	1.875	1.875	2.625

Standard Laminated Construction

ITEM NO.	A	A2	B2	B
08/10 SLU 281	1.377	0.627	0.627	1.377
08/10 SLU 282	1.377	0.627	1.127	1.877
08/10 SLU 283	1.877	1.127	0.627	1.377
08/10 SLU 284	1.877	1.127	1.127	1.877
08/10 SLU 285	1.877	1.127	1.627	2.377
08/10 SLU 286	2.377	1.627	1.127	1.877
08/10 SLU 287	2.377	1.627	1.627	2.377
08/10 SLU 288	2.377	1.627	2.127	2.877
08/10 SLU 289	2.877	2.127	1.627	2.377
08/10 SLU 290	2.877	2.127	2.127	2.877

T-Style Laminated Construction

ITEM NO.	A	A2	B2	B
08/10 TLU 201	1.750	1.000	1.000	1.750
08/10 TLU 202	1.750	1.000	1.500	2.250
08/10 TLU 203	2.000	1.250	1.250	2.000
08/10 TLU 204	2.250	1.500	1.000	1.750
08/10 TLU 205	2.250	1.500	1.500	2.250
08/10 TLU 206	2.625	1.875	1.875	2.625

UF 321 Frame Lower – Side View

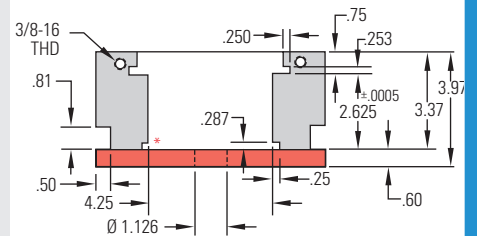

* O degree - 15 minute taper slot to accommodate sleeve ejection retainer plate. Slot tapers from .287 to .248 in 9.000 length.

UF 321 Frame Lower – Top View

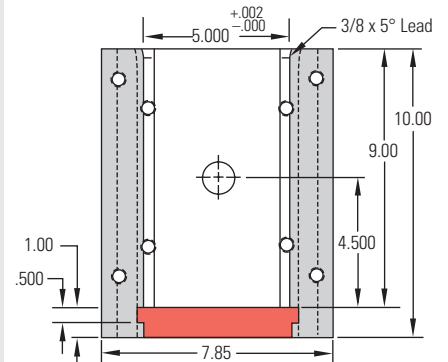

Ordering information for frame and companion insert molds can be found in the front of this section.



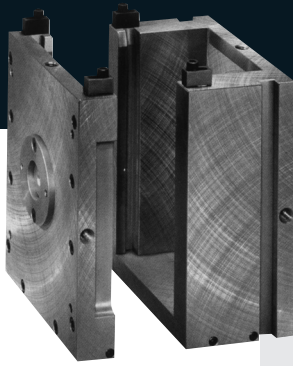

UF Quick-Change U-Style Frame & Companion Insert Molds

Frame

ITEM
NO.

94/90 UF 321

NOTE: For extended clamp bar option, see page OP 144.

UF 321 Frame Upper – Side View

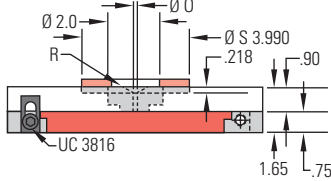

UF 321 Frame Upper – Top View

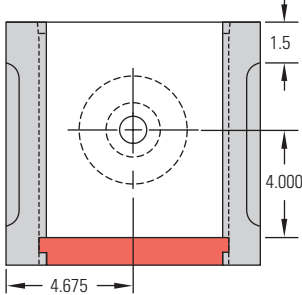

UF 321 Frame Lower – Side View

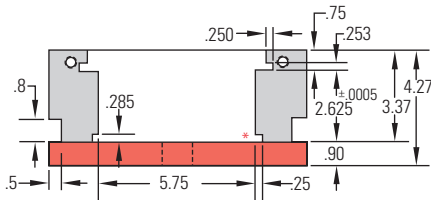

* O degree - 15 minute taper slot to accommodate sleeve ejection retainer plate. Slot tapers from .285 to .250 in 8.000 length.

UF 321 Frame Lower – Top View

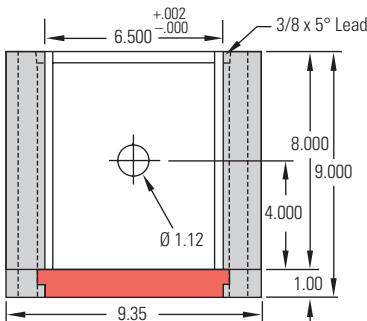

Companion Interchangeable Insert Molds

- 1 Frame clamps at this end of insert mold and ejector plates are flush with this end of insert.
- 2 Support post not supplied. Grind +.001 to +.002 higher than height of ejection (see page C 131).
- 3 Thicker plate optional.

Standard Solid:
6.5 x 8.0

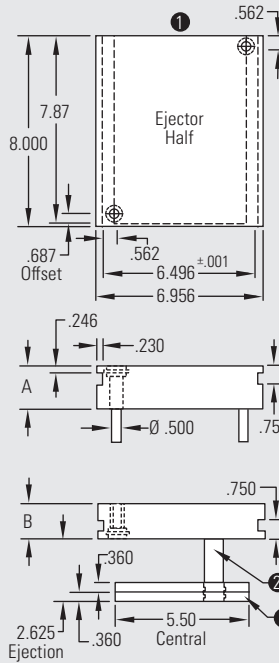

Standard Laminated:
6.5 x 8.0

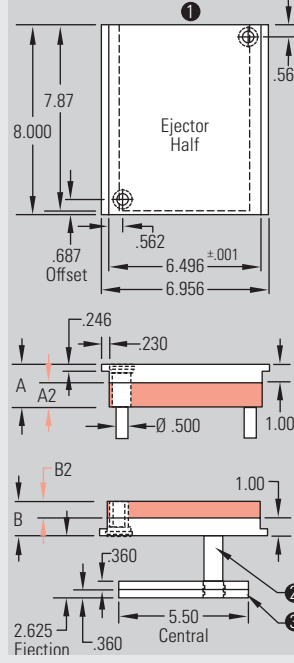

T-Style Solid or
Laminated: 8.4 x 9.0

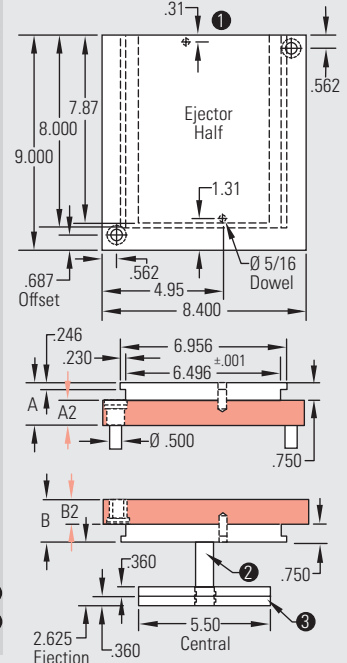

Standard Solid Construction

ITEM NO.	A	B
84/90 SSU 221	1.377	1.377
84/90 SSU 222	1.377	1.877
84/90 SSU 223	1.877	1.377
84/90 SSU 224	1.877	1.877
84/90 SSU 225	1.877	2.377
84/90 SSU 226	2.377	1.877
84/90 SSU 227	2.377	2.377
84/90 SSU 228	2.377	2.877
84/90 SSU 229	2.877	2.377
84/90 SSU 230	2.877	2.877

Standard Laminated Construction

ITEM NO.	A	A2	B2	B
84/90 SLU 281	1.877	0.877	0.877	1.877
84/90 SLU 282	1.877	0.877	1.377	2.377
84/90 SLU 283	2.377	1.377	0.877	1.877
84/90 SLU 284	2.377	1.377	1.377	2.377
84/90 SLU 285	2.377	1.377	1.877	2.877
84/90 SLU 286	2.877	1.877	1.377	2.377
84/90 SLU 287	2.877	1.877	1.877	2.877

T-Style Solid Construction

ITEM NO.	A	A2	B2	B
84/90 TSU 241	1.500	0.750	1.250	2.000
84/90 TSU 242	1.750	1.000	1.000	1.750
84/90 TSU 243	1.750	1.000	1.500	2.250
84/90 TSU 244	2.000	1.250	1.250	2.000
84/90 TSU 245	2.250	1.500	1.000	1.750
84/90 TSU 246	2.250	1.500	1.500	2.250
84/90 TSU 247	2.625	1.875	1.875	2.625

T-Style Laminated Construction

ITEM NO.	A	A2	B2	B
84/90 TLU 201	1.500	0.750	1.250	2.000
84/90 TLU 202	1.750	1.000	1.000	1.750
84/90 TLU 203	1.750	1.000	1.500	2.250
84/90 TLU 204	2.000	1.250	1.250	2.000
84/90 TLU 205	2.250	1.500	1.000	1.750
84/90 TLU 206	2.250	1.500	1.500	2.250
84/90 TLU 207	2.625	1.875	1.875	2.625

Solid Construction Aluminum Companion Insert Molds

ITEM NO.	A	B
84/90 ALU 210	2.375	1.875

NOTE: "A" & "B" dimensions are supplied ±.001 on all aluminum companion insert molds.

Ordering information for frame and companion insert molds can be found in the front of this section.





Frame

ITEM NO.
84/90 UF 321

Companion Interchangeable Insert Molds

- 1 Frame clamps at this end of insert mold and ejector plates are flush with this end of insert.
- 2 Support post not supplied. Grind +.001 to +.002 higher than height of ejection (see page C 131).
- 3 Thicker plate optional.

Standard Solid:
6.5 x 8.0

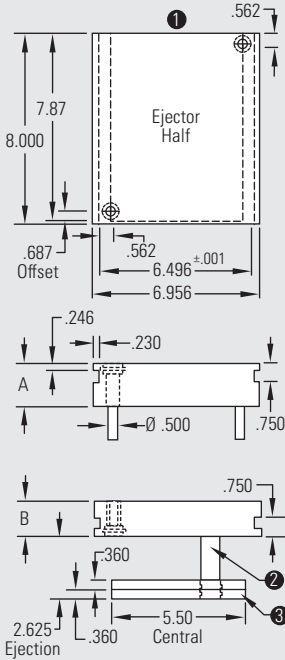

Standard Laminated:
6.5 x 8.0

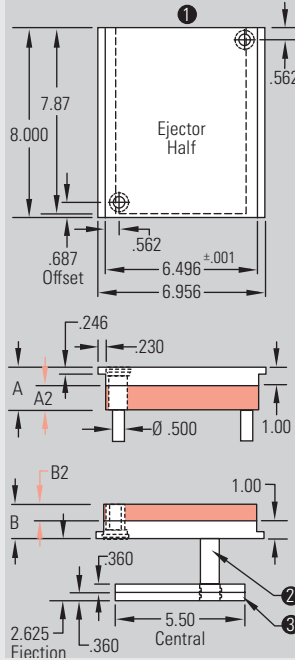

T-Style Solid or Laminated: 8.4 x 9.0

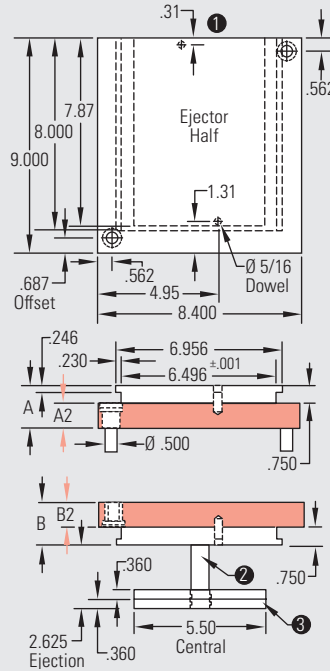

Standard Solid Construction

ITEM NO.	A	B
84/90 SSU 221	1.377	1.377
84/90 SSU 222	1.377	1.877
84/90 SSU 223	1.877	1.377
84/90 SSU 224	1.877	1.877
84/90 SSU 225	1.877	2.377
84/90 SSU 226	2.377	1.877
84/90 SSU 227	2.377	2.377
84/90 SSU 228	2.377	2.877
84/90 SSU 229	2.877	2.377
84/90 SSU 230	2.877	2.877

T-Style Solid Construction

ITEM NO.	A	A2	B2	B
84/90 TSU 241	1.500	0.750	1.250	2.000
84/90 TSU 242	1.750	1.000	1.000	1.750
84/90 TSU 243	1.750	1.000	1.500	2.250
84/90 TSU 244	2.000	1.250	1.250	2.000
84/90 TSU 245	2.250	1.500	1.000	1.750
84/90 TSU 246	2.250	1.500	1.500	2.250
84/90 TSU 247	2.625	1.875	1.875	2.625

T-Style Laminated Construction

ITEM NO.	A	A2	B2	B
84/90 TLU 201	1.500	0.750	1.250	2.000
84/90 TLU 202	1.750	1.000	1.000	1.750
84/90 TLU 203	1.750	1.000	1.500	2.250
84/90 TLU 204	2.000	1.250	1.250	2.000
84/90 TLU 205	2.250	1.500	1.000	1.750
84/90 TLU 206	2.250	1.500	1.500	2.250
84/90 TLU 207	2.625	1.875	1.875	2.625

Solid Construction Aluminum Companion Insert Molds

ITEM NO.	A	B
84/90 ALU 210	2.375	1.875

NOTE: "A" & "B" dimensions are supplied ±.001 on all aluminum companion insert molds.

Standard Laminated Construction

ITEM NO.	A	A2	B2	B
84/90 SLU 281	1.877	0.877	0.877	1.877
84/90 SLU 282	1.877	0.877	1.377	2.377
84/90 SLU 283	2.377	1.377	0.877	1.877
84/90 SLU 284	2.377	1.377	1.377	2.377
84/90 SLU 285	2.377	1.377	1.877	2.877
84/90 SLU 286	2.877	1.877	1.377	2.377
84/90 SLU 287	2.877	1.877	1.877	2.877

Ordering information for frame and companion insert molds can be found in the front of this section.

UF 321 Frame Upper – Side View

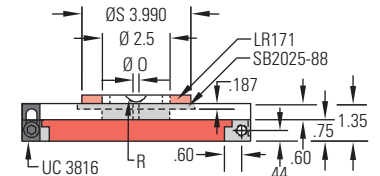

UF 321 Frame Upper – Top View

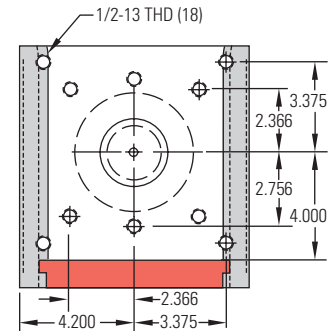

UF 321 Frame Lower – Side View

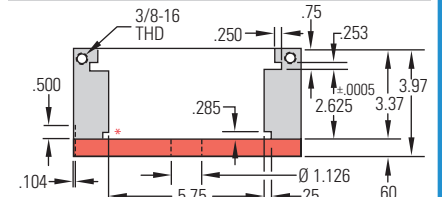

* 0 degree - 15 minute taper slot to accommodate sleeve ejection retainer plate. Slot tapers from .285

UF 321 Frame Lower – Top View

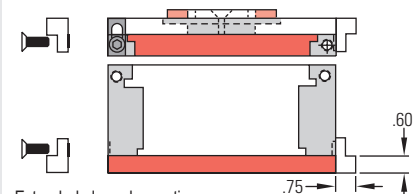
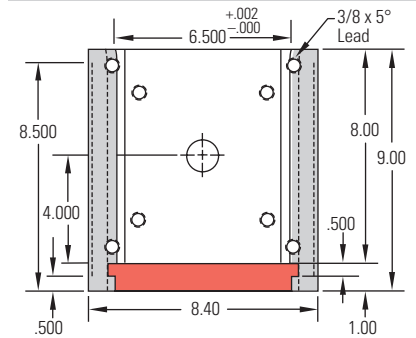

Extended clamp bar option:
Set of four (4) bars required.
See page OP 144.



MUD® Quick-Change Mold Frames & Inserts for U-Style | 84/90 UF 321

UF Quick-Change U-Style Shuttle Frame & Companion Insert Molds

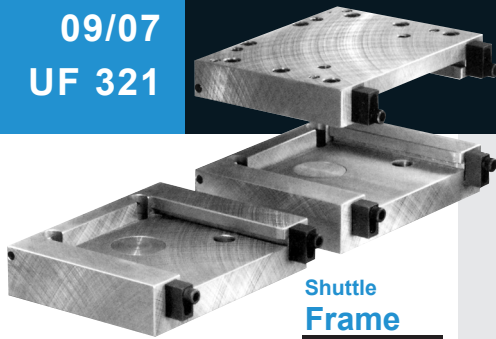

Shuttle Frame

ITEM NO.
09/07 UF 321

UF 321 Frame Upper – Side View

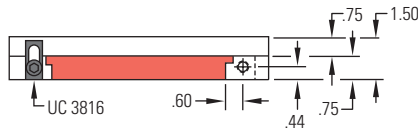

UF 321 Frame Upper – Top View

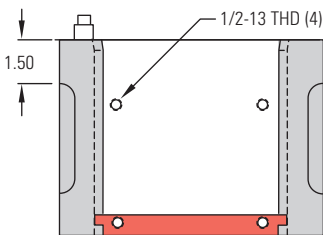

UF 321 Frame Lower – Side View

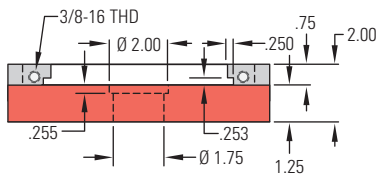

UF 321 Frame Lower – Top View

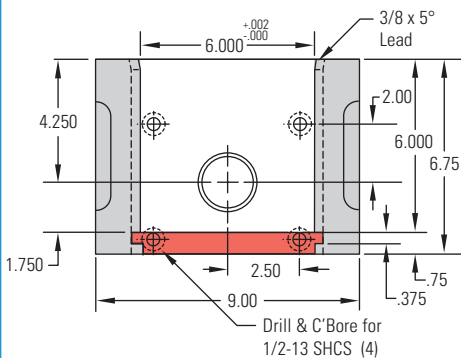

KO Rod Spacer

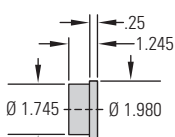

Two (2) required.

Knockout rod spacer standard as shown.

NOTE: Insert molds can be ordered with two (2) "B" halves by noting "S" after catalog code number.

Companion Interchangeable Insert Molds

1 Frame clamps at this end of insert mold.

Standard Solid:
6.0 x 6.75

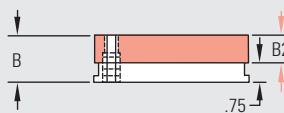
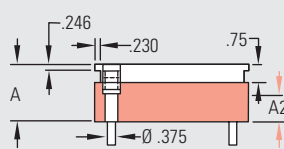
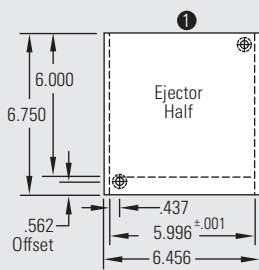

T-Style Solid or Laminated: 9.0 x 6.75

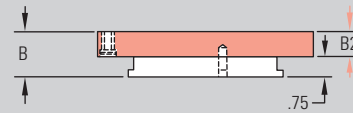
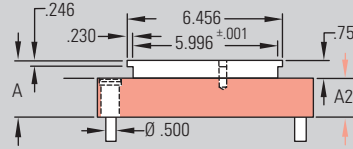
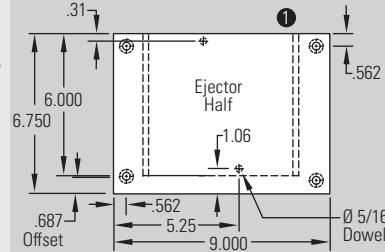

Optional

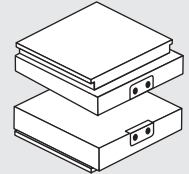

Hardened runner pads available (quotation on request).

Standard Solid Construction

ITEM NO.	A	A2	B2	B
09/07 SSU 221	2.250	1.500	1.500	2.250

T-Style Solid Construction

ITEM NO.	A	A2	B2	B
09/07 TSU 241	2.250	1.500	1.500	2.250

T-Style Laminated Construction

ITEM NO.	A	A2	B2	B
09/07 TLU 201	2.250	1.500	1.500	2.250

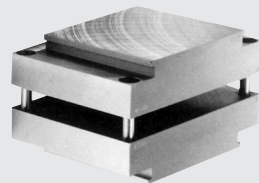
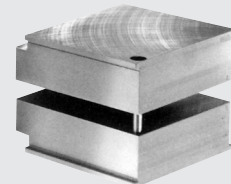

Ordering information for frame and companion insert molds can be found in the front of this section.

NOTE: When ejection is required, pockets can be machined in ejector half of insert mold and ejector plates installed.



EB Quick-Change U-Style Shuttle Frame & Companion Insert Molds

09/07
EB 321

Shuttle
Frame

ITEM
NO.

09/07 EB 321

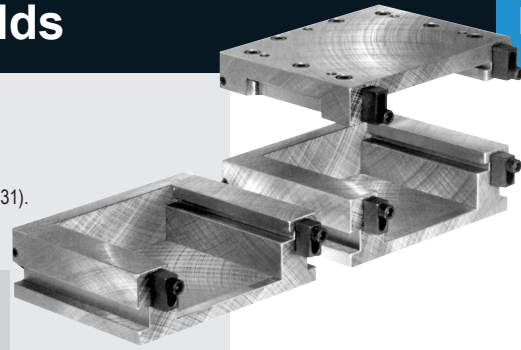

Companion Interchangeable Insert Molds

- 1 Frame clamps at this end of insert mold and ejector plates are flush with this end of insert.
- 2 Support post not supplied. Grind +.001 to +.002 higher than height of ejection (see page C 131).
- 3 Thicker plate optional.

Standard Solid:
6.0 x 6.75

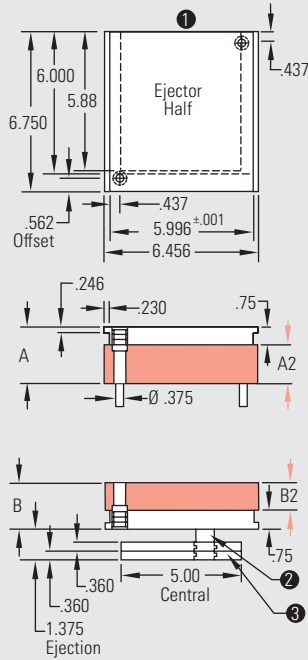

T-Style Solid or
Laminated: 9.0 x 6.75

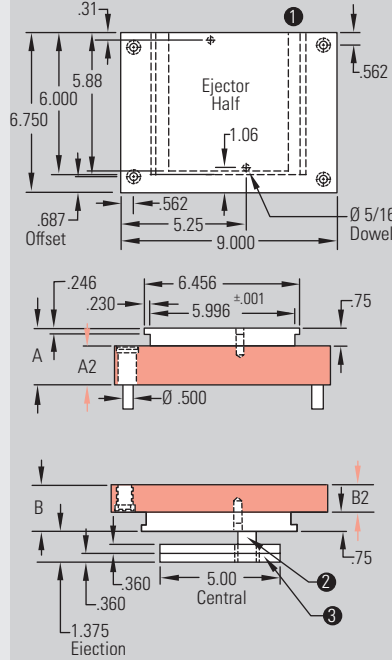

Optional

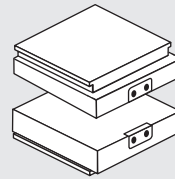

Hardened runner pads
available (quotation on
request).

EB 321 Frame Upper – Side View

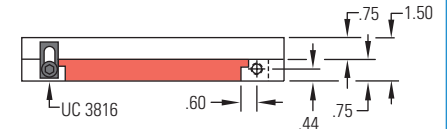

EB 321 Frame Upper – Top View

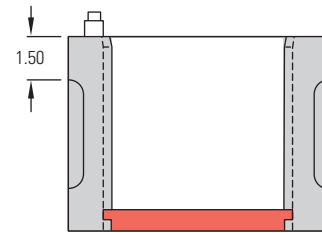

Cavity half, one (1) required.

EB 321 Frame Lower – Side View

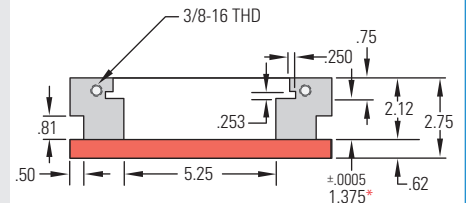

* Height of ejection can be modified to suit nozzle height of machine (quotation on request).

EB 321 Frame Lower – Top View

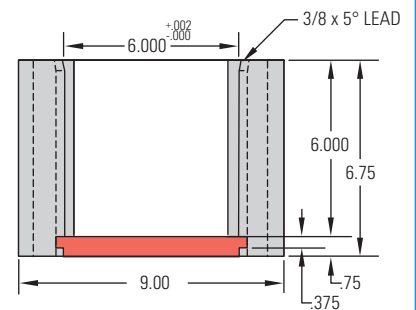

Ejector half, two (2) required.

NOTE: Insert molds can be ordered with two (2) "B" halves by noting "S" after catalog code number.

NOTE: Knockout hole locations per customer specifications (if required).

Standard Solid Construction

ITEM NO.	A	A2	B2	B
09/07 SSE 221	2.250	1.500	1.500	2.250

T-Style Solid Construction

ITEM NO.	A	A2	B2	B
09/07 TSE 241	2.250	1.500	1.500	2.250

T-Style Laminated Construction

ITEM NO.	A	A2	B2	B
09/07 TLE 201	2.250	1.500	1.500	2.250

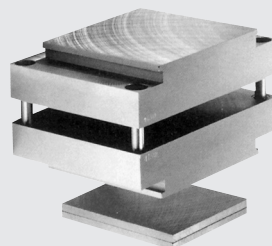
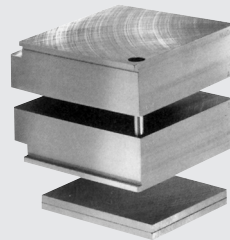

Ordering information for frame and companion insert molds can be found in the front of this section.



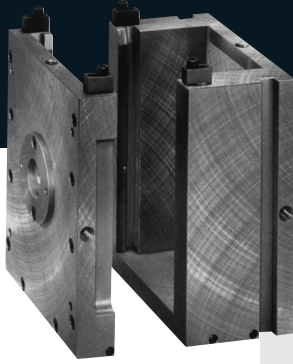

UF Quick-Change U-Style Frame & Companion Insert Molds

Frame

ITEM NO.
10/12 UF 321

Companion Interchangeable Insert Molds

- 1 Frame clamps at this end of insert mold and ejector plates are flush with this end of insert.
- 2 Support post not supplied. Grind $+.001$ to $+.002$ higher than height of ejection (see page C 131).
- 3 Thicker plate optional (quotation on request).
- 4 $3/4 \times 5^\circ$ lead this end.

UF 321 Frame Upper – Side View

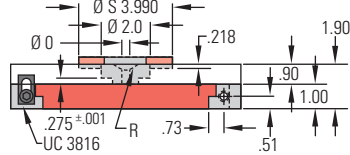

UF 321 Frame Upper – Top View

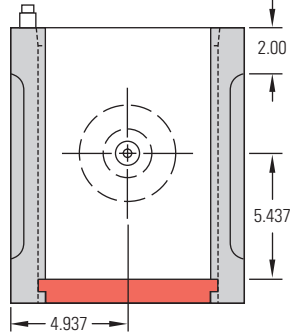

UF 321 Frame Lower – Side View

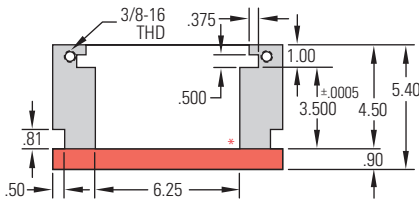

* Taper slot to accommodate sleeve ejection optional (quotation on request)

UF 321 Frame Lower – Top View

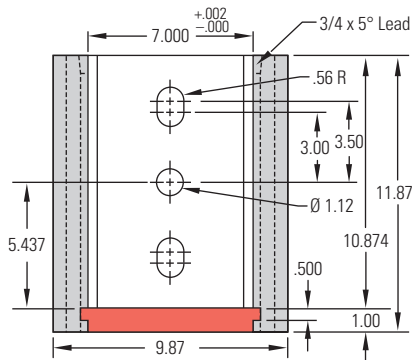

Frame supplied with or without sprue bushing

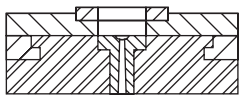

Standard Solid:
7.0 x 10.9

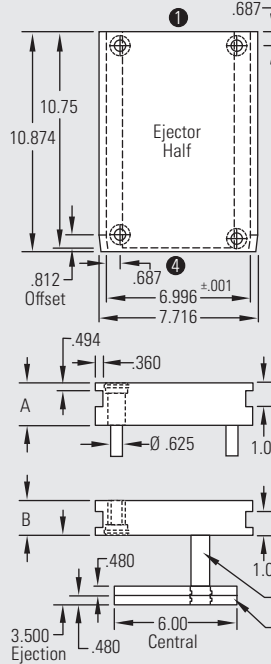

Standard Laminated:
7.0 x 10.9

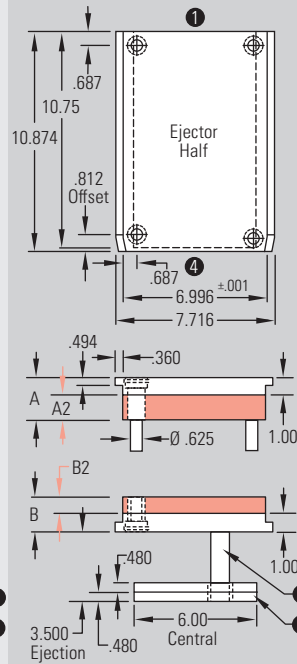

T-Style Laminated: 9.9
x 10.9

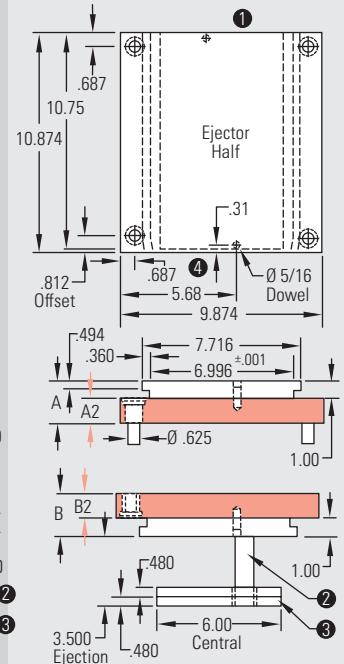

Standard Solid Construction

ITEM NO.	A	B
10/12 SSU 221	1.377	1.377
10/12 SSU 222	1.377	1.877
10/12 SSU 223	1.877	1.377
10/12 SSU 224	1.877	1.877
10/12 SSU 225	1.877	2.377
10/12 SSU 226	2.377	1.877
10/12 SSU 227	2.377	2.377
10/12 SSU 228	2.377	2.877
10/12 SSU 229	2.877	2.377
10/12 SSU 230	2.877	2.877

T-Style Laminated Construction

ITEM NO.	A	A2	B2	B
10/12 TLU 201	1.877	0.877	0.877	1.877
10/12 TLU 202	1.877	0.877	1.377	2.377
10/12 TLU 203	2.377	1.377	0.877	1.877
10/12 TLU 204	2.377	1.377	1.377	2.377
10/12 TLU 205	2.377	1.377	1.877	2.877
10/12 TLU 206	2.877	1.877	1.377	2.377
10/12 TLU 207	2.877	1.877	1.877	2.877
10/12 TLU 208	2.877	1.877	2.377	3.377
10/12 TLU 209	3.377	2.377	1.877	2.877
10/12 TLU 210	3.377	2.377	2.377	3.377

Standard Laminated Construction

ITEM NO.	A	A2	B2	B
10/12 SLU 281	1.877	0.877	0.877	1.877
10/12 SLU 282	1.877	0.877	1.377	2.377
10/12 SLU 283	1.877	0.877	1.877	2.877
10/12 SLU 284	2.377	1.377	0.877	1.877
10/12 SLU 285	2.377	1.377	1.377	2.377
10/12 SLU 286	2.377	1.377	1.877	2.877
10/12 SLU 287	2.877	1.877	0.877	1.877
10/12 SLU 288	2.877	1.877	1.377	2.377
10/12 SLU 289	2.877	1.877	1.877	2.877

Ordering information for frame and companion insert molds can be found in the front of this section.



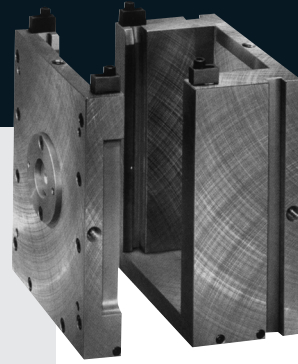

Frame

ITEM NO.
10/14 UF 321

Companion Interchangeable Insert Molds

- ❶ Frame clamps at this end of insert mold and ejector plates are flush with this end of insert.
- ❷ Support post not supplied. Grind +.001 to +.002 higher than height of ejection (see page C 131).
- ❸ Thicker plate optional (quotation on request).
- ❹ 3/4 x 5° lead this end.

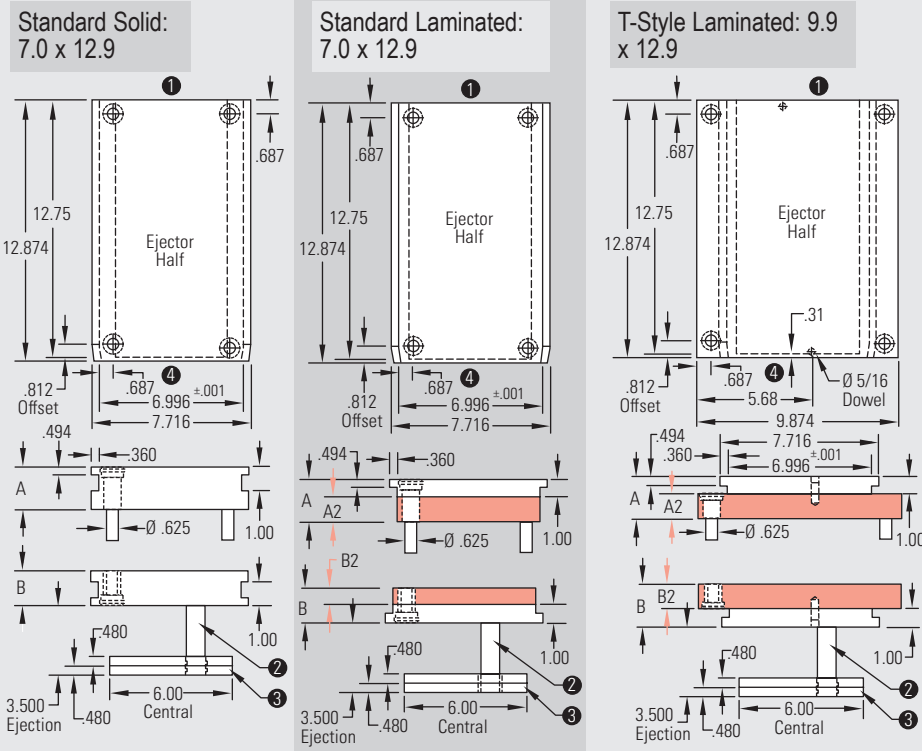

UF 321 Frame Upper – Side View

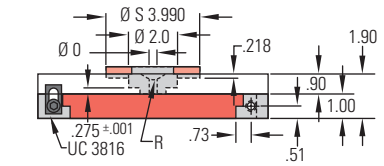

UF 321 Frame Upper – Top View

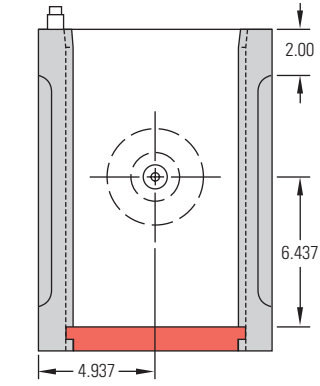

UF 321 Frame Lower – Side View

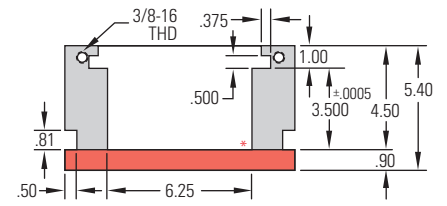

* Taper slot to accommodate sleeve ejection optional (quotation on request).

UF 321 Frame Lower – Top View

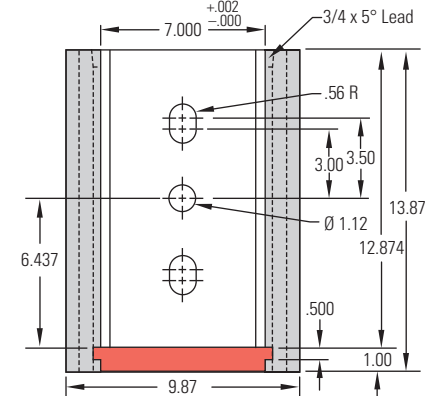

Frame supplied with or without sprue bushing

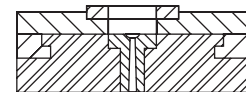

Standard Solid Construction

ITEM NO.	A	B
10/14 SSU 221	1.377	1.377
10/14 SSU 222	1.377	1.877
10/14 SSU 223	1.877	1.377
10/14 SSU 224	1.877	1.877
10/14 SSU 225	1.877	2.377
10/14 SSU 226	2.377	1.877
10/14 SSU 227	2.377	2.377
10/14 SSU 228	2.377	2.877
10/14 SSU 229	2.877	2.377
10/14 SSU 230	2.877	2.877

T-Style Laminated Construction

ITEM NO.	A	A2	B2	B
10/14 TLU 201	1.877	0.877	0.877	1.877
10/14 TLU 202	1.877	0.877	1.377	2.377
10/14 TLU 203	2.377	1.377	0.877	1.877
10/14 TLU 204	2.377	1.377	1.377	2.377
10/14 TLU 205	2.377	1.377	1.877	2.877
10/14 TLU 206	2.877	1.877	1.377	2.377
10/14 TLU 207	2.877	1.877	1.877	2.877
10/14 TLU 208	2.877	1.877	2.377	3.377
10/14 TLU 209	3.377	2.377	1.877	2.877
10/14 TLU 210	3.377	2.377	2.377	3.377

Standard Laminated Construction

ITEM NO.	A	A2	B2	B
10/14 SLU 281	1.877	0.877	0.877	1.877
10/14 SLU 282	1.877	0.877	1.377	2.377
10/14 SLU 283	1.877	0.877	1.877	2.877
10/14 SLU 284	2.377	1.377	0.877	1.877
10/14 SLU 285	2.377	1.377	1.377	2.377
10/14 SLU 286	2.377	1.377	1.877	2.877
10/14 SLU 287	2.877	1.877	0.877	1.877
10/14 SLU 288	2.877	1.877	1.377	2.377
10/14 SLU 289	2.877	1.877	1.877	2.877

Ordering information for frame and companion insert molds can be found in the front of this section.

MUD® Quick-Change Mold Frames & Inserts for U-Style | 10/14 UF 321



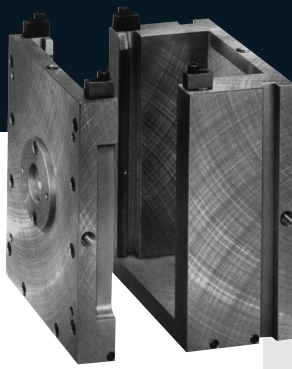

UF Quick-Change U-Style Frame & Companion Insert Molds

Frame

ITEM
NO.

10/16 UF 321

UF 321 Frame Upper – Side View

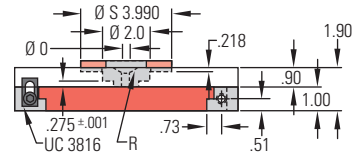

UF 321 Frame Upper – Top View

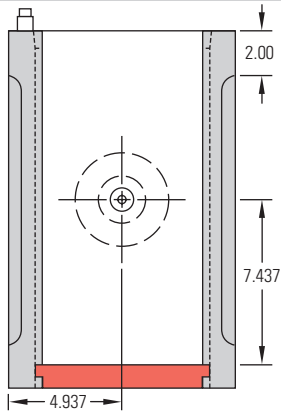

UF 321 Frame Lower – Side View

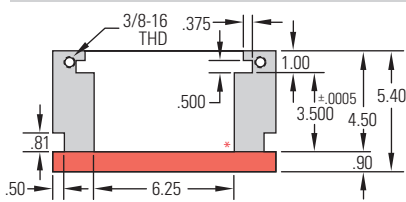

UF 321 Frame Lower – Top View

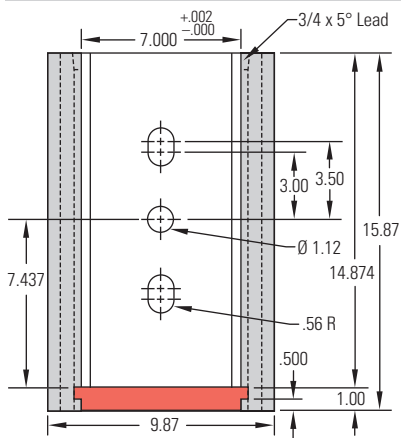

Frame supplied with or without sprue bushing

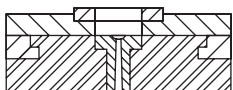

Companion Interchangeable Insert Molds

- 1 Frame clamps at this end of insert mold and ejector plates are flush with this end of insert.
- 2 Support post not supplied. Grind $+.001$ to $+.002$ higher than height of ejection (see page C 131).
- 3 Thicker plate optional (quotation on request).
- 4 $3/4 \times 5^\circ$ lead this end.

Standard Solid:
7.0 x 14.9

Standard Laminated:
7.0 x 14.9

T-Style Laminated: 9.9
x 14.9

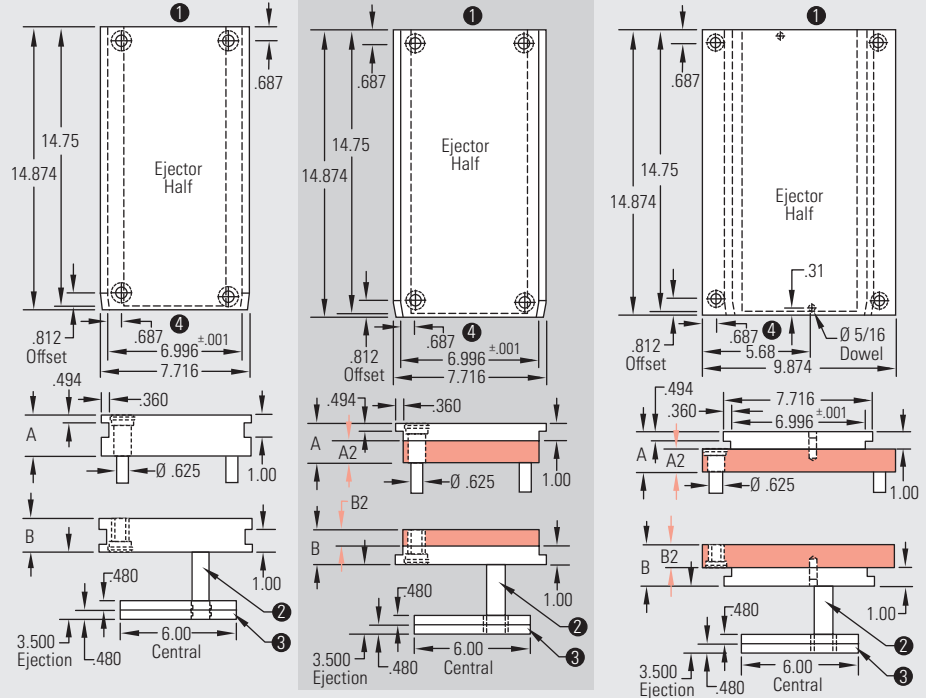

Standard Solid Construction

ITEM NO.	A	B
10/16 SSU 221	1.377	1.377
10/16 SSU 222	1.377	1.877
10/16 SSU 223	1.877	1.377
10/16 SSU 224	1.877	1.877
10/16 SSU 225	1.877	2.377
10/16 SSU 226	2.377	1.877
10/16 SSU 227	2.377	2.377
10/16 SSU 228	2.377	2.877
10/16 SSU 229	2.877	2.377
10/16 SSU 230	2.877	2.877

T-Style Laminated Construction

ITEM NO.	A	A2	B2	B
10/16 TLU 201	1.877	0.877	0.877	1.877
10/16 TLU 202	1.877	0.877	1.377	2.377
10/16 TLU 203	2.377	1.377	0.877	1.877
10/16 TLU 204	2.377	1.377	1.377	2.377
10/16 TLU 205	2.377	1.377	1.877	2.877
10/16 TLU 206	2.877	1.877	1.377	2.377
10/16 TLU 207	2.877	1.877	1.877	2.877
10/16 TLU 208	2.877	1.877	2.377	3.377
10/16 TLU 209	3.377	2.377	1.877	2.877
10/16 TLU 210	3.377	2.377	2.377	3.377

Standard Laminated Construction

ITEM NO.	A	A2	B2	B
10/16 SLU 281	1.877	0.877	0.877	1.877
10/16 SLU 282	1.877	0.877	1.377	2.377
10/16 SLU 283	1.877	0.877	1.877	2.877
10/16 SLU 284	2.377	1.377	0.877	1.877
10/16 SLU 285	2.377	1.377	1.377	2.377
10/16 SLU 286	2.377	1.377	1.877	2.877
10/16 SLU 287	2.877	1.877	0.877	1.877
10/16 SLU 288	2.877	1.877	1.377	2.377
10/16 SLU 289	2.877	1.877	1.877	2.877

Ordering information for frame and companion insert molds can be found in the front of this section.



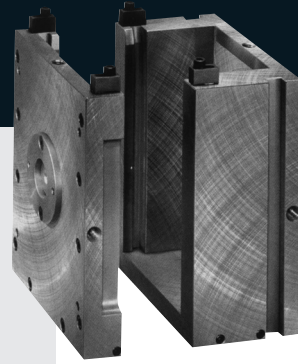

Frame

ITEM NO.
11/11 UF 321

Companion Interchangeable Insert Molds

- 1 Frame clamps at this end of insert mold and ejector plates are flush with this end of insert.
- 2 Support post not supplied. Grind +.001 to +.002 higher than height of ejection (see page C 131).
- 3 Thicker plate optional (quotation on request).
- 4 3/4 x 5° lead this end.

Standard Solid:
8.0 x 10.0

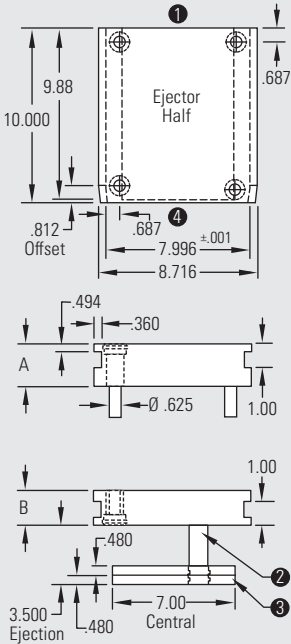

Standard Laminated:
8.0 x 10.0

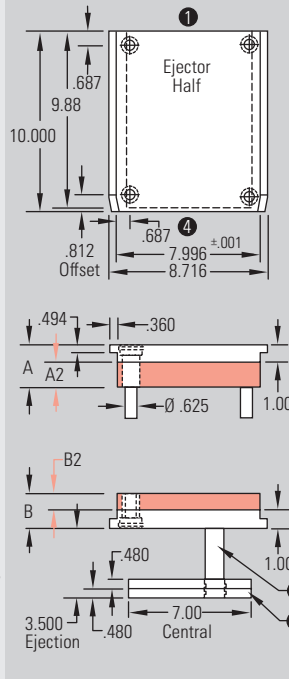

T-Style Laminated: 11.5
x 11.0

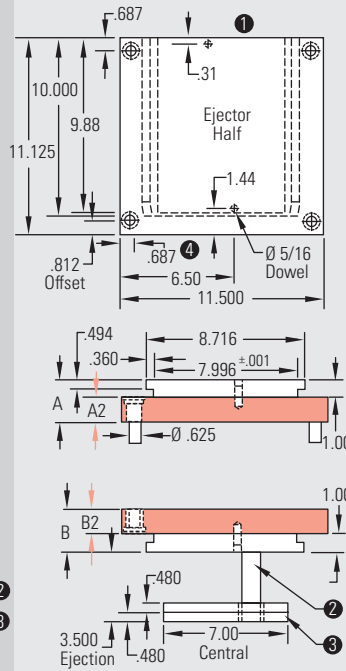

Standard Solid Construction

ITEM NO.	A	B
11/11 SSU 221	1.377	1.377
11/11 SSU 222	1.377	1.877
11/11 SSU 223	1.877	1.377
11/11 SSU 224	1.877	1.877
11/11 SSU 225	1.877	2.377
11/11 SSU 226	2.377	1.877
11/11 SSU 227	2.377	2.377
11/11 SSU 228	2.377	2.877
11/11 SSU 229	2.877	2.377
11/11 SSU 230	2.877	2.877

T-Style Laminated Construction

ITEM NO.	A	A2	B2	B
11/11 TLU 201	1.877	0.877	0.877	1.877
11/11 TLU 202	1.877	0.877	1.377	2.377
11/11 TLU 203	2.377	1.377	0.877	1.877
11/11 TLU 204	2.377	1.377	1.377	2.377
11/11 TLU 205	2.377	1.377	1.877	2.877
11/11 TLU 206	2.877	1.877	1.377	2.377
11/11 TLU 207	2.877	1.877	1.877	2.877
11/11 TLU 208	2.877	1.877	2.377	3.377
11/11 TLU 209	3.377	2.377	1.877	2.877
11/11 TLU 210	3.377	2.377	2.377	3.377

Standard Laminated Construction

ITEM NO.	A	A2	B2	B
11/11 SLU 281	1.877	0.877	0.877	1.877
11/11 SLU 282	1.877	0.877	1.377	2.377
11/11 SLU 283	1.877	0.877	1.877	2.877
11/11 SLU 284	2.377	1.377	0.877	1.877
11/11 SLU 285	2.377	1.377	1.377	2.377
11/11 SLU 286	2.377	1.377	1.877	2.877
11/11 SLU 287	2.877	1.877	0.877	1.877
11/11 SLU 288	2.877	1.877	1.377	2.377
11/11 SLU 289	2.877	1.877	1.877	2.877

Ordering information for frame and companion insert molds can be found in the front of this section.

UF 321 Frame Upper – Side View

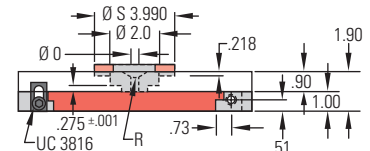

UF 321 Frame Upper – Top View

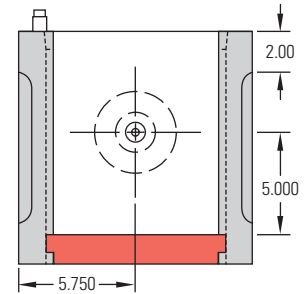

UF 321 Frame Lower – Side View

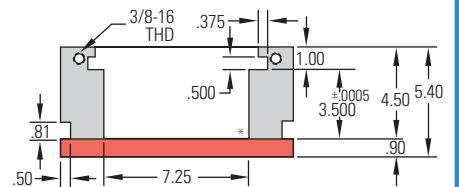

* Taper slot to accommodate sleeve ejection optional (quotation on request).

UF 321 Frame Lower – Top View

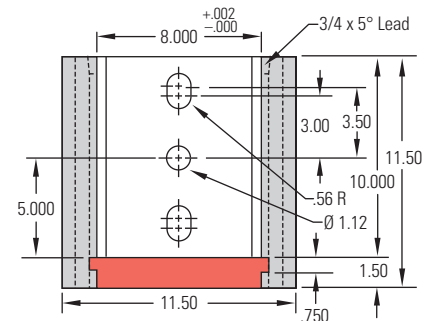

Frame supplied with or without sprue bushing

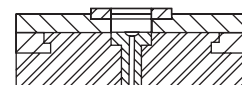

MUD® Quick-Change Mold Frames & Inserts for U-Style | 11/11 UF 321



UF Quick-Change U-Style Shuttle Frame & Companion Insert Molds

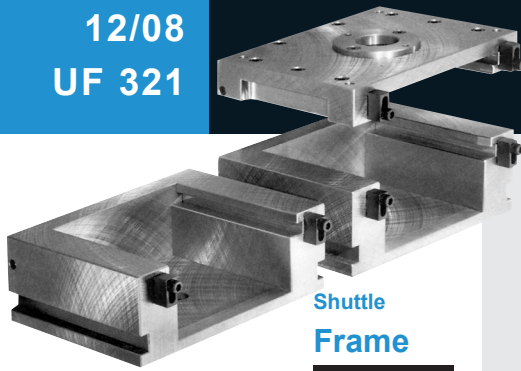

Shuttle
Frame

ITEM NO.

12/08 UF 321

UF 321 Frame Upper – Side View

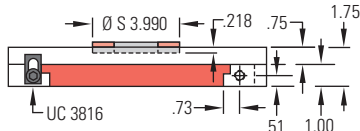

“S” diameter of locating ring supplied standard 3.990 (other sizes available on request).

UF 321 Frame Upper – Top View

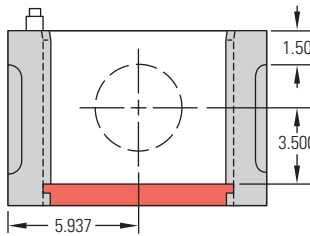

Cavity half, one (1) required.

UF 321 Frame Lower – Side View

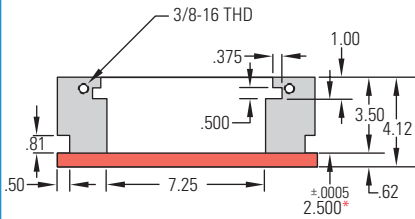

* Height of ejection can be modified to suit nozzle height of machine (quotation on request).

UF 321 Frame Lower – Top View

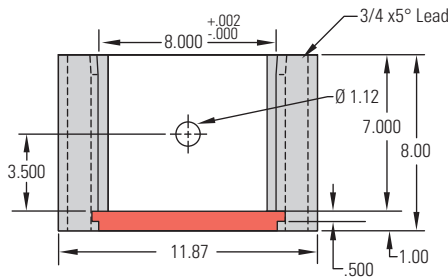

Ejector half, two (2) required.

NOTE: Insert molds can be ordered with two (2) “B” halves by noting “S” after catalog code number.

Companion Interchangeable Insert Molds

- 1 Frame clamps at this end of insert mold and ejector plates are flush with this end of insert.
- 2 Support post not supplied. Grind $+.001$ to $+.002$ higher than height of ejection (see page C 131).
- 3 Thicker plate optional (quotation on request).
- 4 $3/4 \times 5^\circ$ lead this end.

Standard Solid:
8.0 x 8.0

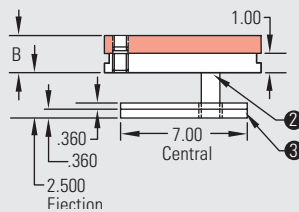
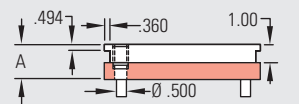
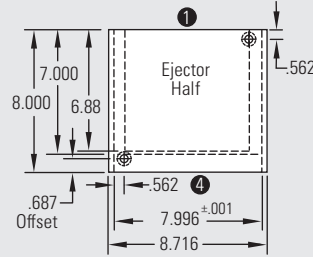

T-Style Laminated:
11.9 x 8.0

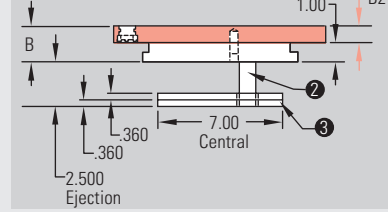
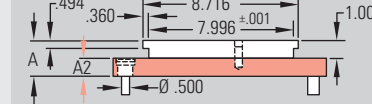
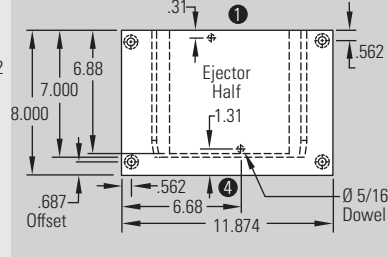

Optional

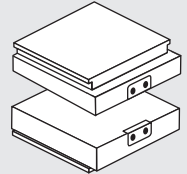

Hardened runner pads available (quotation on request).

Standard Solid Construction

ITEM NO.	A	A2	B2	B
12/08 SSU 221	2.877	1.877	1.877	2.877

T-Style Laminated Construction

ITEM NO.	A	A2	B2	B
12/08 TLU 201	2.877	1.877	1.877	2.877

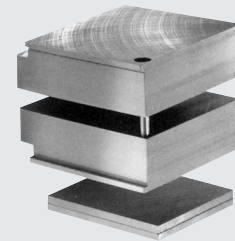

Ordering information for frame and companion insert molds can be found in the front of this section.

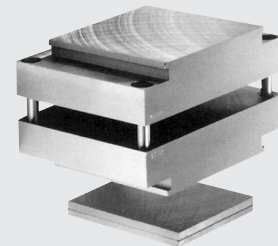

UF Quick-Change U-Style Frame & Companion Insert Molds

12/14
UF 321

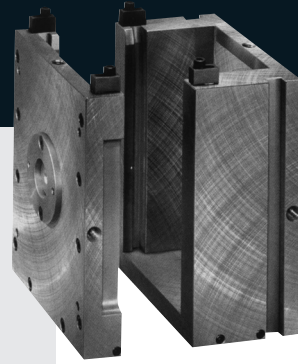

Frame

ITEM NO.
12/14 UF 321

Companion Interchangeable Insert Molds

- 1 Frame clamps at this end of insert mold and ejector plates are flush with this end of insert.
- 2 Support post not supplied. Grind +.001 to +.002 higher than height of ejection (see page C 131).
- 3 Thicker plate optional (quotation on request).
- 4 3/4 x 5° lead this end.

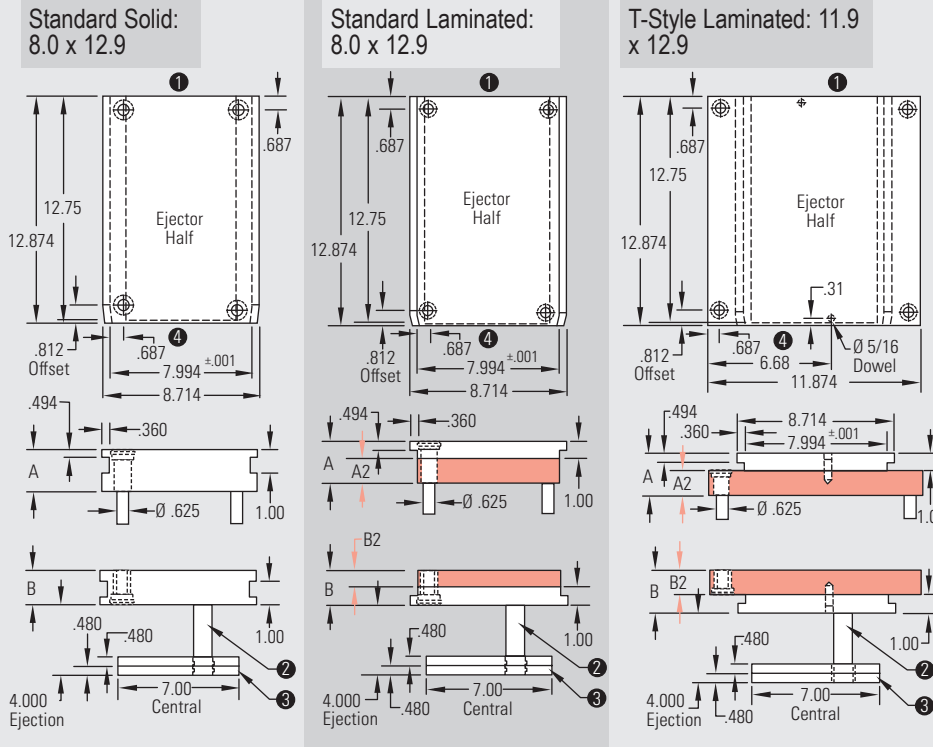

UF 321 Frame Upper – Side View

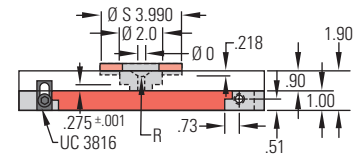

UF 321 Frame Upper – Top View

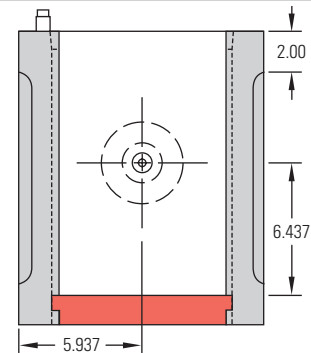

UF 321 Frame Lower – Side View

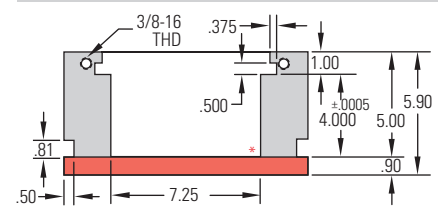

* Taper slot to accommodate sleeve ejection optional (quotation on request).

UF 321 Frame Lower – Top View

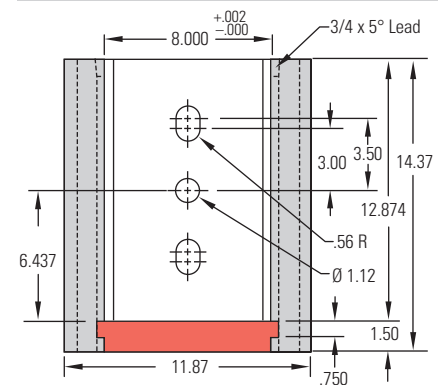

Frame supplied with or without sprue bushing



Standard Solid Construction

ITEM NO.	A	B
12/14 SSU 221	1.377	1.377
12/14 SSU 222	1.377	1.877
12/14 SSU 223	1.377	2.377
12/14 SSU 224	1.877	1.377
12/14 SSU 225	1.877	1.877
12/14 SSU 226	1.877	2.377
12/14 SSU 227	1.877	2.877
12/14 SSU 228	2.377	1.377
12/14 SSU 229	2.377	1.877
12/14 SSU 230	2.377	2.377
12/14 SSU 231	2.377	2.877
12/14 SSU 232	2.877	1.877
12/14 SSU 233	2.877	2.377
12/14 SSU 234	2.877	2.877

T-Style Laminated Construction

ITEM NO.	A	A2	B2	B
12/14 TLU 201	2.377	1.377	1.377	2.377
12/14 TLU 202	2.377	1.377	1.877	2.877
12/14 TLU 203	2.377	1.377	2.377	3.377
12/14 TLU 204	2.877	1.877	1.377	2.377
12/14 TLU 205	2.877	1.877	1.877	2.877
12/14 TLU 206	2.877	1.877	2.377	3.377
12/14 TLU 207	2.877	1.877	2.877	3.877
12/14 TLU 208	3.377	2.377	1.377	2.377
12/14 TLU 209	3.377	2.377	1.877	2.877
12/14 TLU 210	3.377	2.377	2.377	3.377
12/14 TLU 211	3.377	2.377	2.877	3.877
12/14 TLU 212	3.877	2.877	1.877	2.877
12/14 TLU 213	3.877	2.877	2.377	3.377
12/14 TLU 214	3.877	2.877	2.877	3.877

Standard Laminated Construction

ITEM NO.	A	A2	B2	B
12/14 SLU 281	1.877	0.877	0.877	1.877
12/14 SLU 282	1.877	0.877	1.377	2.377
12/14 SLU 283	1.877	0.877	1.877	2.877
12/14 SLU 284	2.377	1.377	0.877	1.877
12/14 SLU 285	2.377	1.377	1.377	2.377
12/14 SLU 286	2.377	1.377	1.877	2.877
12/14 SLU 287	2.377	1.377	2.377	3.377
12/14 SLU 288	2.877	1.877	0.877	1.877
12/14 SLU 289	2.877	1.877	1.377	2.377
12/14 SLU 290	2.877	1.877	1.877	2.877
12/14 SLU 291	2.877	1.877	2.377	3.377
12/14 SLU 292	3.377	2.377	1.377	2.377
12/14 SLU 293	3.377	2.377	1.877	2.877
12/14 SLU 294	3.377	2.377	2.377	3.377

Ordering information for frame and companion insert molds can be found in the front of this section.

MUD® Quick-Change Mold Frames & Inserts for U-Style | 12/14 UF 321



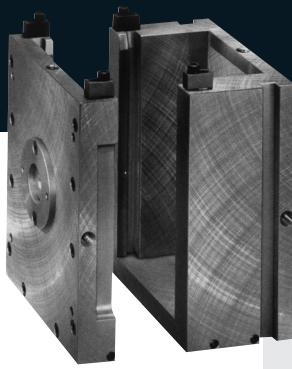

UF Quick-Change U-Style Frame & Companion Insert Molds

Frame

ITEM NO.
12/16 UF 321

Companion Interchangeable Insert Molds

- 1 Frame clamps at this end of insert mold and ejector plates are flush with this end of insert.
- 2 Support post not supplied. Grind +.001 to +.002 higher than height of ejection (see page C 131).
- 3 Thicker plate optional (quotation on request).
- 4 3/4 x 5° lead this end.

Standard Solid:
8.0 x 14.9

Standard Laminated:
8.0 x 14.9

T-Style Laminated: 11.9
x 14.9

UF 321 Frame Upper – Side View

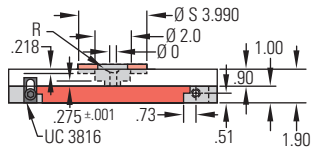

UF 321 Frame Upper – Top View

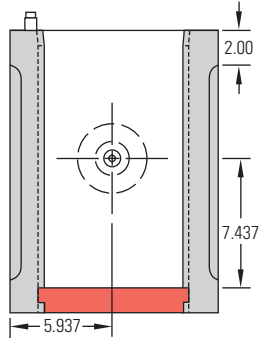

UF 321 Frame Lower – Side View

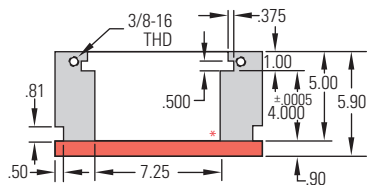

* Taper slot to accommodate sleeve ejection optional (quotation on request).

UF 321 Frame Lower – Top View

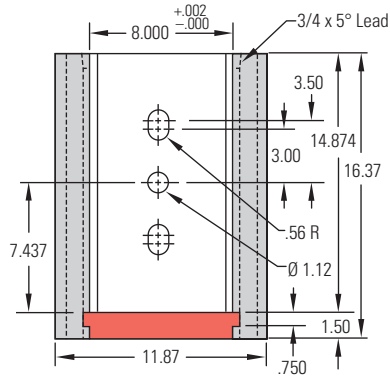

Frame supplied with or without sprue bushing

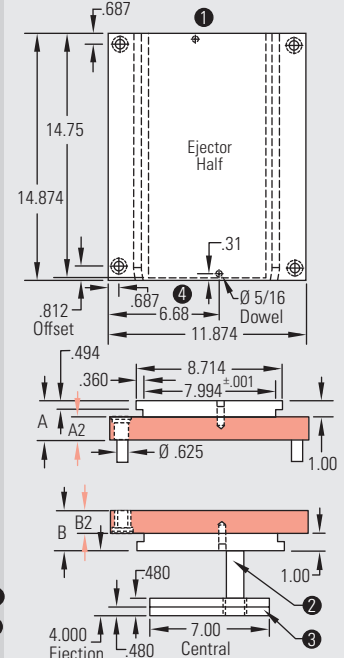
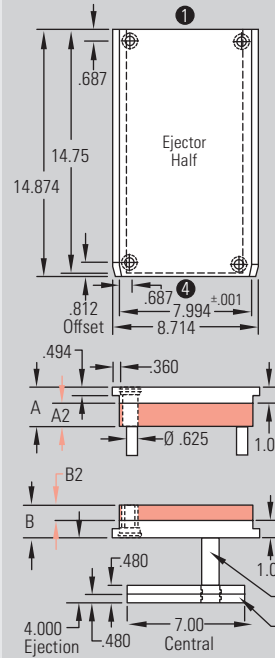
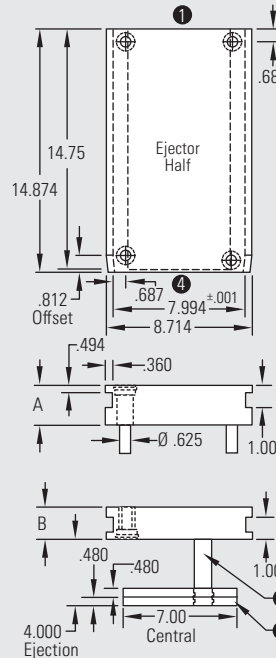

Standard Solid Construction

ITEM NO.	A	B
12/16 SSU 221	1.377	1.377
12/16 SSU 222	1.377	1.877
12/16 SSU 223	1.377	2.377
12/16 SSU 224	1.877	1.377
12/16 SSU 225	1.877	1.877
12/16 SSU 226	1.877	2.377
12/16 SSU 227	1.877	2.877
12/16 SSU 228	2.377	1.377
12/16 SSU 229	2.377	1.877
12/16 SSU 230	2.377	2.377
12/16 SSU 231	2.377	2.877
12/16 SSU 232	2.877	1.877
12/16 SSU 233	2.877	2.377
12/16 SSU 234	2.877	2.877

Standard Laminated Construction

ITEM NO.	A	A2	B2	B
12/16 SLU 281	1.877	0.877	0.877	1.877
12/16 SLU 282	1.877	0.877	1.377	2.377
12/16 SLU 283	1.877	0.877	1.877	2.877
12/16 SLU 284	2.377	1.377	0.877	1.877
12/16 SLU 285	2.377	1.377	1.377	2.377
12/16 SLU 286	2.377	1.377	1.877	2.877
12/16 SLU 287	2.377	1.377	2.377	3.377
12/16 SLU 288	2.877	1.877	0.877	1.877
12/16 SLU 289	2.877	1.877	1.377	2.377
12/16 SLU 290	2.877	1.877	1.877	2.877
12/16 SLU 291	2.877	1.877	2.377	3.377
12/16 SLU 292	3.377	2.377	1.377	2.377
12/16 SLU 293	3.377	2.377	1.877	2.877
12/16 SLU 294	3.377	2.377	2.377	3.377

T-Style Laminated Construction

ITEM NO.	A	A2	B2	B
12/16 TLU 201	2.377	1.377	1.377	2.377
12/16 TLU 202	2.377	1.377	1.877	2.877
12/16 TLU 203	2.377	1.377	2.377	3.377
12/16 TLU 204	2.877	1.877	1.377	2.377
12/16 TLU 205	2.877	1.877	1.877	2.877
12/16 TLU 206	2.877	1.877	2.377	3.377
12/16 TLU 207	2.877	1.877	2.877	3.877
12/16 TLU 208	3.377	2.377	1.377	2.377
12/16 TLU 209	3.377	2.377	1.877	2.877
12/16 TLU 210	3.377	2.377	2.377	3.377
12/16 TLU 211	3.377	2.377	2.877	3.877
12/16 TLU 212	3.877	2.877	1.877	2.877
12/16 TLU 213	3.877	2.877	2.377	3.377
12/16 TLU 214	3.877	2.877	2.877	3.877

Ordering information for frame and companion insert molds can be found in the front of this section.



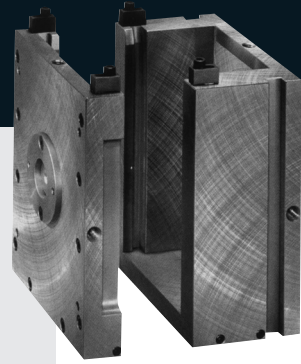

Frame

ITEM NO.

12/18 UF 321

Companion Interchangeable Insert Molds

- 1 Frame clamps at this end of insert mold and ejector plates are flush with this end of insert.
- 2 Support post not supplied. Grind +.001 to +.002 higher than height of ejection (see page C 131).
- 3 Thicker plate optional (quotation on request).
- 4 3/4 x 5° lead this end.

**Standard Solid:
8.0 x 16.9**

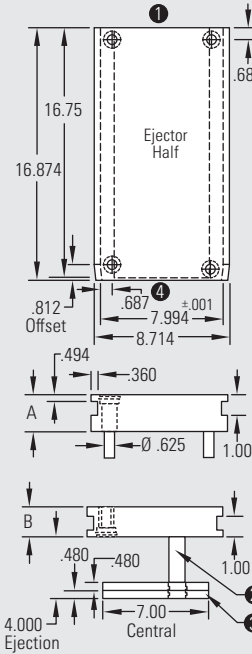

**Standard Laminated:
8.0 x 16.9**

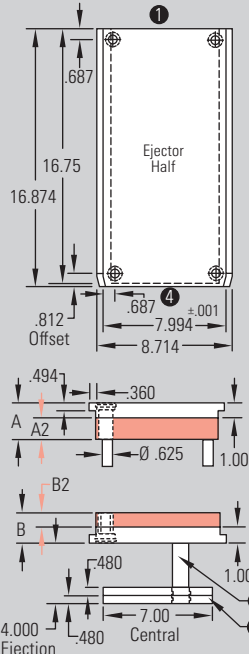

**T-Style Laminated: 11.9
x 16.9**

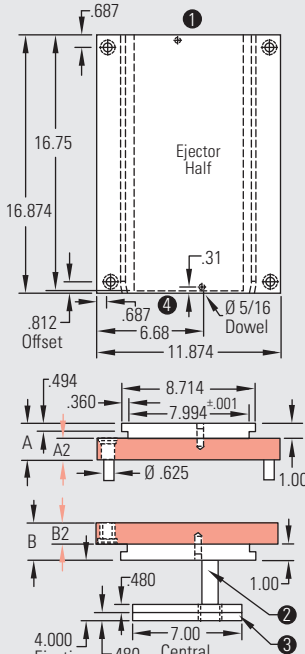

UF 321 Frame Upper – Side View

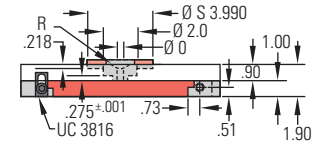

UF 321 Frame Upper – Top View

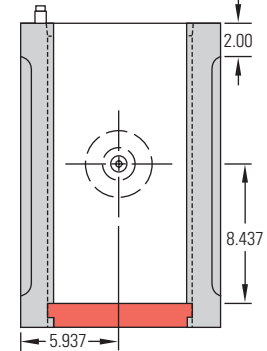

UF 321 Frame Lower – Side View

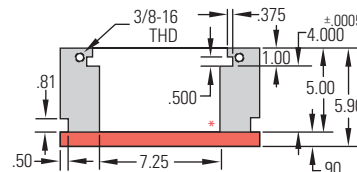

* Taper slot to accommodate sleeve ejection optional (quotation on request).

UF 321 Frame Lower – Top View

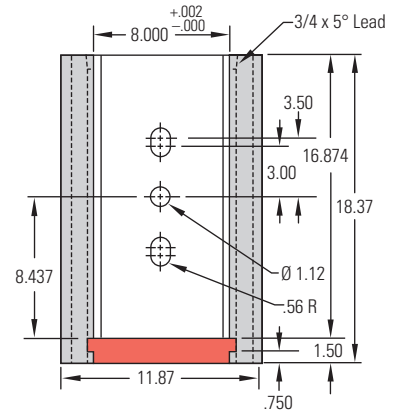

Frame supplied with or without sprue bushing



Standard Solid Construction

ITEM NO.	A	B
12/18 SSU 221	1.377	1.377
12/18 SSU 222	1.377	1.877
12/18 SSU 223	1.377	2.377
12/18 SSU 224	1.877	1.377
12/18 SSU 225	1.877	1.877
12/18 SSU 226	1.877	2.377
12/18 SSU 227	1.877	2.877
12/18 SSU 228	2.377	1.377
12/18 SSU 229	2.377	1.877
12/18 SSU 230	2.377	2.377
12/18 SSU 231	2.377	2.877
12/18 SSU 232	2.877	1.877
12/18 SSU 233	2.877	2.377
12/18 SSU 234	2.877	2.877

T-Style Laminated Construction

ITEM NO.	A	A2	B2	B
12/18 TLU 201	2.377	1.377	1.377	2.377
12/18 TLU 202	2.377	1.377	1.877	2.877
12/18 TLU 203	2.377	1.377	2.377	3.377
12/18 TLU 204	2.877	1.877	1.377	2.377
12/18 TLU 205	2.877	1.877	1.877	2.877
12/18 TLU 206	2.877	1.877	2.377	3.377
12/18 TLU 207	2.877	1.877	2.877	3.877
12/18 TLU 208	3.377	2.377	1.377	2.377
12/18 TLU 209	3.377	2.377	1.877	2.877
12/18 TLU 210	3.377	2.377	2.377	3.377
12/18 TLU 211	3.377	2.377	2.877	3.877
12/18 TLU 212	3.877	2.877	1.877	2.877
12/18 TLU 213	3.877	2.877	2.377	3.377
12/18 TLU 214	3.877	2.877	2.877	3.877

Standard Laminated Construction

ITEM NO.	A	A2	B2	B
12/18 SLU 281	1.877	0.877	0.877	1.877
12/18 SLU 282	1.877	0.877	1.377	2.377
12/18 SLU 283	1.877	0.877	1.877	2.877
12/18 SLU 284	2.377	1.377	0.877	1.877
12/18 SLU 285	2.377	1.377	1.377	2.377
12/18 SLU 286	2.377	1.377	1.877	2.877
12/18 SLU 287	2.377	1.377	2.377	3.377
12/18 SLU 288	2.877	1.877	0.877	1.877
12/18 SLU 289	2.877	1.877	1.377	2.377
12/18 SLU 290	2.877	1.877	1.877	2.877
12/18 SLU 291	2.877	1.877	2.377	3.377
12/18 SLU 292	3.377	2.377	1.377	2.377
12/18 SLU 293	3.377	2.377	1.877	2.877
12/18 SLU 294	3.377	2.377	2.377	3.377

Ordering information for frame and companion insert molds can be found in the front of this section.



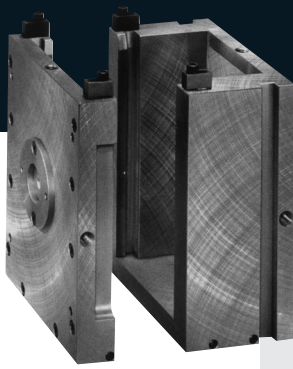

UF Quick-Change U-Style Frame & Companion Insert Molds

Frame

ITEM
NO.

12/20 UF 321

Companion Interchangeable Insert Molds

- 1 Frame clamps at this end of insert mold and ejector plates are flush with this end of insert.
- 2 Support post not supplied. Grind $+0.001$ to $+0.002$ higher than height of ejection (see page C 131).
- 3 Thicker plate optional (quotation on request).
- 4 $3/4 \times 5^\circ$ lead this end.

Standard Solid:
8.0 x 18.9

Standard Laminated:
8.0 x 18.9

T-Style Laminated: 11.9
x 18.9

UF 321 Frame Upper – Side View

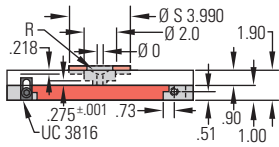

UF 321 Frame Upper – Top View

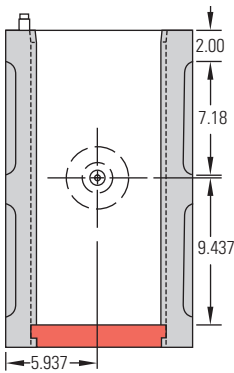

UF 321 Frame Lower – Side View

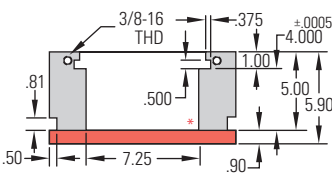

* Taper slot to accommodate sleeve ejection optional (quotation on request).

UF 321 Frame Lower – Top View

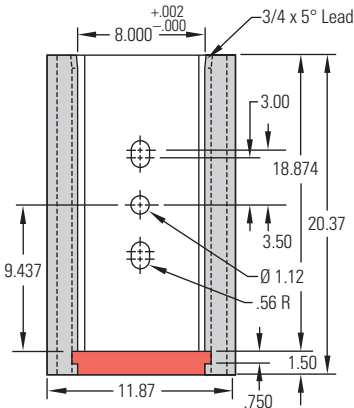

Frame supplied with or without sprue bushing

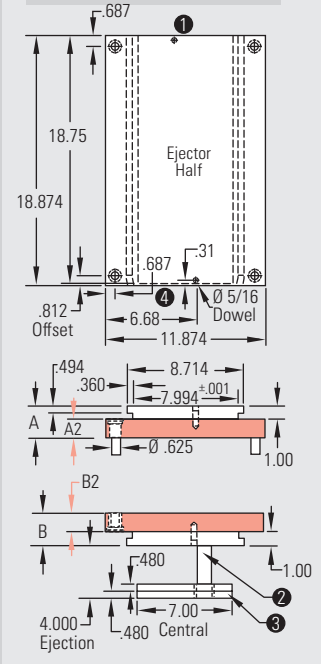
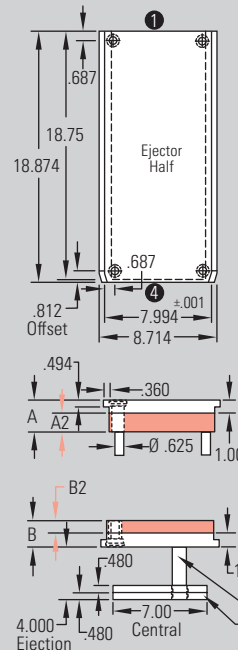
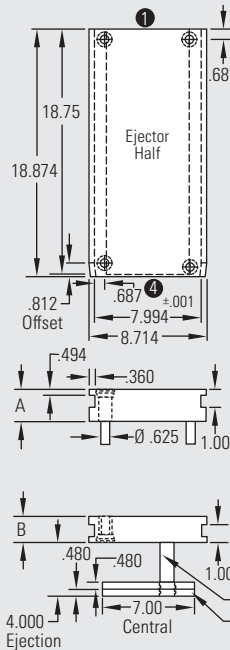

Standard Solid Construction

ITEM NO.	A	B
12/20 SSU 221	1.377	1.377
12/20 SSU 222	1.377	1.877
12/20 SSU 223	1.377	2.377
12/20 SSU 224	1.877	1.377
12/20 SSU 225	1.877	1.877
12/20 SSU 226	1.877	2.377
12/20 SSU 227	1.877	2.877
12/20 SSU 228	2.377	1.377
12/20 SSU 229	2.377	1.877
12/20 SSU 230	2.377	2.377
12/20 SSU 231	2.377	2.877
12/20 SSU 232	2.877	1.877
12/20 SSU 233	2.877	2.377
12/20 SSU 234	2.877	2.877

T-Style Laminated Construction

ITEM NO.	A	A2	B2	B
12/20 TLU 201	2.377	1.377	1.377	2.377
12/20 TLU 202	2.377	1.377	1.877	2.877
12/20 TLU 203	2.377	1.377	2.377	3.377
12/20 TLU 204	2.877	1.877	1.377	2.377
12/20 TLU 205	2.877	1.877	1.877	2.877
12/20 TLU 206	2.877	1.877	2.377	3.377
12/20 TLU 207	2.877	1.877	2.877	3.877
12/20 TLU 208	3.377	2.377	1.377	2.377
12/20 TLU 209	3.377	2.377	1.877	2.877
12/20 TLU 210	3.377	2.377	2.377	3.377
12/20 TLU 211	3.377	2.377	2.877	3.877
12/20 TLU 212	3.877	2.877	1.877	2.877
12/20 TLU 213	3.877	2.877	2.377	3.377
12/20 TLU 214	3.877	2.877	2.877	3.877

Standard Laminated Construction

ITEM NO.	A	A2	B2	B
12/20 SLU 281	1.877	0.877	0.877	1.877
12/20 SLU 282	1.877	0.877	1.377	2.377
12/20 SLU 283	1.877	0.877	1.877	2.877
12/20 SLU 284	2.377	1.377	0.877	1.877
12/20 SLU 285	2.377	1.377	1.377	2.377
12/20 SLU 286	2.377	1.377	1.877	2.877
12/20 SLU 287	2.377	1.377	2.377	3.377
12/20 SLU 288	2.877	1.877	0.877	1.877
12/20 SLU 289	2.877	1.877	1.377	2.377
12/20 SLU 290	2.877	1.877	1.877	2.877
12/20 SLU 291	2.877	1.877	2.377	3.377
12/20 SLU 292	3.377	2.377	1.377	2.377
12/20 SLU 293	3.377	2.377	1.877	2.877
12/20 SLU 294	3.377	2.377	2.377	3.377

Ordering information for frame and companion insert molds can be found in the front of this section.



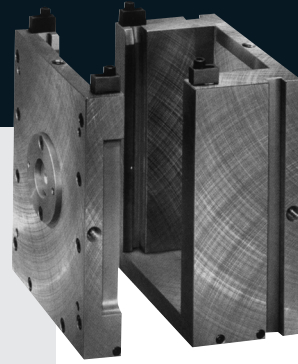

Frame

ITEM NO.

13/16 UF 321

Companion Interchangeable Insert Molds

- 1 Frame clamps at this end of insert mold and ejector plates are flush with this end of insert.
- 2 Support post not supplied. Grind +.001 to +.002 higher than height of ejection (see page C 131).
- 3 Thicker plate optional (quotation on request).
- 4 3/4 x 5° lead this end.

Standard Solid:
9.0 x 14.9

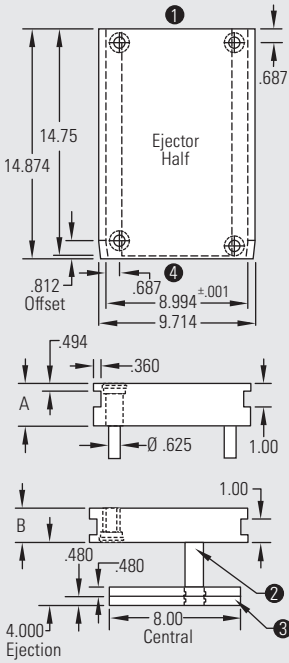

Standard Laminated:
9.0 x 14.9

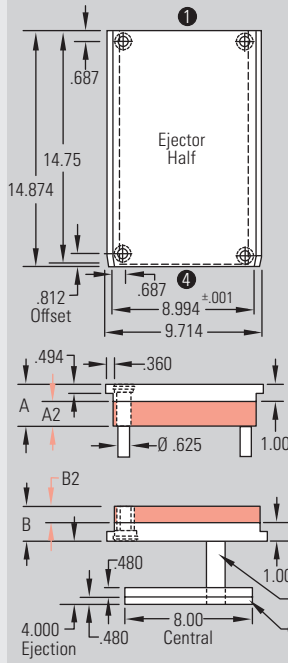

T-Style Laminated: 12.9
x 14.9

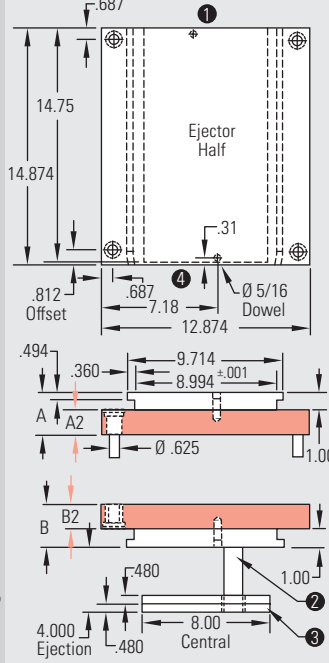

UF 321 Frame Upper – Side View

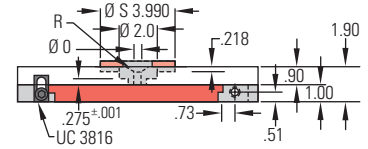

UF 321 Frame Upper – Top View

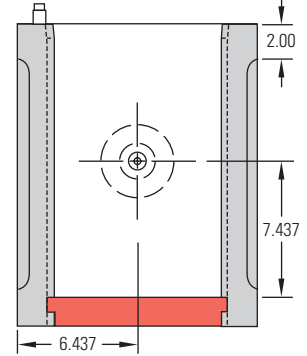

UF 321 Frame Lower – Side View

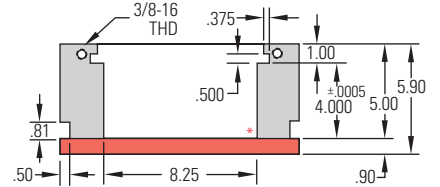

* Taper slot to accommodate sleeve ejection optional (quotation on request).

UF 321 Frame Lower – Top View

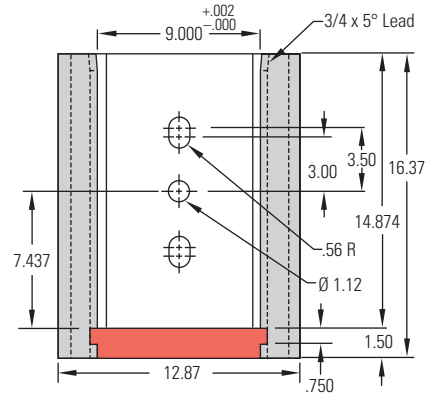

Frame supplied with or without sprue bushing



Standard Solid Construction

ITEM NO.	A	B
13/16 SSU 221	1.377	1.377
13/16 SSU 222	1.377	1.877
13/16 SSU 223	1.377	2.377
13/16 SSU 224	1.877	1.377
13/16 SSU 225	1.877	1.877
13/16 SSU 226	1.877	2.377
13/16 SSU 227	1.877	2.877
13/16 SSU 228	2.377	1.377
13/16 SSU 229	2.377	1.877
13/16 SSU 230	2.377	2.377
13/16 SSU 231	2.377	2.877
13/16 SSU 232	2.877	1.877
13/16 SSU 233	2.877	2.377
13/16 SSU 234	2.877	2.877

T-Style Laminated Construction

ITEM NO.	A	A2	B2	B
13/16 TLU 201	2.377	1.377	1.377	2.377
13/16 TLU 202	2.377	1.377	1.877	2.877
13/16 TLU 203	2.377	1.377	2.377	3.377
13/16 TLU 204	2.877	1.877	1.377	2.377
13/16 TLU 205	2.877	1.877	1.877	2.877
13/16 TLU 206	2.877	1.877	2.377	3.377
13/16 TLU 207	2.877	1.877	2.877	3.877
13/16 TLU 208	3.377	2.377	1.377	2.377
13/16 TLU 209	3.377	2.377	1.877	2.877
13/16 TLU 210	3.377	2.377	2.377	3.377
13/16 TLU 211	3.377	2.377	2.877	3.877
13/16 TLU 212	3.877	2.877	1.877	2.877
13/16 TLU 213	3.877	2.877	2.377	3.377
13/16 TLU 214	3.877	2.877	2.877	3.877

Standard Laminated Construction

ITEM NO.	A	A2	B2	B
13/16 SLU 281	1.877	0.877	0.877	1.877
13/16 SLU 282	1.877	0.877	1.377	2.377
13/16 SLU 283	1.877	0.877	1.877	2.877
13/16 SLU 284	2.377	1.377	0.877	1.877
13/16 SLU 285	2.377	1.377	1.377	2.377
13/16 SLU 286	2.377	1.377	1.877	2.877
13/16 SLU 287	2.377	1.377	2.377	3.377
13/16 SLU 288	2.877	1.877	0.877	1.877
13/16 SLU 289	2.877	1.877	1.377	2.377
13/16 SLU 290	2.877	1.877	1.877	2.877
13/16 SLU 291	2.877	1.877	2.377	3.377
13/16 SLU 292	3.377	2.377	1.377	2.377
13/16 SLU 293	3.377	2.377	1.877	2.877
13/16 SLU 294	3.377	2.377	2.377	3.377

Ordering information for frame and companion insert molds can be found in the front of this section.



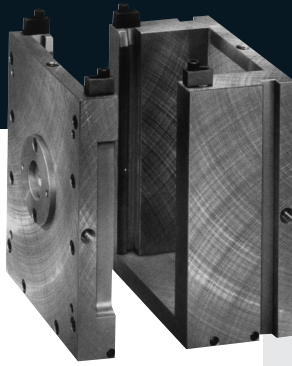

UF Quick-Change U-Style Frame & Companion Insert Molds

Frame

ITEM NO.
13/18 UF 321

UF 321 Frame Upper – Side View

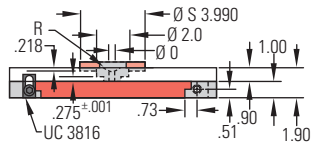

UF 321 Frame Upper – Top View

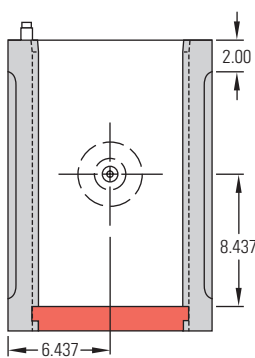

UF 321 Frame Lower – Side View

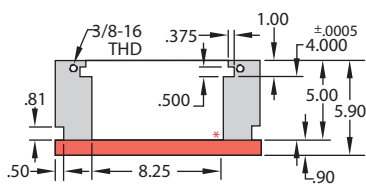

* Taper slot to accommodate sleeve ejection optional (quotation on request).

UF 321 Frame Lower – Top View

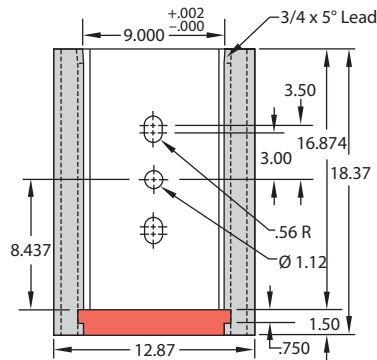

Frame supplied with or without sprue bushing



Companion Interchangeable Insert Molds

- 1 Frame clamps at this end of insert mold and ejector plates are flush with this end of insert.
- 2 Support post not supplied. Grind +.001 to +.002 higher than height of ejection (see page C 131).
- 3 Thicker plate optional (quotation on request).
- 4 3/4 x 5° lead this end.

Standard Solid:
9.0 x 16.9

Standard Laminated:
9.0 x 16.9

T-Style Laminated: 12.9
x 16.9

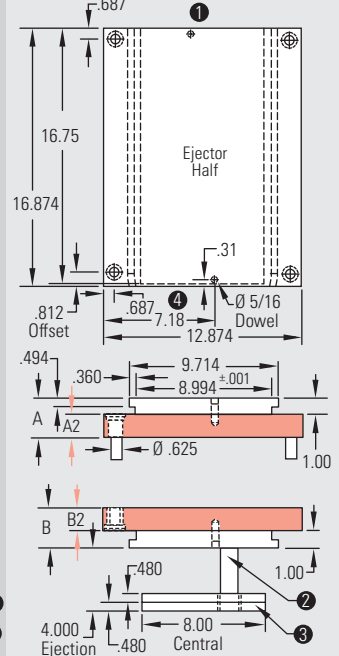
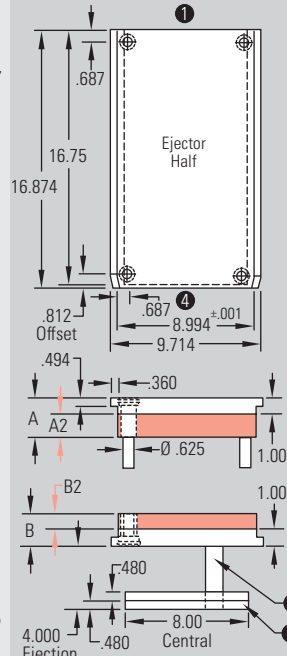
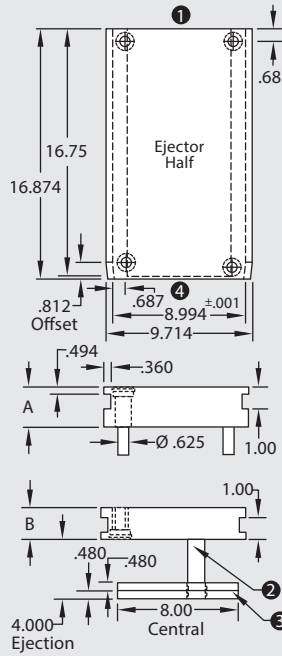

Standard Solid Construction

ITEM NO.	A	B
13/18 SSU 221	1.377	1.377
13/18 SSU 222	1.377	1.877
13/18 SSU 223	1.377	2.377
13/18 SSU 224	1.877	1.377
13/18 SSU 225	1.877	1.877
13/18 SSU 226	1.877	2.377
13/18 SSU 227	1.877	2.877
13/18 SSU 228	2.377	1.377
13/18 SSU 229	2.377	1.877
13/18 SSU 230	2.377	2.377
13/18 SSU 231	2.377	2.877
13/18 SSU 232	2.877	1.877
13/18 SSU 233	2.877	2.377
13/18 SSU 234	2.877	2.877

T-Style Laminated Construction

ITEM NO.	A	A2	B2	B
13/18 TLU 201	2.377	1.377	1.377	2.377
13/18 TLU 202	2.377	1.377	1.877	2.877
13/18 TLU 203	2.377	1.377	2.377	3.377
13/18 TLU 204	2.877	1.877	1.377	2.377
13/18 TLU 205	2.877	1.877	1.877	2.877
13/18 TLU 206	2.877	1.877	2.377	3.377
13/18 TLU 207	2.877	1.877	2.877	3.877
13/18 TLU 208	3.377	2.377	1.377	2.377
13/18 TLU 209	3.377	2.377	1.877	2.877
13/18 TLU 210	3.377	2.377	2.377	3.377
13/18 TLU 211	3.377	2.377	2.877	3.877
13/18 TLU 212	3.877	2.877	1.877	2.877
13/18 TLU 213	3.877	2.877	2.377	3.377
13/18 TLU 214	3.877	2.877	2.877	3.877

Standard Laminated Construction

ITEM NO.	A	A2	B2	B
13/18 SLU 281	1.877	0.877	0.877	1.877
13/18 SLU 282	1.877	0.877	1.377	2.377
13/18 SLU 283	1.877	0.877	1.877	2.877
13/18 SLU 284	2.377	1.377	0.877	1.877
13/18 SLU 285	2.377	1.377	1.377	2.377
13/18 SLU 286	2.377	1.377	1.877	2.877
13/18 SLU 287	2.377	1.377	2.377	3.377
13/18 SLU 288	2.877	1.877	0.877	1.877
13/18 SLU 289	2.877	1.877	1.377	2.377
13/18 SLU 290	2.877	1.877	1.877	2.877
13/18 SLU 291	2.877	1.877	2.377	3.377
13/18 SLU 292	3.377	2.377	1.377	2.377
13/18 SLU 293	3.377	2.377	1.877	2.877
13/18 SLU 294	3.377	2.377	2.377	3.377

Ordering information for frame and companion insert molds can be found in the front of this section.



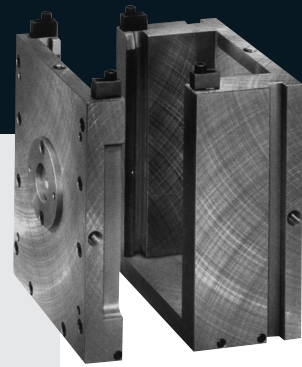

Frame

ITEM NO.

13/20 UF 321

Companion Interchangeable Insert Molds

- 1 Frame clamps at this end of insert mold and ejector plates are flush with this end of insert.
- 2 Support post not supplied. Grind +.001 to +.002 higher than height of ejection (see page C 131).
- 3 Thicker plate optional (quotation on request).
- 4 3/4 x 5° lead this end.

Standard Solid:
9.0 x 18.9

Standard Laminated:
9.0 x 18.9

T-Style Laminated: 12.9
x 18.9

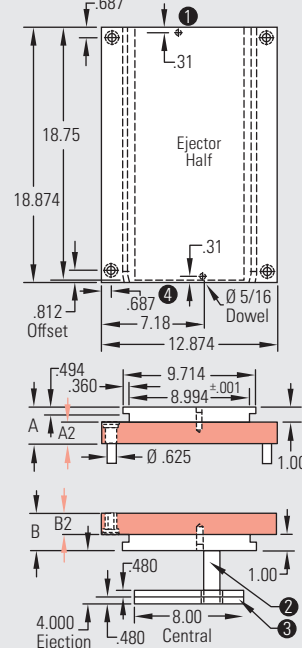
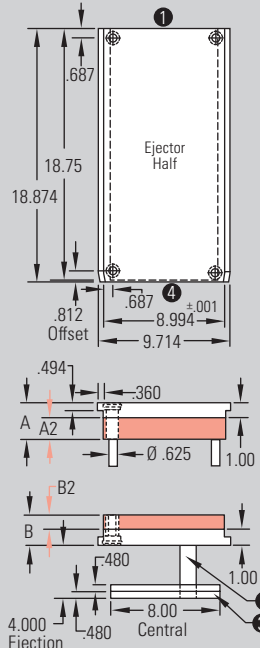
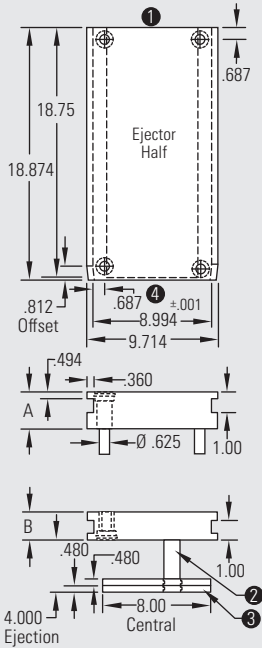

UF 321 Frame Upper – Side View

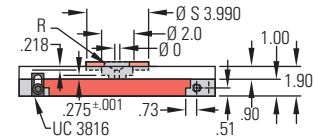

UF 321 Frame Upper – Top View

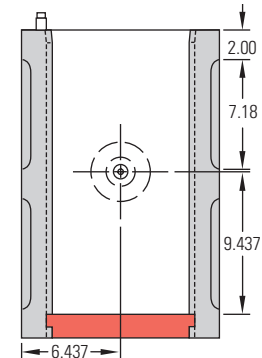

UF 321 Frame Lower – Side View

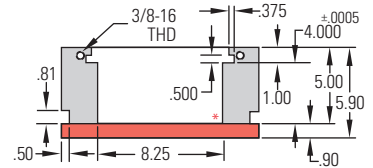

* Taper slot to accommodate sleeve ejection optional (quotation on request).

UF 321 Frame Lower – Top View

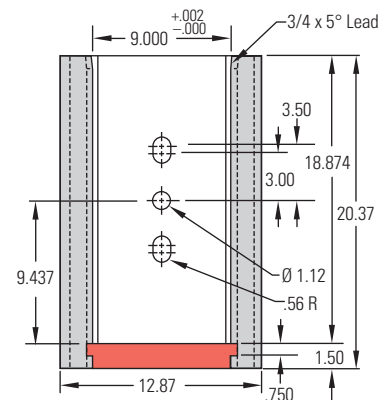

Frame supplied with or without sprue bushing



Standard Solid Construction

ITEM NO.	A	B
13/20 SSU 221	1.377	1.377
13/20 SSU 222	1.377	1.877
13/20 SSU 223	1.377	2.377
13/20 SSU 224	1.877	1.377
13/20 SSU 225	1.877	1.877
13/20 SSU 226	1.877	2.377
13/20 SSU 227	1.877	2.877
13/20 SSU 228	2.377	1.377
13/20 SSU 229	2.377	1.877
13/20 SSU 230	2.377	2.377
13/20 SSU 231	2.377	2.877
13/20 SSU 232	2.877	1.877
13/20 SSU 233	2.877	2.377
13/20 SSU 234	2.877	2.877

T-Style Laminated Construction

ITEM NO.	A	A2	B2	B
13/20 TLU 201	2.377	1.377	1.377	2.377
13/20 TLU 202	2.377	1.377	1.877	2.877
13/20 TLU 203	2.377	1.377	2.377	3.377
13/20 TLU 204	2.877	1.877	1.377	2.377
13/20 TLU 205	2.877	1.877	1.877	2.877
13/20 TLU 206	2.877	1.877	2.377	3.377
13/20 TLU 207	2.877	1.877	2.877	3.877
13/20 TLU 208	3.377	2.377	1.377	2.377
13/20 TLU 209	3.377	2.377	1.877	2.877
13/20 TLU 210	3.377	2.377	2.377	3.377
13/20 TLU 211	3.377	2.377	2.877	3.877
13/20 TLU 212	3.877	2.877	1.877	2.877
13/20 TLU 213	3.877	2.877	2.377	3.377
13/20 TLU 214	3.877	2.877	2.877	3.877

Standard Laminated Construction

ITEM NO.	A	A2	B2	B
13/20 SLU 281	1.877	0.877	0.877	1.877
13/20 SLU 282	1.877	0.877	1.377	2.377
13/20 SLU 283	1.877	0.877	1.877	2.877
13/20 SLU 284	2.377	1.377	0.877	1.877
13/20 SLU 285	2.377	1.377	1.377	2.377
13/20 SLU 286	2.377	1.377	1.877	2.877
13/20 SLU 287	2.377	1.377	2.377	3.377
13/20 SLU 288	2.877	1.877	0.877	1.877
13/20 SLU 289	2.877	1.877	1.377	2.377
13/20 SLU 290	2.877	1.877	1.877	2.877
13/20 SLU 291	2.877	1.877	2.377	3.377
13/20 SLU 292	3.377	2.377	1.377	2.377
13/20 SLU 293	3.377	2.377	1.877	2.877
13/20 SLU 294	3.377	2.377	2.377	3.377

Ordering information for frame and companion insert molds can be found in the front of this section.

MUD® Quick-Change Mold Frames & Inserts for U-Style | 13/20 UF 321



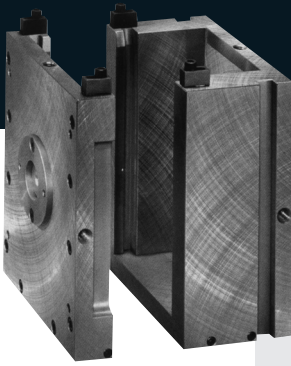

UF Quick-Change U-Style Frame & Companion Insert Molds

Frame

ITEM NO.

13/22 UF 321

Companion Interchangeable Insert Molds

- 1 Frame clamps at this end of insert mold and ejector plates are flush with this end of insert.
- 2 Support post not supplied. Grind $\pm .001$ to $\pm .002$ higher than height of ejection (see page C 131).
- 3 Thicker plate optional (quotation on request).
- 4 $3/4 \times 5^\circ$ lead this end.

Standard Solid:
9.0 x 20.9

Standard Laminated:
9.0 x 20.9

T-Style Laminated: 12.9
x 20.9

UF 321 Frame Upper – Side View

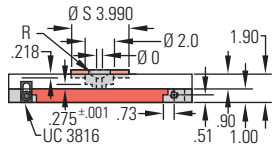

UF 321 Frame Upper – Top View

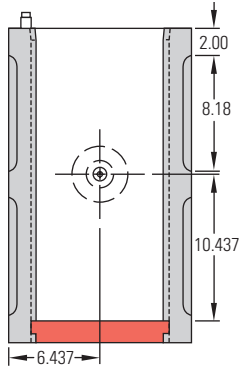

UF 321 Frame Lower – Side View

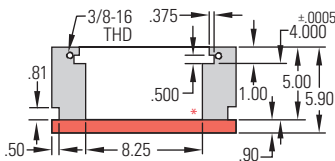

UF 321 Frame Lower – Top View

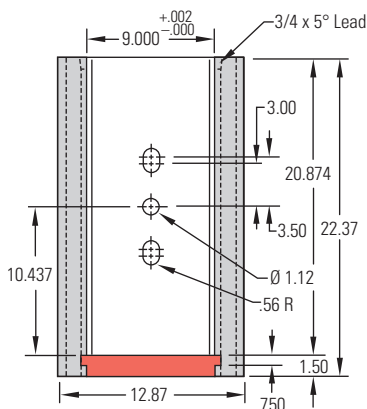

Frame supplied with or without sprue bushing

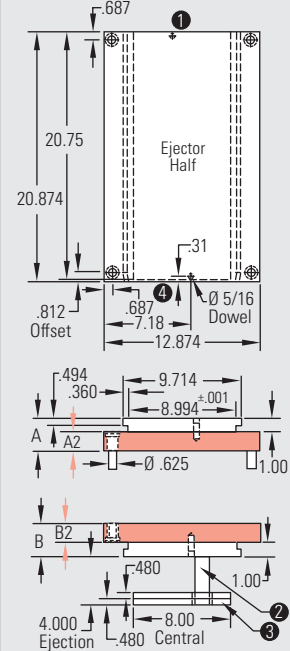
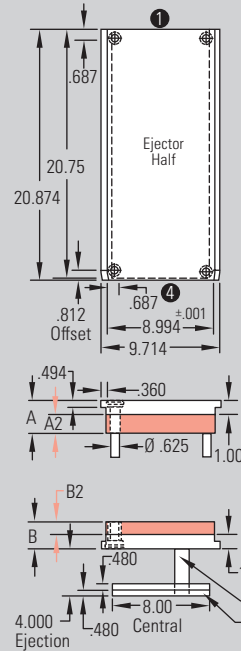
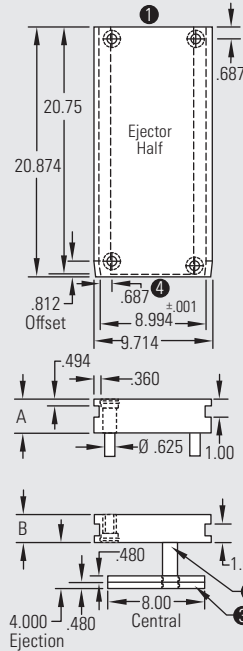

Standard Solid Construction

ITEM NO.	A	B
13/22 SSU 221	1.377	1.377
13/22 SSU 222	1.377	1.877
13/22 SSU 223	1.377	2.377
13/22 SSU 224	1.877	1.377
13/22 SSU 225	1.877	1.877
13/22 SSU 226	1.877	2.377
13/22 SSU 227	1.877	2.877
13/22 SSU 228	2.377	1.377
13/22 SSU 229	2.377	1.877
13/22 SSU 230	2.377	2.377
13/22 SSU 231	2.377	2.877
13/22 SSU 232	2.877	1.877
13/22 SSU 233	2.877	2.377
13/22 SSU 234	2.877	2.877

T-Style Laminated Construction

ITEM NO.	A	A2	B2	B
13/22 TLU 201	2.377	1.377	1.377	2.377
13/22 TLU 202	2.377	1.377	1.877	2.877
13/22 TLU 203	2.377	1.377	2.377	3.377
13/22 TLU 204	2.877	1.877	1.377	2.377
13/22 TLU 205	2.877	1.877	1.877	2.877
13/22 TLU 206	2.877	1.877	2.377	3.377
13/22 TLU 207	2.877	1.877	2.877	3.877
13/22 TLU 208	3.377	2.377	1.377	2.377
13/22 TLU 209	3.377	2.377	1.877	2.877
13/22 TLU 210	3.377	2.377	2.377	3.377
13/22 TLU 211	3.377	2.377	2.877	3.877
13/22 TLU 212	3.877	2.877	1.877	2.877
13/22 TLU 213	3.877	2.877	2.377	3.377
13/22 TLU 214	3.877	2.877	2.877	3.877

Standard Laminated Construction

ITEM NO.	A	A2	B2	B
13/22 SLU 281	1.877	0.877	0.877	1.877
13/22 SLU 282	1.877	0.877	1.377	2.377
13/22 SLU 283	1.877	0.877	1.877	2.877
13/22 SLU 284	2.377	1.377	0.877	1.877
13/22 SLU 285	2.377	1.377	1.377	2.377
13/22 SLU 286	2.377	1.377	1.877	2.877
13/22 SLU 287	2.377	1.377	2.377	3.377
13/22 SLU 288	2.877	1.877	0.877	1.877
13/22 SLU 289	2.877	1.877	1.377	2.377
13/22 SLU 290	2.877	1.877	1.877	2.877
13/22 SLU 291	2.877	1.877	2.377	3.377
13/22 SLU 292	3.377	2.377	1.377	2.377
13/22 SLU 293	3.377	2.377	1.877	2.877
13/22 SLU 294	3.377	2.377	2.377	3.377

Ordering information for frame and companion insert molds can be found in the front of this section.



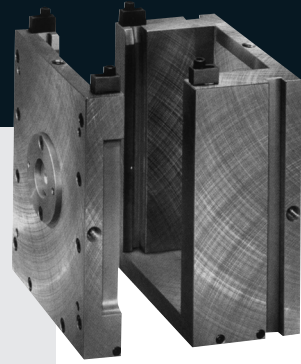

Frame

ITEM NO.
14/16 UF 321

Companion Interchangeable Insert Molds

- 1 Frame clamps at this end of insert mold and ejector plates are flush with this end of insert.
- 2 Support post not supplied. Grind +.001 to +.002 higher than height of ejection (see page C 131).
- 3 Thicker plate optional (quotation on request).
- 4 3/4 x 5° lead this end.

Standard Solid:
10.0 x 14.9

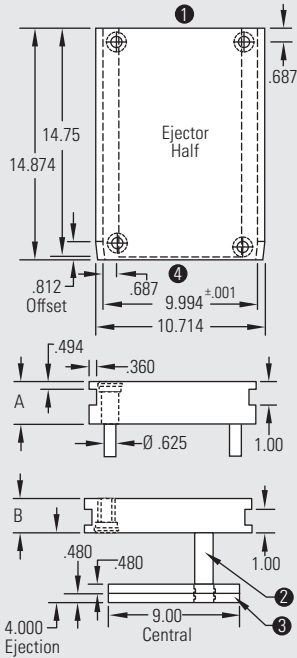

Standard Laminated:
10.0 x 14.9

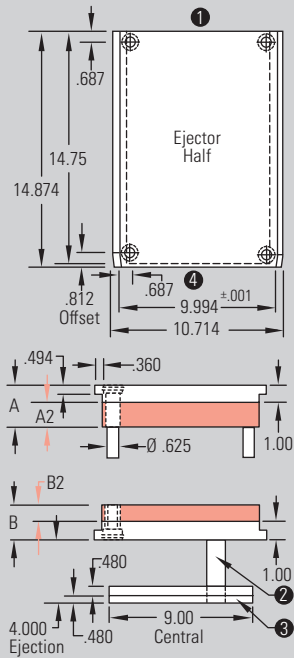

T-Style Laminated: 13.9 x 14.9

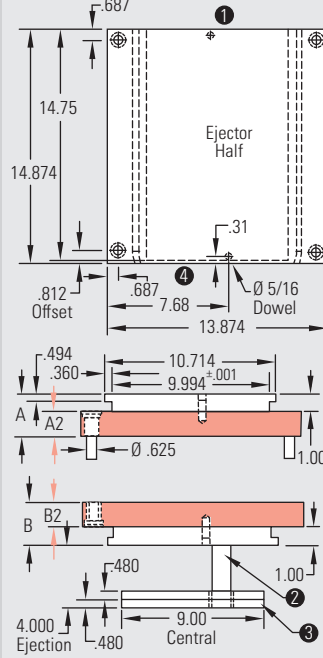

UF 321 Frame Upper – Side View

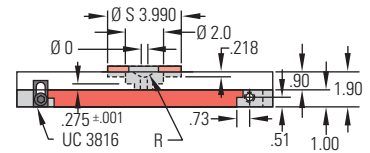

UF 321 Frame Upper – Top View

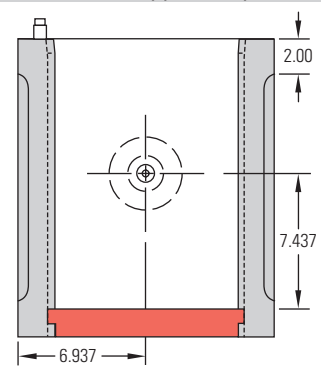

UF 321 Frame Lower – Side View

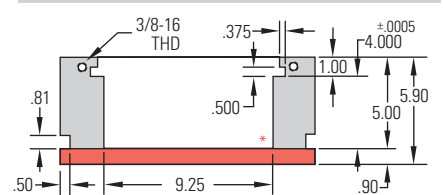

* Taper slot to accommodate sleeve ejection optional (quotation on request).

UF 321 Frame Lower – Top View

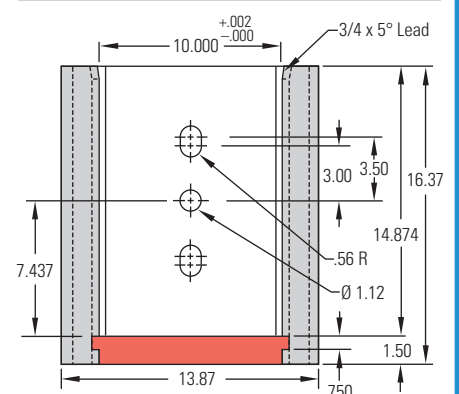

Frame supplied with or without sprue bushing



Standard Solid Construction

ITEM NO.	A	B
14/16 SSU 221	1.377	1.377
14/16 SSU 222	1.377	1.877
14/16 SSU 223	1.377	2.377
14/16 SSU 224	1.877	1.377
14/16 SSU 225	1.877	1.877
14/16 SSU 226	1.877	2.377
14/16 SSU 227	1.877	2.877
14/16 SSU 228	2.377	1.377
14/16 SSU 229	2.377	1.877
14/16 SSU 230	2.377	2.377
14/16 SSU 231	2.377	2.877
14/16 SSU 232	2.877	1.877
14/16 SSU 233	2.877	2.377
14/16 SSU 234	2.877	2.877

T-Style Laminated Construction

ITEM NO.	A	A2	B2	B
14/16 TLU 201	2.377	1.377	1.377	2.377
14/16 TLU 202	2.377	1.377	1.877	2.877
14/16 TLU 203	2.377	1.377	2.377	3.377
14/16 TLU 204	2.877	1.877	1.377	2.377
14/16 TLU 205	2.877	1.877	1.877	2.877
14/16 TLU 206	2.877	1.877	2.377	3.377
14/16 TLU 207	2.877	1.877	2.877	3.877
14/16 TLU 208	3.377	2.377	1.377	2.377
14/16 TLU 209	3.377	2.377	1.877	2.877
14/16 TLU 210	3.377	2.377	2.377	3.377
14/16 TLU 211	3.377	2.377	2.877	3.877
14/16 TLU 212	3.877	2.877	1.877	2.877
14/16 TLU 213	3.877	2.877	2.377	3.377
14/16 TLU 214	3.877	2.877	2.877	3.877

Standard Laminated Construction

ITEM NO.	A	A2	B2	B
14/16 SLU 281	1.877	0.877	0.877	1.877
14/16 SLU 282	1.877	0.877	1.377	2.377
14/16 SLU 283	1.877	0.877	1.877	2.877
14/16 SLU 284	2.377	1.377	0.877	1.877
14/16 SLU 285	2.377	1.377	1.377	2.377
14/16 SLU 286	2.377	1.377	1.877	2.877
14/16 SLU 287	2.377	1.377	2.377	3.377
14/16 SLU 288	2.877	1.877	0.877	1.877
14/16 SLU 289	2.877	1.877	1.377	2.377
14/16 SLU 290	2.877	1.877	1.877	2.877
14/16 SLU 291	2.877	1.877	2.377	3.377
14/16 SLU 292	3.377	2.377	1.377	2.377
14/16 SLU 293	3.377	2.377	1.877	2.877
14/16 SLU 294	3.377	2.377	2.377	3.377

Ordering information for frame and companion insert molds can be found in the front of this section.



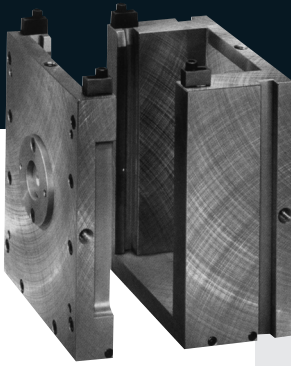

UF Quick-Change U-Style Frame & Companion Insert Molds

Frame

ITEM NO.
14/18 UF 321

Companion Interchangeable Insert Molds

- 1 Frame clamps at this end of insert mold and ejector plates are flush with this end of insert.
- 2 Support post not supplied. Grind $+.001$ to $+.002$ higher than height of ejection (see page C 131).
- 3 Thicker plate optional (quotation on request).
- 4 $3/4 \times 5^\circ$ lead this end.

Standard Solid:
10.0 x 16.9

Standard Laminated: 10.0
x 16.9

T-Style Laminated: 13.9
x 16.9

UF 321 Frame Upper – Side View

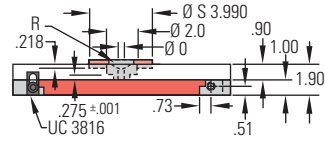

UF 321 Frame Upper – Top View

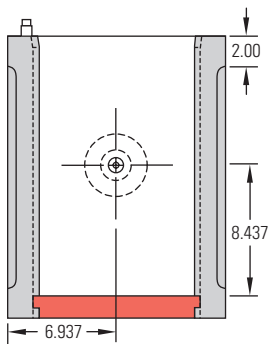

UF 321 Frame Lower – Side View

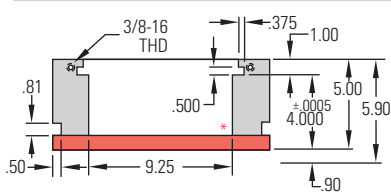

* Taper slot to accommodate sleeve ejection optional (quotation on request).

UF 321 Frame Lower – Top View

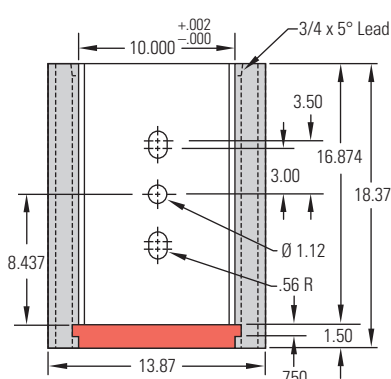

Frame supplied with or without sprue bushing

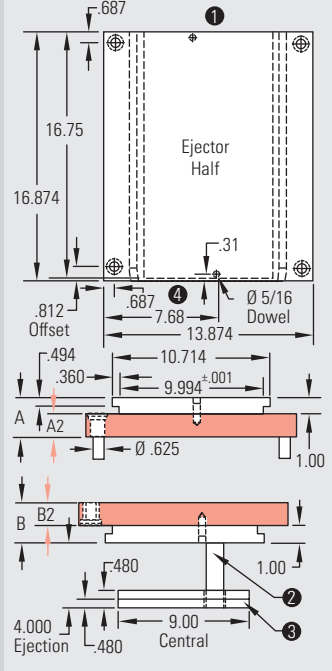
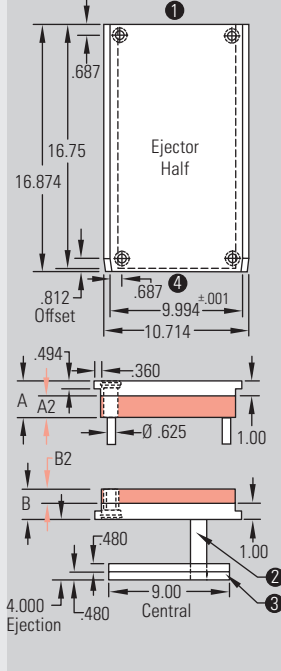
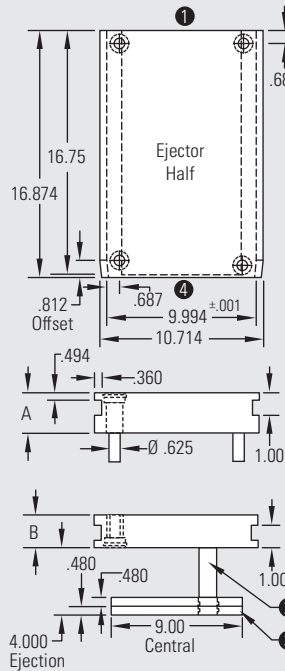

Standard Solid Construction

ITEM NO.	A	B
14/18 SSU 221	1.377	1.377
14/18 SSU 222	1.377	1.877
14/18 SSU 223	1.377	2.377
14/18 SSU 224	1.877	1.377
14/18 SSU 225	1.877	1.877
14/18 SSU 226	1.877	2.377
14/18 SSU 227	1.877	2.877
14/18 SSU 228	2.377	1.377
14/18 SSU 229	2.377	1.877
14/18 SSU 230	2.377	2.377
14/18 SSU 231	2.377	2.877
14/18 SSU 232	2.877	1.877
14/18 SSU 233	2.877	2.377
14/18 SSU 234	2.877	2.877

T-Style Laminated Construction

ITEM NO.	A	A2	B2	B
14/18 TLU 201	2.377	1.377	1.377	2.377
14/18 TLU 202	2.377	1.377	1.877	2.877
14/18 TLU 203	2.377	1.377	2.377	3.377
14/18 TLU 204	2.877	1.877	1.377	2.377
14/18 TLU 205	2.877	1.877	1.877	2.877
14/18 TLU 206	2.877	1.877	2.377	3.377
14/18 TLU 207	2.877	1.877	2.877	3.877
14/18 TLU 208	3.377	2.377	1.377	2.377
14/18 TLU 209	3.377	2.377	1.877	2.877
14/18 TLU 210	3.377	2.377	2.877	3.377
14/18 TLU 211	3.377	2.377	2.877	3.877
14/18 TLU 212	3.877	2.877	1.877	2.877
14/18 TLU 213	3.877	2.877	2.377	3.377
14/18 TLU 214	3.877	2.877	2.877	3.877

Standard Laminated Construction

ITEM NO.	A	A2	B2	B
14/18 SLU 281	1.877	0.877	0.877	1.877
14/18 SLU 282	1.877	0.877	1.377	2.377
14/18 SLU 283	1.877	0.877	1.877	2.877
14/18 SLU 284	2.377	1.377	0.877	1.877
14/18 SLU 285	2.377	1.377	1.377	2.377
14/18 SLU 286	2.377	1.377	1.877	2.877
14/18 SLU 287	2.377	1.377	2.377	3.377
14/18 SLU 288	2.877	1.877	0.877	1.877
14/18 SLU 289	2.877	1.877	1.377	2.377
14/18 SLU 290	2.877	1.877	1.877	2.877
14/18 SLU 291	2.877	1.877	2.377	3.377
14/18 SLU 292	3.377	2.377	1.377	2.377
14/18 SLU 293	3.377	2.377	1.877	2.877
14/18 SLU 294	3.377	2.377	2.377	3.377

Ordering information for frame and companion insert molds can be found in the front of this section.



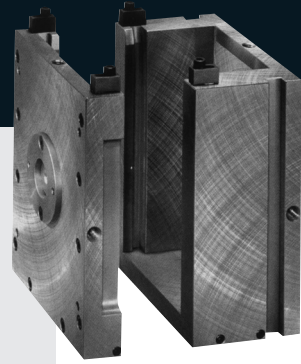

Frame

ITEM NO.
14/20 UF 321

Companion Interchangeable Insert Molds

- 1 Frame clamps at this end of insert mold and ejector plates are flush with this end of insert.
- 2 Support post not supplied. Grind +.001 to +.002 higher than height of ejection (see page C 131).
- 3 Thicker plate optional (quotation on request).
- 4 3/4 x 5° lead this end.

Standard Solid:
10.0 x 18.9

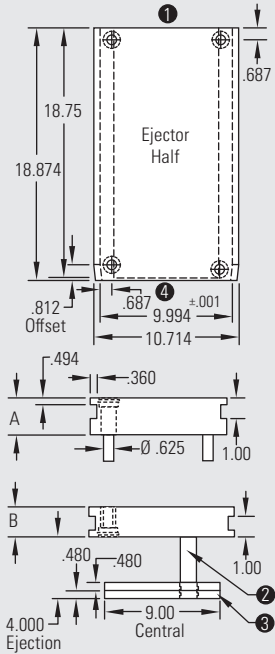

Standard Laminated:
10.0 x 18.9

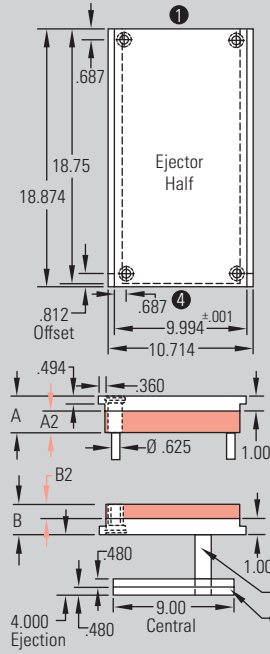

T-Style Laminated: 13.9
x 18.9

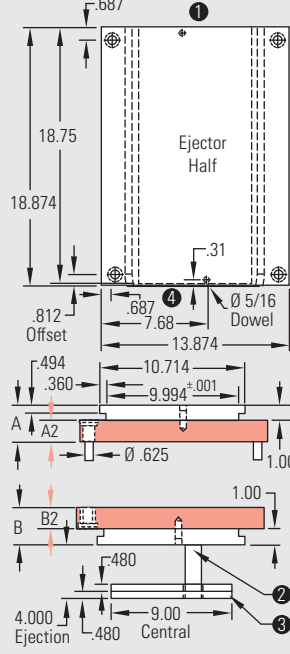

UF 321 Frame Upper – Side View

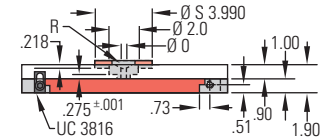

UF 321 Frame Upper – Top View

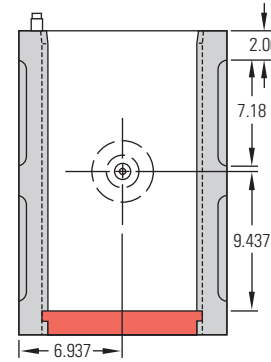

UF 321 Frame Lower – Side View

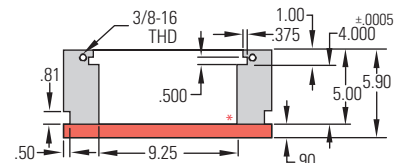

* Taper slot to accommodate sleeve ejection optional (quotation on request).

UF 321 Frame Lower – Top View

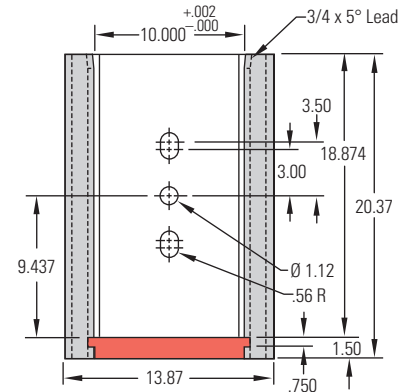

Frame supplied with or without sprue bushing



Standard Solid Construction

ITEM NO.	A	B
14/20 SSU 221	1.377	1.377
14/20 SSU 222	1.377	1.877
14/20 SSU 223	1.377	2.377
14/20 SSU 224	1.877	1.377
14/20 SSU 225	1.877	1.877
14/20 SSU 226	1.877	2.377
14/20 SSU 227	1.877	2.877
14/20 SSU 228	2.377	1.377
14/20 SSU 229	2.377	1.877
14/20 SSU 230	2.377	2.377
14/20 SSU 231	2.377	2.877
14/20 SSU 232	2.877	1.877
14/20 SSU 233	2.877	2.377
14/20 SSU 234	2.877	2.877

T-Style Laminated Construction

ITEM NO.	A	A2	B2	B
14/20 TLU 201	2.377	1.377	1.377	2.377
14/20 TLU 202	2.377	1.377	1.877	2.877
14/20 TLU 203	2.377	1.377	2.377	3.377
14/20 TLU 204	2.877	1.877	1.377	2.377
14/20 TLU 205	2.877	1.877	1.877	2.877
14/20 TLU 206	2.877	1.877	2.377	3.377
14/20 TLU 207	2.877	1.877	2.877	3.877
14/20 TLU 208	3.377	2.377	1.377	2.377
14/20 TLU 209	3.377	2.377	1.877	2.877
14/20 TLU 210	3.377	2.377	2.377	3.377
14/20 TLU 211	3.377	2.377	2.877	3.877
14/20 TLU 212	3.877	2.877	1.877	2.877
14/20 TLU 213	3.877	2.877	2.377	3.377
14/20 TLU 214	3.877	2.877	2.877	3.877

Standard Laminated Construction

ITEM NO.	A	A2	B2	B
14/20 SLU 281	1.877	0.877	0.877	1.877
14/20 SLU 282	1.877	0.877	1.377	2.377
14/20 SLU 283	1.877	0.877	1.877	2.877
14/20 SLU 284	2.377	1.377	0.877	1.877
14/20 SLU 285	2.377	1.377	1.377	2.377
14/20 SLU 286	2.377	1.377	1.877	2.877
14/20 SLU 287	2.377	1.377	2.377	3.377
14/20 SLU 288	2.877	1.877	0.877	1.877
14/20 SLU 289	2.877	1.877	1.377	2.377
14/20 SLU 290	2.877	1.877	1.877	2.877
14/20 SLU 291	2.877	1.877	2.377	3.377
14/20 SLU 292	3.377	2.377	1.377	2.377
14/20 SLU 293	3.377	2.377	1.877	2.877
14/20 SLU 294	3.377	2.377	2.377	3.377

Ordering information for frame and companion insert molds can be found in the front of this section.



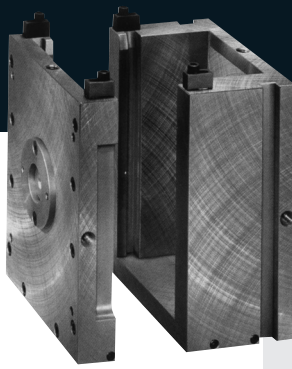

UF Quick-Change U-Style Frame & Companion Insert Molds

Frame

ITEM NO.
14/22 UF 321

UF 321 Frame Upper – Side View

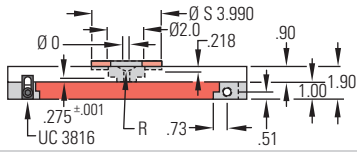

UF 321 Frame Upper – Top View

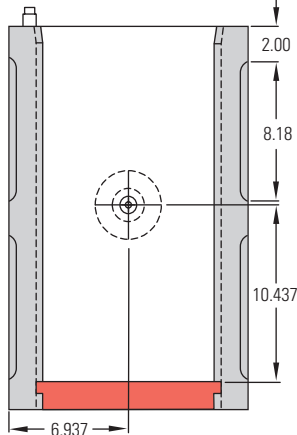

UF 321 Frame Lower – Side View

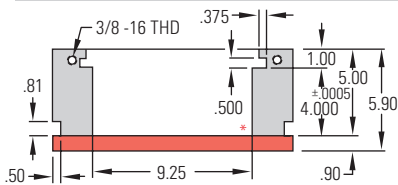

* Taper slot to accommodate sleeve ejection optional (quotation on request).

UF 321 Frame Lower – Top View

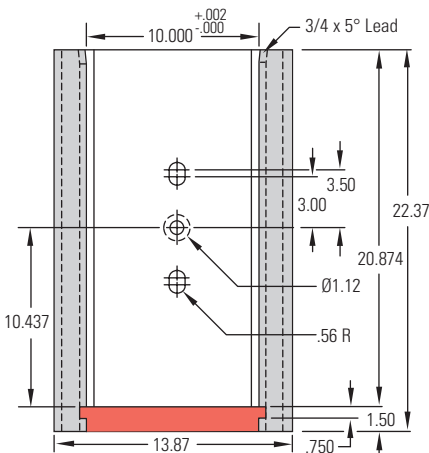

Frame supplied with or without sprue bushing



Companion Interchangeable Insert Molds

- 1 Frame clamps at this end of insert mold and ejector plates are flush with this end of insert.
- 2 Support post not supplied. Grind $+.001$ to $+.002$ higher than height of ejection (see page C 131).
- 3 Thicker plate optional (quotation on request).
- 4 $3/4 \times 5^\circ$ lead this end.

Standard Solid:
10.0 x 20.9

Standard Laminated:
10.0 x 20.9

T-Style Laminated:
13.9 x 20.9

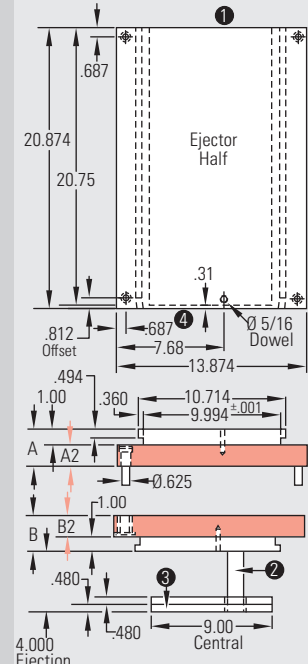
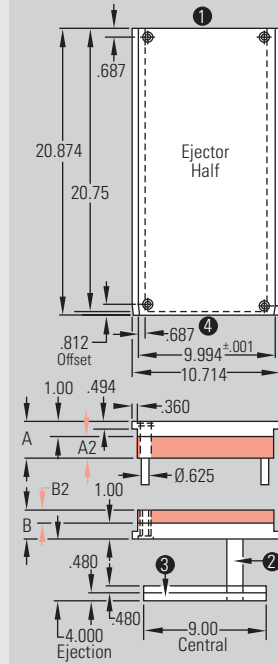
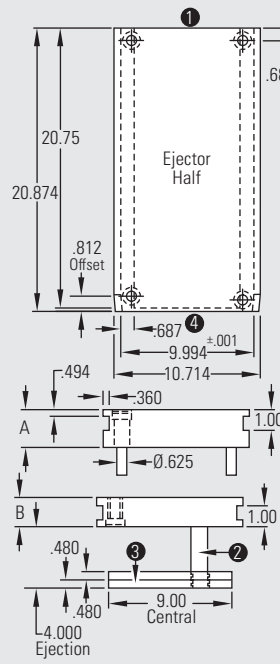

Standard Solid Construction

ITEM NO.	A	B
14/22 SSU 221	1.377	1.377
14/22 SSU 222	1.377	1.877
14/22 SSU 223	1.377	2.377
14/22 SSU 224	1.877	1.377
14/22 SSU 225	1.877	1.877
14/22 SSU 226	1.877	2.377
14/22 SSU 227	1.877	2.877
14/22 SSU 228	2.377	1.377
14/22 SSU 229	2.377	1.877
14/22 SSU 230	2.377	2.377
14/22 SSU 231	2.377	2.877
14/22 SSU 232	2.877	1.877
14/22 SSU 233	2.877	2.377
14/22 SSU 234	2.877	2.877

T-Style Laminated Construction

ITEM NO.	A	A2	B2	B
14/22 TLU 201	2.377	1.377	1.377	2.377
14/22 TLU 202	2.377	1.377	1.877	2.877
14/22 TLU 203	2.377	1.377	2.377	3.377
14/22 TLU 204	2.877	1.877	1.377	2.377
14/22 TLU 205	2.877	1.877	1.877	2.877
14/22 TLU 206	2.877	1.877	2.377	3.377
14/22 TLU 207	2.877	1.877	2.877	3.877
14/22 TLU 208	3.377	2.377	1.377	2.377
14/22 TLU 209	3.377	2.377	1.877	2.877
14/22 TLU 210	3.377	2.377	2.377	3.377
14/22 TLU 211	3.377	2.377	2.877	3.877
14/22 TLU 212	3.877	2.877	1.877	2.877
14/22 TLU 213	3.877	2.877	2.377	3.377
14/22 TLU 214	3.877	2.877	2.877	3.877

Standard Laminated Construction

ITEM NO.	A	A2	B2	B
14/22 SLU 281	1.877	0.877	0.877	1.877
14/22 SLU 282	1.877	0.877	1.377	2.377
14/22 SLU 283	1.877	0.877	1.877	2.877
14/22 SLU 284	2.377	1.377	0.877	1.877
14/22 SLU 285	2.377	1.377	1.377	2.377
14/22 SLU 286	2.377	1.377	1.877	2.877
14/22 SLU 287	2.377	1.377	2.377	3.377
14/22 SLU 288	2.877	1.877	0.877	1.877
14/22 SLU 289	2.877	1.877	1.377	2.377
14/22 SLU 290	2.877	1.877	1.877	2.877
14/22 SLU 291	2.877	1.877	2.377	3.377
14/22 SLU 292	3.377	2.377	1.377	2.377
14/22 SLU 293	3.377	2.377	1.877	2.877
14/22 SLU 294	3.377	2.377	2.377	3.377

Ordering information for frame and companion insert molds can be found in the front of this section.



Frame

ITEM NO.

16/18 UF 321

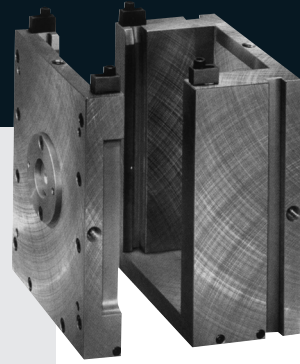

Companion Interchangeable Insert Molds

- 1 Frame clamps at this end of insert mold and ejector plates are flush with this end of insert.
- 2 Support post not supplied. Grind +.001 to +.002 higher than height of ejection (see page C 131).
- 3 Thicker plate optional (quotation on request).
- 4 3/4 x 5° lead this end.

Standard Solid:
11.0 x 15.9

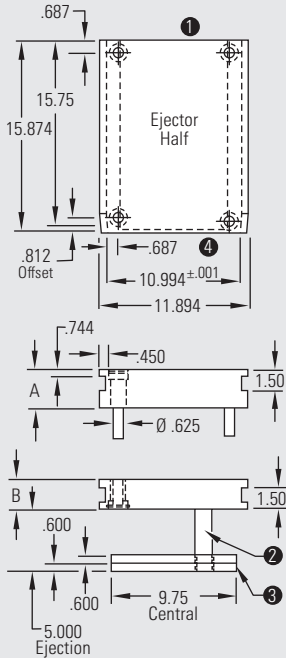

Standard Laminated:
11.0 x 15.9

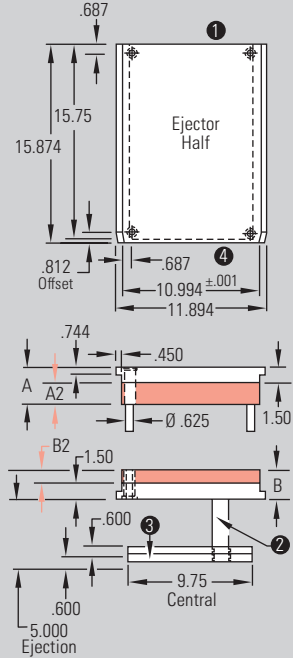

T-Style Laminated: 15.9
x 15.9

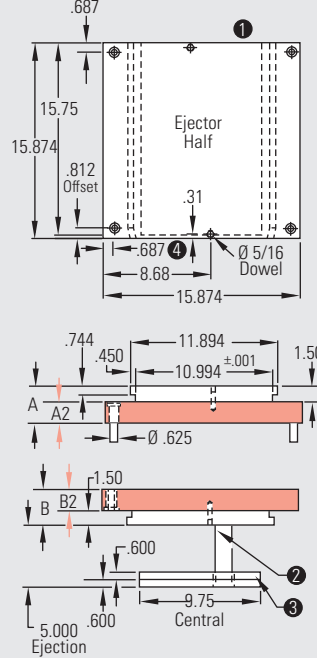

UF 321 Frame Upper – Side View

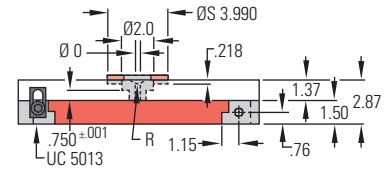

UF 321 Frame Upper – Top View

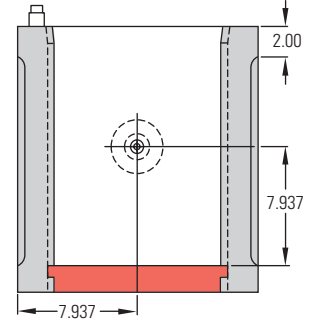

UF 321 Frame Lower – Side View

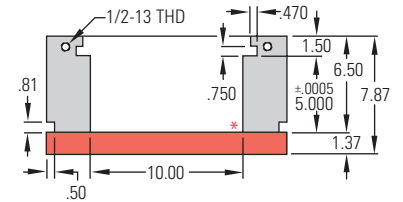

UF 321 Frame Lower – Top View

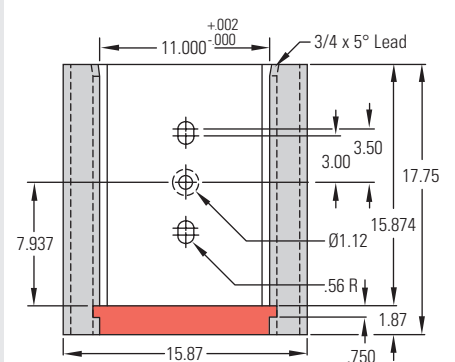

Frame supplied with or without sprue bushing



Standard Solid Construction

ITEM NO.	A	B
16/18 SSU 221	1.877	1.877
16/18 SSU 222	1.877	2.377
16/18 SSU 223	1.877	2.877
16/18 SSU 224	1.877	3.377
16/18 SSU 225	2.377	1.877
16/18 SSU 226	2.377	2.377
16/18 SSU 227	2.377	2.877
16/18 SSU 228	2.377	3.377
16/18 SSU 229	2.877	1.877
16/18 SSU 230	2.877	2.377
16/18 SSU 231	2.877	2.877
16/18 SSU 232	2.877	3.377
16/18 SSU 233	3.377	1.877
16/18 SSU 234	3.377	2.377
16/18 SSU 235	3.377	2.877
16/18 SSU 236	3.377	3.377

T-Style Laminated Construction

ITEM NO.	A	A2	B2	B
16/18 TLU 201	2.877	1.377	1.377	2.877
16/18 TLU 202	2.877	1.377	1.877	3.377
16/18 TLU 203	2.877	1.377	2.377	3.877
16/18 TLU 204	3.377	1.877	1.377	2.877
16/18 TLU 205	3.377	1.877	1.877	3.377
16/18 TLU 206	3.377	1.877	2.377	3.877
16/18 TLU 207	3.377	1.877	2.877	4.377
16/18 TLU 208	3.877	2.377	1.377	2.877
16/18 TLU 209	3.877	2.377	1.877	3.377
16/18 TLU 210	3.877	2.377	2.377	3.877
16/18 TLU 211	3.877	2.377	2.877	4.377
16/18 TLU 212	4.377	2.877	1.877	3.377
16/18 TLU 213	4.377	2.877	2.377	3.877
16/18 TLU 214	4.377	2.877	2.877	4.377
16/18 TLU 215	4.877	3.377	3.377	4.877

Standard Laminated Construction

ITEM NO.	A	A2	B2	B
16/18 SLU 281	2.877	1.377	1.377	2.877
16/18 SLU 282	2.877	1.377	1.877	3.377
16/18 SLU 283	2.877	1.377	2.377	3.877
16/18 SLU 284	3.377	1.877	1.377	2.877
16/18 SLU 285	3.377	1.877	1.877	3.377
16/18 SLU 286	3.377	1.877	2.377	3.877
16/18 SLU 287	3.377	1.877	2.877	4.377
16/18 SLU 288	3.877	2.377	1.377	2.877
16/18 SLU 289	3.877	2.377	1.877	3.377
16/18 SLU 290	3.877	2.377	2.377	3.877
16/18 SLU 291	3.877	2.377	2.877	4.377
16/18 SLU 292	4.377	2.877	1.877	3.377
16/18 SLU 293	4.377	2.877	2.377	3.877
16/18 SLU 294	4.377	2.877	2.877	4.377
16/18 SLU 295	4.877	3.377	3.377	4.877

Ordering information for frame and companion insert molds can be found in the front of this section.

MUD® Quick-Change Mold Frames & Inserts for U-Style | 16/18 UF 321



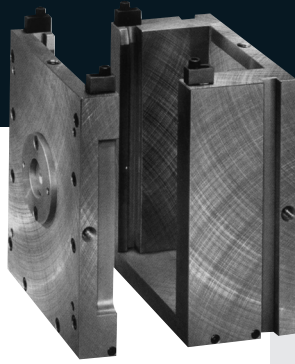

UF Quick-Change U-Style Frame & Companion Insert Molds

Frame

ITEM NO.
16/21 UF 321

UF 321 Frame Upper – Side View

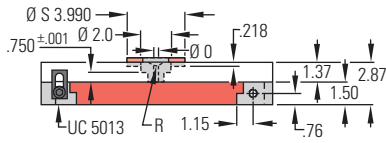

UF 321 Frame Upper – Top View

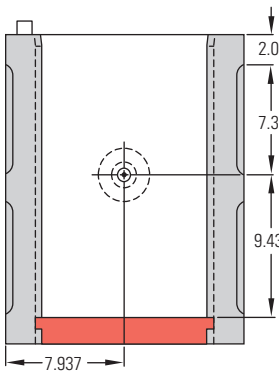

UF 321 Frame Lower – Side View

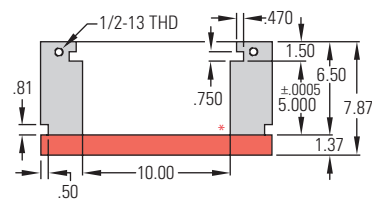

* Taper slot to accommodate sleeve ejection optional (quotation on request).

UF 321 Frame Lower – Top View

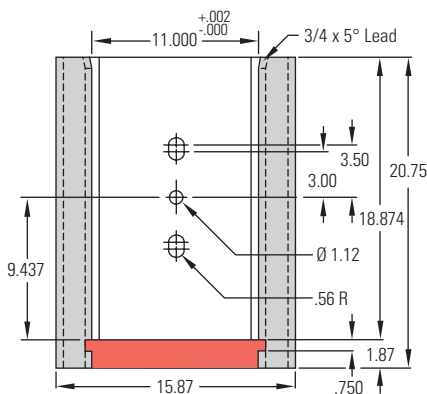

Frame supplied with or without sprue bushing

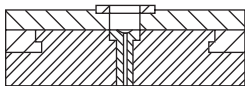

Companion Interchangeable Insert Molds

- 1 Frame clamps at this end of insert mold and ejector plates are flush with this end of insert.
- 2 Support post not supplied. Grind $+.001$ to $+.002$ higher than height of ejection (see page C 131).
- 3 Thicker plate optional (quotation on request).
- 4 $3/4 \times 5^\circ$ lead this end.

Standard Solid:
11.0 x 18.9

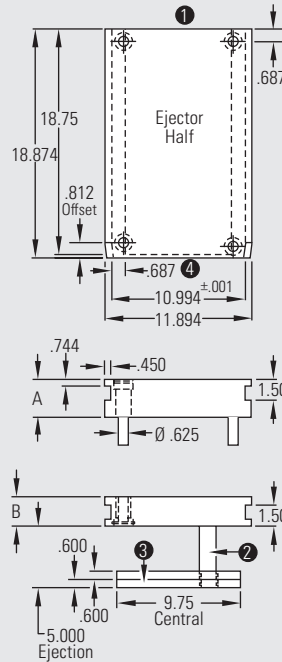

Standard Laminated:
11.0 x 18.9

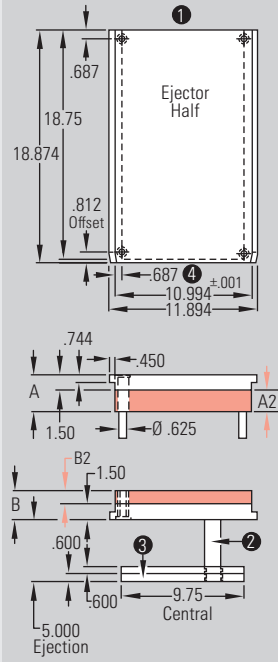

T-Style Laminated: 15.9 x 18.9

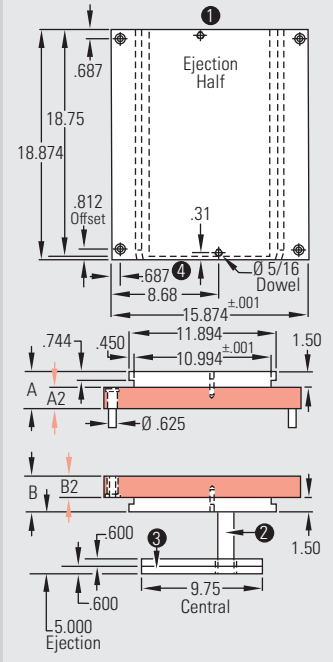

Standard Solid Construction

ITEM NO.	A	B
16/21 SSU 221	1.877	1.877
16/21 SSU 222	1.877	2.377
16/21 SSU 223	1.877	2.877
16/21 SSU 224	1.877	3.377
16/21 SSU 225	2.377	1.877
16/21 SSU 226	2.377	2.377
16/21 SSU 227	2.377	2.877
16/21 SSU 228	2.377	3.377
16/21 SSU 229	2.877	1.877
16/21 SSU 230	2.877	2.377
16/21 SSU 231	2.877	2.877
16/21 SSU 232	2.877	3.377
16/21 SSU 233	3.377	1.877
16/21 SSU 234	3.377	2.377
16/21 SSU 235	3.377	2.877
16/21 SSU 236	3.377	3.377

Standard Laminated Construction

ITEM NO.	A	A2	B2	B
16/21 SLU 281	2.877	1.377	1.377	2.877
16/21 SLU 282	2.877	1.377	1.877	3.377
16/21 SLU 283	2.877	1.377	2.377	3.877
16/21 SLU 284	3.377	1.877	1.377	2.877
16/21 SLU 285	3.377	1.877	1.877	3.377
16/21 SLU 286	3.377	1.877	2.377	3.877
16/21 SLU 287	3.377	1.877	2.877	4.377
16/21 SLU 288	3.877	2.377	1.377	2.877
16/21 SLU 289	3.877	2.377	1.877	3.377
16/21 SLU 290	3.877	2.377	2.377	3.877
16/21 SLU 291	3.877	2.377	2.877	4.377
16/21 SLU 292	4.377	2.877	1.877	3.377
16/21 SLU 293	4.377	2.877	2.377	3.877
16/21 SLU 294	4.377	2.877	2.877	4.377
16/21 SLU 295	4.877	3.377	3.377	4.877

T-Style Laminated Construction

ITEM NO.	A	A2	B2	B
16/21 TLU 201	2.877	1.377	1.377	2.877
16/21 TLU 202	2.877	1.377	1.877	3.377
16/21 TLU 203	2.877	1.377	2.377	3.877
16/21 TLU 204	3.377	1.877	1.377	2.877
16/21 TLU 205	3.377	1.877	1.877	3.377
16/21 TLU 206	3.377	1.877	2.377	3.877
16/21 TLU 207	3.377	1.877	2.877	4.377
16/21 TLU 208	3.877	2.377	1.377	2.877
16/21 TLU 209	3.877	2.377	1.877	3.377
16/21 TLU 210	3.877	2.377	2.377	3.877
16/21 TLU 211	3.877	2.377	2.877	4.377
16/21 TLU 212	4.377	2.877	1.877	3.377
16/21 TLU 213	4.377	2.877	2.377	3.877
16/21 TLU 214	4.377	2.877	2.877	4.377
16/21 TLU 215	4.877	3.377	3.377	4.877

Ordering information for frame and companion insert molds can be found in the front of this section.



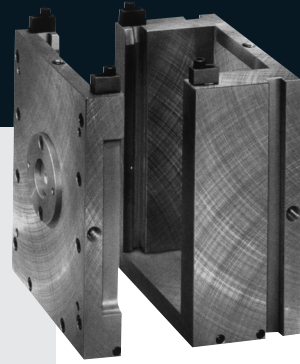

Frame

ITEM NO.

16/24 UF 321

Companion Interchangeable Insert Molds

- 1 Frame clamps at this end of insert mold and ejector plates are flush with this end of insert.
- 2 Support post not supplied. Grind +.001 to +.002 higher than height of ejection (see page C 131).
- 3 Thicker plate optional (quotation on request).
- 4 3/4 x 5° lead this end.

Standard Solid:
11.0 x 21.9

Standard Laminated:
11.0 x 21.9

T-Style Laminated: 15.9
x 21.9

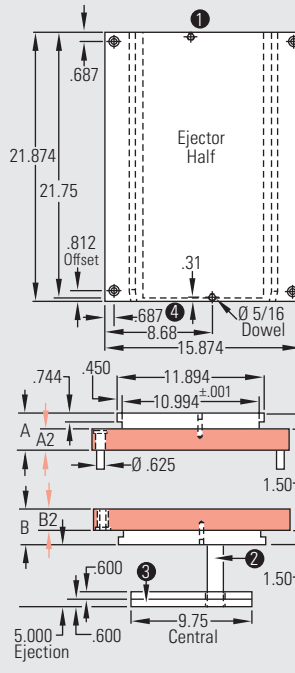
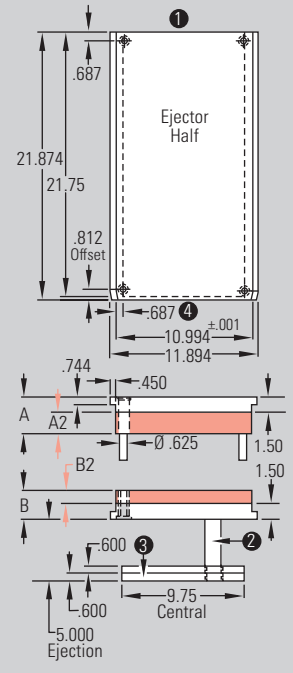
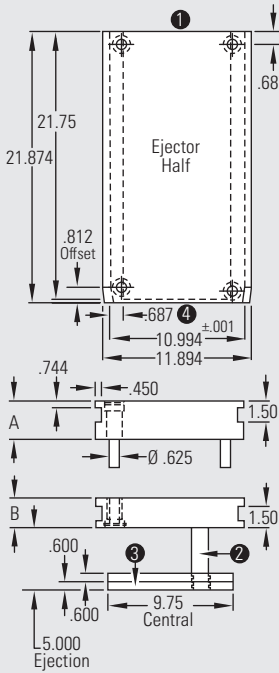

UF 321 Frame Upper – Side View

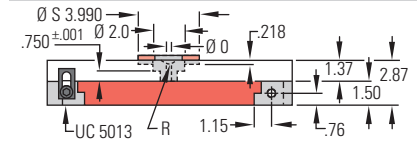

UF 321 Frame Upper – Top View

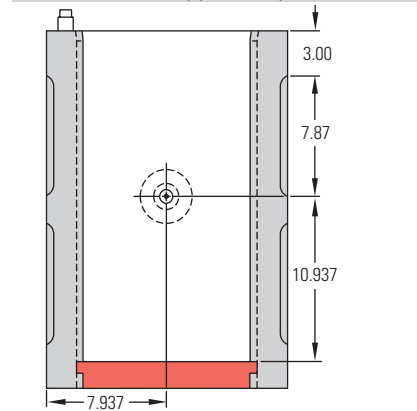

UF 321 Frame Lower – Side View

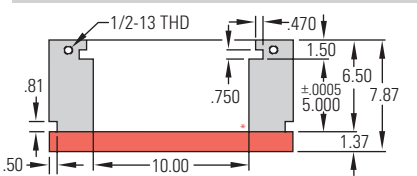

* Taper slot to accommodate sleeve ejection optional (quotation on request).

UF 321 Frame Lower – Top View

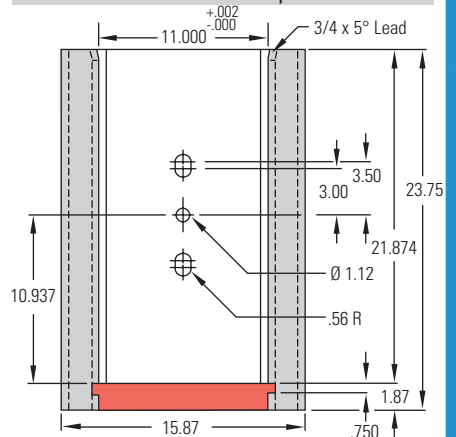

Frame supplied with or without sprue bushing



Standard Solid Construction

ITEM NO.	A	B
16/24 SSU 221	1.877	1.877
16/24 SSU 222	1.877	2.377
16/24 SSU 223	1.877	2.877
16/24 SSU 224	1.877	3.377
16/24 SSU 225	2.377	1.877
16/24 SSU 226	2.377	2.377
16/24 SSU 227	2.377	2.877
16/24 SSU 228	2.377	3.377
16/24 SSU 229	2.877	1.877
16/24 SSU 230	2.877	2.377
16/24 SSU 231	2.877	2.877
16/24 SSU 232	2.877	3.377
16/24 SSU 233	3.377	1.877
16/24 SSU 234	3.377	2.377
16/24 SSU 235	3.377	2.877
16/24 SSU 236	3.377	3.377

T-Style Laminated Construction

ITEM NO.	A	A2	B2	B
16/24 TLU 201	2.877	1.377	1.377	2.877
16/24 TLU 202	2.877	1.377	1.877	3.377
16/24 TLU 203	2.877	1.377	2.377	3.877
16/24 TLU 204	3.377	1.877	1.377	2.877
16/24 TLU 205	3.377	1.877	1.877	3.377
16/24 TLU 206	3.377	1.877	2.377	3.877
16/24 TLU 207	3.377	1.877	2.877	4.377
16/24 TLU 208	3.877	2.377	1.377	2.877
16/24 TLU 209	3.877	2.377	1.877	3.377
16/24 TLU 210	3.877	2.377	2.377	3.877
16/24 TLU 211	3.877	2.377	2.877	4.377
16/24 TLU 212	4.377	2.877	1.877	3.377
16/24 TLU 213	4.377	2.877	2.377	3.877
16/24 TLU 214	4.377	2.877	2.877	4.377
16/24 TLU 215	4.877	3.377	3.377	4.877

Ordering information for frame and companion insert molds can be found in the front of this section.

Standard Laminated Construction

ITEM NO.	A	A2	B2	B
16/24 SLU 281	2.877	1.377	1.377	2.877
16/24 SLU 282	2.877	1.377	1.877	3.377
16/24 SLU 283	2.877	1.377	2.377	3.877
16/24 SLU 284	3.377	1.877	1.377	2.877
16/24 SLU 285	3.377	1.877	1.877	3.377
16/24 SLU 286	3.377	1.877	2.377	3.877
16/24 SLU 287	3.377	1.877	2.877	4.377
16/24 SLU 288	3.877	2.377	1.377	2.877
16/24 SLU 289	3.877	2.377	1.877	3.377
16/24 SLU 290	3.877	2.377	2.377	3.877
16/24 SLU 291	3.877	2.377	2.877	4.377
16/24 SLU 292	4.377	2.877	1.877	3.377
16/24 SLU 293	4.377	2.877	2.377	3.877
16/24 SLU 294	4.377	2.877	2.877	4.377
16/24 SLU 295	4.877	3.377	3.377	4.877



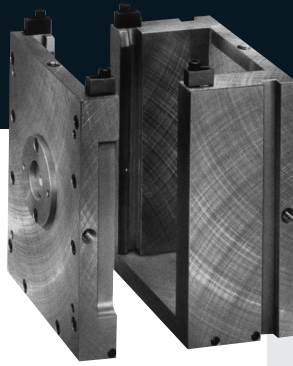

Frame

ITEM NO.
16/27 UF 321

UF Quick-Change U-Style Frame & Companion Insert Molds

Companion Interchangeable Insert Molds

- 1 Frame clamps at this end of insert mold and ejector plates are flush with this end of insert.
- 2 Support post not supplied. Grind +.001 to +.002 higher than height of ejection (see page C 131).
- 3 Thicker plate optional (quotation on request).
- 4 3/4 x 5° lead this end.

Standard Solid:
11.0 x 24.9

Standard Laminated:
11.0 x 24.9

T-Style Laminated: 15.9
x 24.9

UF 321 Frame Upper – Side View

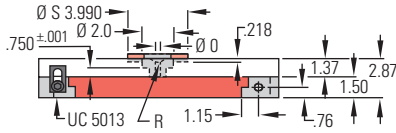

UF 321 Frame Upper – Top View

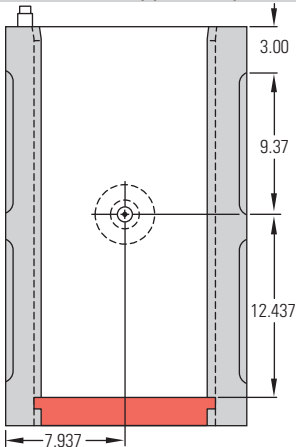

UF 321 Frame Lower – Side View

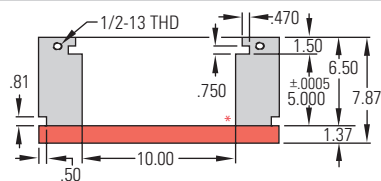

* Taper slot to accommodate sleeve ejection optional (quotation on request).

UF 321 Frame Lower – Top View

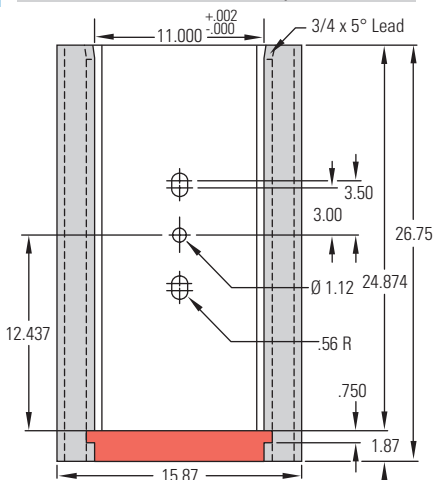

Frame supplied with or without sprue bushing

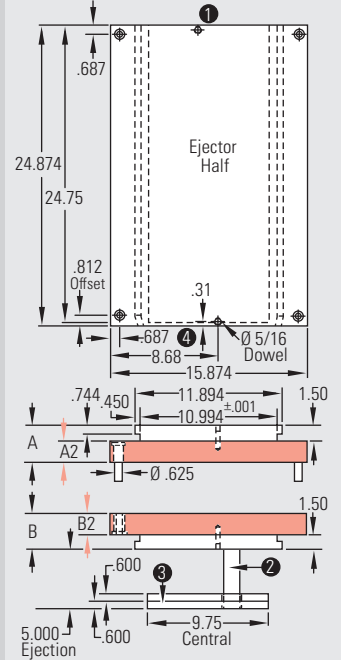
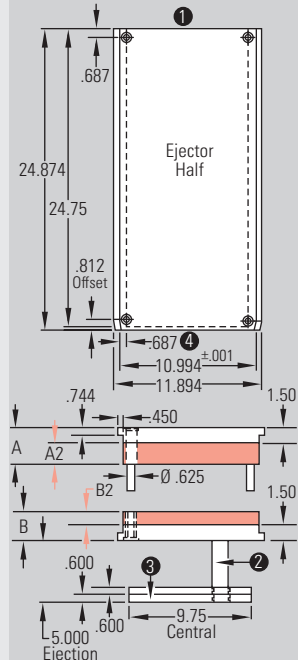
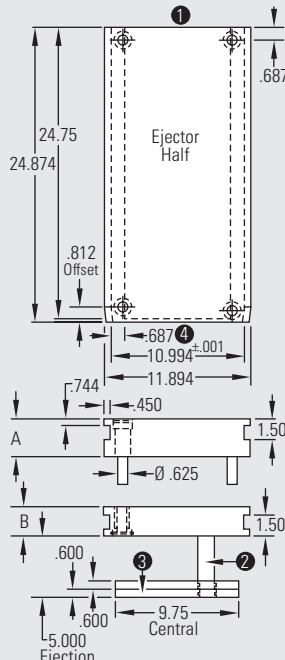

Standard Solid Construction

ITEM NO.	A	B
16/27 SSU 221	1.877	1.877
16/27 SSU 222	1.877	2.377
16/27 SSU 223	1.877	2.877
16/27 SSU 224	1.877	3.377
16/27 SSU 225	2.377	1.877
16/27 SSU 226	2.377	2.377
16/27 SSU 227	2.377	2.877
16/27 SSU 228	2.377	3.377
16/27 SSU 229	2.877	1.877
16/27 SSU 230	2.877	2.377
16/27 SSU 231	2.877	2.877
16/27 SSU 232	2.877	3.377
16/27 SSU 233	3.377	1.877
16/27 SSU 234	3.377	2.377
16/27 SSU 235	3.377	2.877
16/27 SSU 236	3.377	3.377

T-Style Laminated Construction

ITEM NO.	A	A2	B2	B
16/27 TLU 201	2.877	1.377	1.377	2.877
16/27 TLU 202	2.877	1.377	1.877	3.377
16/27 TLU 203	2.877	1.377	2.377	3.877
16/27 TLU 204	3.377	1.877	1.377	2.877
16/27 TLU 205	3.377	1.877	1.877	3.377
16/27 TLU 206	3.377	1.877	2.377	3.877
16/27 TLU 207	3.377	1.877	2.877	4.377
16/27 TLU 208	3.877	2.377	1.377	2.877
16/27 TLU 209	3.877	2.377	1.877	3.377
16/27 TLU 210	3.877	2.377	2.377	3.877
16/27 TLU 211	3.877	2.377	2.877	4.377
16/27 TLU 212	4.377	2.877	1.877	3.377
16/27 TLU 213	4.377	2.877	2.377	3.877
16/27 TLU 214	4.377	2.877	2.877	4.377
16/27 TLU 215	4.877	3.377	3.377	4.877

Ordering information for frame and companion insert molds can be found in the front of this section.

Standard Laminated Construction

ITEM NO.	A	A2	B2	B
16/27 SLU 281	2.877	1.377	1.377	2.877
16/27 SLU 282	2.877	1.377	1.877	3.377
16/27 SLU 283	2.877	1.377	2.377	3.877
16/27 SLU 284	3.377	1.877	1.377	2.877
16/27 SLU 285	3.377	1.877	1.877	3.377
16/27 SLU 286	3.377	1.877	2.377	3.877
16/27 SLU 287	3.377	1.877	2.877	4.377
16/27 SLU 288	3.877	2.377	1.377	2.877
16/27 SLU 289	3.877	2.377	1.877	3.377
16/27 SLU 290	3.877	2.377	2.377	3.877
16/27 SLU 291	3.877	2.377	2.877	4.377
16/27 SLU 292	4.377	2.877	1.877	3.377
16/27 SLU 293	4.377	2.877	2.377	3.877
16/27 SLU 294	4.377	2.877	2.877	4.377
16/27 SLU 295	4.877	3.377	3.377	4.877



Frame

ITEM NO.

18/20 UF 321

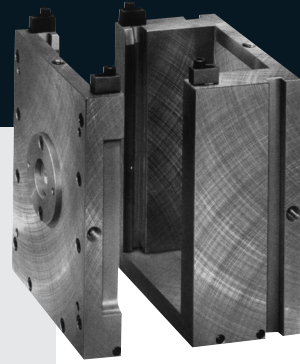

Companion Interchangeable Insert Molds

- 1 Frame clamps at this end of insert mold and ejector plates are flush with this end of insert.
- 2 Support post not supplied. Grind +.001 to +.002 higher than height of ejection (see page C 131).
- 3 Thicker plate optional (quotation on request).
- 4 3/4 x 5° lead this end.

Standard Solid:
12.0 x 17.9

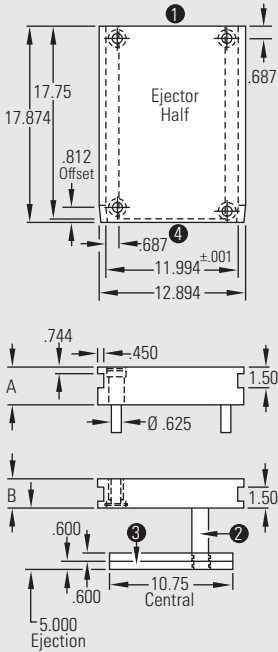

Standard Laminated:
12.0 x 17.9

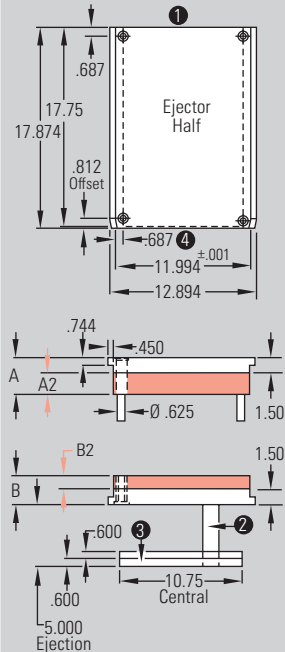

T-Style Laminated: 17.9
x 17.9

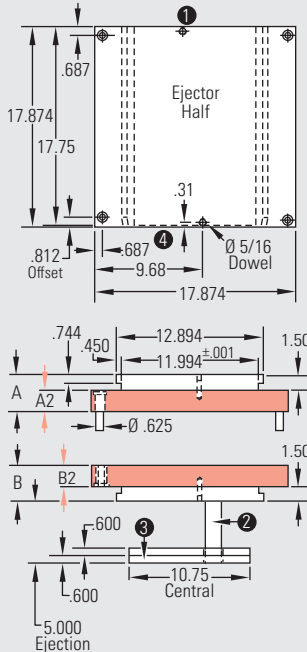

UF 321 Frame Upper – Side View

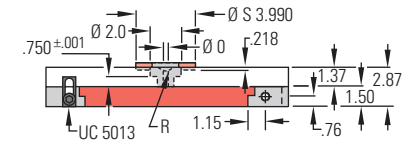

UF 321 Frame Upper – Top View

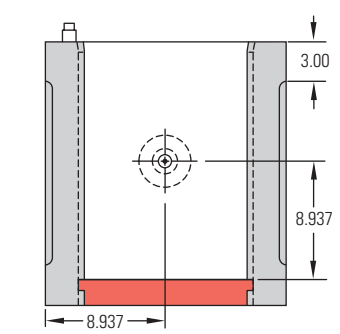

UF 321 Frame Lower – Side View

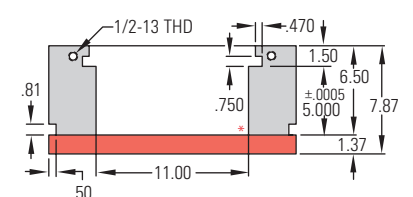

UF 321 Frame Lower – Top View

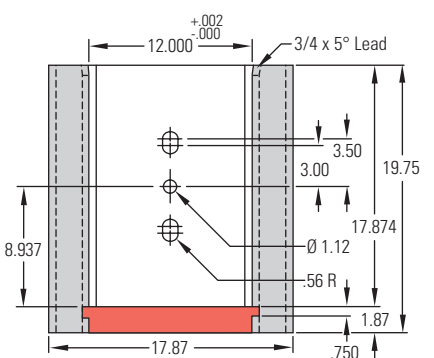

Frame supplied with or without sprue bushing

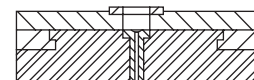

Standard Solid Construction

ITEM NO.	A	B
18/20 SSU 221	1.877	1.877
18/20 SSU 222	1.877	2.377
18/20 SSU 223	1.877	2.877
18/20 SSU 224	1.877	3.377
18/20 SSU 225	2.377	1.877
18/20 SSU 226	2.377	2.377
18/20 SSU 227	2.377	2.877
18/20 SSU 228	2.377	3.377
18/20 SSU 229	2.877	1.877
18/20 SSU 230	2.877	2.377
18/20 SSU 231	2.877	2.877
18/20 SSU 232	2.877	3.377
18/20 SSU 233	3.377	1.877
18/20 SSU 234	3.377	2.377
18/20 SSU 235	3.377	2.877
18/20 SSU 236	3.377	3.377

T-Style Laminated Construction

ITEM NO.	A	A2	B2	B
18/20 TLU 201	2.877	1.377	1.377	2.877
18/20 TLU 202	2.877	1.377	1.877	3.377
18/20 TLU 203	2.877	1.377	2.377	3.877
18/20 TLU 204	3.377	1.877	1.377	2.877
18/20 TLU 205	3.377	1.877	1.877	3.377
18/20 TLU 206	3.377	1.877	2.377	3.877
18/20 TLU 207	3.377	1.877	2.877	4.377
18/20 TLU 208	3.877	2.377	1.377	2.877
18/20 TLU 209	3.877	2.377	1.877	3.377
18/20 TLU 210	3.877	2.377	2.377	3.877
18/20 TLU 211	3.877	2.377	2.877	4.377
18/20 TLU 212	4.377	2.877	1.877	3.377
18/20 TLU 213	4.377	2.877	2.377	3.877
18/20 TLU 214	4.377	2.877	2.877	4.377
18/20 TLU 215	4.877	3.377	3.377	4.877

Standard Laminated Construction

ITEM NO.	A	A2	B2	B
18/20 SLU 281	2.877	1.377	1.377	2.877
18/20 SLU 282	2.877	1.377	1.877	3.377
18/20 SLU 283	2.877	1.377	2.377	3.877
18/20 SLU 284	3.377	1.877	1.377	2.877
18/20 SLU 285	3.377	1.877	1.877	3.377
18/20 SLU 286	3.377	1.877	2.377	3.877
18/20 SLU 287	3.377	1.877	2.877	4.377
18/20 SLU 288	3.877	2.377	1.377	2.877
18/20 SLU 289	3.877	2.377	1.877	3.377
18/20 SLU 290	3.877	2.377	2.377	3.877
18/20 SLU 291	3.877	2.377	2.877	4.377
18/20 SLU 292	4.377	2.877	1.877	3.377
18/20 SLU 293	4.377	2.877	2.377	3.877
18/20 SLU 294	4.377	2.877	2.877	4.377
18/20 SLU 295	4.877	3.377	3.377	4.877

Ordering information for frame and companion insert molds can be found in the front of this section.



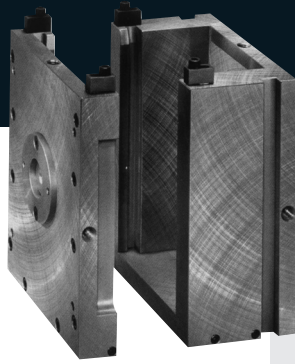

UF Quick-Change U-Style Frame & Companion Insert Molds

Frame

ITEM NO.
18/26 UF 321

Companion Interchangeable Insert Molds

- 1 Frame clamps at this end of insert mold and ejector plates are flush with this end of insert.
- 2 Support post not supplied. Grind $+.001$ to $+.002$ higher than height of ejection (see page C 131).
- 3 Thicker plate optional (quotation on request).
- 4 $3/4 \times 5^\circ$ lead this end.

Standard Solid:
12.0 x 23.9

Standard Laminated:
12.0 x 23.9

T-Style Laminated: 17.9
x 23.9

UF 321 Frame Upper – Side View

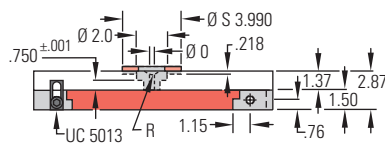

UF 321 Frame Upper – Top View

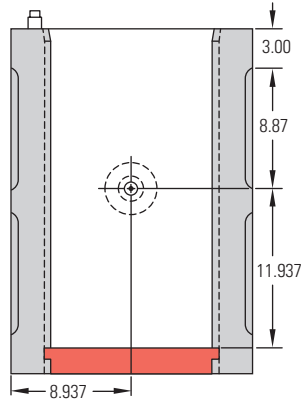

UF 321 Frame Lower – Side View

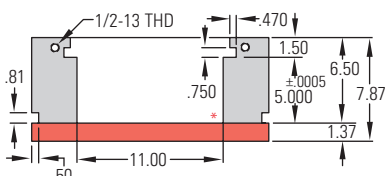

* Taper slot to accommodate sleeve ejection optional (quotation on request).

UF 321 Frame Lower – Top View

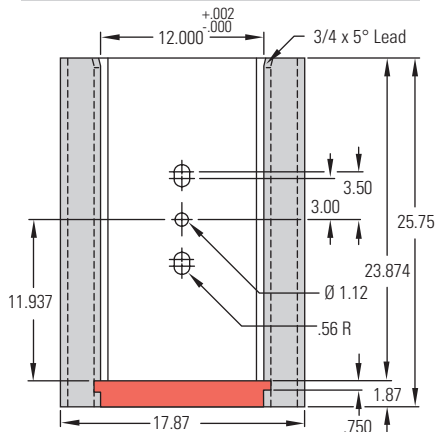

Frame supplied with or without sprue bushing

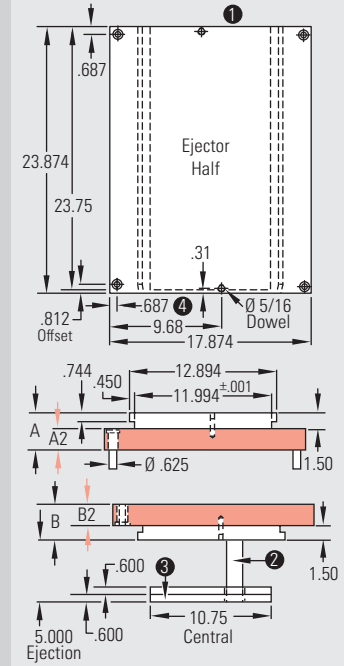
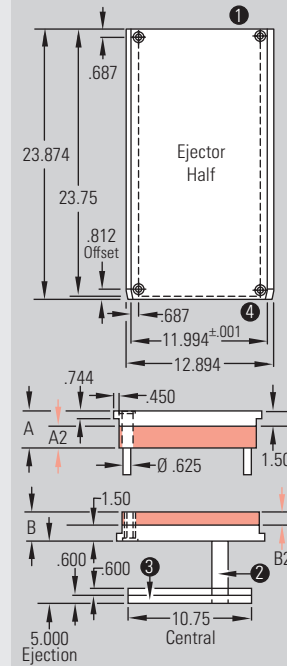
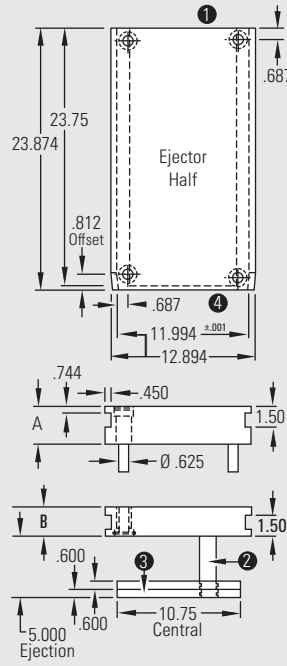

Standard Solid Construction

ITEM NO.	A	B
18/26 SSU 221	1.877	1.877
18/26 SSU 222	1.877	2.377
18/26 SSU 223	1.877	2.877
18/26 SSU 224	1.877	3.377
18/26 SSU 225	2.377	1.877
18/26 SSU 226	2.377	2.377
18/26 SSU 227	2.377	2.877
18/26 SSU 228	2.377	3.377
18/26 SSU 229	2.877	1.877
18/26 SSU 230	2.877	2.377
18/26 SSU 231	2.877	2.877
18/26 SSU 232	2.877	3.377
18/26 SSU 233	3.377	1.877
18/26 SSU 234	3.377	2.377
18/26 SSU 235	3.377	2.877
18/26 SSU 236	3.377	3.377

T-Style Laminated Construction

ITEM NO.	A	A2	B2	B
18/26 TLU 201	2.877	1.377	1.377	2.877
18/26 TLU 202	2.877	1.377	1.877	3.377
18/26 TLU 203	2.877	1.377	2.377	3.877
18/26 TLU 204	3.377	1.877	1.377	2.877
18/26 TLU 205	3.377	1.877	1.877	3.377
18/26 TLU 206	3.377	1.877	2.377	3.877
18/26 TLU 207	3.377	1.877	2.877	4.377
18/26 TLU 208	3.877	2.377	1.377	2.877
18/26 TLU 209	3.877	2.377	1.877	3.377
18/26 TLU 210	3.877	2.377	2.377	3.877
18/26 TLU 211	3.877	2.377	2.877	4.377
18/26 TLU 212	4.377	2.877	1.877	3.377
18/26 TLU 213	4.377	2.877	2.377	3.877
18/26 TLU 214	4.377	2.877	2.877	4.377
18/26 TLU 215	4.877	3.377	3.377	4.877

Standard Laminated Construction

ITEM NO.	A	A2	B2	B
18/26 SLU 281	2.877	1.377	1.377	2.877
18/26 SLU 282	2.877	1.377	1.877	3.377
18/26 SLU 283	2.877	1.377	2.377	3.877
18/26 SLU 284	3.377	1.877	1.377	2.877
18/26 SLU 285	3.377	1.877	1.877	3.377
18/26 SLU 286	3.377	1.877	2.377	3.877
18/26 SLU 287	3.377	1.877	2.877	4.377
18/26 SLU 288	3.877	2.377	1.377	2.877
18/26 SLU 289	3.877	2.377	1.877	3.377
18/26 SLU 290	3.877	2.377	2.377	3.877
18/26 SLU 291	3.877	2.377	2.877	4.377
18/26 SLU 292	4.377	2.877	1.877	3.377
18/26 SLU 293	4.377	2.877	2.377	3.877
18/26 SLU 294	4.377	2.877	2.877	4.377
18/26 SLU 295	4.877	3.377	3.377	4.877

Ordering information for frame and companion insert molds can be found in the front of this section.





Quick-Change Mold Frames & Inserts for H-Style

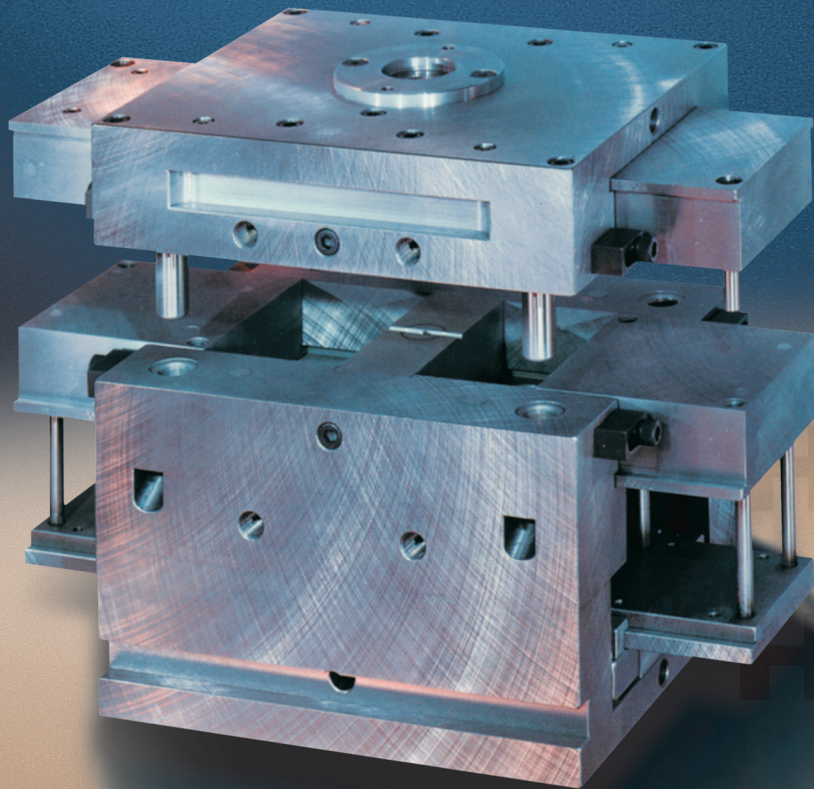

Frame Ordering Information

- Item number and description (see tables on respective page)
- "S" diameter of locating ring supplied standard 3.990" (see illustrations on respective page)
- Sprue specification "R" spherical radius of sprue bushing furnished 1/2" or 3/4" unless otherwise shown
- "O" small diameter of sprue bushing orifice furnished 5/32", 7/32", 9/32" or 11/32", unless otherwise shown
- Optional locating rings available on request
- Knockout hole location standard as shown (others optional)
- Runner size and description
- Cutouts in master ejector plate for insert mold pillar posts standard as shown on respective page
- Clamp slots standard unless otherwise shown on respective page
- Mounting holes optional unless shown on respective page
- Additional ejection height available (quotation on request)
- Frames standard in prehard steel with hardened steel center section; prehard stainless and other steel grades available (quotation on request)

Insert Mold Ordering Information

- Item number and description (see tables on respective page)
- Steel grades – 1020, 4130 prehard, P-20 prehard and H-13: 420 stainless and other grades on request
- H-13 and other tool steel insert molds supplied .010 oversize on outside dimensions, .010 – .013 oversize on thickness, and .025 – .035 undersize in the pin and bushing holes for machining after required heat treating
- "A" and "B" dimensions supplied .004 – .007 oversize unless otherwise specified
- NOTE: The "A" and "B" dimensions for insert mold must match those of the companion H frame.

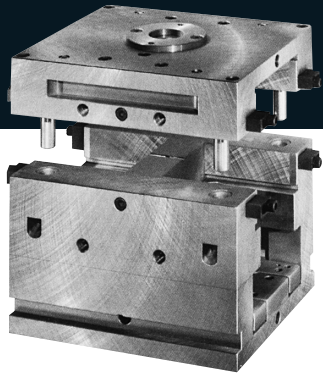

Quick-Change H frame options

- Spring-loaded master ejector plates
- Interlocking ejector rails
- Additional height on ejector rails
- Early return on ejector system
- Special knockout hole locations
- Runner shutoffs
- Choice of runner configuration
- Frame spacer bars
- Insulation boards
- Additional retainer slot and spacer plate
- Extended loading rails
- Water lines for center sections
- Water lines for rails and plates
- Machining for cartridge heaters
- Manifold for hot runner operation
- Hot sprue bushings
- Coating options
- Electroless nickel plating

NOTE: Specifications subject to change without prior notice.

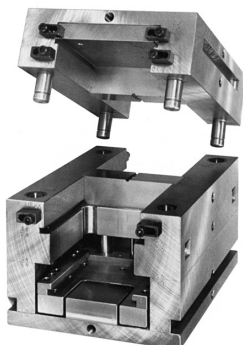

Quick-Change H frame features and applications

This MUD® Quick-Change frame series features a center runner bar for simultaneous molding with two standard-style companion insert molds. The series offers cost reduction benefits and time-saving advantages similar to the U frame series. It also provides comparable design flexibility.

The two companion insert molds for H frames can be changed independently and individually. A dummy insert is supplied for single insert mold production. This results in exceptional versatility for tailoring schedules to virtually all inventory requirements including just-in-time delivery.

H frames also offer special advantages for high volume production. Two insert molds permit doubling quantities for each molding cycle. Also, there is virtually no need to interrupt production for maintenance or repair since inexpensive backup insert molds can be quickly installed.

H frames are supplied with hardened center runner bars and replaceable sprue puller pin assemblies. Each frame includes a locking locating ring and an integral master ejector plate with cutouts to allow installation of insert mold pillar posts. The master ejector plate is also supplied with positive aligning guide posts, bushings and grease fittings for a guided ejector system.

Options include interlocking ejector rails to lock the insert mold's ejector system to the master ejector plate. The master ejector plate can be spring loaded for returning the insert mold's ejector system. It can also be tied to the machine's hydraulic knockout system for stroking the insert mold's ejector assembly.

Other options include water lines in the center bar or other locations, insulation boards, runner shutoffs and hot sprue bushings. Frame spacer bars to accommodate shorter, more economical companion insert molds are available for frames designed for longer sizes. Additional retainer slots and a spacer plate in the frame's cavity half allow the frame to accept insert molds with different thicknesses.

Quick-Change Hot Runner Molding

All of the advantages of the MUD® Quick-Change Concept can be added to a hot runner molding system with the addition of a manifold to the H frame. Both the frame and the hot runner system remain in the molding machine. Only the insert molds are changed to produce new parts, just as in other Quick-Change applications. This means faster changeovers, lower tooling costs and greater scheduling flexibility for hot runner molding.

Steel specifications: Standard frames are produced in prehard steel (285-325 Brinell) with hardened center sections. Frames are also available in prehard stainless, 420 stainless, H-13 and other grades on request. Frame coating can be specified.

Companion insert mold features and applications

Standard style companion insert molds for H frames are available in solid or laminated construction and include three- and four-plate designs.

Insert mold options include machining for stripper plates, sleeve ejection, return pins and pillar posts. Machining for cartridge heater holes, water lines, taper locks, rough and finished custom pockets and other special applications is available.

Design options for insert molds include spring loading, early return, unscrewing mechanisms, hot runner molding and machining for cam slides. Insert molds can be ordered with interlocking ejector plates for positive return and stroking action when used with frames having an interlocking ejector system.

Steel specifications: Companion insert molds are available in 1020, 4130 prehard, P-20 prehard and H-13. 420 stainless and other grades are available on request.

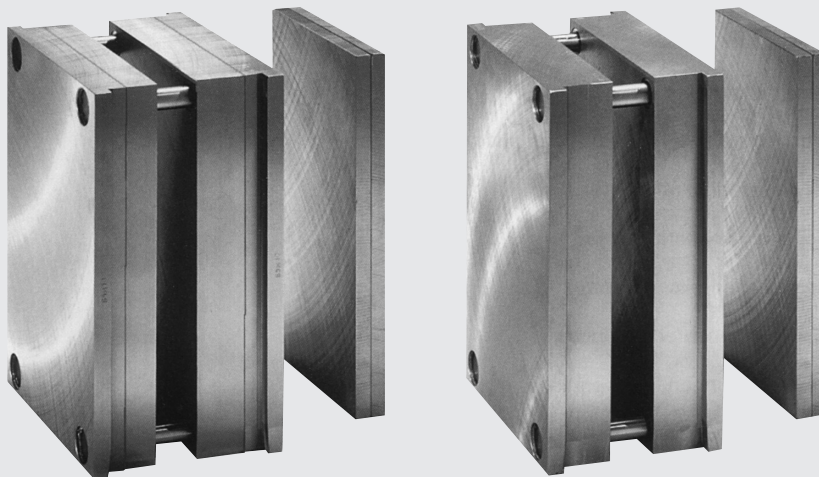

Companion insert mold options

- Solid or laminated construction
- Stripper plates
- Interlocking ejector plates
- Return pins
- Pillar posts
- Sleeve ejection
- Machining for taper locks
- Machining for cartridge heater holes
- Machining for water lines
- Rough cut pockets
- Finished custom pockets
- Machining for special applications

NOTE: Specifications subject to change without prior notice.



HF Quick-Change H-Style Frame & Companion Insert Molds

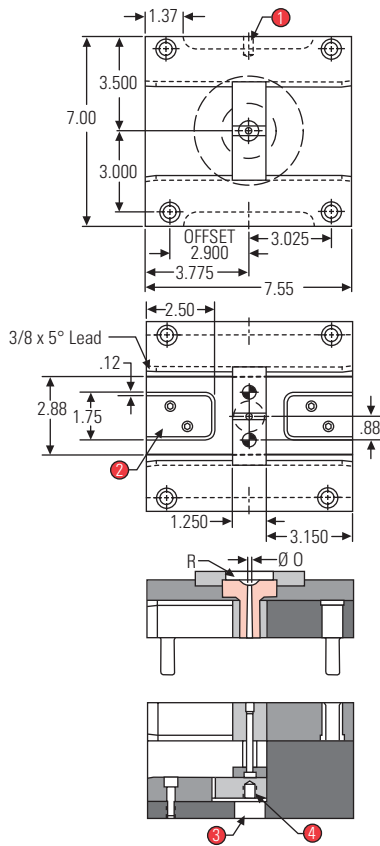
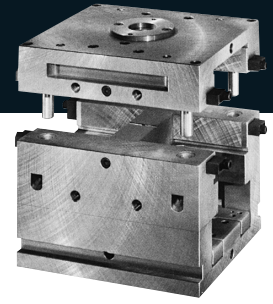

- 1 3/8-16 handling holes supplied standard as shown.
- 2 Cutout in ejector plate to accommodate pillar post supplied standard as shown.
- 3 1 1/8 diameter knockout supplied standard at center.
- 4 1/2-13 THD at knockout locations standard as shown.
- 5 Locking locating ring supplied standard as shown.

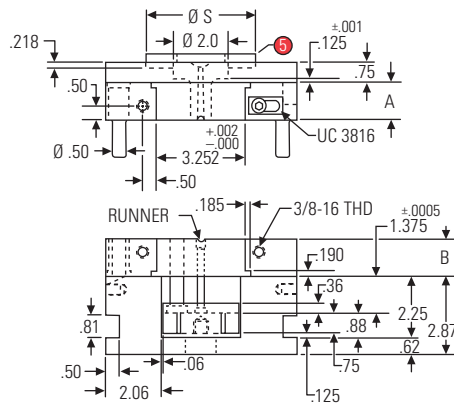

"H" Style Quick-Change Frame

ITEM NO.	A	B
07/07 HF 321	1.377	1.377
07/07 HF 322	1.877	1.377
07/07 HF 323	1.877	1.877
07/07 HF 324	2.377	1.877

Ordering and installing information for H frame and companion insert molds can be found in the front of this section.

See front of this section for standard and optional frame features.

Companion Interchangeable Insert Molds

- 1 Frame clamps at this end of insert mold and ejector plates are flush with this end.
- 2 Support post not supplied. Grind +.001 to +.002 higher than height of ejection (see page C 131).
- 3 Thicker plate optional (quotation on request).

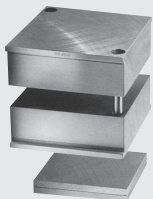

Standard Solid Construction

ITEM NO.	A	B
07/07 SSH 221	1.377	1.377
07/07 SSH 222	1.877	1.377
07/07 SSH 223	1.877	1.877
07/07 SSH 224	2.377	1.877

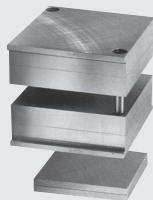

Standard Laminated Construction

ITEM NO.	A	A2	B2	B
07/07 SLH 281	1.377	0.877	0.877	1.377
07/07 SLH 282	1.877	1.377	0.877	1.377
07/07 SLH 283	1.877	1.377	1.377	1.877
07/07 SLH 284	2.377	1.877	1.377	1.877

Standard Solid: 3.25 x 3.15

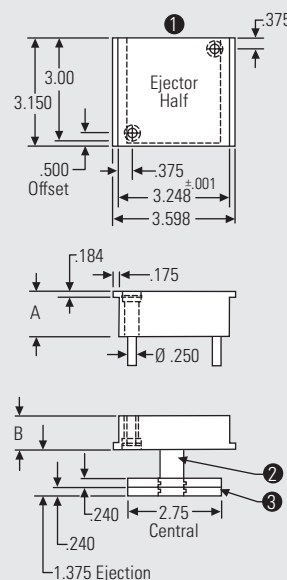

Standard Laminated: 3.25 x 3.15

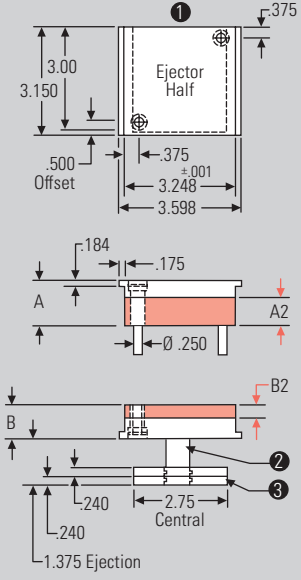

HF Quick-Change H-Style Frame & Companion Insert Molds

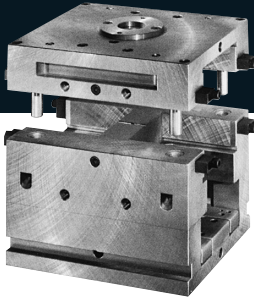

- ① 1/2-13 handling holes supplied standard as shown.
- ② Waterlines in center sections optional (quotation on request).
- ③ Cutout in ejector plate to accommodate pillar post supplied standard as shown.
- ④ 1 1/8 diameter knockouts supplied standard at center.
- ⑤ 1/2-13 THD at knockout locations standard as shown.
- ⑥ Positive ejector plate guidance.
- ⑦ Locking locating ring supplied standard as shown.

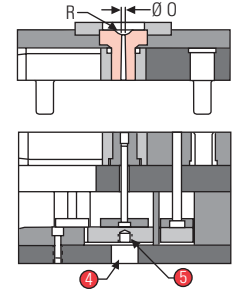
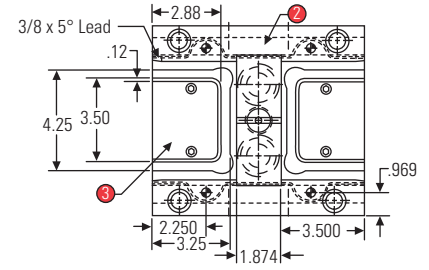
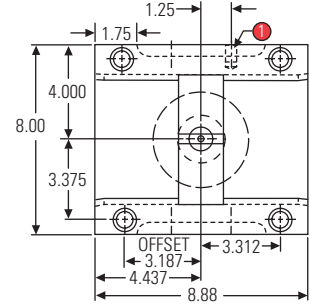

"H" Style Quick-Change Frame

ITEM NO.	A	B
08/09 HF 321	1.877	1.377
08/09 HF 322	1.877	1.877
08/09 HF 323	2.377	1.877

Ordering and installing information for H frame and companion insert molds can be found in the front of this section.

See front of this section for standard and optional frame

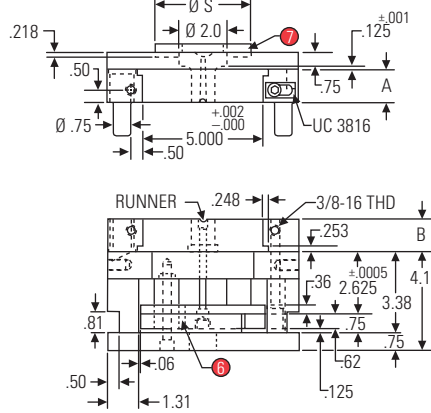

Companion Interchangeable Insert Molds

- ① Frame clamps at this end of insert mold and ejector plates are flush with this end of insert.
- ② Support post not supplied. Grind +.001 to +.002 higher than height of ejection (see page C 131).
- ③ Thicker plate optional (quotation on request).

Standard Solid:
5.0 x 3.5

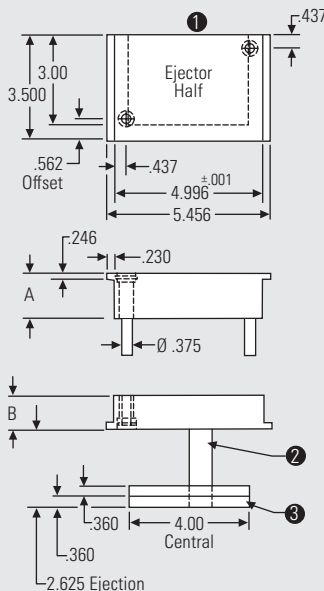

Standard Laminated:
5.0 x 3.5

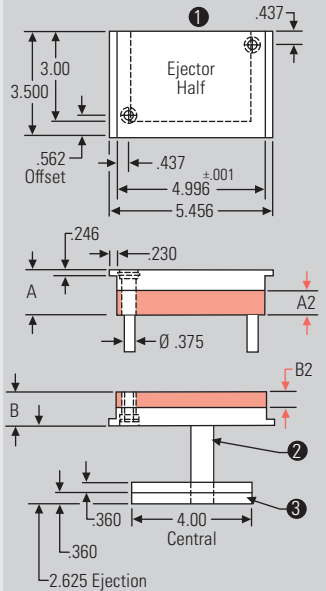

Standard Solid Construction

ITEM NO.	A	B
08/09 SSH 221	1.877	1.377
08/09 SSH 222	1.877	1.877
08/09 SSH 223	2.377	1.877

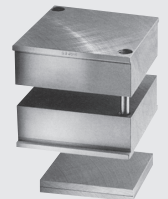

Standard Laminated Construction

ITEM NO.	A	A2	B2	B
08/09 SLH 281	1.877	0.877	0.877	1.377
08/09 SLH 282	1.877	0.877	0.877	1.877
08/09 SLH 283	2.377	1.377	0.877	1.877

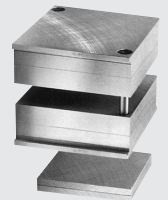

HF Quick-Change H-Style Frame & Companion Insert Molds

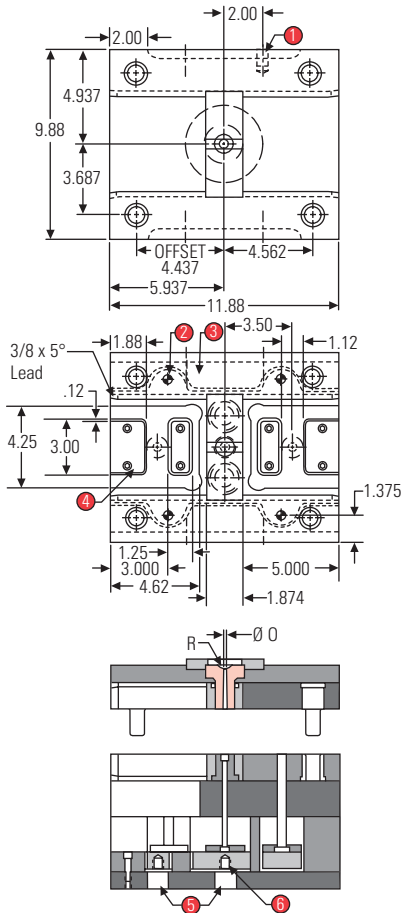
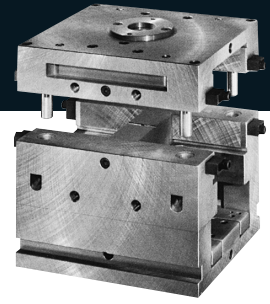

- 1 5/8-11 handling holes supplied standard as shown.
- 2 Ejector system designed for spring loading (quotation on request).
- 3 Waterlines in center sections optional (quotation on request).
- 4 Cutout in ejector plate to accommodate pillar post supplied standard as shown.
- 5 1 1/8 diameter knockouts supplied standard at center and 3.50 off center.
- 6 1/2-13 THD at knockout locations standard as shown.
- 7 Positive ejector plate guidance.
- 8 Locking locating ring supplied standard as shown.

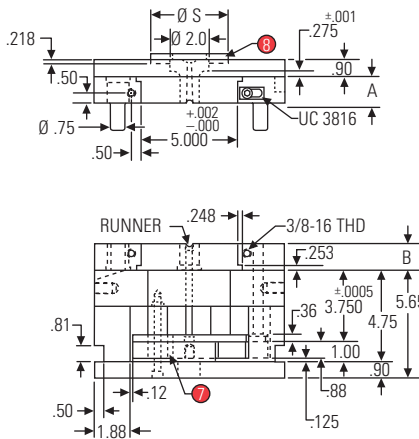

"H" Style Quick-Change Frame

ITEM NO.	A	B
10/12 HF 321	1.877	1.377
10/12 HF 322	1.877	1.877
10/12 HF 323	1.877	2.377
10/12 HF 324	2.377	1.877
10/12 HF 325	2.377	2.377

Ordering and installing information for H frame and companion insert molds can be found in the front of this section.

See front of this section for standard and optional frame

MUD® Quick-Change Mold Frames and Inserts for H-Style | 10/12 HF

Companion Interchangeable Insert Molds

- 1 Frame clamps at this end of insert mold and ejector plates are flush with this end of insert.
- 2 Support post not supplied. Grind +.001 to +.002 higher than height of ejection (see page C 131).
- 3 Thicker plate optional (quotation on request).

Standard Solid Construction

ITEM NO.	A	B
10/12 SSH 221	1.877	1.377
10/12 SSH 222	1.877	1.877
10/12 SSH 223	1.877	2.377
10/12 SSH 224	2.377	1.877
10/12 SSH 225	2.377	2.377

Standard Laminated Construction

ITEM NO.	A	A2	B2	B
10/12 SLH 281	1.877	0.877	0.877	1.377
10/12 SLH 282	1.877	0.877	0.877	1.877
10/12 SLH 283	1.877	0.877	1.377	2.377
10/12 SLH 284	2.377	1.377	0.877	1.877
10/12 SLH 285	2.377	1.377	1.377	2.377

Standard Solid: 5.0 x 5.0

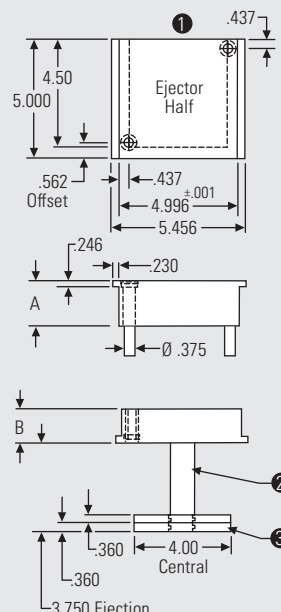

Standard Laminated: 5.0 x 5.0

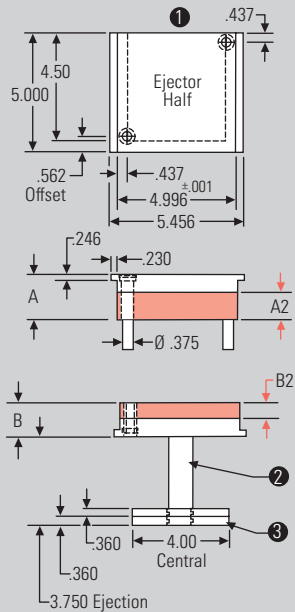

HF Quick-Change H-Style Frame & Companion Insert Molds

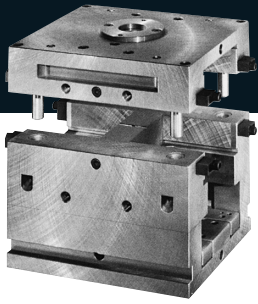

- 1 3/4-10 handling holes supplied standard as shown.
- 2 Ejector system designed for spring loading (quotation on request).
- 3 Waterlines in center sections optional (quotation on request).
- 4 Cutout in ejector plate to accommodate pillar post supplied standard as shown.
- 5 1 1/8 diameter knockouts supplied standard at center and 3.50 off center.
- 6 1/2-13 THD at knockout locations standard as shown.
- 7 Positive ejector plate guidance.
- 8 Locking locating ring supplied standard as shown.

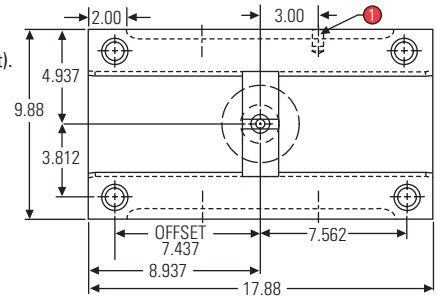

"H" Style Quick-Change Frame

ITEM NO.	A	B
10/18 HF 321	1.877	1.377
10/18 HF 322	1.877	1.877
10/18 HF 323	1.877	2.377
10/18 HF 324	2.377	1.877
10/18 HF 325	2.377	2.377
10/18 HF 326	2.377	2.877
10/18 HF 327	2.877	2.377
10/18 HF 328	2.877	2.877

Ordering and installing information for H frame and companion insert molds can be found in the front of this section.

See front of this section for standard and optional frame

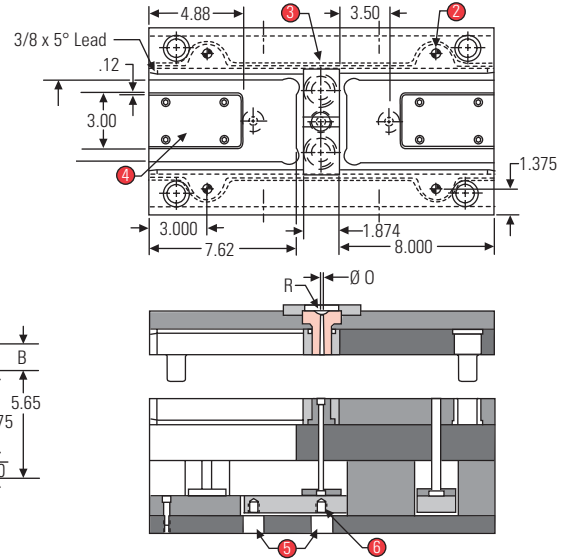
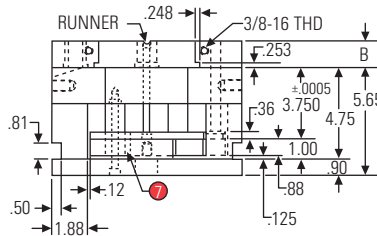
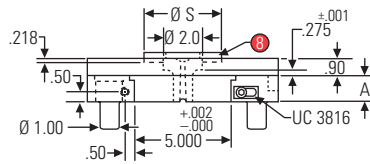

Companion Interchangeable Insert Molds

- 1 Frame clamps at this end of insert mold and ejector plates are flush with this end of insert.
- 2 Support post not supplied. Grind +.001 to +.002 higher than height of ejection (see page C 131).
- 3 Thicker plate optional (quotation on request).

Standard Solid:
5.0 x 8.0

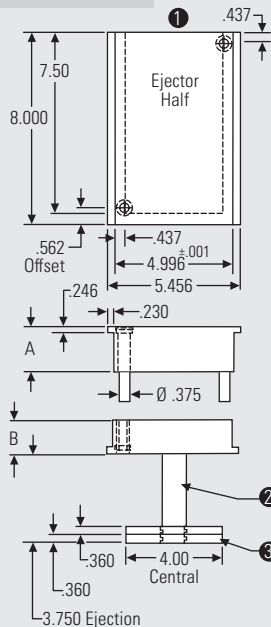

Standard Laminated:
5.0 x 8.0

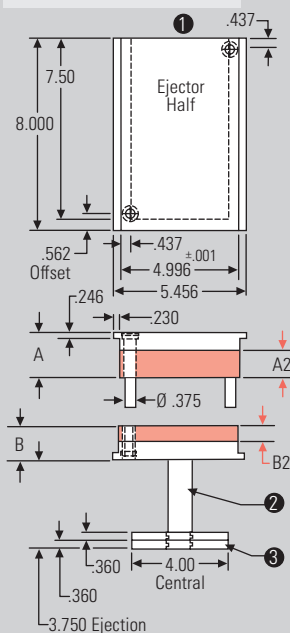

Standard Solid Construction

ITEM NO.	A	B
10/18 SSH 221	1.877	1.377
10/18 SSH 222	1.877	1.877
10/18 SSH 223	1.877	2.377
10/18 SSH 224	2.377	1.877
10/18 SSH 225	2.377	2.377
10/18 SSH 226	2.377	2.877
10/18 SSH 227	2.877	2.377
10/18 SSH 228	2.877	2.877



Standard Laminated Construction

ITEM NO.	A	A2	B2	B
10/18 SLH 281	1.877	0.877	0.877	1.377
10/18 SLH 282	1.877	0.877	0.877	1.877
10/18 SLH 283	1.877	0.877	1.377	2.377
10/18 SLH 284	2.377	1.377	0.877	1.877
10/18 SLH 285	2.377	1.377	1.377	2.377
10/18 SLH 286	2.377	1.377	1.877	2.877
10/18 SLH 287	2.877	1.877	1.377	2.377
10/18 SLH 288	2.877	1.877	1.877	2.877

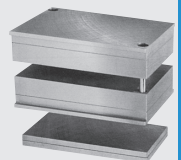

HF Quick-Change H-Style Frame & Companion Insert Molds

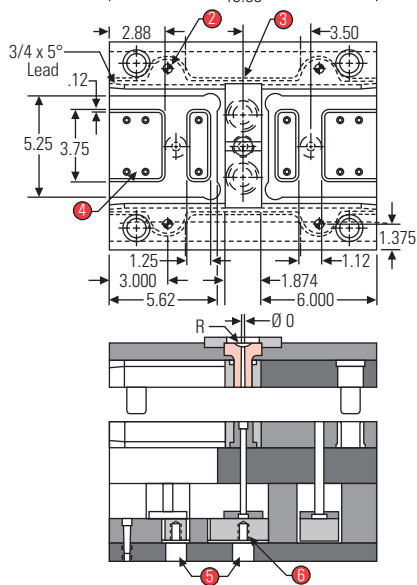
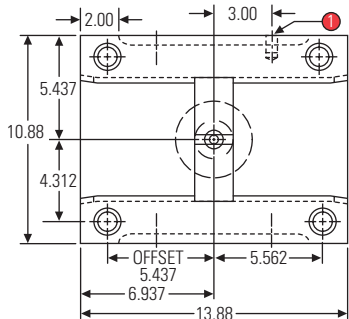
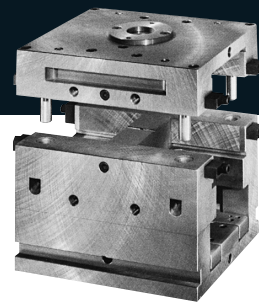

- 1 5/8-11 handling holes supplied standard as shown.
- 2 Ejector system designed for spring loading (quotation on request).
- 3 Waterlines in center sections optional (quotation on request).
- 4 Cutout in ejector plate to accommodate pillar post supplied standard as shown.
- 5 1 1/8 diameter knockouts supplied standard at center and 3.50 off center.
- 6 1/2-13 THD at knockout locations standard as shown.
- 7 Positive ejector plate guidance.
- 8 Locking locating ring supplied standard as shown.

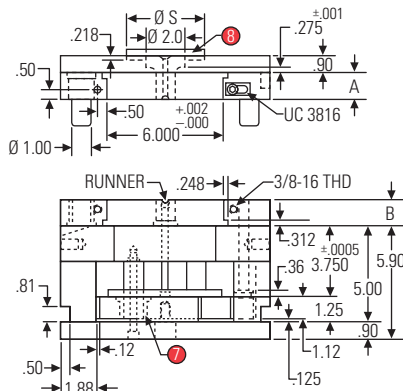

"H" Style Quick-Change Frame

ITEM NO.	A	B
11/14 HF 321	1.877	1.377
11/14 HF 322	1.877	1.877
11/14 HF 323	2.377	1.877
11/14 HF 324	2.377	2.377
11/14 HF 325	2.877	2.377
11/14 HF 326	2.877	2.877

Ordering and installing information for H frame and companion insert molds can be found in the front of this section.

See front of this section for standard and optional frame

Companion Interchangeable Insert Molds

- 1 Frame clamps at this end of insert mold and ejector plates are flush with this end of insert.
- 2 Support post not supplied. Grind +.001 to +.002 higher than height of ejection (see page C 131).
- 3 Thicker plate optional (quotation on request).

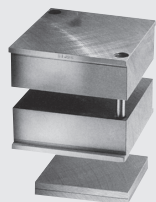

Standard Solid Construction

ITEM NO.	A	B
11/14 SSH 221	1.877	1.377
11/14 SSH 222	1.877	1.877
11/14 SSH 223	2.377	1.877
11/14 SSH 224	2.377	2.377
11/14 SSH 225	2.877	2.377
11/14 SSH 226	2.877	2.877

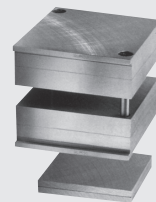

Standard Laminated Construction

ITEM NO.	A	A2	B2	B
11/14 SLH 282	1.877	0.877	0.877	1.877
11/14 SLH 283	2.377	1.377	0.877	1.877
11/14 SLH 284	2.377	1.377	1.377	2.377
11/14 SLH 285	2.877	1.877	1.377	2.377
11/14 SLH 286	2.877	1.877	1.877	2.877

Standard Solid: 6.0 x 6.0

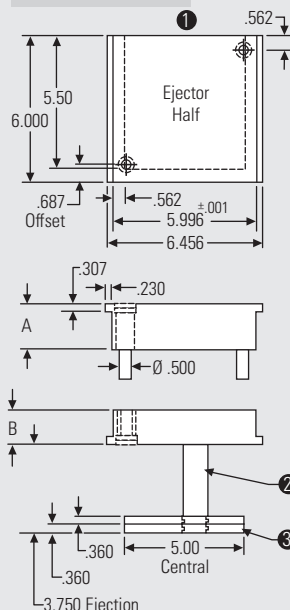

Standard Laminated: 6.0 x 6.0

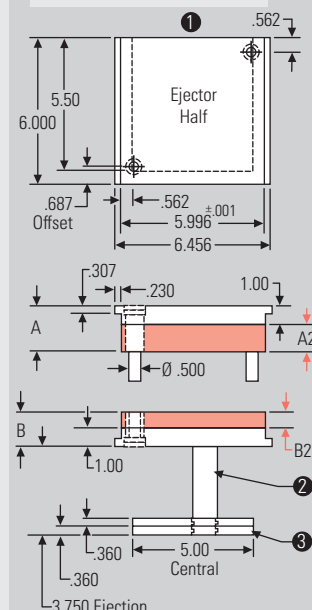

HF Quick-Change H-Style Frame & Companion Insert Molds

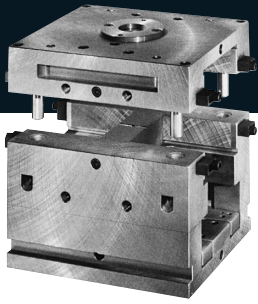

- 1 5/8-11 handling holes supplied standard as shown.
- 2 Ejector system designed for spring loading (quotation on request).
- 3 Waterlines in center sections optional (quotation on request).
- 4 Cutout in ejector plate to accommodate pillar post supplied standard as shown.
- 5 1 1/8 diameter knockouts supplied standard at center and 3.50 off center.
- 6 1/2-13 THD at knockout locations standard as shown.
- 7 Positive ejector plate guidance.
- 8 Locking locating ring supplied standard as shown.

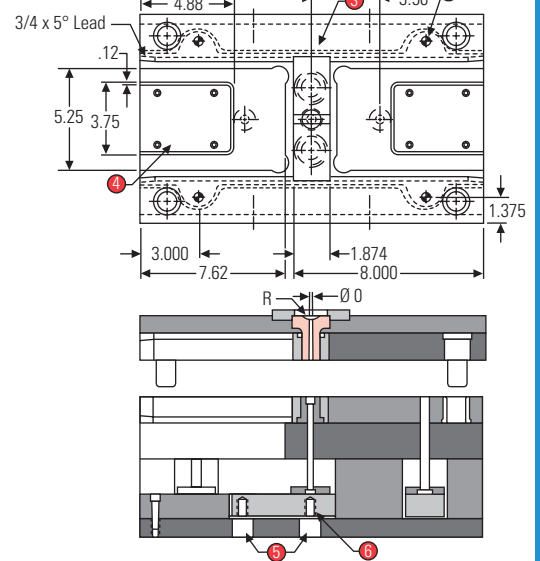
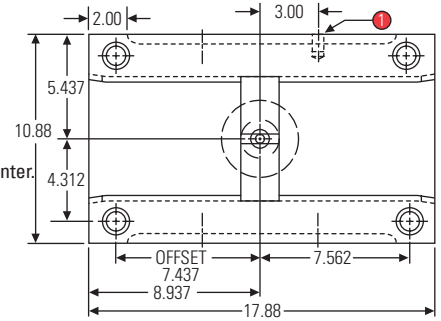

"H" Style Quick-Change Frame

ITEM NO.	A	B
11/18 HF 321	1.877	1.877
11/18 HF 322	2.377	1.877
11/18 HF 323	2.377	2.377
11/18 HF 324	2.877	2.377
11/18 HF 325	2.877	2.877

Ordering and installing information for H frame and companion insert molds can be found in the front of this section.

See front of this section for standard and optional frame

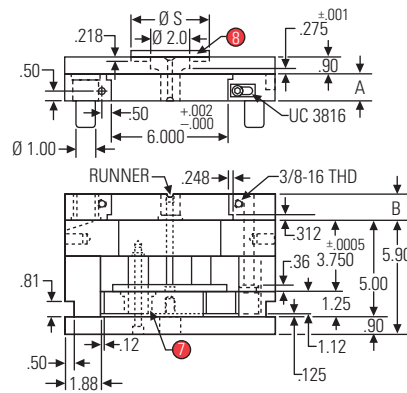

Companion Interchangeable Insert Molds

- 1 Frame clamps at this end of insert mold and ejector plates are flush with this end of insert.
- 2 Support post not supplied. Grind +.001 to +.002 higher than height of ejection (see page C 131).
- 3 Thicker plate optional (quotation on request).

Standard Solid: 6.0 x 8.0

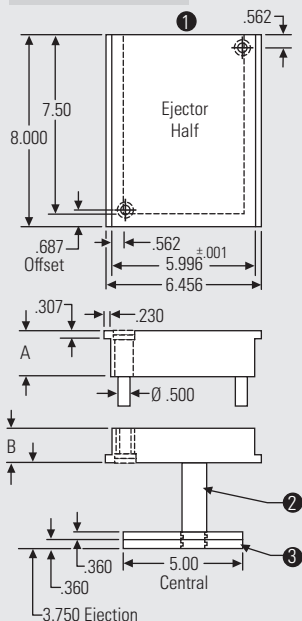

Standard Laminated: 6.0 x 8.0

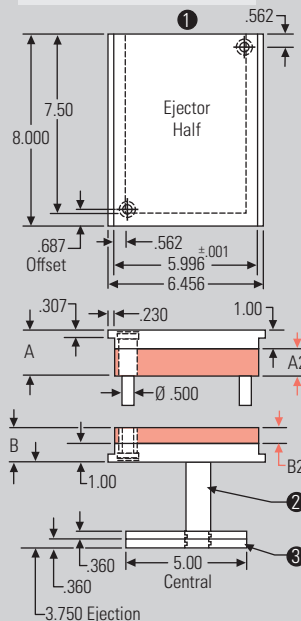

Standard Solid Construction

ITEM NO.	A	B
11/18 SSH 221	1.877	1.877
11/18 SSH 222	2.377	1.877
11/18 SSH 223	2.377	2.377
11/18 SSH 224	2.877	2.377
11/18 SSH 225	2.877	2.877

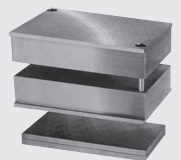

Standard Laminated Construction

ITEM NO.	A	A2	B2	B
11/18 SLH 281	1.877	0.877	0.877	1.877
11/18 SLH 282	2.377	1.377	0.877	1.877
11/18 SLH 283	2.377	1.377	1.377	2.377
11/18 SLH 284	2.877	1.877	1.377	2.377
11/18 SLH 285	2.877	1.877	1.877	2.877

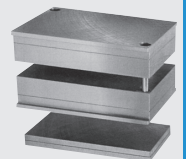

HF Quick-Change H-Style Frame & Companion Insert Molds

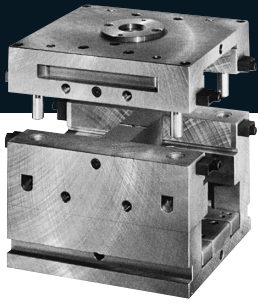

- 1 5/8-11 handling holes supplied standard as shown.
- 2 Ejector system designed for spring loading (quotation on request).
- 3 Waterlines in center sections optional (quotation on request).
- 4 Cutout in ejector plate to accommodate pillar post supplied standard as shown.
- 5 1 1/8 diameter knockouts supplied standard at center and 3.50 off center.
- 6 1/2-13 THD at knockout locations standard as shown.
- 7 Positive ejector plate guidance.
- 8 Locking locating ring supplied standard as shown.

"H" Style Quick-Change Frame

ITEM NO.	A	B
12/13 HF 321	1.877	1.877
12/13 HF 322	1.877	2.377
12/13 HF 323	2.377	1.877
12/13 HF 324	2.377	2.377

Ordering and installing information for H frame and companion insert molds can be found in the front of this section.

See front of this section for standard and optional frame

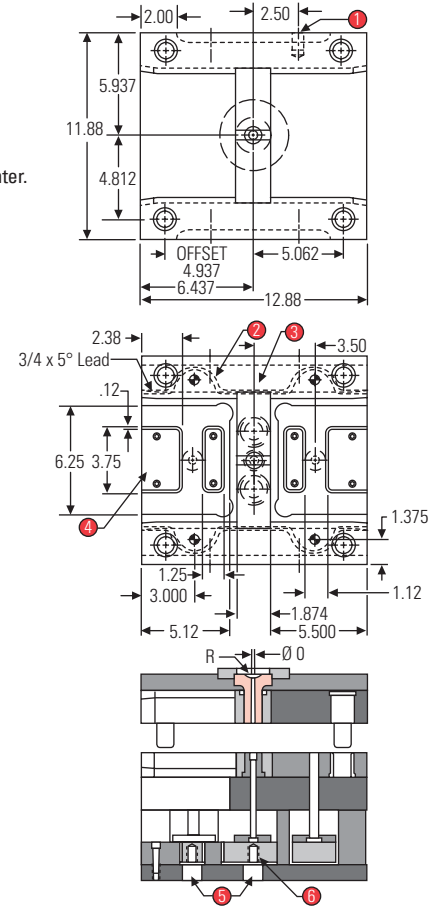
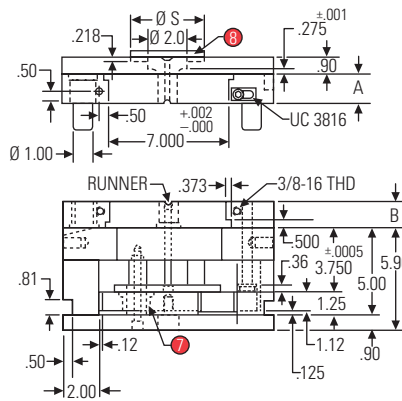

Companion Interchangeable Insert Molds

- 1 Frame clamps this end of insert mold and ejector plates are flush with this end of insert.
- 2 Support post not supplied. Grind +.001 to +.002 higher than height of ejection (see page C 131).
- 3 Thicker plate optional (quotation on request).
- 4 3/4 x 5° lead this end.

Standard Solid:
7.0 x 5.5

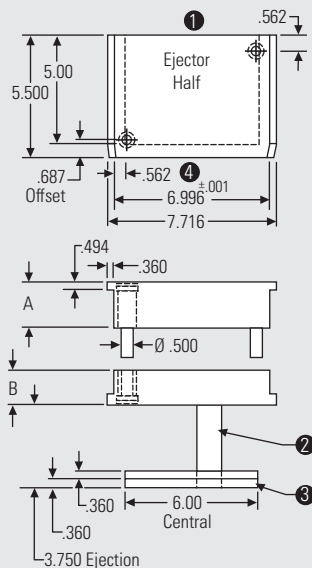

Standard Laminated:
7.0 x 5.5

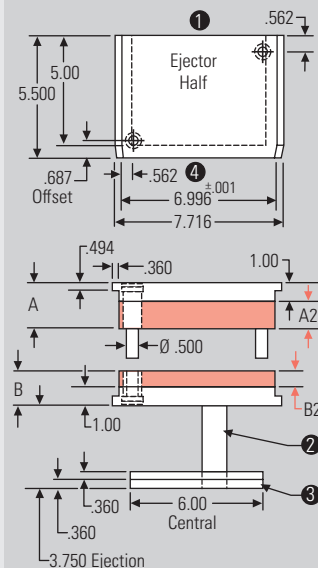

Standard Solid Construction

ITEM NO.	A	B
12/13 SSH 221	1.877	1.877
12/13 SSH 222	1.877	2.377
12/13 SSH 223	2.377	1.877
12/13 SSH 224	2.377	2.377

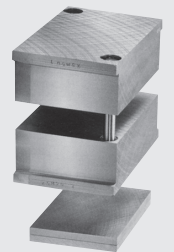

Standard Laminated Construction

ITEM NO.	A	A2	B2	B
12/13 SLH 281	1.877	0.877	0.877	1.877
12/13 SLH 282	1.877	0.877	1.377	2.377
12/13 SLH 283	2.377	1.377	0.877	1.877
12/13 SLH 284	2.377	1.377	1.377	2.377

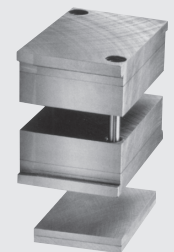

MUD® Quick-Change Mold Frames and Inserts for H-Style | 12/13 HF



HF Quick-Change H-Style Frame & Companion Insert Molds

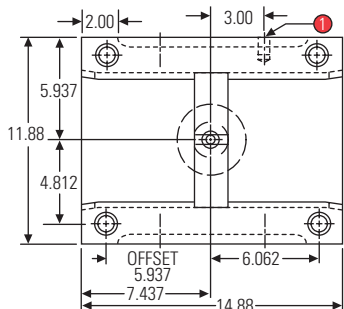
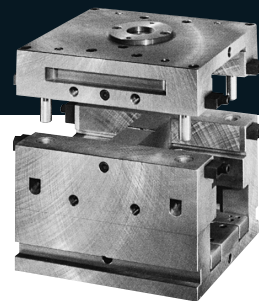

- 1 5/8-11 handling holes supplied standard as shown.
- 2 Ejector system designed for spring loading (quotation on request).
- 3 Waterlines in center sections optional (quotation on request).
- 4 Cutout in ejector plate to accommodate pillar post supplied standard as shown.
- 5 1 1/8 diameter knockouts supplied standard at center and 3.50 off center.
- 6 1/2-13 THD at knockout locations standard as shown.
- 7 Positive ejector plate guidance.
- 8 Locking locating ring supplied standard as shown.

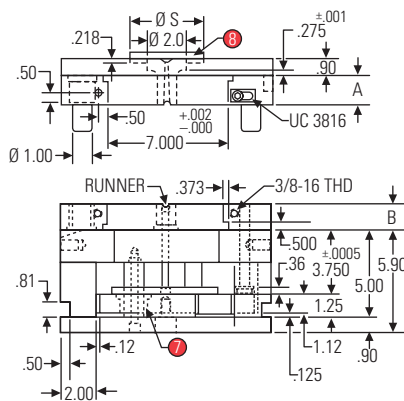
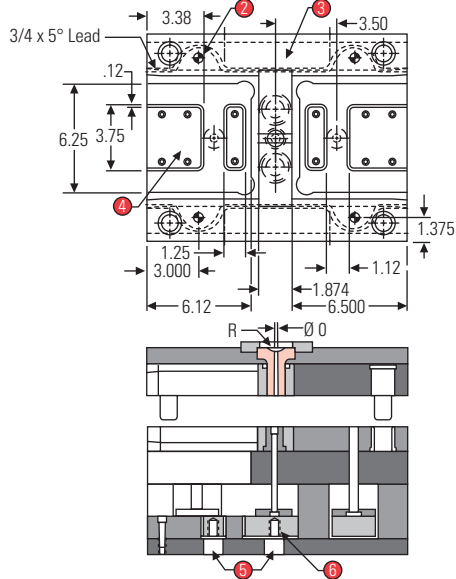

"H" Style Quick-Change Frame

ITEM NO.	A	B
12/15 HF 321	1.877	1.877
12/15 HF 322	1.877	2.377
12/15 HF 323	2.377	1.877
12/15 HF 324	2.377	2.377

Ordering and installing information for H frame and companion insert molds can be found in the front of this section.

See front of this section for standard and optional frame

Companion Interchangeable Insert Molds

- 1 Frame clamps at this end of insert mold and ejector plates are flush with this end of insert.
- 2 Support post not supplied. Grind +.001 to +.002 higher than height of ejection (see page C 131).
- 3 Thicker plate optional (quotation on request).
- 4 3/4 x 5° lead this end.

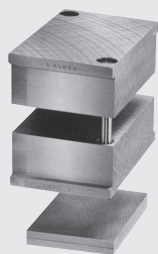

Standard Solid Construction

ITEM NO.	A	B
12/15 SSH 221	1.877	1.877
12/15 SSH 222	1.877	2.377
12/15 SSH 223	2.377	1.877
12/15 SSH 224	2.377	2.377

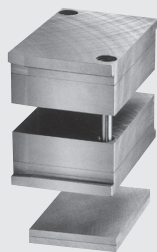

Standard Laminated Construction

ITEM NO.	A	A2	B2	B
12/15 SLH 281	1.877	0.877	0.877	1.877
12/15 SLH 282	1.877	0.877	1.377	2.377
12/15 SLH 283	2.377	1.377	0.877	1.877
12/15 SLH 284	2.377	1.377	1.377	2.377

Standard Solid: 7.0 x 6.5

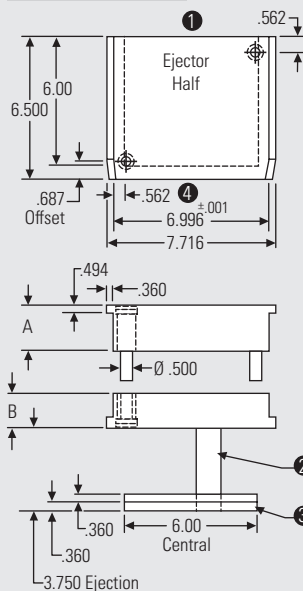

Standard Laminated: 7.0 x 6.5

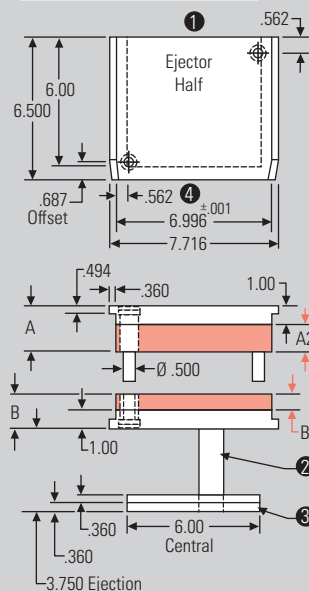

HF Quick-Change H-Style Frame & Companion Insert Molds

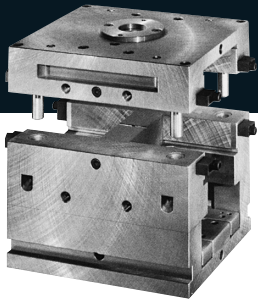

- 1 5/8-11 handling holes supplied standard as shown.
- 2 Ejector system designed for spring loading (quotation on request).
- 3 Waterlines in center sections optional (quotation on request).
- 4 Cutout in ejector plate to accommodate pillar post supplied standard as shown.
- 5 1 1/8 diameter knockouts supplied standard at center and 3.50 off center.
- 6 1/2-13 THD at knockout locations standard as shown.
- 7 Positive ejector plate guidance.
- 8 Locking locating ring supplied standard as shown.

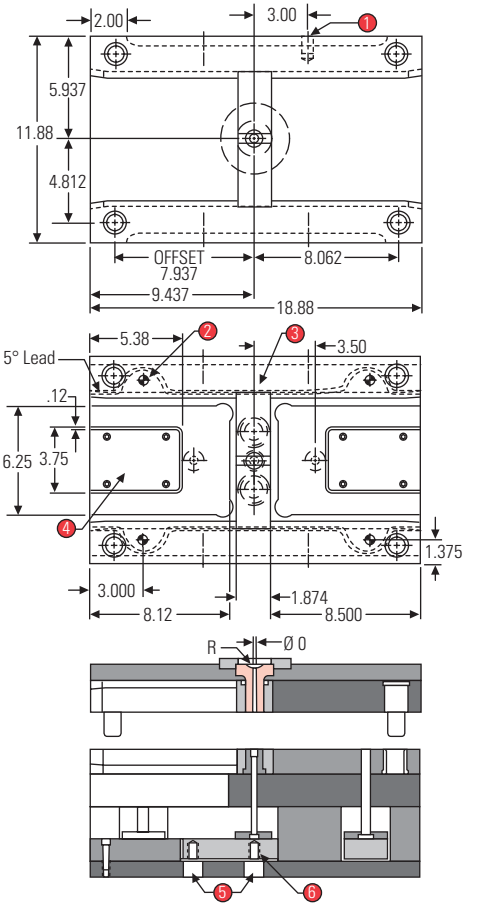

"H" Style Quick-Change Frame

ITEM NO.	A	B
12/19 HF 321	1.877	1.877
12/19 HF 322	1.877	2.377
12/19 HF 323	2.377	1.877
12/19 HF 324	2.377	2.377

Ordering and installing information for H frame and companion insert molds can be found in the front of this section.

See front of this section for standard and optional frame

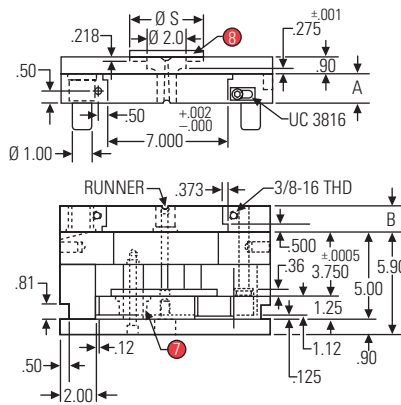

Companion Interchangeable Insert Molds

- 1 Frame clamps at this end of insert mold and ejector plates are flush with this end of insert.
- 2 Support post not supplied. Grind +.001 to +.002 higher than height of ejection (see page C 131).
- 3 Thicker plate optional (quotation on request).
- 4 3/4 x 5° lead this end.

Standard Solid:
7.0 x 8.5

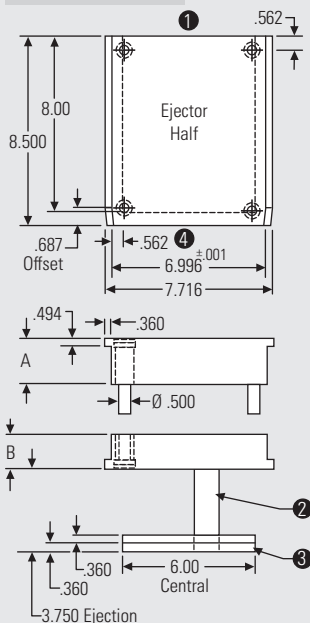

Standard Laminated:
7.0 x 8.5

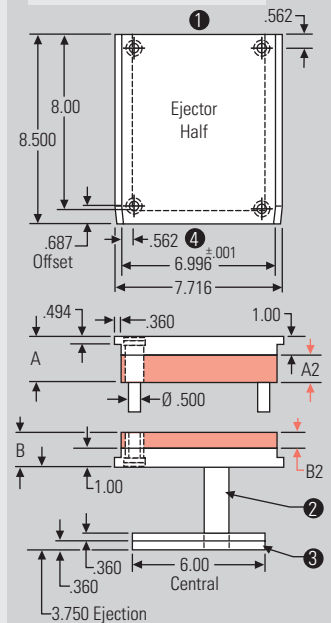

Standard Solid Construction

ITEM NO.	A	B
12/19 SSH 221	1.877	1.877
12/19 SSH 222	1.877	2.377
12/19 SSH 223	2.377	1.877
12/19 SSH 224	2.377	2.377

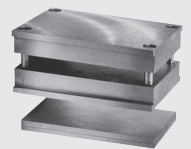

Standard Laminated Construction

ITEM NO.	A	A2	B2	B
12/19 SLH 281	1.877	0.877	0.877	1.877
12/19 SLH 282	1.877	0.877	1.377	2.377
12/19 SLH 283	2.377	1.377	0.877	1.877
12/19 SLH 284	2.377	1.377	1.377	2.377

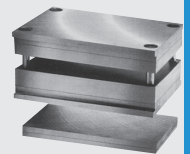

MUD® Quick-Change Mold Frames and Inserts for H-Style | 12/19 HF



HF Quick-Change H-Style Frame & Companion Insert Molds

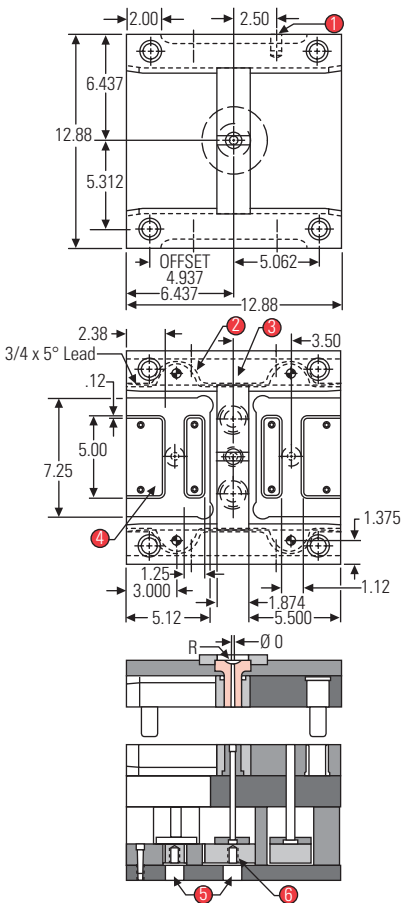
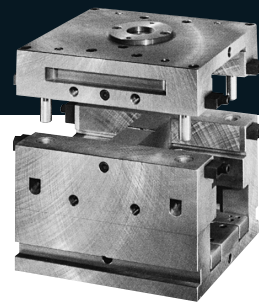

- 1 3/4-10 handling holes supplied standard as shown.
- 2 Ejector system designed for spring loading (quotation on request).
- 3 Waterlines in center sections optional (quotation on request).
- 4 Cutout in ejector plate to accommodate pillar post supplied standard as shown.
- 5 1 1/8 diameter knockouts supplied standard at center and 3.50 off center.
- 6 1/2-13 THD at knockout locations standard as shown.
- 7 Positive ejector plate guidance.
- 8 Locking locating ring supplied standard as shown.

"H" Style Quick-Change Frame

ITEM NO.	A	B
13/13 HF 321	1.877	1.877
13/13 HF 322	1.877	2.377
13/13 HF 323	2.377	1.877
13/13 HF 324	2.377	2.377
13/13 HF 325	2.377	2.877
13/13 HF 326	2.877	2.377
13/13 HF 327	2.877	2.877

Ordering and installing information for H frame and companion insert molds can be found in the front of this section.

See front of this section for standard and optional frame

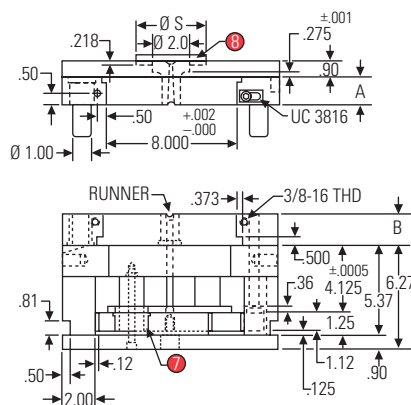

Companion Interchangeable Insert Molds

- 1 Frame clamps at this end of insert mold and ejector plates are flush with this end of insert.
- 2 Support post not supplied. Grind +.001 to +.002 higher than height of ejection (see page C 131).
- 3 Thicker plate optional (quotation on request).
- 4 3/4 x 5° lead this end.

Standard Solid Construction

ITEM NO.	A	B
13/13 SSH 221	1.877	1.877
13/13 SSH 222	1.877	2.377
13/13 SSH 223	2.377	1.877
13/13 SSH 224	2.377	2.377
13/13 SSH 225	2.377	2.877
13/13 SSH 226	2.877	2.377
13/13 SSH 227	2.877	2.877

Standard Laminated Construction

ITEM NO.	A	A2	B2	B
13/13 SLH 281	1.877	0.877	0.877	1.877
13/13 SLH 282	1.877	0.877	1.377	2.377
13/13 SLH 283	2.377	1.377	0.877	1.877
13/13 SLH 284	2.377	1.377	1.377	2.377
13/13 SLH 285	2.377	1.377	1.877	2.877
13/13 SLH 286	2.877	1.877	1.377	2.377
13/13 SLH 287	2.877	1.877	1.877	2.877

Standard Solid: 8.0 x 5.5

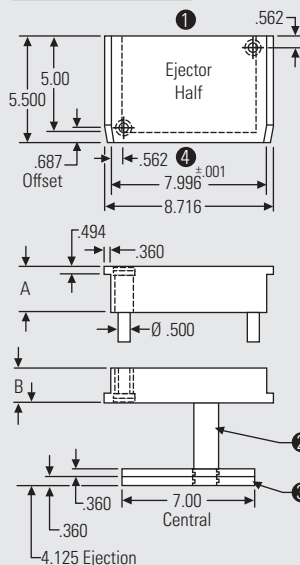

Standard Laminated: 8.0 x 5.5

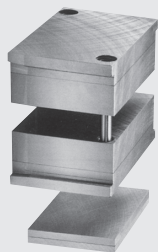
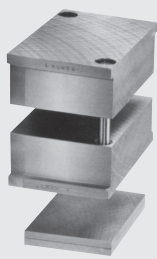
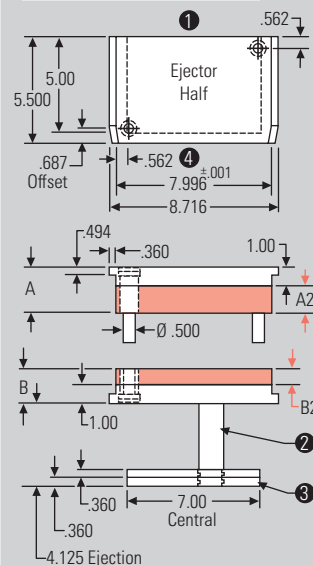

HF Quick-Change H-Style Frame & Companion Insert Molds

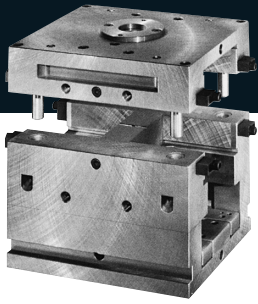

- 1 3/4-10 handling holes supplied standard as shown.
- 2 Ejector system designed for spring loading (quotation on request).
- 3 Waterlines in center sections optional (quotation on request).
- 4 Cutout in ejector plate to accommodate pillar post supplied standard as shown.
- 5 1 1/8 diameter knockouts supplied standard at center and 3.50 off center.
- 6 1/2-13 THD at knockout locations standard as shown.
- 7 Positive ejector plate guidance.
- 8 Locking locating ring supplied standard as shown.

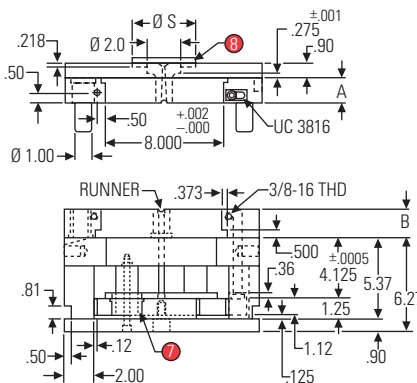
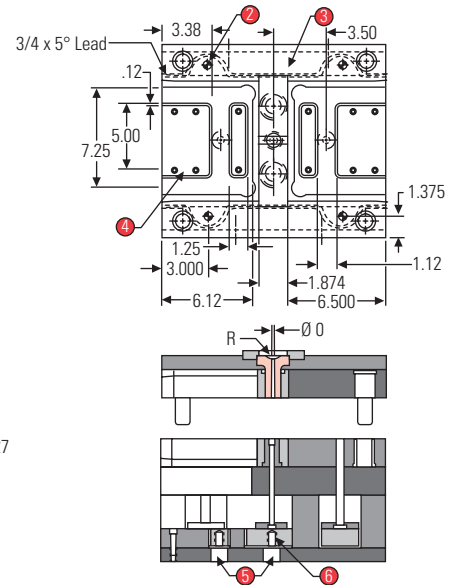
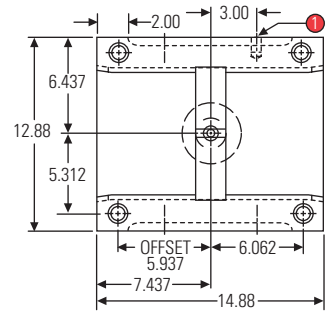

"H" Style Quick-Change Frame

ITEM NO.	A	B
13/15 HF 321	1.877	1.877
13/15 HF 322	1.877	2.377
13/15 HF 323	2.377	1.877
13/15 HF 324	2.377	2.377
13/15 HF 325	2.377	2.877
13/15 HF 326	2.877	2.377
13/15 HF 327	2.877	2.877

Ordering and installing information for H frame and companion insert molds can be found in the front of this section.

See front of this section for standard and optional frame

Companion Interchangeable Insert Molds

- 1 Frame clamps at this end of insert mold and ejector plates are flush with this end of insert.
- 2 Support post not supplied. Grind +.001 to +.002 higher than height of ejection (see page C 131).
- 3 Thicker plate optional (quotation on request).
- 4 3/4 x 5° lead this end.

Standard Solid:
8.0 x 6.5

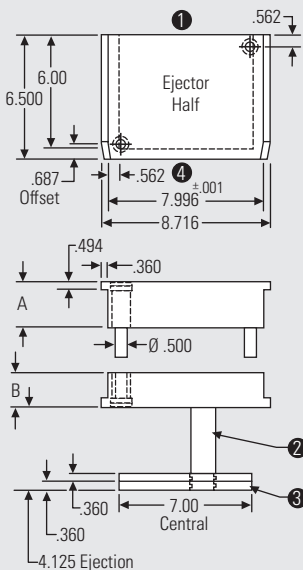

Standard Laminated:
8.0 x 6.5

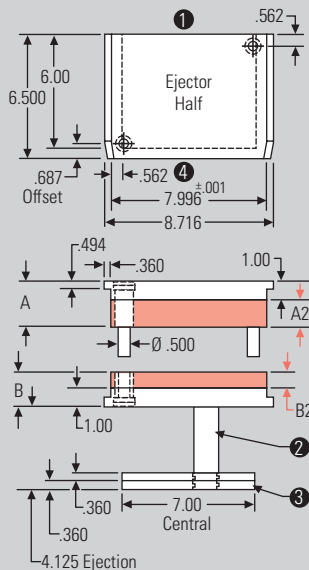

Standard Solid Construction

ITEM NO.	A	B
13/15 SSH 221	1.877	1.877
13/15 SSH 222	1.877	2.377
13/15 SSH 223	2.377	1.877
13/15 SSH 224	2.377	2.377
13/15 SSH 225	2.377	2.877
13/15 SSH 226	2.877	2.377
13/15 SSH 227	2.877	2.877

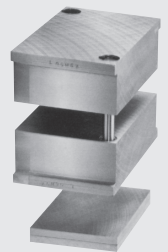

Standard Laminated Construction

ITEM NO.	A	A2	B2	B
13/15 SLH 281	1.877	0.877	0.877	1.877
13/15 SLH 282	1.877	0.877	1.377	2.377
13/15 SLH 283	2.377	1.377	0.877	1.877
13/15 SLH 284	2.377	1.377	1.377	2.377
13/15 SLH 285	2.377	1.377	1.877	2.877
13/15 SLH 286	2.877	1.877	1.377	2.377
13/15 SLH 287	2.877	1.877	1.877	2.877



MUD® Quick-Change Mold Frames and Inserts for H-Style | 13/15 HF



HF Quick-Change H-Style Frame & Companion Insert Molds

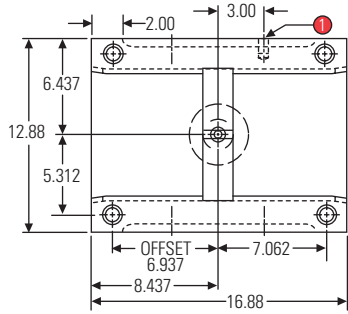
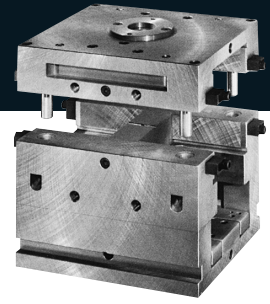

- 1 3/4-10 handling holes supplied standard as shown.
- 2 Ejector system designed for spring loading (quotation on request).
- 3 Waterlines in center sections optional (quotation on request).
- 4 Cutout in ejector plate to accommodate pillar post supplied standard as shown.
- 5 1 1/8 diameter knockouts supplied standard at center and 3.50 off center.
- 6 1/2-13 THD at knockout locations standard as shown.
- 7 Positive ejector plate guidance.
- 8 Locking locating ring supplied standard as shown.

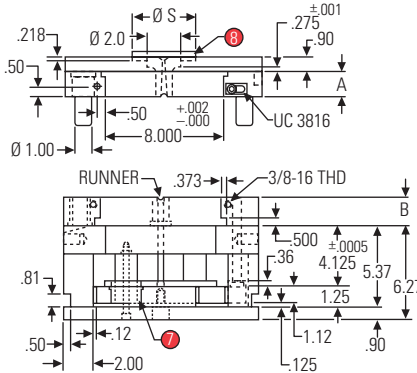
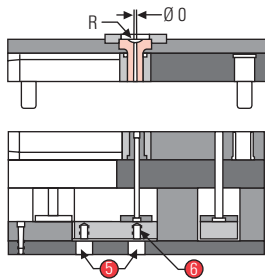
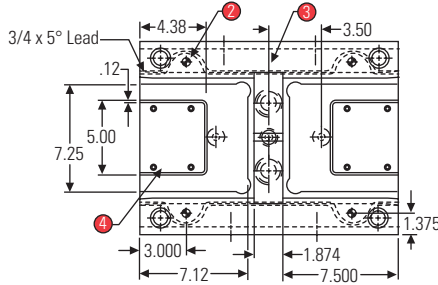

"H" Style Quick-Change Frame

ITEM NO.	A	B
13/17 HF 321	1.877	1.877
13/17 HF 322	1.877	2.377
13/17 HF 323	2.377	1.877
13/17 HF 324	2.377	2.377
13/17 HF 325	2.377	2.877
13/17 HF 326	2.877	2.377
13/17 HF 327	2.877	2.877

Ordering and installing information for H frame and companion insert molds can be found in the front of this section.

See front of this section for standard and optional frame

Companion Interchangeable Insert Molds

- 1 Frame clamps at this end of insert mold and ejector plates are flush with this end of insert.
- 2 Support post not supplied. Grind +.001 to +.002 higher than height of ejection (see page C 131).
- 3 Thicker plate optional (quotation on request).
- 4 3/4 x 5° lead this end.

Standard Solid Construction



ITEM NO.	A	B
13/17 SSH 221	1.877	1.877
13/17 SSH 222	1.877	2.377
13/17 SSH 223	2.377	1.877
13/17 SSH 224	2.377	2.377
13/17 SSH 225	2.377	2.877
13/17 SSH 226	2.877	2.377
13/17 SSH 227	2.877	2.877

Standard Laminated Construction



ITEM NO.	A	A2	B2	B
13/17 SLH 281	1.877	0.877	0.877	1.877
13/17 SLH 282	1.877	0.877	1.377	2.377
13/17 SLH 283	2.377	1.377	0.877	1.877
13/17 SLH 284	2.377	1.377	1.377	2.377
13/17 SLH 285	2.377	1.377	1.877	2.877
13/17 SLH 286	2.877	1.877	1.377	2.377
13/17 SLH 287	2.877	1.877	1.877	2.877

Standard Solid: 8.0 x 7.5

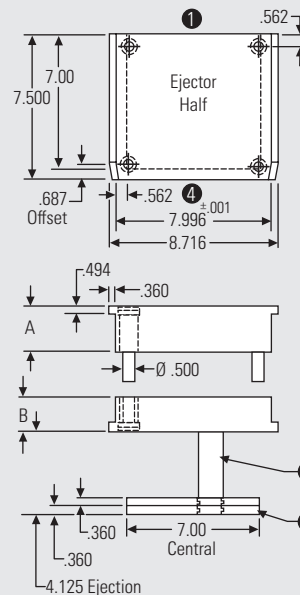

Standard Laminated: 8.0 x 7.5

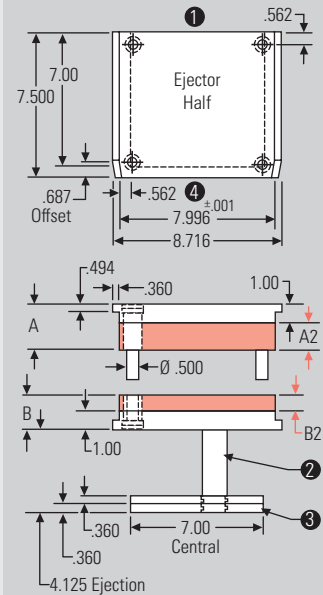

HF Quick-Change H-Style Frame & Companion Insert Molds

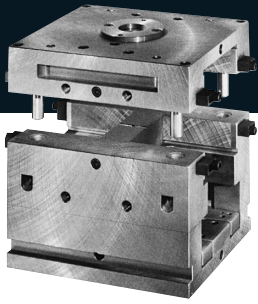

- 1 3/4-10 handling holes supplied standard as shown.
- 2 Ejector system designed for spring loading (quotation on request).
- 3 Waterlines in center sections optional (quotation on request).
- 4 Cutout in ejector plate to accommodate pillar post supplied standard as shown.
- 5 1/8 diameter knockouts supplied standard at center and 3.50 off center.
- 6 1/2-13 THD at knockout locations standard as shown.
- 7 Positive ejector plate guidance.
- 8 Locking locating ring supplied standard as shown.

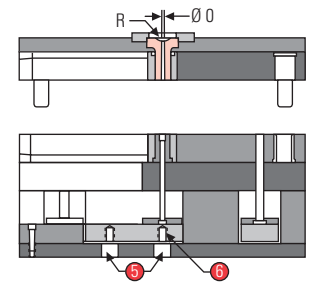
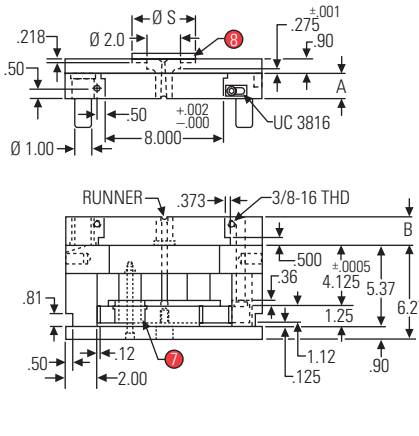
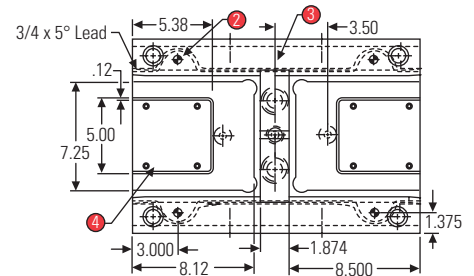
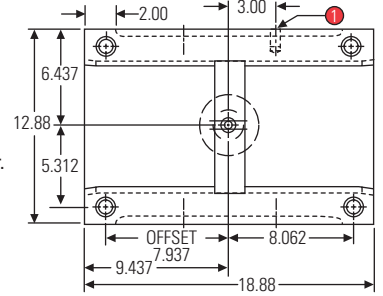

"H" Style Quick-Change Frame

ITEM NO.	A	B
13/19 HF 321	1.877	1.877
13/19 HF 322	1.877	2.377
13/19 HF 323	2.377	1.877
13/19 HF 324	2.377	2.377
13/19 HF 325	2.377	2.877
13/19 HF 326	2.877	2.377
13/19 HF 327	2.877	2.877

Ordering and installing information for H frame and companion insert molds can be found in the front of this section.

See front of this section for standard and optional frame

Companion Interchangeable Insert Molds

- 1 Frame clamps at this end of insert mold and ejector plates are flush with this end of insert.
- 2 Support post not supplied. Grind +.001 to +.002 higher than height of ejection (see page C 131).
- 3 Thicker plate optional (quotation on request).
- 4 3/4 x 5° lead this end.

Standard Solid:
8.0 x 8.5

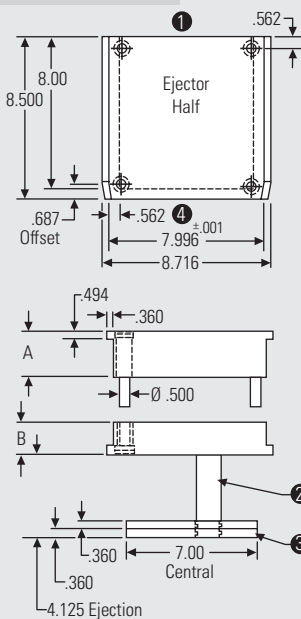

Standard Laminated:
8.0 x 8.5

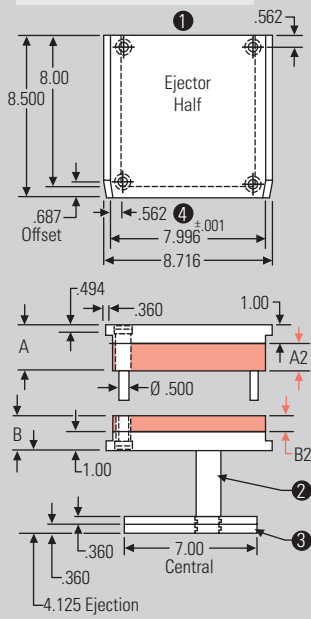

Standard Solid Construction

ITEM NO.	A	B
13/19 SSH 221	1.877	1.877
13/19 SSH 222	1.877	2.377
13/19 SSH 223	2.377	1.877
13/19 SSH 224	2.377	2.377
13/19 SSH 225	2.377	2.877
13/19 SSH 226	2.877	2.377
13/19 SSH 227	2.877	2.877

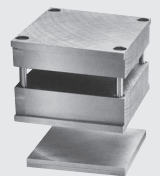

Standard Laminated Construction

ITEM NO.	A	A2	B2	B
13/19 SLH 281	1.877	0.877	0.877	1.877
13/19 SLH 282	1.877	0.877	1.377	2.377
13/19 SLH 283	2.377	1.377	0.877	1.877
13/19 SLH 284	2.377	1.377	1.377	2.377
13/19 SLH 285	2.377	1.377	1.877	2.877
13/19 SLH 286	2.877	1.877	1.377	2.377
13/19 SLH 287	2.877	1.877	1.877	2.877

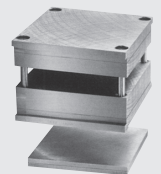

MUD® Quick-Change Mold Frames and Inserts for H-Style | 13/19 HF



HF Quick-Change H-Style Frame & Companion Insert Molds

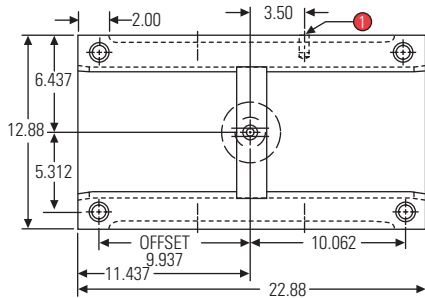
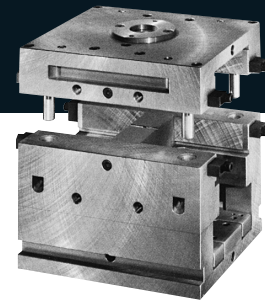

- 1 3/4-10 handling holes supplied standard as shown.
- 2 Ejector system designed for spring loading (quotation on request).
- 3 Waterlines in center sections optional (quotation on request).
- 4 Cutout in ejector plate to accommodate pillar post supplied standard as shown.
- 5 1 1/8 diameter knockouts supplied standard at center and 3.50 off center.
- 6 1/2-13 THD at knockout locations standard as shown.
- 7 Positive ejector plate guidance.
- 8 Locking locating ring supplied standard as shown.

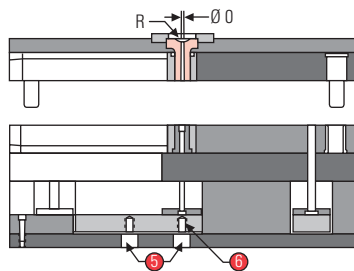
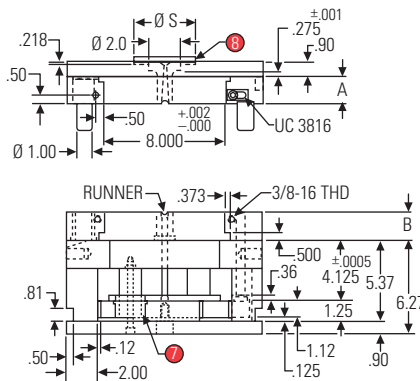
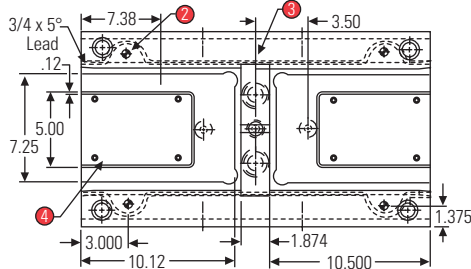

"H" Style Quick-Change Frame

ITEM NO.	A	B
13/23 HF 321	1.877	1.877
13/23 HF 322	1.877	2.377
13/23 HF 323	2.377	1.877
13/23 HF 324	2.377	2.377
13/23 HF 325	2.377	2.877
13/23 HF 326	2.877	2.377
13/23 HF 327	2.877	2.877

Ordering and installing information for H frame and companion insert molds can be found in the front of this section.

See front of this section for standard and optional frame

Companion Interchangeable Insert Molds

- 1 Frame clamps at this end of insert mold and ejector plates are flush with this end of insert.
- 2 Support post not supplied. Grind +.001 to +.002 higher than height of ejection (see page C 131).
- 3 Thicker plate optional (quotation on request).
- 4 3/4 x 5° lead this end.

Standard Solid Construction

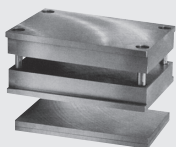

ITEM NO.	A	B
13/23 SSH 221	1.877	1.877
13/23 SSH 222	1.877	2.377
13/23 SSH 223	2.377	1.877
13/23 SSH 224	2.377	2.377
13/23 SSH 225	2.377	2.877
13/23 SSH 226	2.877	2.377
13/23 SSH 227	2.877	2.877

Standard Laminated Construction

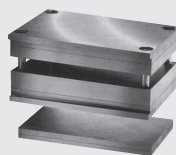

ITEM NO.	A	A2	B2	B
13/23 SLH 281	1.877	0.877	0.877	1.877
13/23 SLH 282	1.877	0.877	1.377	2.377
13/23 SLH 283	2.377	1.377	0.877	1.877
13/23 SLH 284	2.377	1.377	1.377	2.377
13/23 SLH 285	2.377	1.377	1.877	2.877
13/23 SLH 286	2.877	1.877	1.377	2.377
13/23 SLH 287	2.877	1.877	1.877	2.877

Standard Solid: 8.0 x 10.5

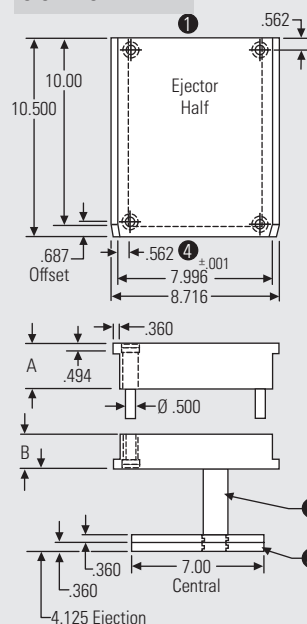

Standard Laminated: 8.0 x 10.5

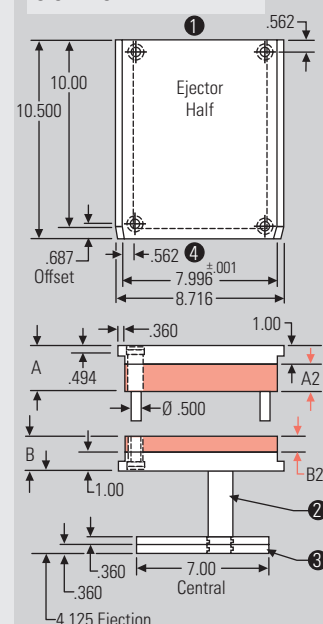

HF Quick-Change H-Style Frame & Companion Insert Molds

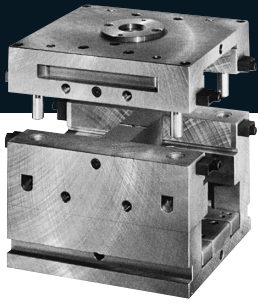

- ① 3/4-10 handling holes supplied standard as shown.
- ② Ejector system designed for spring loading (quotation on request).
- ③ Waterlines in center sections optional (quotation on request).
- ④ Cutout in ejector plate to accommodate pillar post supplied standard as shown.
- ⑤ 1 1/8 diameter knockouts supplied standard at center and 3.50 off center.
- ⑥ 1/2-13 THD at knockout locations standard as shown.
- ⑦ Positive ejector plate guidance.
- ⑧ Locking locating ring supplied standard as shown.

"H" Style Quick-Change Frame

ITEM NO.	A	B
14/15 HF 321	1.877	2.377
14/15 HF 322	2.377	1.877
14/15 HF 323	2.377	2.377
14/15 HF 324	2.377	2.877
14/15 HF 325	2.877	2.377
14/15 HF 326	2.877	2.877
14/15 HF 327	2.877	3.377
14/15 HF 328	3.377	2.877
14/15 HF 329	3.377	3.377

Ordering and installing information for H frame and companion insert molds can be found in the front of this section.

See front of this section for standard and optional frame

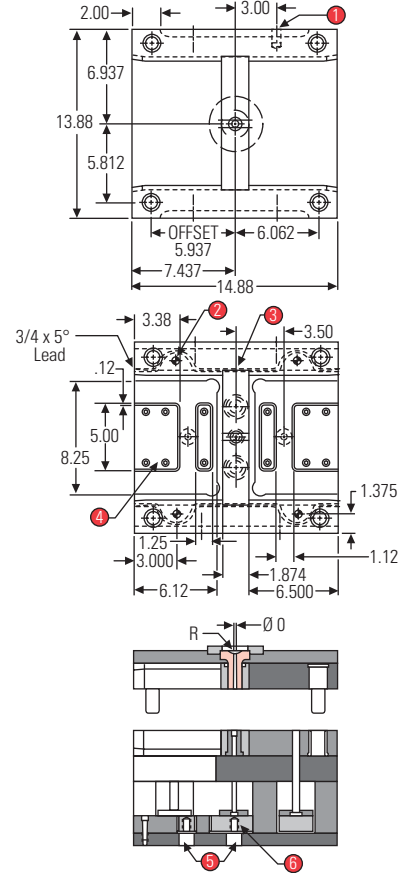
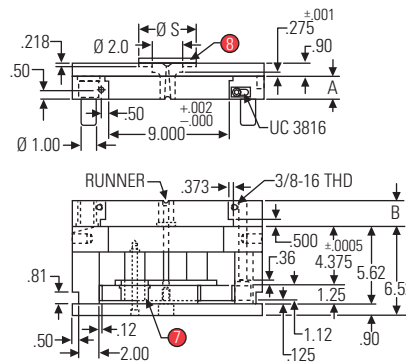

Companion Interchangeable Insert Molds

- ① Frame clamps at this end of insert mold and ejector plates are flush with this end of insert.
- ② Support post not supplied. Grind +.001 to +.002 higher than height of ejection (see page C 131).
- ③ Thicker plate optional (quotation on request).
- ④ 3/4 x 5° lead this end.

Standard Solid: 9.0 x 6.5

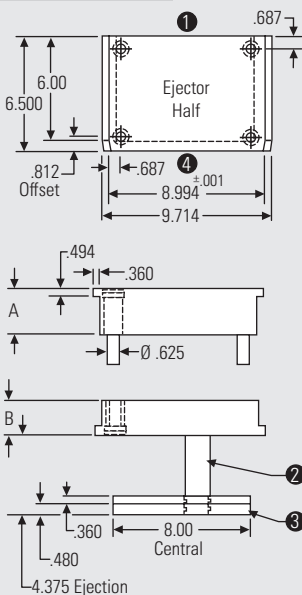

Standard Laminated: 9.0 x 6.5

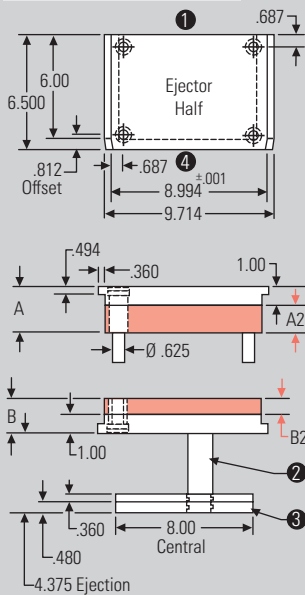

Standard Solid Construction

ITEM NO.	A	B
14/15 SSH 221	1.877	2.377
14/15 SSH 222	2.377	1.877
14/15 SSH 223	2.377	2.377
14/15 SSH 224	2.377	2.877
14/15 SSH 225	2.877	2.377
14/15 SSH 226	2.877	2.877
14/15 SSH 227	2.877	3.377
14/15 SSH 228	3.377	2.877
14/15 SSH 229	3.377	3.377

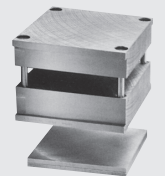

Standard Laminated Construction

ITEM NO.	A	A2	B2	B
14/15 SLH 281	1.877	0.877	1.377	2.377
14/15 SLH 282	2.377	1.377	0.877	1.877
14/15 SLH 283	2.377	1.377	1.377	2.377
14/15 SLH 284	2.377	1.377	1.877	2.877
14/15 SLH 285	2.877	1.877	1.377	2.377
14/15 SLH 286	2.877	1.877	1.877	2.877
14/15 SLH 287	2.877	1.877	2.377	3.377
14/15 SLH 288	3.377	2.377	1.877	2.877
14/15 SLH 289	3.377	2.377	2.377	3.377

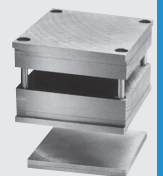

HF Quick-Change H-Style Frame & Companion Insert Molds

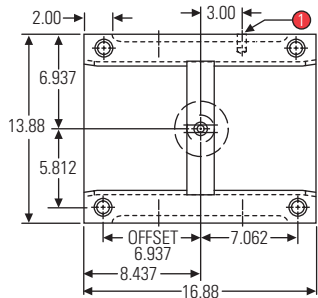
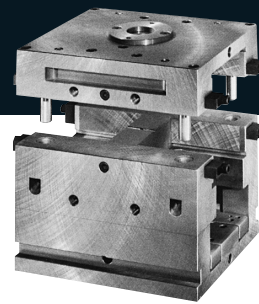

- 1 3/4-10 handling holes supplied standard as shown.
- 2 Ejector system designed for spring loading (quotation on request).
- 3 Waterlines in center sections optional (quotation on request).
- 4 Cutout in ejector plate to accommodate pillar post supplied standard as shown.
- 5 1 1/8 diameter knockouts supplied standard at center and 3.50 off center.
- 6 1/2-13 THD at knockout locations standard as shown.
- 7 Positive ejector plate guidance.
- 8 Locking locating ring supplied standard as shown.

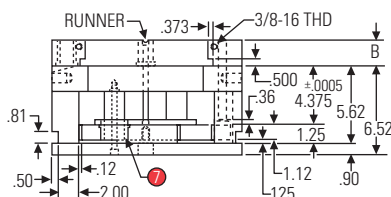
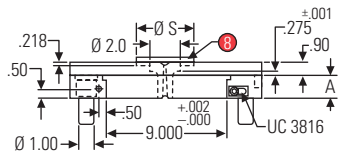
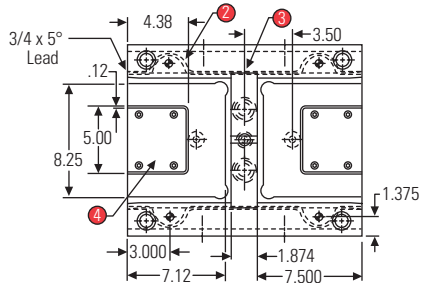

"H" Style Quick-Change Frame

ITEM NO.	A	B
14/17 HF 321	1.877	2.377
14/17 HF 322	2.377	1.877
14/17 HF 323	2.377	2.377
14/17 HF 324	2.377	2.877
14/17 HF 325	2.877	2.377
14/17 HF 326	2.877	2.877
14/17 HF 327	2.877	3.377
14/17 HF 328	3.377	2.877
14/17 HF 329	3.377	3.377

Ordering and installing information for H frame and companion insert molds can be found in the front of this section.

See front of this section for standard and optional frame

Companion Interchangeable Insert Molds

- 1 Frame clamps at this end of insert mold and ejector plates are flush with this end of insert.
- 2 Support post not supplied. Grind +.001 to +.002 higher than height of ejection (see page C 131).
- 3 Thicker plate optional (quotation on request).
- 4 3/4 x 5° lead this end.

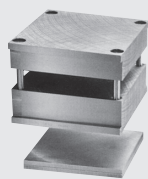

Standard Solid Construction

ITEM NO.	A	B
14/17 SSH 221	1.877	2.377
14/17 SSH 222	2.377	1.877
14/17 SSH 223	2.377	2.377
14/17 SSH 224	2.377	2.877
14/17 SSH 225	2.877	2.377
14/17 SSH 226	2.877	2.877
14/17 SSH 227	2.877	3.377
14/17 SSH 228	3.377	2.877
14/17 SSH 229	3.377	3.377

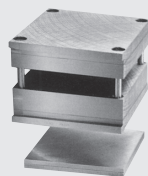

Standard Laminated Construction

ITEM NO.	A	A2	B2	B
14/17 SLH 281	1.877	0.877	1.377	2.377
14/17 SLH 282	2.377	1.377	0.877	1.877
14/17 SLH 283	2.377	1.377	1.377	2.377
14/17 SLH 284	2.377	1.377	1.877	2.877
14/17 SLH 285	2.877	1.877	1.377	2.377
14/17 SLH 286	2.877	1.877	1.877	2.877
14/17 SLH 287	2.877	1.877	2.377	3.377
14/17 SLH 288	3.377	2.377	1.877	2.877
14/17 SLH 289	3.377	2.377	2.377	3.377

Standard Solid: 9.0 x 7.5

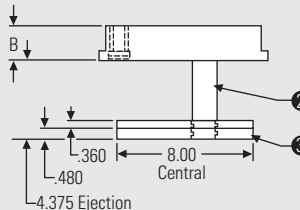
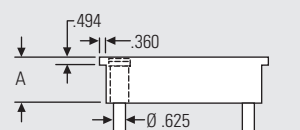
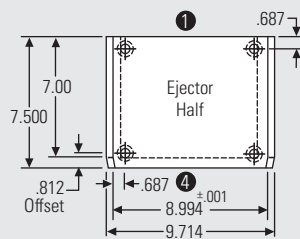

Standard Laminated: 9.0 x 7.5

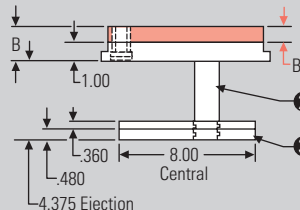
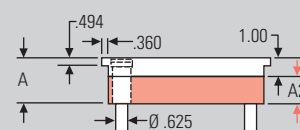
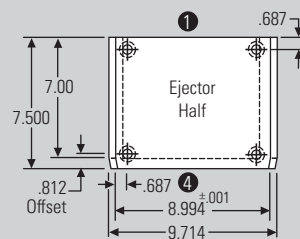

HF Quick-Change H-Style Frame & Companion Insert Molds

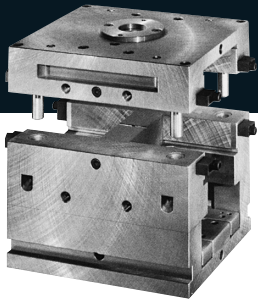

- 1 3/4-10 handling holes supplied standard as shown.
- 2 Ejector system designed for spring loading (quotation on request).
- 3 Waterlines in center sections optional (quotation on request).
- 4 Cutout in ejector plate to accommodate pillar post supplied standard as shown.
- 5 1 1/8 diameter knockouts supplied standard at center and 3.50 off center.
- 6 1/2-13 THD at knockout locations standard as shown.
- 7 Positive ejector plate guidance.
- 8 Locking locating ring supplied standard as shown.

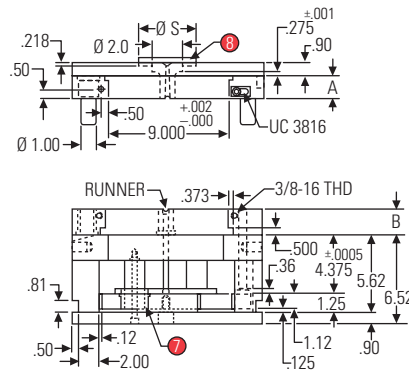
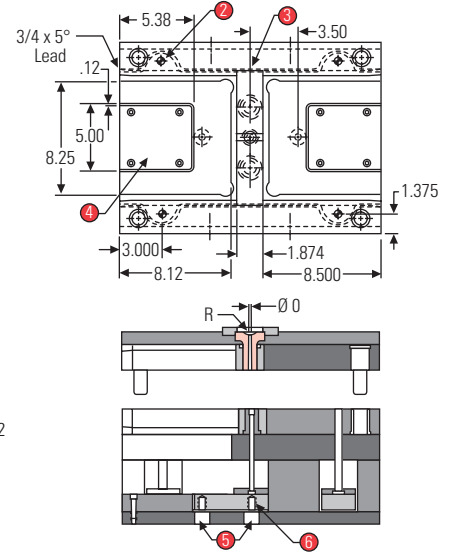
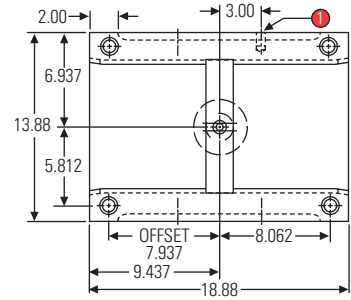

"H" Style Quick-Change Frame

ITEM NO.	A	B
14/19 HF 321	1.877	2.377
14/19 HF 322	2.377	1.877
14/19 HF 323	2.377	2.377
14/19 HF 324	2.377	2.877
14/19 HF 325	2.877	2.377
14/19 HF 326	2.877	2.877
14/19 HF 327	2.877	3.377
14/19 HF 328	3.377	2.877
14/19 HF 329	3.377	3.377

Ordering and installing information for H frame and companion insert molds can be found in the front of this section.

See front of this section for standard and optional frame

Companion Interchangeable Insert Molds

- 1 Frame clamps at this end of insert mold and ejector plates are flush with this end of insert.
- 2 Support post not supplied. Grind +.001 to +.002 higher than height of ejection (see page C 131).
- 3 Thicker plate optional (quotation on request).
- 4 3/4 x 5° lead this end.

Standard Solid:
9.0 x 8.5

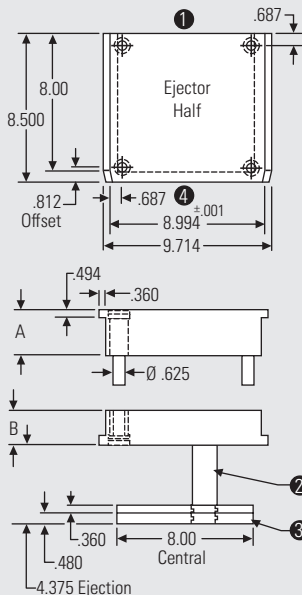

Standard Laminated:
9.0 x 8.5

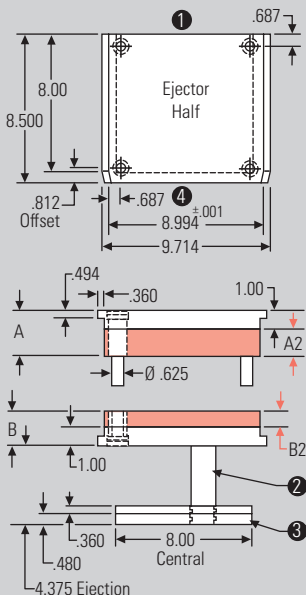

Standard Solid Construction

ITEM NO.	A	B
14/19 SSH 221	1.877	2.377
14/19 SSH 222	2.377	1.877
14/19 SSH 223	2.377	2.377
14/19 SSH 224	2.377	2.877
14/19 SSH 225	2.877	2.377
14/19 SSH 226	2.877	2.877
14/19 SSH 227	2.877	3.377
14/19 SSH 228	3.377	2.877
14/19 SSH 229	3.377	3.377

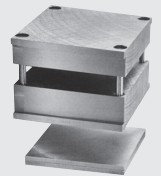

Standard Laminated Construction

ITEM NO.	A	A2	B2	B
14/19 SLH 281	1.877	0.877	1.377	2.377
14/19 SLH 282	2.377	1.377	0.877	1.877
14/19 SLH 283	2.377	1.377	1.377	2.377
14/19 SLH 284	2.377	1.377	1.877	2.877
14/19 SLH 285	2.877	1.877	1.377	2.377
14/19 SLH 286	2.877	1.877	1.877	2.877
14/19 SLH 287	2.877	1.877	2.377	3.377
14/19 SLH 288	3.377	2.377	1.877	2.877
14/19 SLH 289	3.377	2.377	2.377	3.377

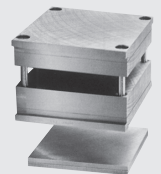

HF Quick-Change H-Style Frame & Companion Insert Molds

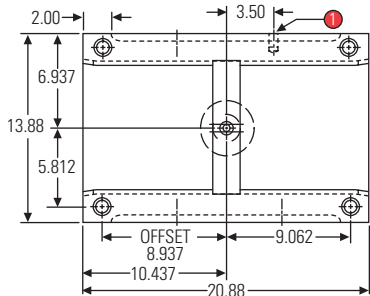
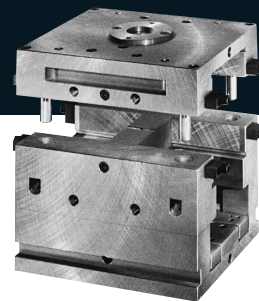

- ① 3/4-10 handling holes supplied standard as shown.
- ② Ejector system designed for spring loading (quotation on request).
- ③ Waterlines in center sections optional (quotation on request).
- ④ Cutout in ejector plate to accommodate pillar post supplied standard as shown.
- ⑤ 1 1/8 diameter knockouts supplied standard at center and 3.50 off center.
- ⑥ 1/2-13 THD at knockout locations standard as shown.
- ⑦ Positive ejector plate guidance.
- ⑧ Locking locating ring supplied standard as shown.

"H" Style Quick-Change Frame

ITEM NO.	A	B
14/21 HF 321	1.877	2.377
14/21 HF 322	2.377	1.877
14/21 HF 323	2.377	2.377
14/21 HF 324	2.377	2.877
14/21 HF 325	2.877	2.377
14/21 HF 326	2.877	2.877
14/21 HF 327	2.877	3.377
14/21 HF 328	3.377	2.877
14/21 HF 329	3.377	3.377

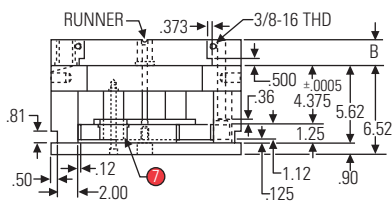
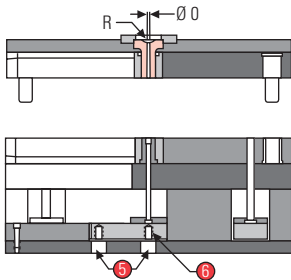
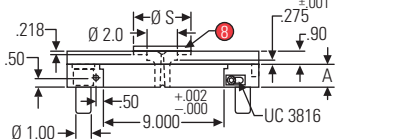
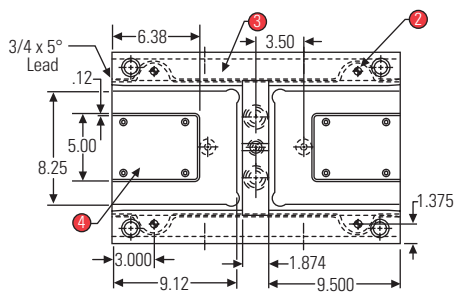

Ordering and installing information for H frame and companion insert molds can be found in the front of this section.

See front of this section for standard and optional frame

Companion Interchangeable Insert Molds

- ① Frame clamps at this end of insert mold and ejector plates are flush with this end of insert.
- ② Support post not supplied. Grind +.001 to +.002 higher than height of ejection (see page C 131).
- ③ Thicker plate optional (quotation on request).
- ④ 3/4 x 5° lead this end.

Standard Solid Construction

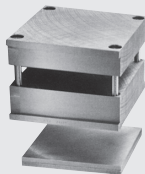

ITEM NO.	A	B
14/21 SSH 221	1.877	2.377
14/21 SSH 222	2.377	1.877
14/21 SSH 223	2.377	2.377
14/21 SSH 224	2.377	2.877
14/21 SSH 225	2.877	2.377
14/21 SSH 226	2.877	2.877
14/21 SSH 227	2.877	3.377
14/21 SSH 228	3.377	2.877
14/21 SSH 229	3.377	3.377

Standard Laminated Construction

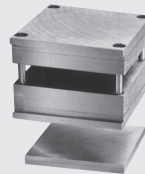

ITEM NO.	A	A2	B2	B
14/21 SLH 281	1.877	0.877	1.377	2.377
14/21 SLH 282	2.377	1.377	0.877	1.877
14/21 SLH 283	2.377	1.377	1.377	2.377
14/21 SLH 284	2.377	1.377	1.877	2.877
14/21 SLH 285	2.877	1.877	1.377	2.377
14/21 SLH 286	2.877	1.877	1.877	2.877
14/21 SLH 287	2.877	1.877	2.377	3.377
14/21 SLH 288	3.377	2.377	1.877	2.877
14/21 SLH 289	3.377	2.377	2.377	3.377

Standard Solid: 9.0 x 9.5

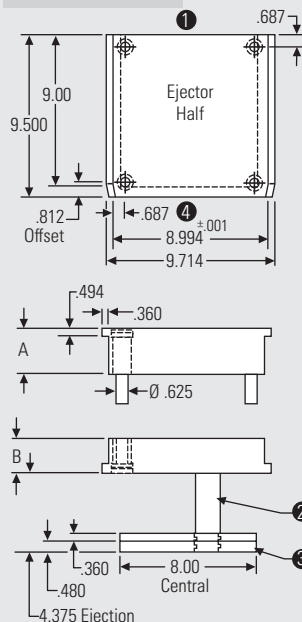

Standard Laminated: 9.0 x 9.5

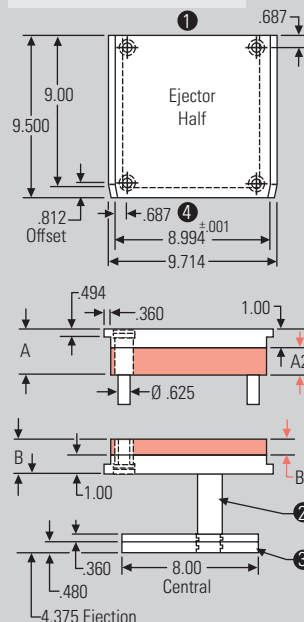

HF Quick-Change H-Style Frame & Companion Insert Molds

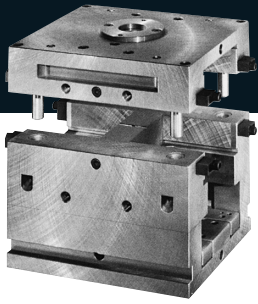

- ① 3/4-10 handling holes supplied standard as shown.
- ② Ejector system designed for spring loading (quotation on request).
- ③ Waterlines in center sections optional (quotation on request).
- ④ Cutout in ejector plate to accommodate pillar post supplied standard as shown.
- ⑤ 1 1/8 diameter knockouts supplied standard at center and 3.50 off center.
- ⑥ 1/2-13 THD at knockout locations standard as shown.
- ⑦ Positive ejector plate guidance.
- ⑧ Locking locating ring supplied standard as shown.

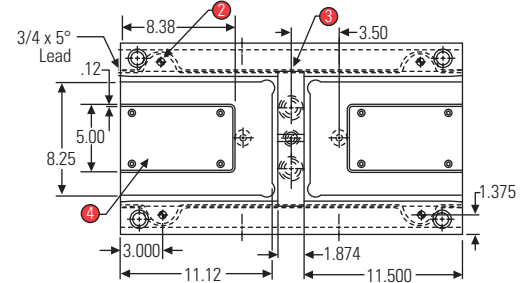
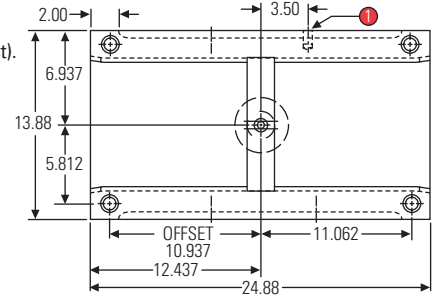

"H" Style Quick-Change Frame

ITEM NO.	A	B
14/25 HF 321	1.877	2.377
14/25 HF 322	2.377	1.877
14/25 HF 323	2.377	2.377
14/25 HF 324	2.377	2.877
14/25 HF 325	2.877	2.377
14/25 HF 326	2.877	2.877
14/25 HF 327	2.877	3.377
14/25 HF 328	3.377	2.877
14/25 HF 329	3.377	3.377

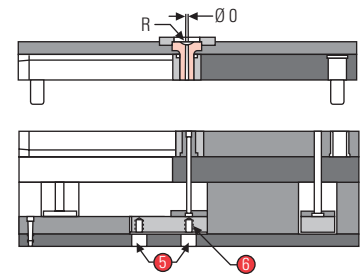
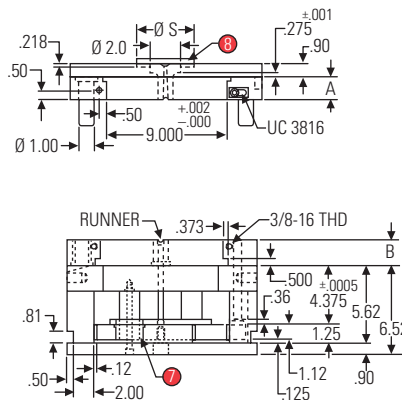

Ordering and installing information for H frame and companion insert molds can be found in the front of this section.

See front of this section for standard and optional frame

Companion Interchangeable Insert Molds

- ① Frame clamps at this end of insert mold and ejector plates are flush with this end of insert.
- ② Support post not supplied. Grind +.001 to +.002 higher than height of ejection (see page C 131).
- ③ Thicker plate optional (quotation on request).
- ④ 3/4 x 5° lead this end.

Standard Solid: 9.0 x 11.5

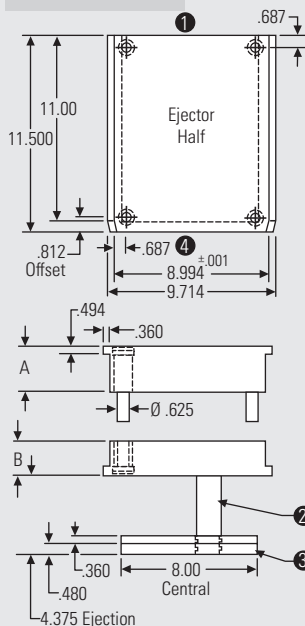

Standard Laminated: 9.0 x 11.5

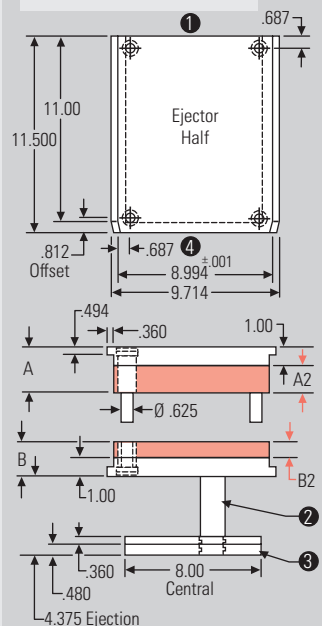

Standard Solid Construction

ITEM NO.	A	B
14/25 SSH 221	1.877	2.377
14/25 SSH 222	2.377	1.877
14/25 SSH 223	2.377	2.377
14/25 SSH 224	2.377	2.877
14/25 SSH 225	2.877	2.377
14/25 SSH 226	2.877	2.877
14/25 SSH 227	2.877	3.377
14/25 SSH 228	3.377	2.877
14/25 SSH 229	3.377	3.377

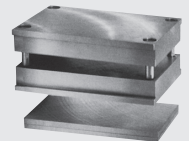

Standard Laminated Construction

ITEM NO.	A	A2	B2	B
14/25 SLH 281	1.877	0.877	1.377	2.377
14/25 SLH 282	2.377	1.377	0.877	1.877
14/25 SLH 283	2.377	1.377	1.377	2.377
14/25 SLH 284	2.377	1.377	1.877	2.877
14/25 SLH 285	2.877	1.877	1.377	2.377
14/25 SLH 286	2.877	1.877	1.877	2.877
14/25 SLH 287	2.877	1.877	2.377	3.377
14/25 SLH 288	3.377	2.377	1.877	2.877
14/25 SLH 289	3.377	2.377	2.377	3.377

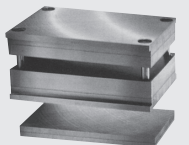

HF Quick-Change H-Style Frame & Companion Insert Molds

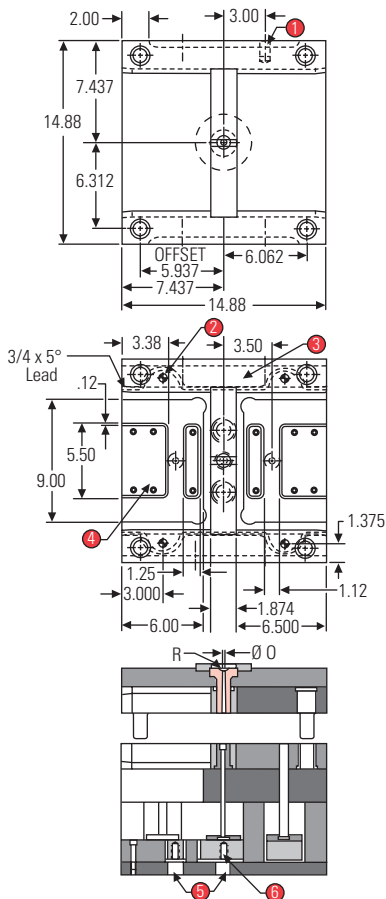
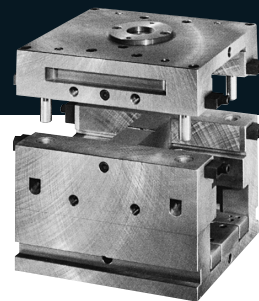

- 1 3/4-10 handling holes supplied standard as shown.
- 2 Ejector system designed for spring loading (quotation on request).
- 3 Waterlines in center sections optional (quotation on request).
- 4 Cutout in ejector plate to accommodate pillar post supplied standard as shown.
- 5 1 1/8 diameter knockouts supplied standard at center and 3.50 off center.
- 6 1/2-13 THD at knockout locations standard as shown.
- 7 Positive ejector plate guidance.
- 8 Locking locating ring supplied standard as shown.

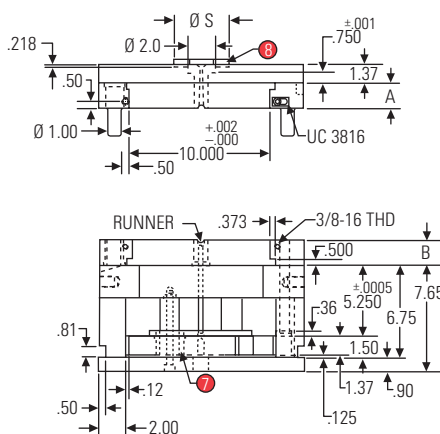

"H" Style Quick-Change Frame

ITEM NO.	A	B
15/15 HF 321	1.877	2.377
15/15 HF 322	2.377	1.877
15/15 HF 323	2.377	2.377
15/15 HF 324	2.377	2.877
15/15 HF 325	2.877	2.377
15/15 HF 326	2.877	2.877
15/15 HF 327	2.877	3.377
15/15 HF 328	2.877	3.877
15/15 HF 329	3.877	3.377
15/15 HF 330	3.877	3.877

Ordering and installing information for H frame and companion insert molds can be found in the front of this section.

See front of this section for standard and optional frame

Companion Interchangeable Insert Molds

- 1 Frame clamps at this end of insert mold and ejector plates are flush with this end of insert.
- 2 Support post not supplied. Grind +.001 to +.002 higher than height of ejection (see page C 131).
- 3 Thicker plate optional (quotation on request).
- 4 3/4 x 5° lead this end.

Standard Solid Construction

ITEM NO.	A	B
15/15 SSH 221	1.877	2.377
15/15 SSH 222	2.377	1.877
15/15 SSH 223	2.377	2.377
15/15 SSH 224	2.377	2.877
15/15 SSH 225	2.877	2.377
15/15 SSH 226	2.877	2.877
15/15 SSH 227	2.877	3.377
15/15 SSH 228	2.877	3.877
15/15 SSH 229	3.877	3.377
15/15 SSH 230	3.877	3.877

Standard Laminated Construction

ITEM NO.	A	A2	B2	B
15/15 SLH 281	1.877	0.877	1.377	2.377
15/15 SLH 282	2.377	1.377	0.877	1.877
15/15 SLH 283	2.377	1.377	1.377	2.377
15/15 SLH 284	2.377	1.377	1.877	2.877
15/15 SLH 285	2.877	1.877	1.377	2.377
15/15 SLH 286	2.877	1.877	1.877	2.877
15/15 SLH 287	2.877	1.877	2.377	3.377
15/15 SLH 288	2.877	1.877	2.877	3.877
15/15 SLH 289	3.877	2.877	2.377	3.377
15/15 SLH 290	3.877	2.877	2.877	3.877

Standard Solid: 10.0 x 6.5

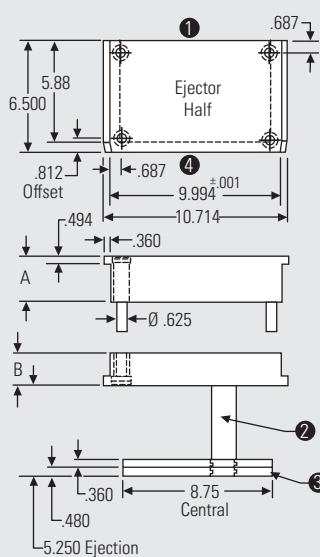

Standard Laminated: 10.0 x 6.5

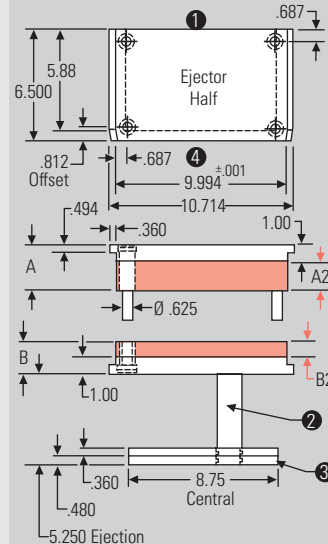

HF Quick-Change H-Style Frame & Companion Insert Molds

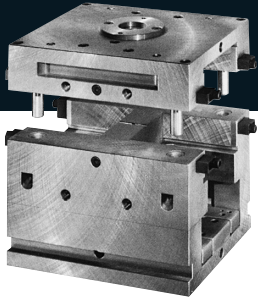

- 1 3/4-10 handling holes supplied standard as shown.
- 2 Ejector system designed for spring loading (quotation on request).
- 3 Waterlines in center sections optional (quotation on request).
- 4 Cutout in ejector plate to accommodate pillar post supplied standard as shown.
- 5 1 1/8 diameter knockouts supplied standard at center and 3.50 off center.
- 6 1/2-13 THD at knockout locations standard as shown.
- 7 Positive ejector plate guidance.
- 8 Locking locating ring supplied standard as shown.

"H" Style Quick-Change Frame

ITEM NO.	A	B
15/17 HF 321	1.877	2.377
15/17 HF 322	2.377	1.877
15/17 HF 323	2.377	2.377
15/17 HF 324	2.377	2.877
15/17 HF 325	2.877	2.377
15/17 HF 326	2.877	2.877
15/17 HF 327	2.877	3.377
15/17 HF 328	2.877	3.877
15/17 HF 329	3.877	3.377
15/17 HF 330	3.877	3.877

Ordering and installing information for H frame and companion insert molds can be found in the front of this section.

See front of this section for standard and optional frame

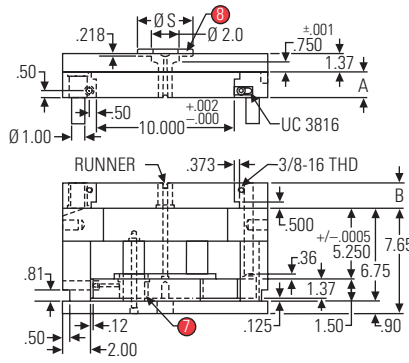
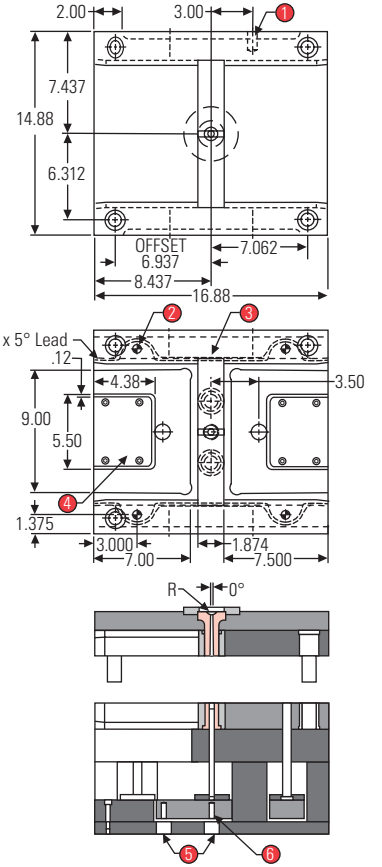

Companion Interchangeable Insert Molds

- 1 Frame clamps at this end of insert mold and ejector plates are flush with this end of insert.
- 2 Support post not supplied. Grind +.001 to +.002 higher than height of ejection (see page C 131).
- 3 Thicker plate optional (quotation on request).
- 4 3/4 x 5° lead this end.

Standard Solid:
10.0 x 7.5

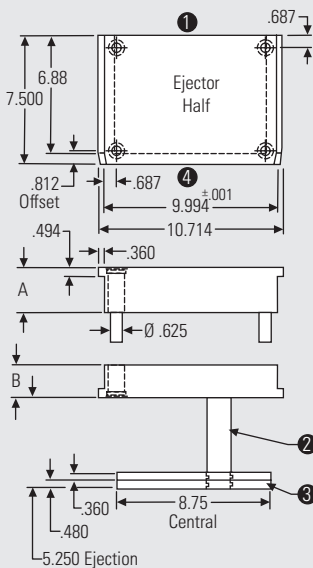

Standard Laminated:
10.0 x 7.5

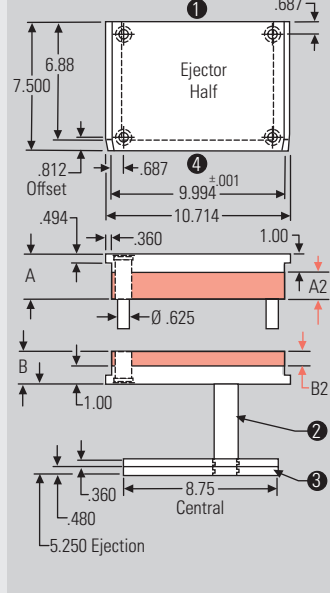

Standard Solid Construction

ITEM NO.	A	B
15/17 SSH 221	1.877	2.377
15/17 SSH 222	2.377	1.877
15/17 SSH 223	2.377	2.377
15/17 SSH 224	2.377	2.877
15/17 SSH 225	2.877	2.377
15/17 SSH 226	2.877	2.877
15/17 SSH 227	2.877	3.377
15/17 SSH 228	2.877	3.877
15/17 SSH 229	3.877	3.377
15/17 SSH 230	3.877	3.877

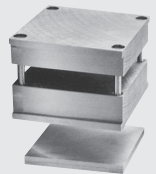

Standard Laminated Construction

ITEM NO.	A	A2	B2	B
15/17 SLH 281	1.877	0.877	1.377	2.377
15/17 SLH 282	2.377	1.377	0.877	1.877
15/17 SLH 283	2.377	1.377	1.377	2.377
15/17 SLH 284	2.377	1.377	1.877	2.877
15/17 SLH 285	2.877	1.877	1.377	2.377
15/17 SLH 286	2.877	1.877	1.877	2.877
15/17 SLH 287	2.877	1.877	2.377	3.377
15/17 SLH 288	2.877	1.877	2.877	3.877
15/17 SLH 289	3.877	2.877	2.377	3.377
15/17 SLH 290	3.877	2.877	2.877	3.877

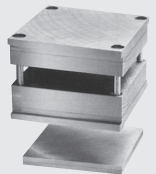

HF Quick-Change H-Style Frame & Companion Insert Molds

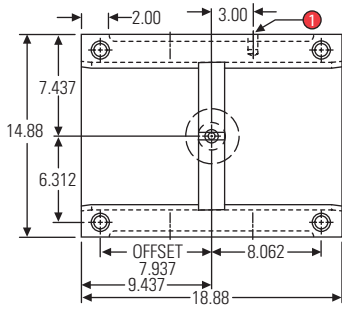
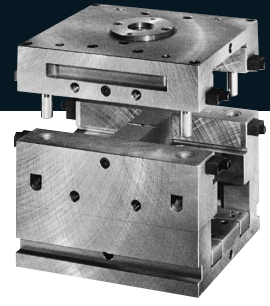

- 1 3/4-10 handling holes supplied standard as shown.
- 2 Ejector system designed for spring loading (quotation on request).
- 3 Waterlines in center sections optional (quotation on request).
- 4 Cutout in ejector plate to accommodate pillar post supplied standard as shown.
- 5 1 1/8 diameter knockouts supplied standard at center and 3.50 off center.
- 6 1/2-13 THD at knockout locations standard as shown.
- 7 Positive ejector plate guidance.
- 8 Locking locating ring supplied standard as shown.

"H" Style Quick-Change Frame

ITEM NO.	A	B
15/19 HF 321	1.877	2.377
15/19 HF 322	2.377	1.877
15/19 HF 323	2.377	2.377
15/19 HF 324	2.377	2.877
15/19 HF 325	2.877	2.377
15/19 HF 326	2.877	2.877
15/19 HF 327	2.877	3.377
15/19 HF 328	2.877	3.877
15/19 HF 329	3.877	3.377
15/19 HF 330	3.877	3.877

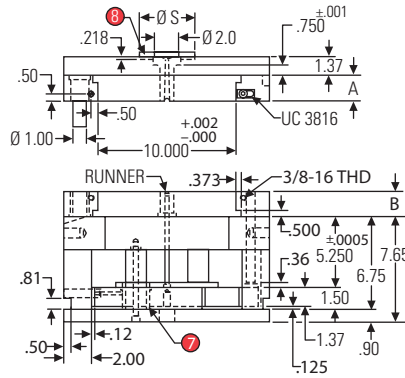
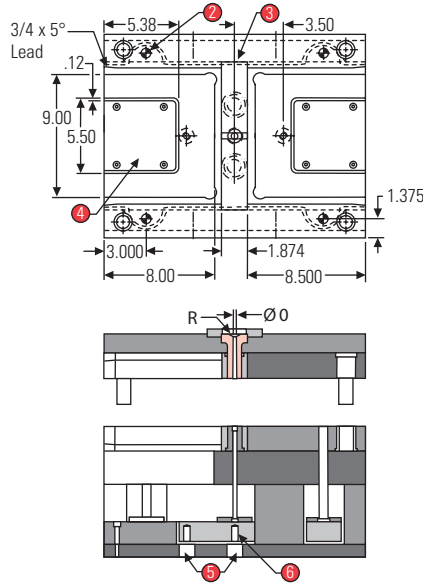

Ordering and installing information for H frame and companion insert molds can be found in the front of this section.

See front of this section for standard and optional frame

Companion Interchangeable Insert Molds

- 1 Frame clamps at this end of insert mold and ejector plates are flush with this end of insert.
- 2 Support post not supplied. Grind +.001 to +.002 higher than height of ejection (see page C 131).
- 3 Thicker plate optional (quotation on request).
- 4 3/4 x 5° lead this end.

Standard Solid Construction

ITEM NO.	A	B
15/19 SSH 221	1.877	2.377
15/19 SSH 222	2.377	1.877
15/19 SSH 223	2.377	2.377
15/19 SSH 224	2.377	2.877
15/19 SSH 225	2.877	2.377
15/19 SSH 226	2.877	2.877
15/19 SSH 227	2.877	3.377
15/19 SSH 228	2.877	3.877
15/19 SSH 229	3.877	3.377
15/19 SSH 230	3.877	3.877

Standard Laminated Construction

ITEM NO.	A	A2	B2	B
15/19 SLH 281	1.877	0.877	1.377	2.377
15/19 SLH 282	2.377	1.377	0.877	1.877
15/19 SLH 283	2.377	1.377	1.377	2.377
15/19 SLH 284	2.377	1.377	1.877	2.877
15/19 SLH 285	2.877	1.877	1.377	2.377
15/19 SLH 286	2.877	1.877	1.877	2.877
15/19 SLH 287	2.877	1.877	2.377	3.377
15/19 SLH 288	2.877	1.877	2.877	3.877
15/19 SLH 289	3.877	2.877	2.377	3.377
15/19 SLH 290	3.877	2.877	2.877	3.877

Standard Solid: 10.0 x 8.5

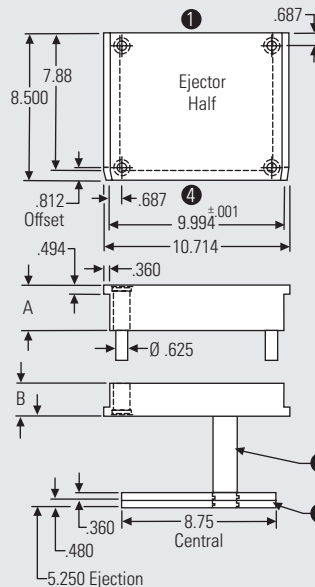

Standard Laminated: 10.0 x 8.5

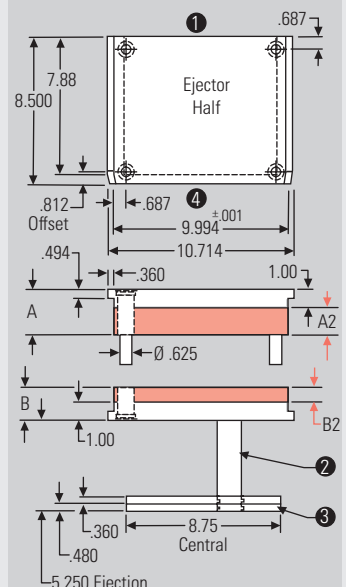

HF Quick-Change H-Style Frame & Companion Insert Molds

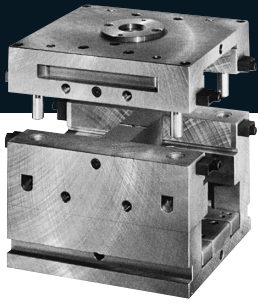

- ① 3/4-10 handling holes supplied standard as shown.
- ② Ejector system designed for spring loading (quotation on request).
- ③ Waterlines in center sections optional (quotation on request).
- ④ Cutout in ejector plate to accommodate pillar post supplied standard as shown.
- ⑤ 1 1/8 diameter knockouts supplied standard at center and 3.50 off center.
- ⑥ 1/2-13 THD at knockout locations standard as shown.
- ⑦ Positive ejector plate guidance.
- ⑧ Locking locating ring supplied standard as shown.

"H" Style Quick-Change Frame

ITEM NO.	A	B
15/21 HF 321	1.877	2.377
15/21 HF 322	2.377	1.877
15/21 HF 323	2.377	2.377
15/21 HF 324	2.377	2.877
15/21 HF 325	2.877	2.377
15/21 HF 326	2.877	2.877
15/21 HF 327	2.877	3.377
15/21 HF 328	2.877	3.877
15/21 HF 329	3.877	3.377
15/21 HF 330	3.877	3.877

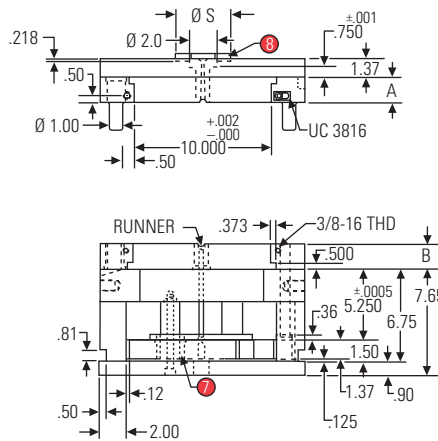
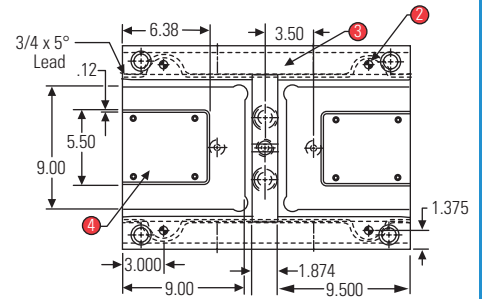
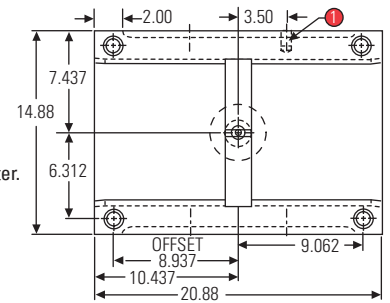

Ordering and installing information for H frame and companion insert molds can be found in the front of this section.

See front of this section for standard and optional frame

Companion Interchangeable Insert Molds

- ① Frame clamps at this end of insert mold and ejector plates are flush with this end of insert.
- ② Support post not supplied. Grind +.001 to +.002 higher than height of ejection (see page C 131).
- ③ Thicker plate optional (quotation on request).
- ④ 3/4 x 5° lead this end.

Standard Solid:
10.0 x 9.5

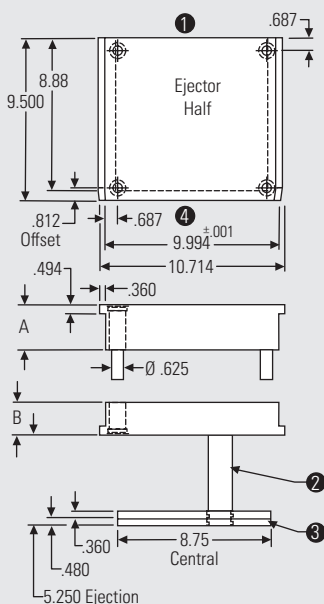

Standard Laminated:
10.0 x 9.5

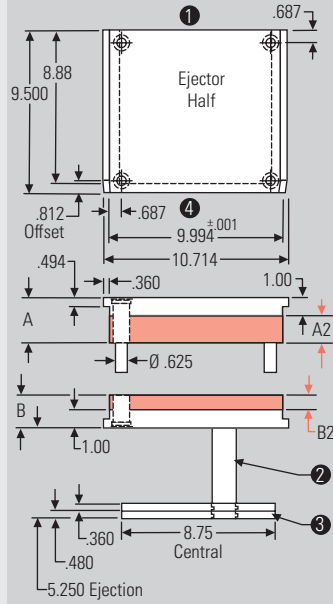

Standard Solid Construction

ITEM NO.	A	B
15/21 SSH 221	1.877	2.377
15/21 SSH 222	2.377	1.877
15/21 SSH 223	2.377	2.377
15/21 SSH 224	2.377	2.877
15/21 SSH 225	2.877	2.377
15/21 SSH 226	2.877	2.877
15/21 SSH 227	2.877	3.377
15/21 SSH 228	2.877	3.877
15/21 SSH 229	3.877	3.377
15/21 SSH 230	3.877	3.877

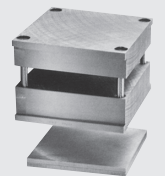

Standard Laminated Construction

ITEM NO.	A	A2	B2	B
15/21 SLH 281	1.877	0.877	1.377	2.377
15/21 SLH 282	2.377	1.377	0.877	1.877
15/21 SLH 283	2.377	1.377	1.377	2.377
15/21 SLH 284	2.377	1.377	1.877	2.877
15/21 SLH 285	2.877	1.877	1.377	2.377
15/21 SLH 286	2.877	1.877	1.877	2.877
15/21 SLH 287	2.877	1.877	2.377	3.377
15/21 SLH 288	2.877	1.877	2.877	3.877
15/21 SLH 289	3.877	2.877	2.377	3.377
15/21 SLH 290	3.877	2.877	2.877	3.877

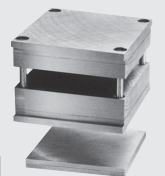

HF Quick-Change H-Style Frame & Companion Insert Molds

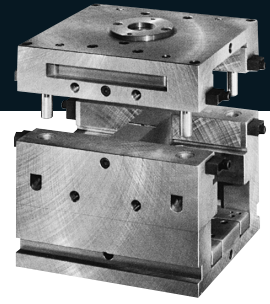

"H" Style Quick-Change Frame

ITEM NO.	A	B
15/25 HF 321	1.877	2.377
15/25 HF 322	2.377	1.877
15/25 HF 323	2.377	2.377
15/25 HF 324	2.377	2.877
15/25 HF 325	2.877	2.377
15/25 HF 326	2.877	2.877
15/25 HF 327	2.877	3.377
15/25 HF 328	2.877	3.877
15/25 HF 329	3.877	3.377
15/25 HF 330	3.877	3.877

Ordering and installing information for H frame and companion insert molds can be found in the front of this section.

See front of this section for standard and optional frame

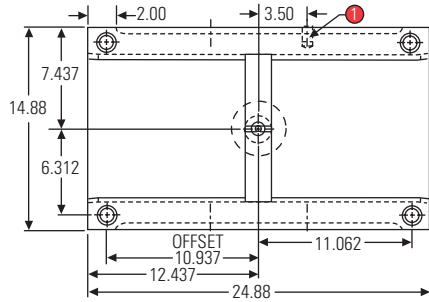

- 1 3/4-10 handling holes supplied standard as shown.
- 2 Ejector system designed for spring loading (quotation on request).
- 3 Waterlines in center sections optional (quotation on request).
- 4 Cutout in ejector plate to accommodate pillar post supplied standard as shown.
- 5 1 1/8 diameter knockouts supplied standard at center and 3.50 off center.
- 6 1/2-13 THD at knockout locations standard as shown.
- 7 Positive ejector plate guidance.
- 8 Locking locating ring supplied standard as shown.

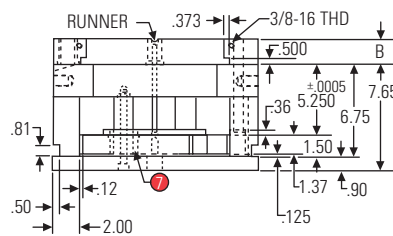
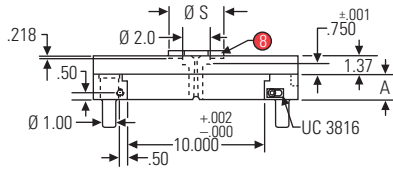
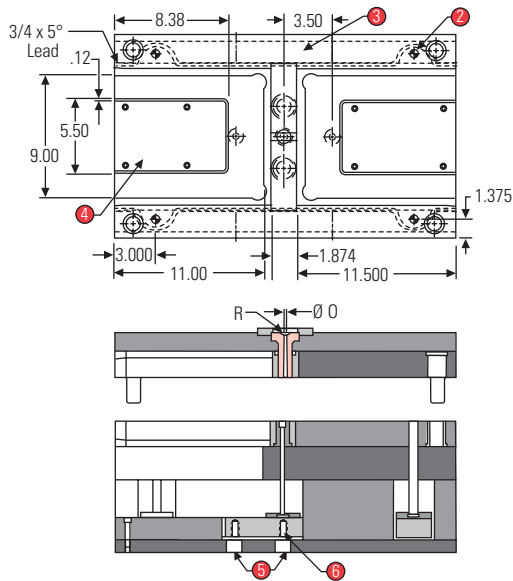

Standard Solid Construction

ITEM NO.	A	B
15/25 SSH 221	1.877	2.377
15/25 SSH 222	2.377	1.877
15/25 SSH 223	2.377	2.377
15/25 SSH 224	2.377	2.877
15/25 SSH 225	2.877	2.377
15/25 SSH 226	2.877	2.877
15/25 SSH 227	2.877	3.377
15/25 SSH 228	2.877	3.877
15/25 SSH 229	3.877	3.377
15/25 SSH 230	3.877	3.877

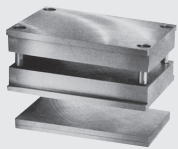

Standard Laminated Construction

ITEM NO.	A	A2	B2	B
15/25 SLH 281	1.877	0.877	1.377	2.377
15/25 SLH 282	2.377	1.377	0.877	1.877
15/25 SLH 283	2.377	1.377	1.377	2.377
15/25 SLH 284	2.377	1.377	1.877	2.877
15/25 SLH 285	2.877	1.877	1.377	2.377
15/25 SLH 286	2.877	1.877	1.877	2.877
15/25 SLH 287	2.877	1.877	2.377	3.377
15/25 SLH 288	2.877	1.877	2.877	3.877
15/25 SLH 289	3.877	2.877	2.377	3.377
15/25 SLH 290	3.877	2.877	2.877	3.877

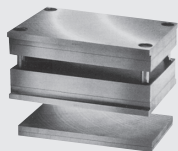

Companion Interchangeable Insert Molds

- 1 Frame clamps at this end of insert mold and ejector plates are flush with this end of insert.
- 2 Support post not supplied. Grind +.001 to +.002 higher than height of ejection (see page C 131).
- 3 Thicker plate optional (quotation on request).
- 4 3/4 x 5° lead this end.

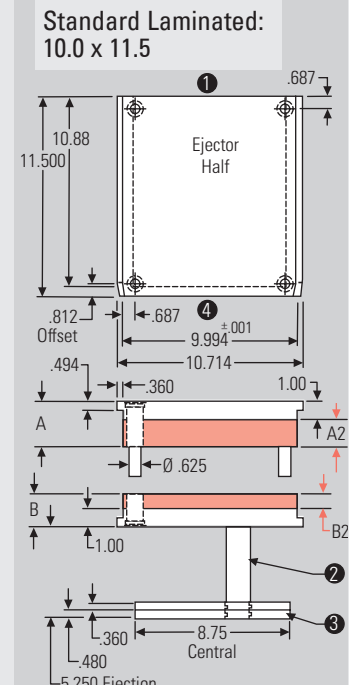
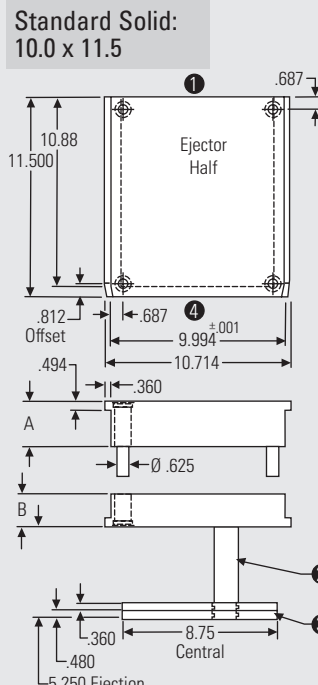

HF Quick-Change H-Style Frame & Companion Insert Molds

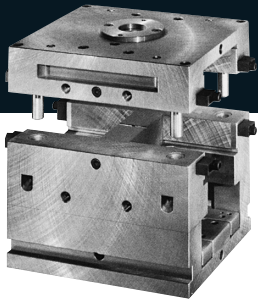

"H" Style Quick-Change Frame

ITEM NO.	A	B
17/19 HF 321	1.877	2.377
17/19 HF 322	2.377	1.877
17/19 HF 323	2.377	2.377
17/19 HF 324	2.377	2.877
17/19 HF 325	2.877	2.377
17/19 HF 326	2.877	2.877
17/19 HF 327	2.877	3.377
17/19 HF 328	2.877	3.877
17/19 HF 329	3.877	3.377
17/19 HF 330	3.877	3.877

- ① 3/4-10 handling holes supplied standard as shown.
- ② Ejector system designed for spring loading (quotation on request).
- ③ Waterlines in center sections optional (quotation on request).
- ④ Cutout in ejector plate to accommodate pillar post supplied standard as shown.
- ⑤ 1 1/8 diameter knockouts supplied standard at center and 3.50 off center.
- ⑥ 1/2-13 THD at knockout locations standard as shown.
- ⑦ Positive ejector plate guidance.
- ⑧ Locking locating ring supplied standard as shown.

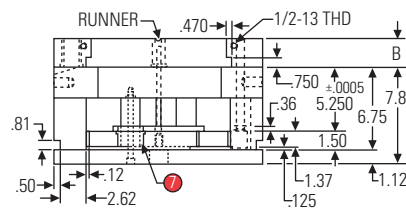
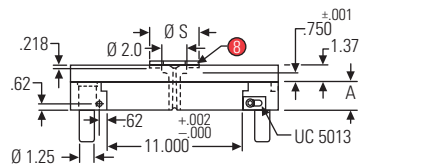
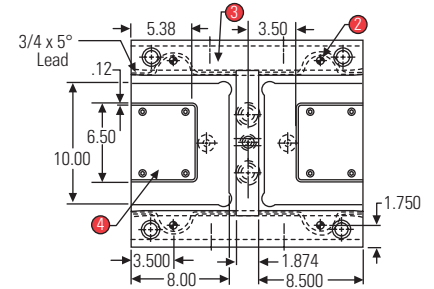
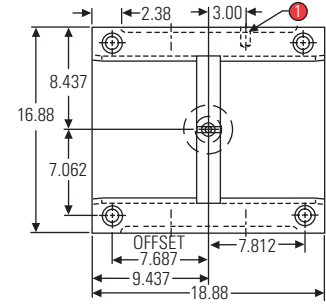

Ordering and installing information for H frame and companion insert molds can be found in the front of this section.

See front of this section for standard and optional frame

Companion Interchangeable Insert Molds

- ① Frame clamps at this end of insert mold and ejector plates are flush with this end of insert.
- ② Support post not supplied. Grind +.001 to +.002 higher than height of ejection (see page C 131).
- ③ Thicker plate optional (quotation on request).
- ④ 3/4 x 5° lead this end.

Standard Solid:
11.0 x 8.5

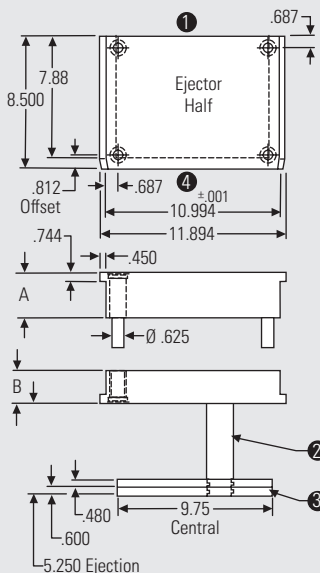

Standard Laminated:
11.0 x 8.5

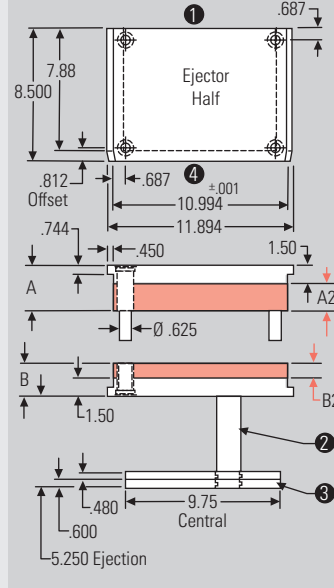

Standard Solid Construction

ITEM NO.	A	B
17/19 SSH 221	1.877	2.377
17/19 SSH 222	2.377	1.877
17/19 SSH 223	2.377	2.377
17/19 SSH 224	2.377	2.877
17/19 SSH 225	2.877	2.377
17/19 SSH 226	2.877	2.877
17/19 SSH 227	2.877	3.377
17/19 SSH 228	2.877	3.877
17/19 SSH 229	3.877	3.377
17/19 SSH 230	3.877	3.877

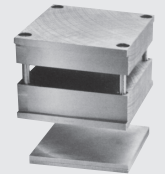

Standard Laminated Construction

ITEM NO.	A	A2	B2	B
17/19 SLH 283	2.377	0.877	0.877	2.377
17/19 SLH 284	2.377	0.877	1.377	2.877
17/19 SLH 285	2.877	1.377	0.877	2.377
17/19 SLH 286	2.877	1.377	1.377	2.877
17/19 SLH 287	2.877	1.377	1.877	3.377
17/19 SLH 288	2.877	1.377	2.377	3.877
17/19 SLH 289	3.877	2.377	1.877	3.377
17/19 SLH 290	3.877	2.377	2.377	3.877

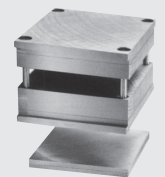

HF Quick-Change H-Style Frame & Companion Insert Molds

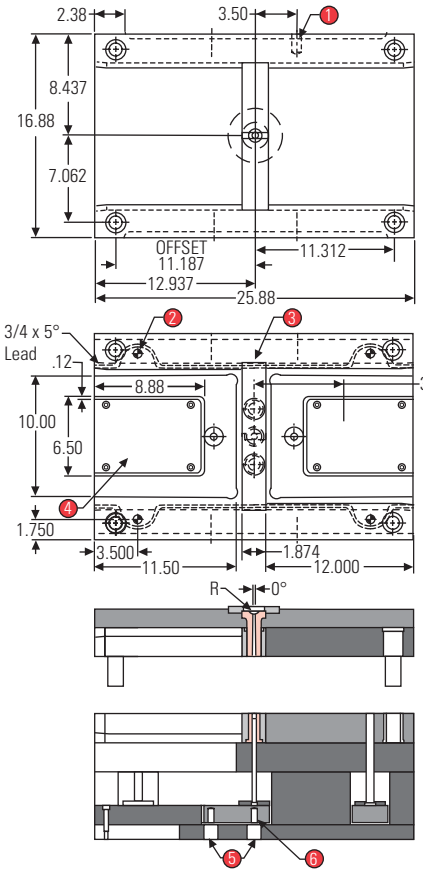
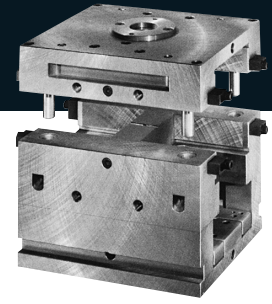

- 1 3/4-10 handling holes supplied standard as shown.
- 2 Ejector system designed for spring loading (quotation on request).
- 3 Waterlines in center sections optional (quotation on request).
- 4 Cutout in ejector plate to accommodate pillar post supplied standard as shown.
- 5 1 1/8 diameter knockouts supplied standard at center and 3.50 off center.
- 6 1/2-13 THD at knockout locations standard as shown.
- 7 Positive ejector plate guidance.
- 8 Locking locating ring supplied standard as shown.

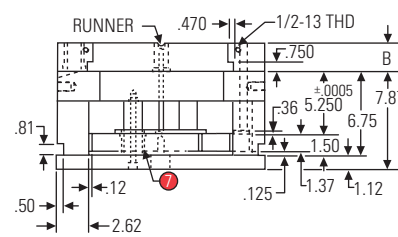
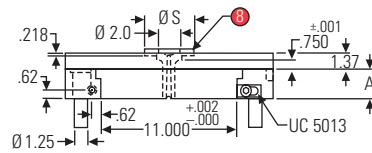

"H" Style Quick-Change Frame

ITEM NO.	A	B
17/26 HF 321	1.877	2.377
17/26 HF 322	2.377	1.877
17/26 HF 323	2.377	2.377
17/26 HF 324	2.377	2.877
17/26 HF 325	2.877	2.377
17/26 HF 326	2.877	2.877
17/26 HF 327	2.877	3.377
17/26 HF 328	2.877	3.877
17/26 HF 329	3.877	3.377
17/26 HF 330	3.877	3.877

Ordering and installing information for H frame and companion insert molds can be found in the front of this section.

See front of this section for standard and optional frame

Companion Interchangeable Insert Molds

- 1 Frame clamps at this end of insert mold and ejector plates are flush with this end of insert.
- 2 Support post not supplied. Grind +.001 to +.002 higher than height of ejection (see page C 131).
- 3 Thicker plate optional (quotation on request).
- 4 3/4 x 5° lead this end.

Standard Solid Construction

ITEM NO.	A	B
17/26 SSH 221	1.877	2.377
17/26 SSH 222	2.377	1.877
17/26 SSH 223	2.377	2.377
17/26 SSH 224	2.377	2.877
17/26 SSH 225	2.877	2.377
17/26 SSH 226	2.877	2.877
17/26 SSH 227	2.877	3.377
17/26 SSH 228	2.877	3.877
17/26 SSH 229	3.877	3.377
17/26 SSH 230	3.877	3.877

Standard Laminated Construction

ITEM NO.	A	A2	B2	B
17/26 SLH 283	2.377	0.877	0.877	2.377
17/26 SLH 284	2.377	0.877	1.377	2.877
17/26 SLH 285	2.877	1.377	0.877	2.377
17/26 SLH 286	2.877	1.377	1.377	2.877
17/26 SLH 287	2.877	1.377	1.877	3.377
17/26 SLH 288	2.877	1.377	2.377	3.877
17/26 SLH 289	3.877	2.377	1.877	3.377
17/26 SLH 290	3.877	2.377	2.377	3.877

Standard Solid: 11.0 x 12.0

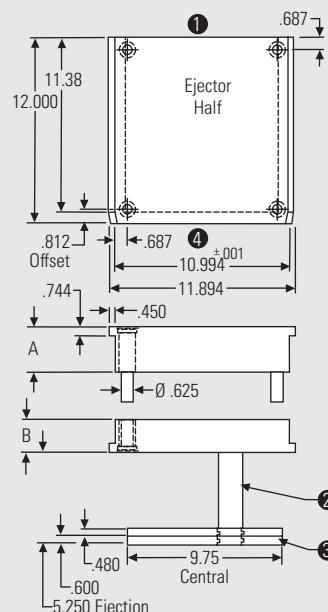

Standard Laminated: 11.0 x 12.0

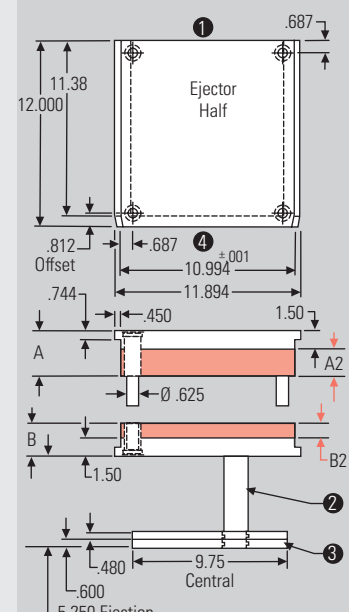

HF Quick-Change H-Style Frame & Companion Insert Molds

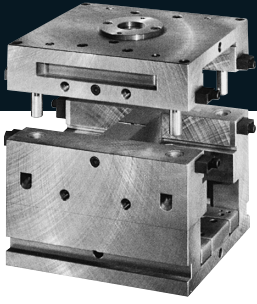

- 1 3/4-10 handling holes supplied standard as shown.
- 2 Ejector system designed for spring loading (quotation on request).
- 3 Waterlines in center sections optional (quotation on request).
- 4 Cutout in ejector plate to accommodate pillar post supplied standard as shown.
- 5 1 1/8 diameter knockouts supplied standard at center and 3.50 off center.
- 6 1/2-13 THD at knockout locations standard as shown.
- 7 Positive ejector plate guidance.
- 8 Locking locating ring supplied standard as shown.

"H" Style Quick-Change Frame

ITEM NO.	A	B
18/22 HF 321	1.877	2.377
18/22 HF 322	2.377	1.877
18/22 HF 323	2.377	2.377
18/22 HF 324	2.377	2.877
18/22 HF 325	2.877	2.377
18/22 HF 326	2.877	2.877
18/22 HF 327	2.877	3.377
18/22 HF 328	2.877	3.877
18/22 HF 329	3.877	3.377
18/22 HF 330	3.877	3.877

Ordering and installing information for H frame and companion insert molds can be found in the front of this section.

See front of this section for standard and optional frame

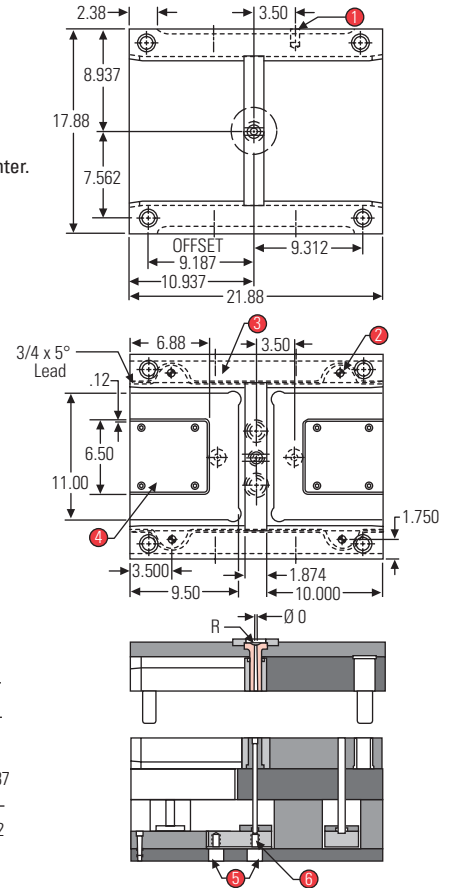
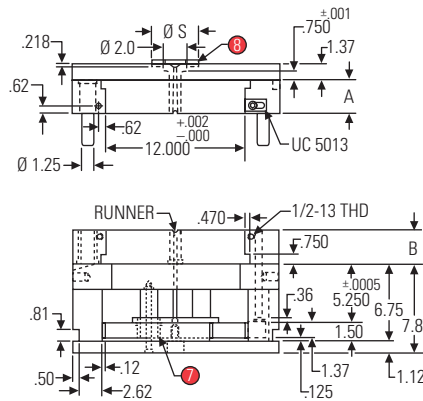

Companion Interchangeable Insert Molds

- 1 Frame clamps at this end of insert mold and ejector plates are flush with this end of insert.
- 2 Support post not supplied. Grind $+0.001$ to $+0.002$ higher than height of ejection (see page C 131).
- 3 Thicker plate optional (quotation on request).
- 4 3/4 x 5° lead this end.

Standard Solid:
12.0 x 10.0

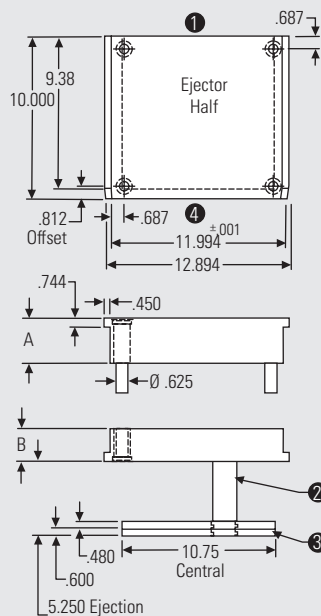

Standard Laminated:
12.0 x 10.0

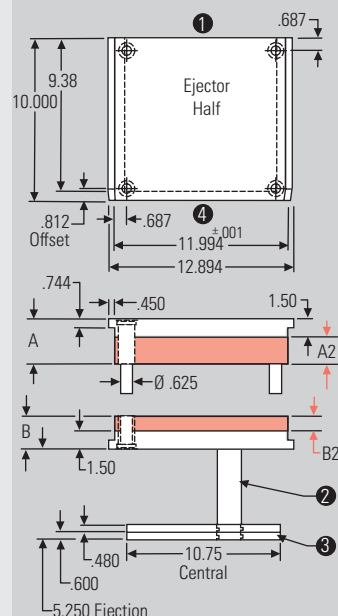

Standard Solid Construction

ITEM NO.	A	B
18/22 SSH 221	1.877	2.377
18/22 SSH 222	2.377	1.877
18/22 SSH 223	2.377	2.377
18/22 SSH 224	2.377	2.877
18/22 SSH 225	2.877	2.377
18/22 SSH 226	2.877	2.877
18/22 SSH 227	2.877	3.377
18/22 SSH 228	2.877	3.877
18/22 SSH 229	3.877	3.377
18/22 SSH 230	3.877	3.877

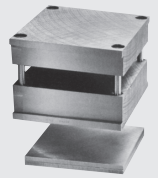

Standard Laminated Construction

ITEM NO.	A	A2	B2	B
18/22 SLH 283	2.377	0.877	0.877	2.377
18/22 SLH 284	2.377	0.877	1.377	2.877
18/22 SLH 285	2.877	1.377	0.877	2.377
18/22 SLH 286	2.877	1.377	1.377	2.877
18/22 SLH 287	2.877	1.377	1.877	3.377
18/22 SLH 288	2.877	1.377	2.377	3.877
18/22 SLH 289	3.877	2.377	1.877	3.377
18/22 SLH 290	3.877	2.377	2.377	3.877

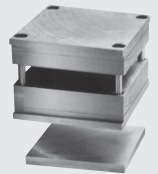

HF Quick-Change H-Style Frame & Companion Insert Molds

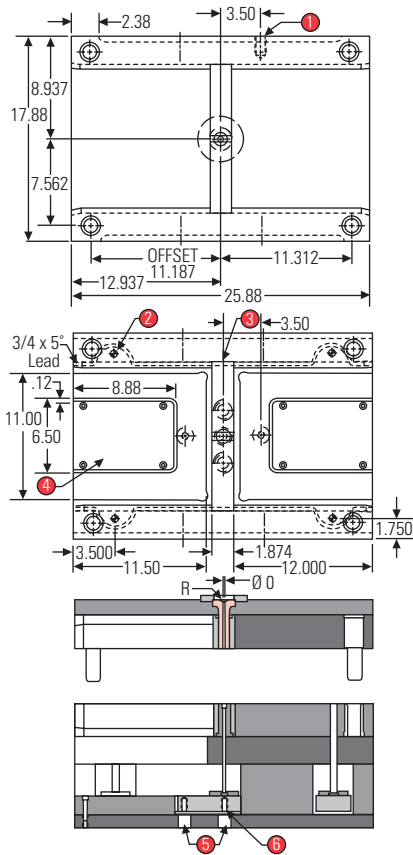
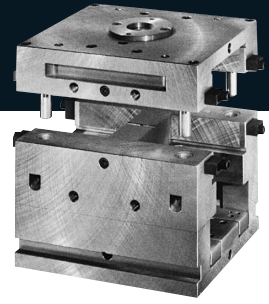

- 1 3/4-10 handling holes supplied standard as shown.
- 2 Ejector system designed for spring loading (quotation on request).
- 3 Waterlines in center sections optional (quotation on request).
- 4 Cutout in ejector plate to accommodate pillar post supplied standard as shown.
- 5 1 1/8 diameter knockouts supplied standard at center and 3.50 off center.
- 6 1/2-13 THD at knockout locations standard as shown.
- 7 Positive ejector plate guidance.
- 8 Locking locating ring supplied standard as shown.

"H" Style Quick-Change Frame

ITEM NO.	A	B
18/26 HF 321	1.877	2.377
18/26 HF 322	2.377	1.877
18/26 HF 323	2.377	2.377
18/26 HF 324	2.377	2.877
18/26 HF 325	2.877	2.377
18/26 HF 326	2.877	2.877
18/26 HF 327	2.877	3.377
18/26 HF 328	2.877	3.877
18/26 HF 329	3.877	3.377
18/26 HF 330	3.877	3.877

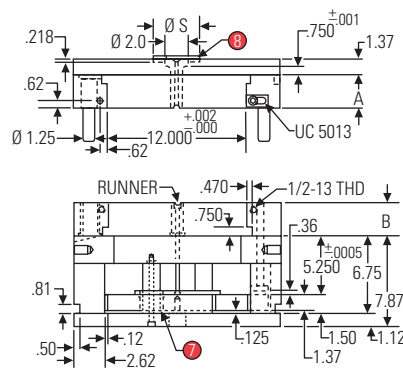

Ordering and installing information for H frame and companion insert molds can be found in the front of this section.

See front of this section for standard and optional frame

MUD® Quick-Change Mold Frames and Inserts for H-Style | 18/26 HF

Companion Interchangeable Insert Molds

- 1 Frame clamps at this end of insert mold and ejector plates are flush with this end of insert.
- 2 Support post not supplied. Grind +.001 to +.002 higher than height of ejection (see page C 131).
- 3 Thicker plate optional (quotation on request).
- 4 3/4 x 5° lead this end.

Standard Solid Construction

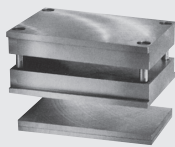

ITEM NO.	A	B
18/26 SSH 221	1.877	2.377
18/26 SSH 222	2.377	1.877
18/26 SSH 223	2.377	2.377
18/26 SSH 224	2.377	2.877
18/26 SSH 225	2.877	2.377
18/26 SSH 226	2.877	2.877
18/26 SSH 227	2.877	3.377
18/26 SSH 228	2.877	3.877
18/26 SSH 229	3.877	3.377
18/26 SSH 230	3.877	3.877

Standard Laminated Construction

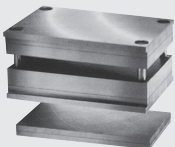

ITEM NO.	A	A2	B2	B
18/26 SLH 283	2.377	0.877	0.877	2.377
18/26 SLH 284	2.377	0.877	1.377	2.877
18/26 SLH 285	2.877	1.377	0.877	2.377
18/26 SLH 286	2.877	1.377	1.377	2.877
18/26 SLH 287	2.877	1.377	1.877	3.377
18/26 SLH 288	2.877	1.377	2.377	3.877
18/26 SLH 289	3.877	2.377	1.877	3.377
18/26 SLH 290	3.877	2.377	2.377	3.877

Standard Solid: 12.0 x 12.0

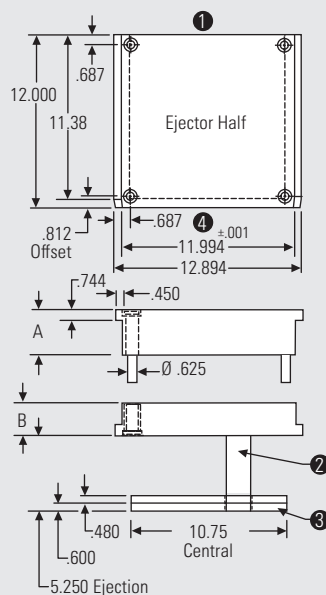

Standard Laminated: 12.0 x 12.0

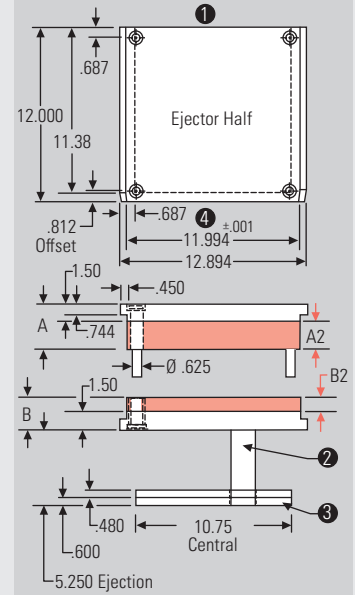

HF Quick-Change H-Style Frame & Companion Insert Molds

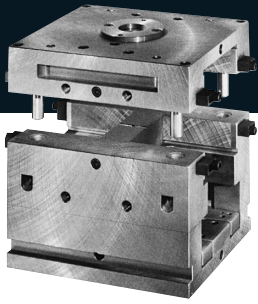

- 1 3/4-10 handling holes supplied standard as shown.
- 2 Ejector system designed for spring loading (quotation on request).
- 3 Waterlines in center sections optional (quotation on request).
- 4 Cutout in ejector plate to accommodate pillar post supplied standard as shown.
- 5 1 1/8 diameter knockouts supplied standard at center and 3.50 off center.
- 6 1/2-13 THD at knockout locations standard as shown.
- 7 Positive ejector plate guidance.
- 8 Locking locating ring supplied standard as shown.

"H" Style Quick-Change Frame

ITEM NO.	A	B
18/30 HF 321	1.877	2.377
18/30 HF 322	2.377	1.877
18/30 HF 323	2.377	2.377
18/30 HF 324	2.377	2.877
18/30 HF 325	2.877	2.377
18/30 HF 326	2.877	2.877
18/30 HF 327	2.877	3.377
18/30 HF 328	2.877	3.877
18/30 HF 329	3.877	3.377
18/30 HF 330	3.877	3.877

Ordering and installing information for H frame and companion insert molds can be found in the front of this section.

See front of this section for standard and optional frame

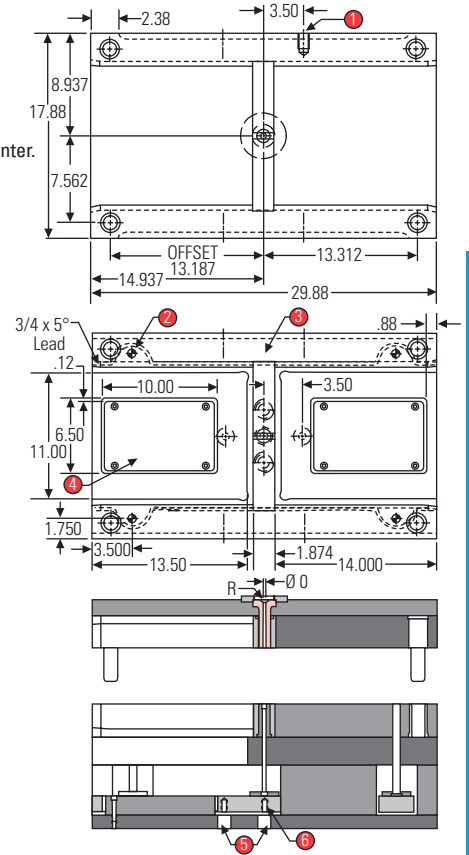
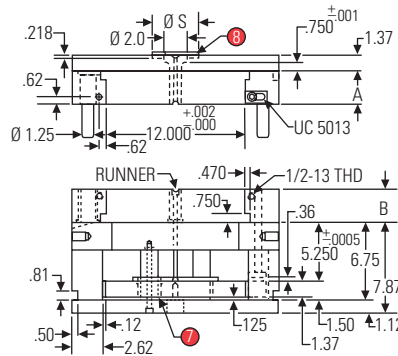

Companion Interchangeable Insert Molds

- 1 Frame clamps at this end of insert mold and ejector plates are flush with this end of insert.
- 2 Support post not supplied. Grind +.001 to +.002 higher than height of ejection (see page C 131).
- 3 Thicker plate optional (quotation on request).
- 4 3/4 x 5° lead this end.

Standard Solid:
12.0 x 14.0

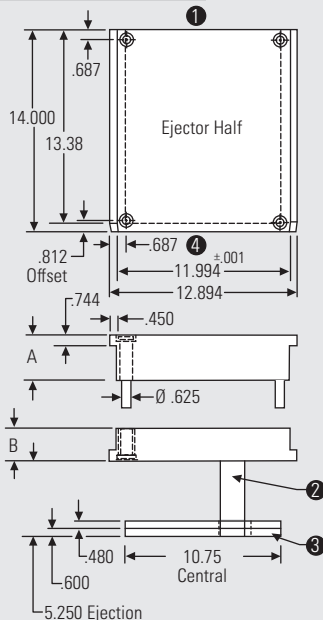

Standard Laminated:
12.0 x 14.0

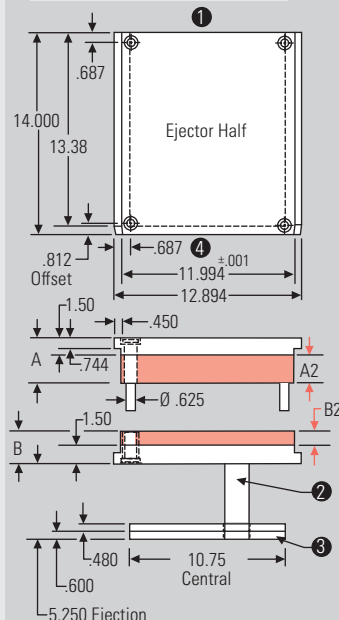

Standard Solid Construction

ITEM NO.	A	B
18/30 SSH 221	1.877	2.377
18/30 SSH 222	2.377	1.877
18/30 SSH 223	2.377	2.377
18/30 SSH 224	2.377	2.877
18/30 SSH 225	2.877	2.377
18/30 SSH 226	2.877	2.877
18/30 SSH 227	2.877	3.377
18/30 SSH 228	2.877	3.877
18/30 SSH 229	3.877	3.377
18/30 SSH 230	3.877	3.877

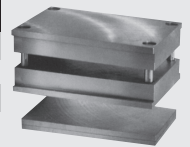

Standard Laminated Construction

ITEM NO.	A	A2	B2	B
18/30 SLH 283	2.377	0.877	0.877	2.377
18/30 SLH 284	2.377	0.877	1.377	2.877
18/30 SLH 285	2.877	1.377	0.877	2.377
18/30 SLH 286	2.877	1.377	1.377	2.877
18/30 SLH 287	2.877	1.377	1.877	3.377
18/30 SLH 288	2.877	1.377	2.377	3.877
18/30 SLH 289	3.877	2.377	1.877	3.377
18/30 SLH 290	3.877	2.377	2.377	3.877

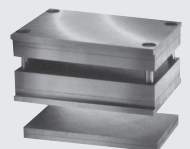

E-Style Mold Frame

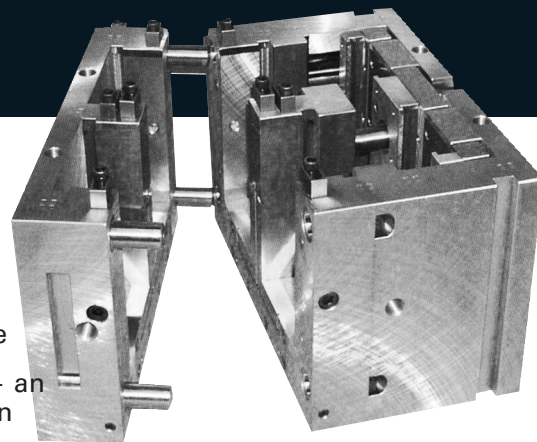

E-Style Mold Frame benefits and options

- Accepts the same size insert molds as the MUD®H style frame
- Features top loading of inserts from one overhead location — an easier, safer method of loading large, heavy insert molds than horizontal loading
- Accepts two standard MUD insert molds
- Offers the same available options as the MUD®H style frame
- Optional runner system allows standard gating to the side or end of the molds controlled by a simple turn of runner shut-off at the sprue injection site
- Optional temperature control lines in the frame
- Optional spring loading of master ejector plate system
- Optional positive return rails
- Optional hot sprue bushings
- Optional insulation board
- All E-Style Frames are special order (quotation on request)

Standard “E” Style Mold Frame Sizes with their Corresponding “H” Frame Interchangeable Insert

E FRAME	H FRAME INSERT
18/11 EF	10/18 HF
20/11 EF	11/18 HF
22/11 EF	12/19 HF
24/11 EF	13/19 HF
24/13 EF	13/23 HF
26/11 EF	14/19 HF
26/12 EF	14/21 HF
26/14 EF	14/25 HF
28/11 EF	15/19 HF
28/12 EF	15/21 HF
28/14 EF	15/25 HF
31/12 EF	17/19 HF
31/15 EF	17/26 HF
33/13 EF	18/22 HF
33/15 EF	18/26 HF
33/17 EF	18/30 HF

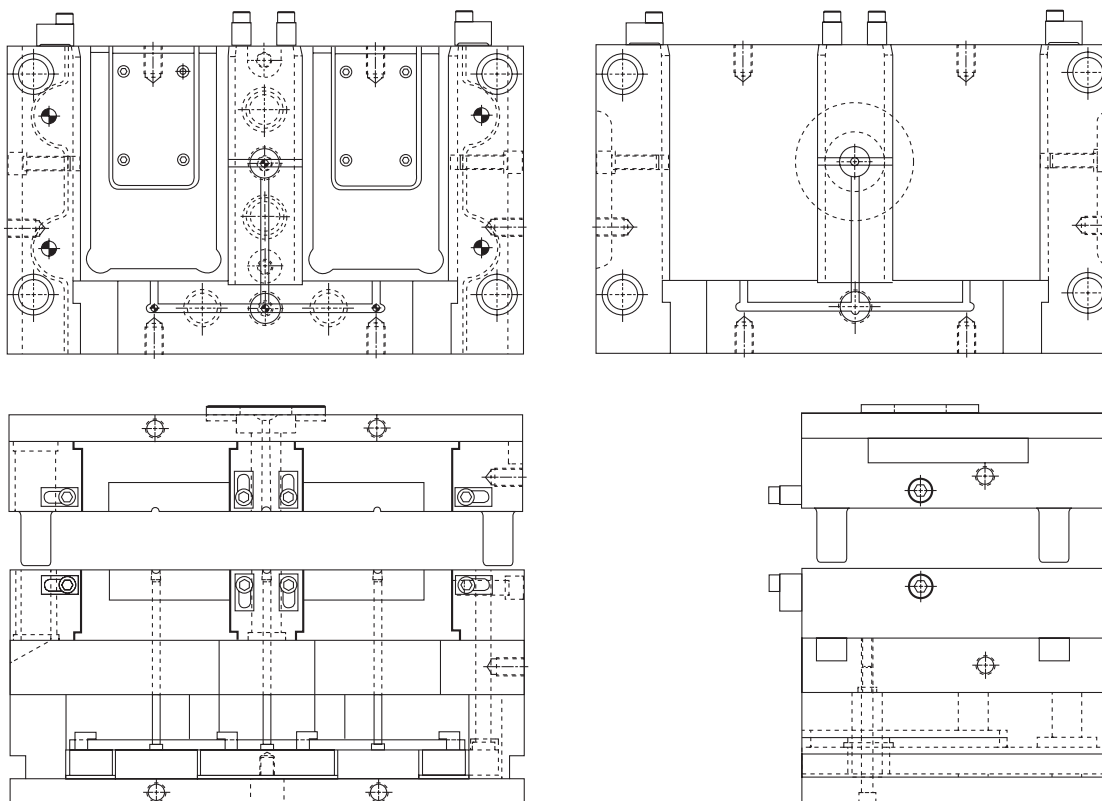



Quick-Change Mold Frames & Inserts for Double H-Style

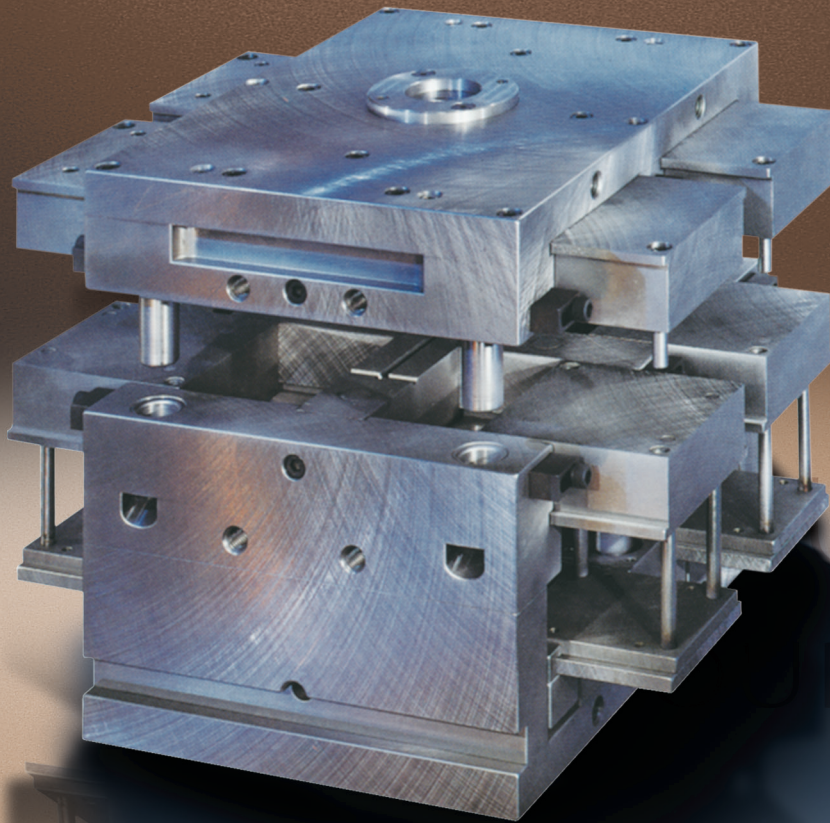

Frame Ordering Information

- Item number and description (see tables on respective page)
- "S" diameter of locating ring supplied standard 3.990" (see illustrations on respective page)
- Sprue specification "R" spherical radius of sprue bushing furnished 1/2" or 3/4" unless otherwise shown
- "O" small diameter of sprue bushing orifice furnished 5/32", 7/32", 9/32" or 11/32", unless otherwise shown
- Optional locating rings available on request
- Knockout hole location standard as shown (others optional)
- Runner size and description
- Cutouts in master ejector plate for insert mold pillar posts standard as shown on respective page
- Clamp slots standard unless otherwise shown on respective page
- Mounting holes optional unless shown on respective page

Insert Mold Ordering Information

- Item number and description (see tables on respective page)
- Steel grades – 1020, 4130 prehard, P-20 prehard and H-13: 420 stainless and other grades on request
- H-13 and other tool steel insert molds supplied .010 oversize on outside dimensions, .010 – .013 oversize on thickness, and .025 – .035 undersize in the pin and bushing holes for machining after required heat treating
- "A" and "B" dimensions supplied .004 – .007 oversize unless otherwise specified

NOTE: The "A" and "B" dimensions for insert mold must match those of the companion Double H frame.

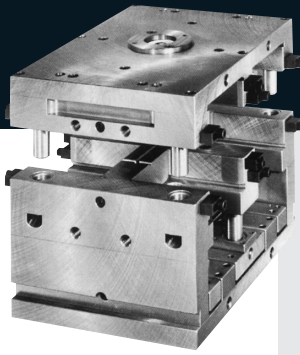

Quick-Change Double H frame features and applications

This MUD® Quick-Change frame series features a fixed center runner bar for simultaneous molding with four standard-style companion insert molds. The series offers cost reduction benefits and time-saving advantages similar to the U frame and H frame series. It also provides comparable design flexibility.

Each of the four companion insert molds for Double H frames can be changed individually and independently. Dummy inserts or runner shutoffs are available for molding with fewer than four insert molds. These features give the Double H frame series maximum versatility for tailoring production to inventory requirements including just-in-time scheduling.

Double H frames also offer special advantages for high volume production. Simultaneous molding with four insert molds quadruples quantities for each cycle. Also, there is virtually no need to interrupt production for maintenance or repair since inexpensive backup insert molds can be installed quickly.

Double H frames are supplied with hardened center runner bars and replaceable sprue puller pin assemblies. Each frame includes a locking locating ring and an integral master ejector plate with cutouts to allow installation of insert mold pillar posts. The master ejector plate is also supplied with positive aligning guide posts, bushings and grease fittings for a guided ejector system.

Options include interlocking ejector rails to lock the insert mold's ejector system to the master ejector plate. The master ejector plate can be spring loaded for returning the insert mold's ejector system. It can also be tied to the machine's hydraulic knockout system for stroking the insert mold's ejector assembly.

Other options include water lines in the center bar or other locations, insulation boards, runner shutoffs and hot sprue bushings. Frame spacer bars to accommodate shorter, more economical companion insert molds are available for frames designed for longer sizes. Additional retainer slots and a spacer plate in the frame's cavity half allow the frame to accept insert molds with different thicknesses.

Quick-Change Hot Runner Molding

All of the advantages of the MUD® Quick-Change Concept can be added to a hot runner molding system with the addition of a manifold to the Double H frame. Both the frame and the hot runner system remain in the molding machine. Only the insert molds are changed to produce new parts, just as in other Quick-Change applications. This means faster changeovers, lower tooling costs and greater scheduling flexibility for hot runner molding.

Steel specifications: Standard frames are produced in prehard steel (285-325 Brinell) with hardened center sections. Frames are also available in prehard stainless, 420 stainless, H-13 and other grades on request. Frame coating can be specified.

Quick-Change Double H frame options

- Spring-loaded master ejector plates
- Interlocking ejector rails
- Additional height on ejector rails
- Early return on ejector system
- Special knockout hole locations
- Runner shutoffs
- Choice of runner configuration
- Frame spacer bars
- Insulation boards
- Additional retainer slot and spacer plate
- Water lines for center sections
- Water lines for rails and plates
- Machining for cartridge heaters
- Manifold for hot runner operation
- Hot sprue bushings
- Coating options
- Electroless nickel plating

NOTE: Specifications subject to change without prior notice.



Companion insert mold features and applications

Standard style companion insert molds for Double H frames are available in solid or laminated construction and include three- and four-plate designs.

Insert mold options include machining for stripper plates, sleeve ejection, return pins and pillar posts. Machining for cartridge heater holes, water lines, taper locks, rough and finished custom pockets and other special applications is available.

Design options for insert molds include spring loading, early return, unscrewing mechanisms, hot runner molding and machining for cam slides. Insert molds can be ordered with interlocking ejector plates for positive return and stroking action when used with frames having an interlocking ejector system.

Steel specifications: Companion insert molds are available in 1020, 4130 prehard, P-20 prehard and H-13. 420 stainless and other grades are available on request.

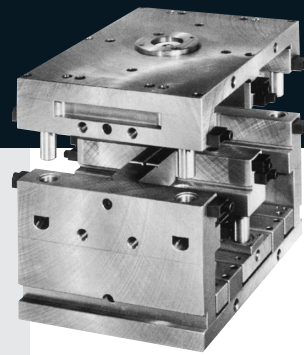
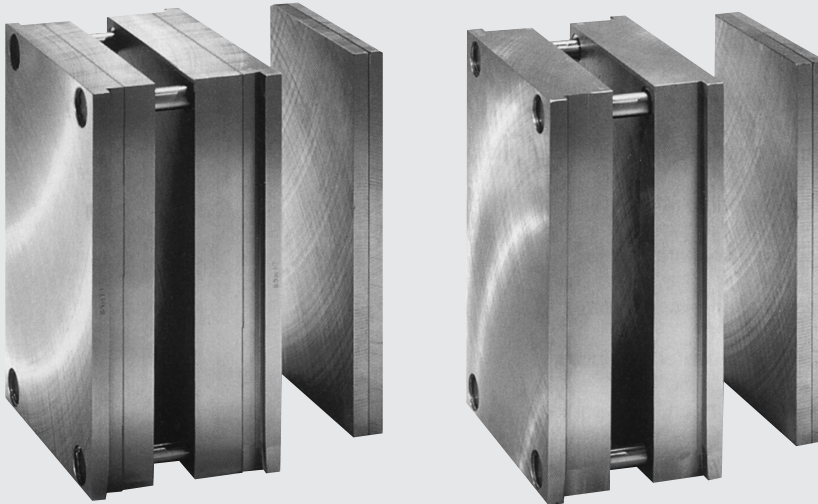

Companion insert mold options

- Solid or laminated construction
- Stripper plates
- Interlocking ejector plates
- Return pins
- Pillar posts
- Sleeve ejection
- Machining for taper locks
- Machining for cartridge heater holes
- Machining for water lines
- Rough cut pockets
- Finished custom pockets
- Machining for special applications

NOTE: Specifications subject to change without prior notice.



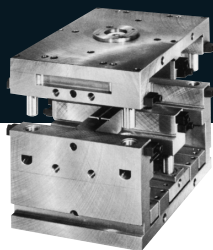

DF Quick-Change DH-Style Frame & Companion Insert Molds

MUD® Quick-Change Mold Frames and Inserts for Double H-Style 12/08 DF

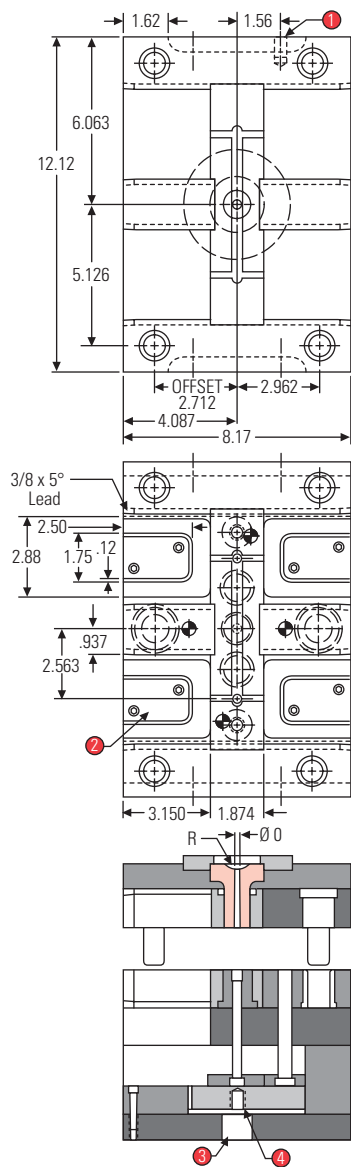

STANDARD SOLID INSERT MOLD

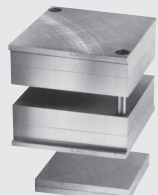

STANDARD LAMINATED INSERT MOLD

Standard Solid:
3.25 x 3.15

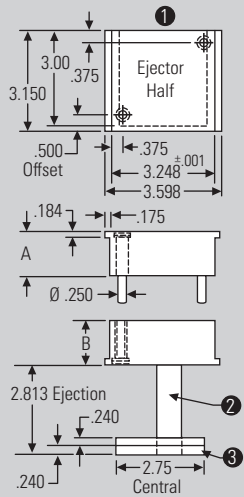

Standard Laminated:
3.25 x 3.15

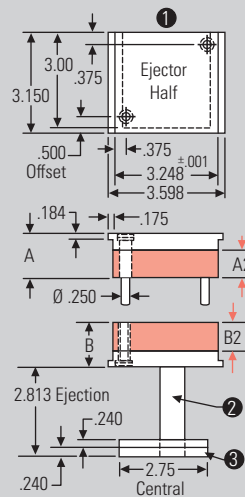

Companion Interchangeable

- 1 Frame clamps at this end of insert mold and ejector plates are flush with this end of insert.
- 2 Support post not supplied. Grind $\pm .001$ to $\pm .002$ higher than height of ejection (see page C 131).
- 3 Thicker plate optional (quotation on request).

Double "H" Style Quick-Change Frame

ITEM NO.	A	B
12/08 DF 321	1.377	1.377
12/08 DF 322	1.877	1.377
12/08 DF 323	1.877	1.877
12/08 DF 324	2.377	1.877

Standard Laminated Construction

ITEM NO.	A	A2	B2	B
12/08 SLD 281	1.377	0.877	0.877	1.377
12/08 SLD 282	1.877	1.377	0.877	1.377
12/08 SLD 283	1.877	1.377	1.377	1.877
12/08 SLD 284	2.377	1.877	1.377	1.877

Standard Solid Construction

ITEM NO.	A	B
12/08 SSD 221	1.377	1.377
12/08 SSD 222	1.877	1.377
12/08 SSD 223	1.877	1.877
12/08 SSD 224	2.377	1.877

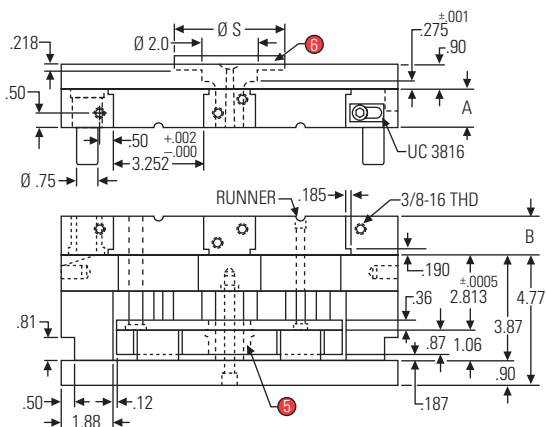

- 1 1/2-13 handling holes supplied standard as shown.
- 2 Cutout in ejector plate to accommodate pillar post supplied standard as shown.
- 3 1 1/8 diameter knockouts supplied standard at center and 3.50 off center.
- 4 1/2-13 THD at knockout locations standard as shown.
- 5 Positive ejector plate guidance.
- 6 Locking locating ring supplied standard as shown.

Ordering and installing information for Double H frame and companion insert molds can be found in the front of this section.

See front of this section for standard and optional frame features.



DF Quick-Change DH-Style Frame & Companion Insert Molds

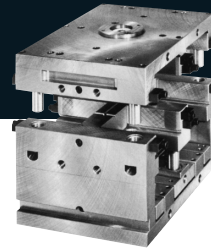

Standard Solid:
5.0 x 3.5

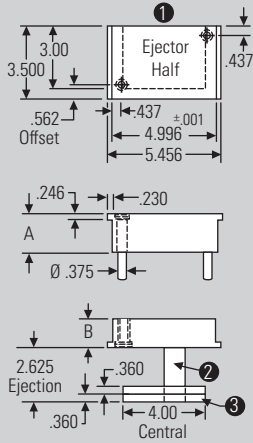

Standard Laminated:
5.0 x 3.5

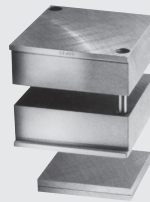
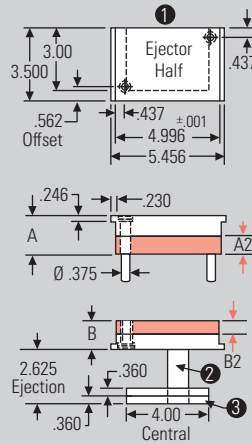

STANDARD SOLID
INSERT MOLD

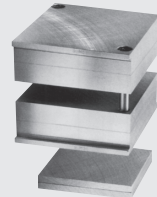

STANDARD LAMINATED
INSERT MOLD

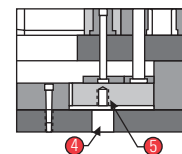
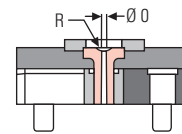
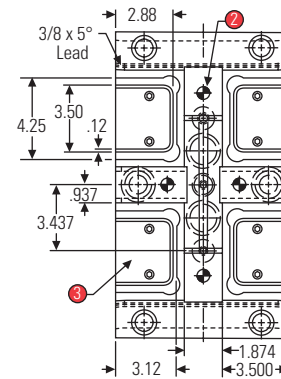
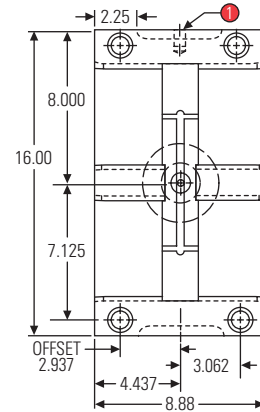

Double "H" Style Quick-Change Frame

ITEM NO.	A	B
16/09 DF 321	1.877	1.377
16/09 DF 322	1.877	1.877
16/09 DF 323	2.377	1.877

Companion Interchangeable

- 1 Frame clamps at this end of insert mold and ejector plates are flush with this end of insert.
- 2 Support post not supplied. Grind +.001 to +.002 higher than height of ejection (see page C 131).
- 3 Thicker plate optional (quotation on request).

Standard Solid Construction

ITEM NO.	A	B
16/09 SSD 221	1.877	1.377
16/09 SSD 222	1.877	1.877
16/09 SSD 223	2.377	1.877

Standard Laminated Construction

ITEM NO.	A	A2	B2	B
16/09 SLD 281	1.877	0.877	0.877	1.377
16/09 SLD 282	1.877	0.877	0.877	1.877
16/09 SLD 283	2.377	1.377	0.877	1.877

- 1 5/8-11 handling holes supplied standard as shown.
- 2 Ejector system designed for spring loading (quotation on request).
- 3 Cutout in ejector plate to accommodate pillar post supplied standard as shown.
- 4 1 1/8 diameter knockouts supplied standard at center and 3.50 off center.
- 5 1/2-13 THD at knockout locations standard as shown.
- 6 Positive ejector plate guidance.
- 7 Locking locating ring supplied standard as shown.

Ordering and installing information for Double H frame and companion insert molds can be found in the front of this section.

See front of this section for standard and optional frame features.

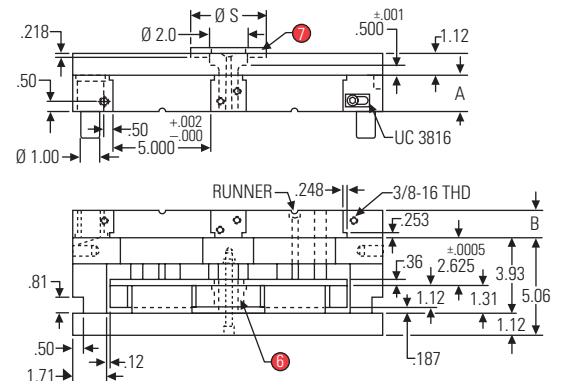

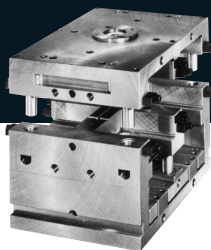

DF Quick-Change DH-Style Frame & Companion Insert Molds

MUD® Quick-Change Mold Frames and Inserts for Double H-Style 16/12 DF

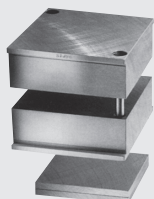
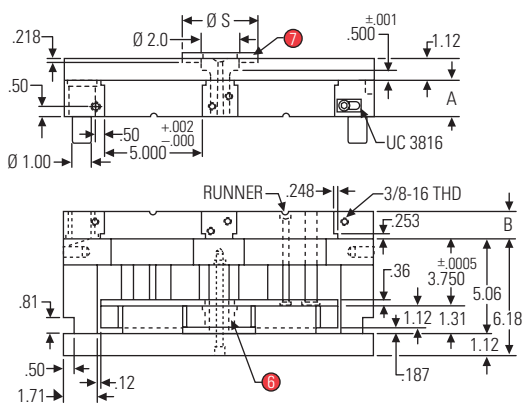
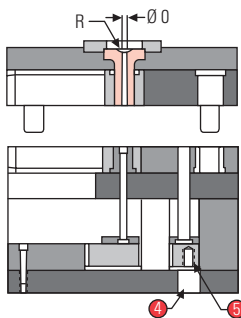
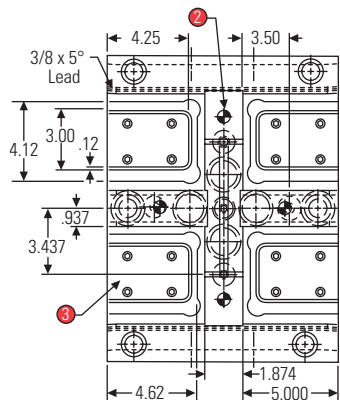
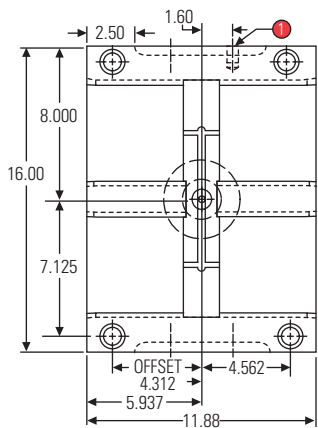

STANDARD SOLID INSERT MOLD

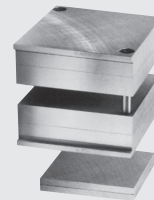

STANDARD LAMINATED INSERT MOLD

Standard Solid:
5.0 x 5.0

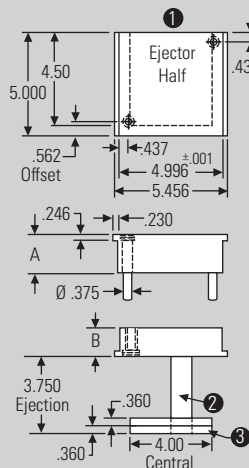

Standard Laminated:
5.0 x 5.0

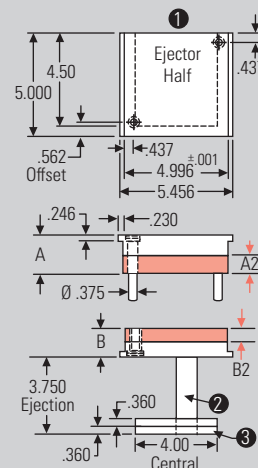

Companion Interchangeable

- 1 Frame clamps at this end of insert mold and ejector plates are flush with this end of insert.
- 2 Support post not supplied. Grind +.001 to +.002 higher than height of ejection (see page C 131).
- 3 Thicker plate optional (quotation on request).

Double "H" Style Quick-Change Frame

ITEM NO.	A	B
16/12 DF 321	1.877	1.377
16/12 DF 322	1.877	1.877
16/12 DF 323	1.877	2.377
16/12 DF 324	2.377	1.877
16/12 DF 325	2.377	2.377

Standard Laminated Construction

ITEM NO.	A	A2	B2	B
16/12 SLD 281	1.877	0.877	0.877	1.377
16/12 SLD 282	1.877	0.877	0.877	1.877
16/12 SLD 283	1.877	0.877	1.377	2.377
16/12 SLD 284	2.377	1.377	0.877	1.877
16/12 SLD 285	2.377	1.377	1.377	2.377

Standard Solid Construction

ITEM NO.	A	B
16/12 SSD 221	1.877	1.377
16/12 SSD 222	1.877	1.877
16/12 SSD 223	1.877	2.377
16/12 SSD 224	2.377	1.877
16/12 SSD 225	2.377	2.377

- 1 5/8-11 handling holes supplied standard as shown.
- 2 Ejector system designed for spring loading (quotation on request).
- 3 Cutout in ejector plate to accommodate pillar post supplied standard as shown.
- 4 1 1/8 diameter knockouts supplied standard at center and 3.50 off center.
- 5 1/2-13 THD at knockout locations standard as shown.
- 6 Positive ejector plate guidance.
- 7 Locking locating ring supplied standard as shown.

Ordering and installing information for Double H frame and companion insert molds can be found in the front of this section. See front of this section for standard and optional frame features.



DF Quick-Change DH-Style Frame & Companion Insert Molds

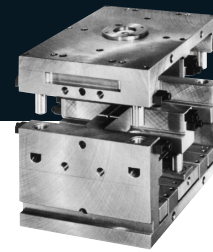

Standard Solid:
5.0 x 8.0

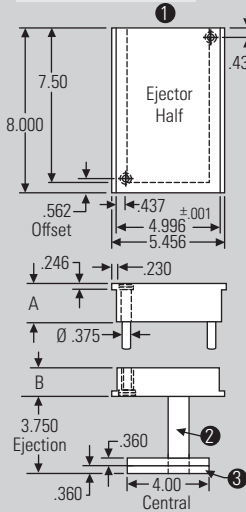

Standard Laminated:
5.0 x 8.0

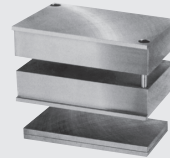
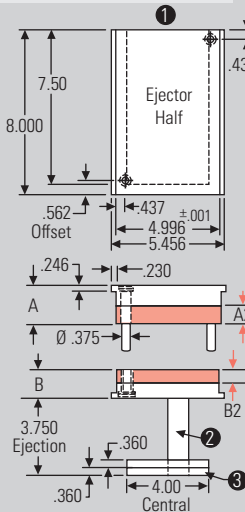

STANDARD SOLID
INSERT MOLD

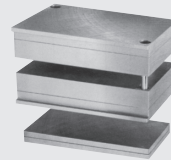

STANDARD LAMINATED
INSERT MOLD

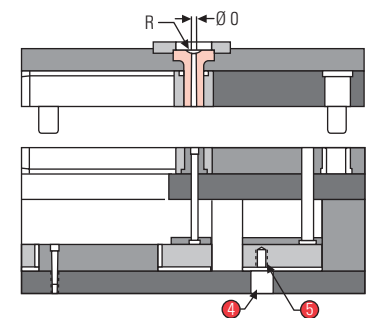
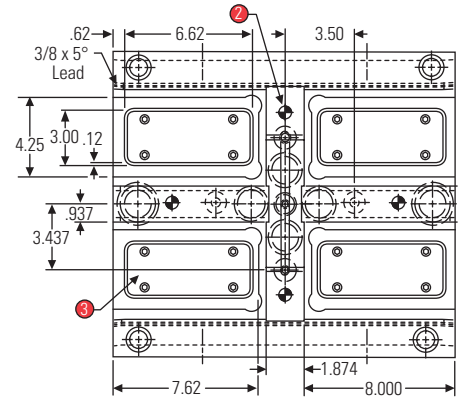
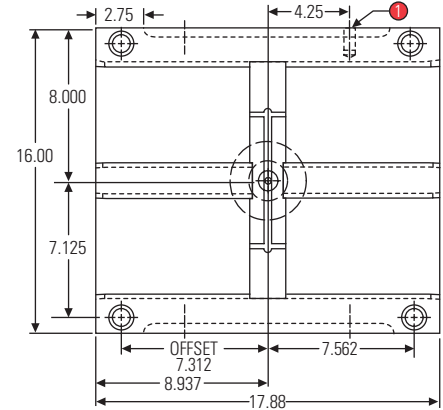

Double "H" Style Quick-Change Frame

ITEM NO.	A	B
16/18 DF 321	1.877	1.377
16/18 DF 322	1.877	1.877
16/18 DF 323	1.877	2.377
16/18 DF 324	2.377	1.877
16/18 DF 325	2.377	2.377
16/18 DF 326	2.377	2.877
16/18 DF 327	2.877	2.377
16/18 DF 328	2.877	2.877

Companion Interchangeable

- 1 Frame clamps at this end of insert mold and ejector plates are flush with this end of insert.
- 2 Support post not supplied. Grind $\pm .001$ to $\pm .002$ higher than height of ejection (see page C 131).
- 3 Thicker plate optional (quotation on request).

Standard Solid Construction

ITEM NO.	A	B
16/18 SSD 221	1.877	1.377
16/18 SSD 222	1.877	1.877
16/18 SSD 223	1.877	2.377
16/18 SSD 224	2.377	1.877
16/18 SSD 225	2.377	2.377
16/18 SSD 226	2.377	2.877
16/18 SSD 227	2.877	2.377
16/18 SSD 228	2.877	2.877

Standard Laminated Construction

ITEM NO.	A	A2	B2	B
16/18 SLD 281	1.877	0.877	0.877	1.377
16/18 SLD 282	1.877	0.877	0.877	1.877
16/18 SLD 283	1.877	0.877	1.377	2.377
16/18 SLD 284	2.377	1.377	0.877	1.877
16/18 SLD 285	2.377	1.377	1.377	2.377
16/18 SLD 286	2.377	1.377	1.877	2.877
16/18 SLD 287	2.877	1.877	1.377	2.377
16/18 SLD 288	2.877	1.877	1.877	2.877

- 1 3/4-10 handling holes supplied standard as shown.
- 2 Ejector system designed for spring loading (quotation on request).
- 3 Cutout in ejector plate to accommodate pillar post supplied standard as shown.
- 4 1 1/8 diameter knockouts supplied standard at center and 3.50 off center.
- 5 1/2-13 THD at knockout locations standard as shown.
- 6 Positive ejector plate guidance.
- 7 Locking locating ring supplied standard as shown.

Ordering and installing information for Double H frame and companion insert molds can be found in the front of this section.
See front of this section for standard and optional frame features.

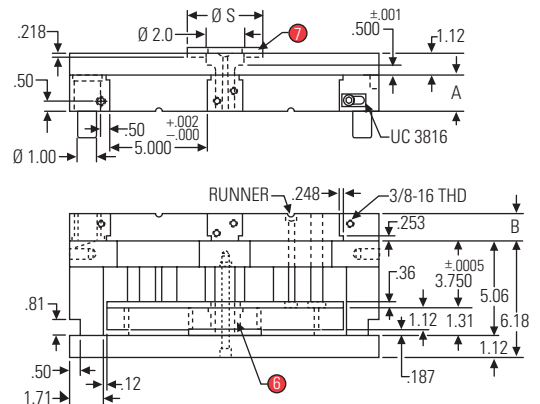

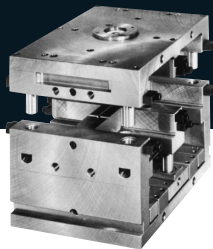

DF Quick-Change DH-Style Frame & Companion Insert Molds

MUD® Quick-Change Mold Frames and Inserts for Double H-Style 20/14 DF

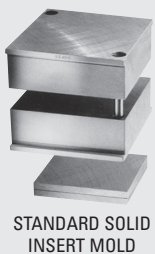
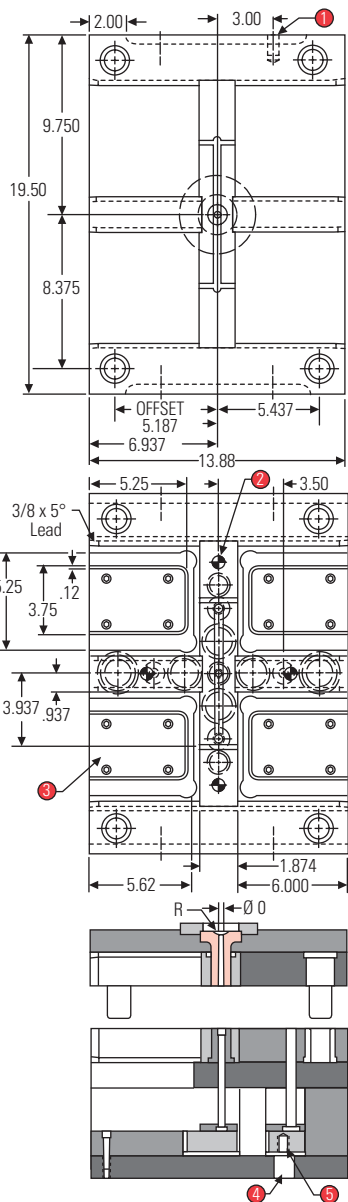

Standard Solid:
6.0 x 6.0

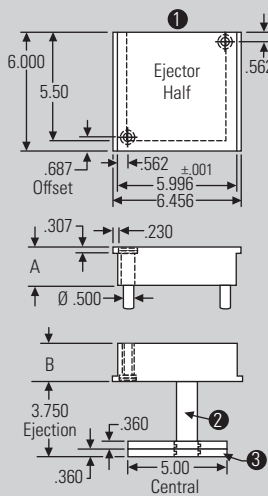

Standard Laminated:
6.0 x 6.0

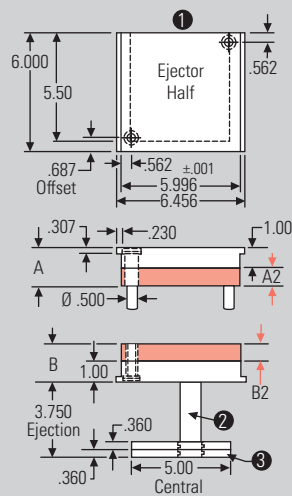

Companion Interchangeable

- 1 Frame clamps at this end of insert mold and ejector plates are flush with this end of insert.
- 2 Support post not supplied. Grind +.001 to +.002 higher than height of ejection (see page C 131).
- 3 Thicker plate optional (quotation on request).

Double "H" Style Quick-Change Frame

ITEM NO.	A	B
20/14 DF 322	1.877	1.877
20/14 DF 323	2.377	1.877
20/14 DF 324	2.377	2.377
20/14 DF 325	2.877	2.377
20/14 DF 326	2.877	2.877

Standard Laminated Construction

ITEM NO.	A	A2	B2	B
20/14 SLD 282	1.877	0.877	0.877	1.877
20/14 SLD 283	2.377	1.377	0.877	1.877
20/14 SLD 284	2.377	1.377	1.377	2.377
20/14 SLD 285	2.877	1.877	1.377	2.377
20/14 SLD 286	2.877	1.877	1.877	2.877

Standard Solid Construction

ITEM NO.	A	B
20/14 SSD 222	1.877	1.877
20/14 SSD 223	2.377	1.877
20/14 SSD 224	2.377	2.377
20/14 SSD 225	2.877	2.377
20/14 SSD 226	2.877	2.877

- 1 3/4-10 handling holes supplied standard as shown.
- 2 Ejector system designed for spring loading (quotation on request).
- 3 Cutout in ejector plate to accommodate pillar post supplied standard as shown.
- 4 1 1/8 diameter knockouts supplied standard at center and 3.50 off center.
- 5 1/2-13 THD at knockout locations standard as shown.
- 6 Positive ejector plate guidance.
- 7 Locking locating ring supplied standard as shown.

Ordering and installing information for Double H frame and companion insert molds can be found in the front of this section.

See front of this section for standard and optional frame features.



DF Quick-Change DH-Style Frame & Companion Insert Molds

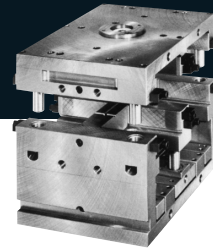

Standard Solid:
7.0 x 8.5

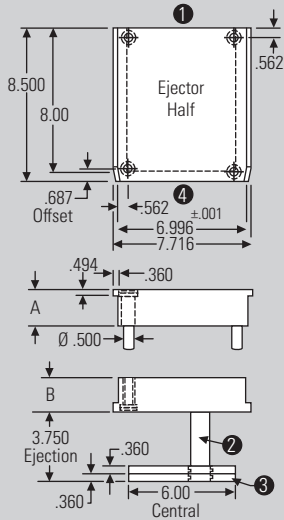

Standard Laminated:
7.0 x 8.5

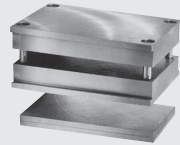
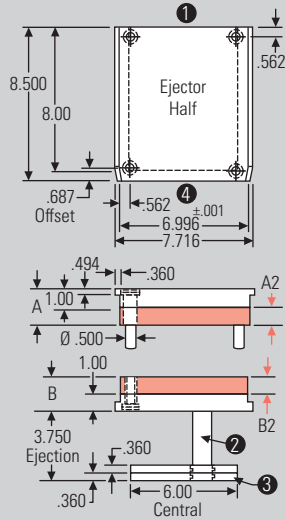

STANDARD SOLID
INSERT MOLD

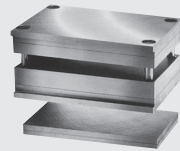

STANDARD LAMINATED
INSERT MOLD

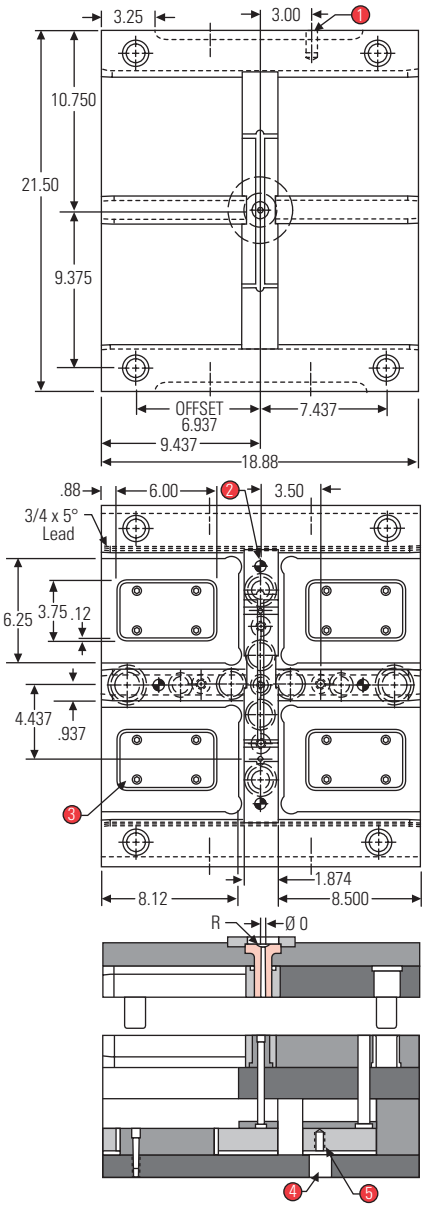

Double "H" Style Quick-Change Frame

ITEM NO.	A	B
22/19 DF 321	1.877	1.877
22/19 DF 322	1.877	2.377
22/19 DF 323	2.377	1.877
22/19 DF 324	2.377	2.377

Companion Interchangeable

- 1 Frame clamps at this end of insert mold and ejector plates are flush with this end of insert.
- 2 Support post not supplied. Grind +.001 to +.002 higher than height of ejection (see page C 131).
- 3 Thicker plate optional (quotation on request).
- 4 3/4 x 5° lead this end.

Standard Solid Construction

ITEM NO.	A	B
22/19 SSD 221	1.877	1.877
22/19 SSD 222	1.877	2.377
22/19 SSD 223	2.377	1.877
22/19 SSD 224	2.377	2.377

Standard Laminated Construction

ITEM NO.	A	A2	B2	B
22/19 SLD 281	1.877	0.877	0.877	1.877
22/19 SLD 282	1.877	0.877	1.377	2.377
22/19 SLD 283	2.377	1.377	0.877	1.877
22/19 SLD 284	2.377	1.377	1.377	2.377

- 1 3/4-10 handling holes supplied standard as shown.
- 2 Ejector system designed for spring loading (quotation on request).
- 3 Cutout in ejector plate to accommodate pillar post supplied standard as shown.
- 4 1 1/8 diameter knockouts supplied standard at center and 3.50 off center.
- 5 1/2-13 THD at knockout locations standard as shown.
- 6 Positive ejector plate guidance.
- 7 Locking locating ring supplied standard as shown.

Ordering and installing information for Double H frame and companion insert molds can be found in the front of this section. See front of this section for standard and optional frame features.

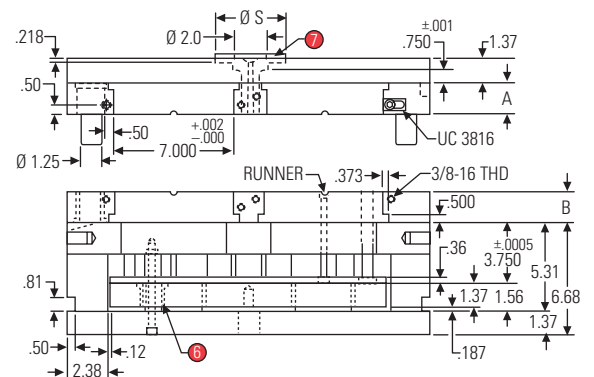

DF Quick-Change DH-Style Frame & Companion Insert Molds

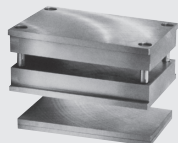
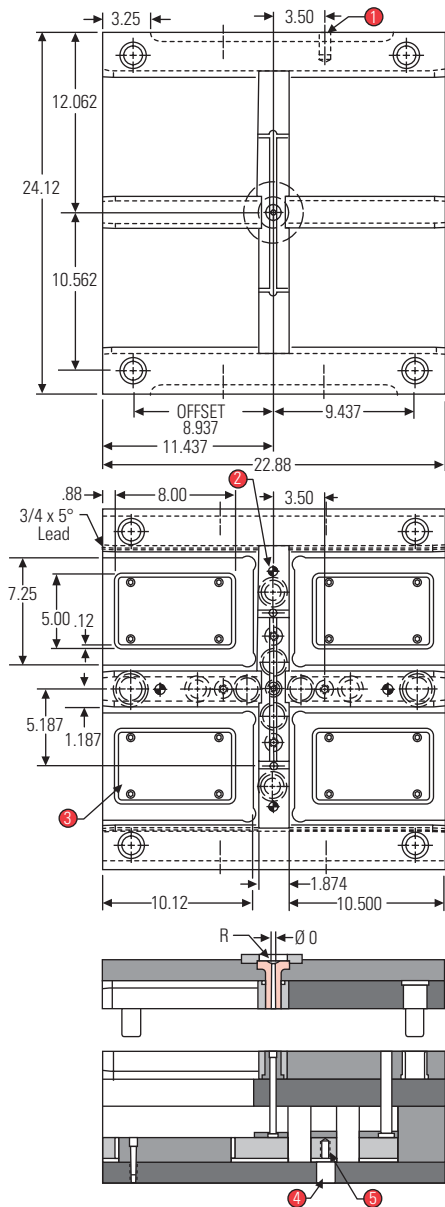
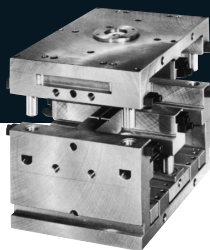

STANDARD SOLID INSERT MOLD

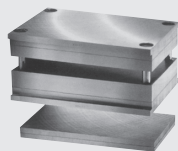

STANDARD LAMINATED INSERT MOLD

Standard Solid: 8.0 x 10.5

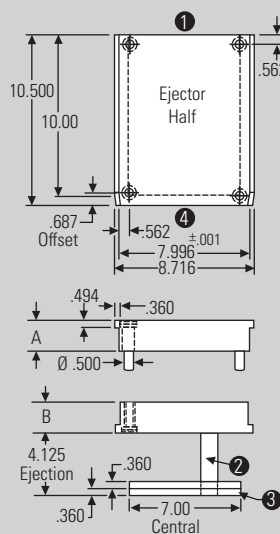

Standard Laminated: 8.0 x 10.5

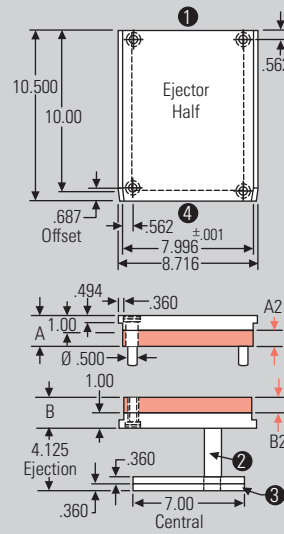

Companion Interchangeable

- 1 Frame clamps at this end of insert mold and ejector plates are flush with this end of insert.
- 2 Support post not supplied. Grind +.001 to +.002 higher than height of ejection (see page C 131).
- 3 Thicker plate optional (quotation on request).
- 4 3/4 x 5° lead this end.

Double "H" Style Quick-Change Frame

ITEM NO.	A	B
24/23 DF 321	1.877	1.877
24/23 DF 322	1.877	2.377
24/23 DF 323	2.377	1.877
24/23 DF 324	2.377	2.377
24/23 DF 325	2.377	2.877
24/23 DF 326	2.877	2.377
24/23 DF 327	2.877	2.877

Standard Laminated Construction

ITEM NO.	A	A2	B2	B
24/23 SLD 281	1.877	0.877	0.877	1.877
24/23 SLD 282	1.877	0.877	1.377	2.377
24/23 SLD 283	2.377	1.377	0.877	1.877
24/23 SLD 284	2.377	1.377	1.377	2.377
24/23 SLD 285	2.377	1.377	1.877	2.877
24/23 SLD 286	2.877	1.877	1.377	2.377
24/23 SLD 287	2.877	1.877	1.877	2.877

Standard Solid Construction

ITEM NO.	A	B
24/23 SSD 221	1.877	1.877
24/23 SSD 222	1.877	2.377
24/23 SSD 223	2.377	1.877
24/23 SSD 224	2.377	2.377
24/23 SSD 225	2.377	2.877
24/23 SSD 226	2.877	2.377
24/23 SSD 227	2.877	2.877

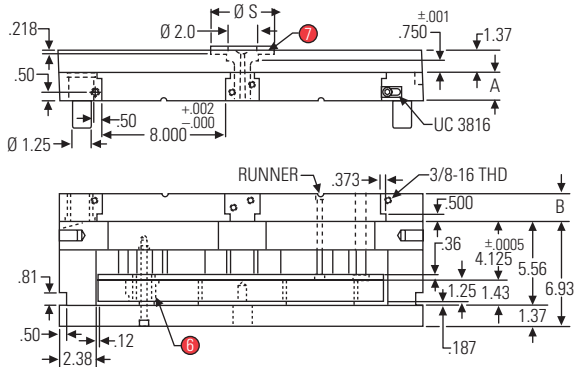

- 1 3/4-10 handling holes supplied standard as shown.
- 2 Ejector system designed for spring loading (quotation on request).
- 3 Cutout in ejector plate to accommodate pillar post supplied standard as shown.
- 4 1 1/8 diameter knockouts supplied standard at center and 3.50 off center.
- 5 1/2-13 THD at knockout locations standard as shown.
- 6 Positive ejector plate guidance.
- 7 Locking locating ring supplied standard as shown.

Ordering and installing information for Double H frame and companion insert molds can be found in the front of this section.

See front of this section for standard and optional frame features.



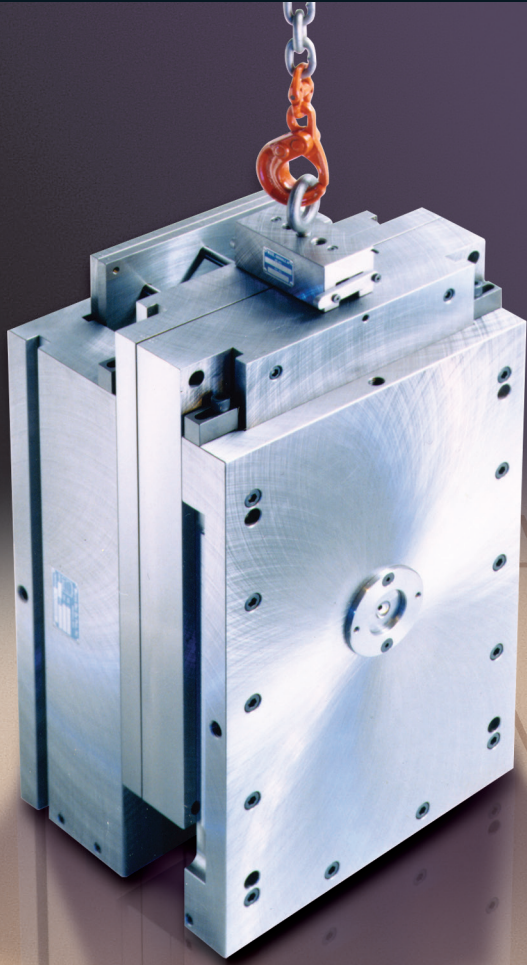

Quick-Change
Adapter Frame Systems for
Standard Mold Bases

ADAPTER FRAME
ADAPTER
ADAPTER FRAME

Frame Ordering Information

- Item number and description (see tables on respective page)
- Standard frames and ear plates are constructed of prehard steel. Prehard stainless and other steel grades available (quotation on request). Armorclad* can also be specified. Frame rails have been treated for enhanced wear resistance.
* "Armorclad" is the registered trademark of Armorclad, Inc.
- Ear plate sets include mounting holes, dowel holes, knockout holes and locating ring clearance holes as illustrated
- "S" supplied standard 3.990"
- Frame supplied standard with clamp slots
- Mounting screws optional; specify locations

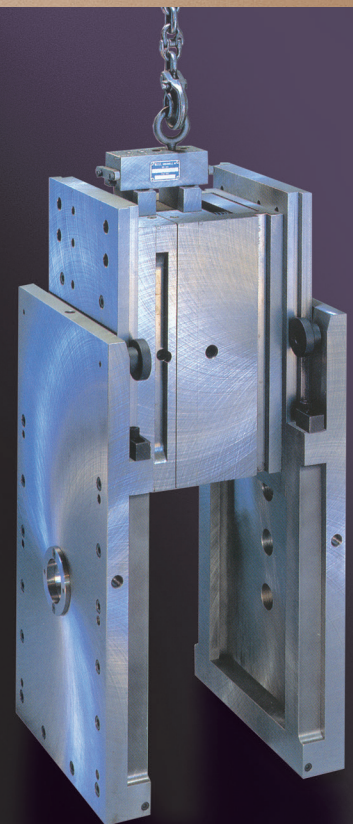

Adapter frame system accessories

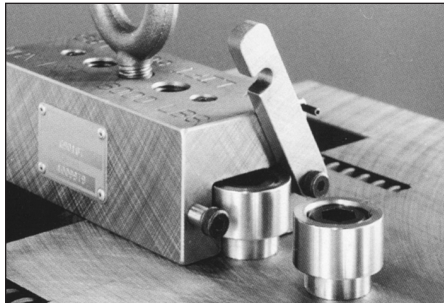

MUD® Balancing Lift Bars

These bars feature slide-and-lock attachment for fast positioning at the balance point of the standard mold base. This allows the mold base to be easily lowered in and raised out of the adapter frame. The bar fits over inexpensive buttons mounted on mold bases in place of eye bolts. Lifting bars and companion buttons are available in capacities to 5,140 pounds. (See page AF 103)

Quick Coupler KO Rod Systems

This optional assembly permits molding machines' hydraulic knockout systems to operate at their maximum stroke. The recommended system is based on three push points and one pull back. It locks the mold ejector system to the machine's hydraulic knockout system with a simple push and turn action. (See page AF 102)

NOTE: Specifications subject to change without prior notice.

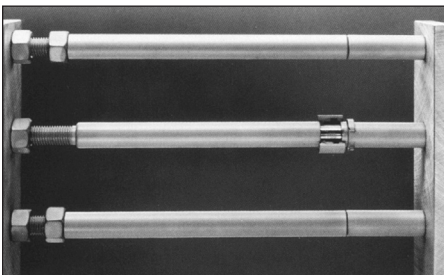

The Quick-Change concept for standard mold bases

Production changeovers in less than 10 minutes

Standard mold bases can be interchanged in less than 10 minutes with MUD's Quick-Change adapter frame system. It's the most economical quick-change system available and it works with any standard mold base in any molding machine up to 500-ton capacity.

The system is based on a Master Unit Die frame that remains in the molding machine during production changeovers. The frame is installed without modifying the machine. Standard mold bases equipped with companion ear plates are interchanged within this adapter frame.

Just one adapter frame accommodates an unlimited number of standard mold bases. While these frames can remain in the machine indefinitely, they are easily transferred to other machines. No other special mounting hardware is required.

The MUD® Quick-Change system is based on the unique slide and clamp approach to mold changeovers developed by Master Unit Die Products. Standard mold bases equipped with MUD® ear plate sets simply slide in and out of the Quick-Change adapter frame. Just one MUD® adapter frame is needed for each molding machine selected for Quick-Change operation.

Installation is fast. Simply clamp the Quick-Change adapter frame to the platens of any molding machine selected for Quick-Change operation. Companion ear plates are bolted to the standard mold bases to be interchanged in the machine. Both the machine and the standard mold bases are now ready for production changeovers in less than ten minutes.

MUD® Quick-Change adapter frames and companion ear plates are available in six standard sizes. Each accommodates a wide range of standard mold bases. Selecting the largest adapter frame that fits a molding machine allows interchanging of standard mold bases up to the machine's maximum capacity.



Companion ear plate installation instructions

Equipping standard mold bases with MUD® Quick-Change adapter system companion ear plates is a fast and easy procedure. The following steps are an efficient and recommended installation method.

Preparation

Before installing Master Unit Die Quick-Change adapter frame companion ear plates, inspect the plates for foreign matter and high spots (400 grit stone is recommended for removing high spots). After the plates are cleaned and free of burrs, spray the surfaces with a high quality mold protection. This aids in preventing build-up between the MUD® companion ear plates and the standard mold base.

Installation

STEP 1: Mount the ear plate to the cavity side of the standard mold base using the base's locating ring to locate the ear plate. Scale the side of the standard mold base in parallel to the ear plate and transfer the bolt holes. Then dowel the ear plate to the standard mold base.

STEP 2: Remove the ear plate from the standard mold base.

STEP 3: Set the cavity side ear plate on a machine capable of locating holes $\pm .001$. Strap the ear plate on the machine, top side down. Indicate the runner side of the ear plate in straight.

STEP 4: Use indicator to find center of locating ring hole.

STEP 5: Place the two dowel pins in the plate or the standard mold base and set it on the ear plate.

STEP 6: Strap the standard mold base on the machine.

STEP 7: Install the ejector side ear plate bolt and dowel pin holes as indicated on the ear plate print.

STEP 8: Ear plates can be installed on each individual standard mold base for the most efficient production changeovers, or they can be transferred from one standard mold base to another.

STEP 9: After the companion ear plates are installed on a standard mold base and the adapter frame is installed in the molding machine, the MUD® Quick-Change adapter frame system is ready for operation. Mold changes can now be made in as little as six to ten minutes.

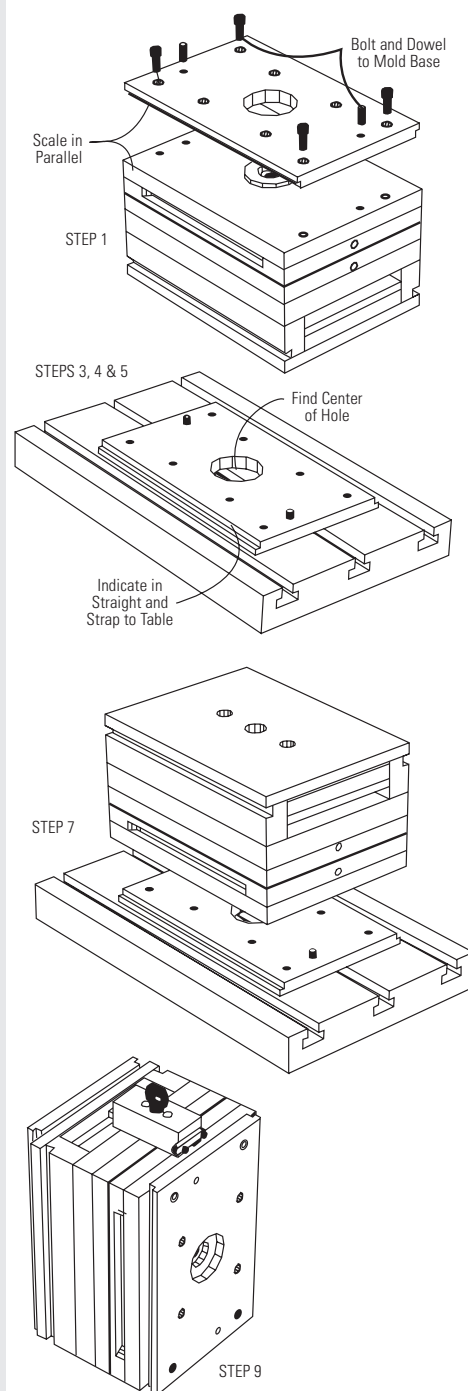

MUD[®] Mold Base Adapter System

Prior to installation

Just as in the case of the companion ear plates, the installation of a MUD[®] Quick-Change adapter frame is a simple procedure. Once installed, a single adapter frame will accommodate an unlimited number of standard mold bases.

Preparation

Before installing Master Unit Die Quick-Change adapter frame, thoroughly clean and wipe down the molding machine platen. Inspect for rust build-up and high spots. Be sure all platen surfaces are flat. Also, inspect the MUD[®] adapter frame plates for foreign matter and high spots (400 grit stone is recommended for removing high spots).

After the platens and MUD[®] adapter frame plates are cleaned and free of burrs, spray the surfaces with a high quality mold protection. This aids in

preventing build-up between platens and the MUD[®] adapter frame system.

ALWAYS check the ear plates for burrs and nicks, stoning or filing as required. Lubricate the slide areas of the ear plate and adapter frame surfaces to extend their life and to allow surfaces to slide more freely.

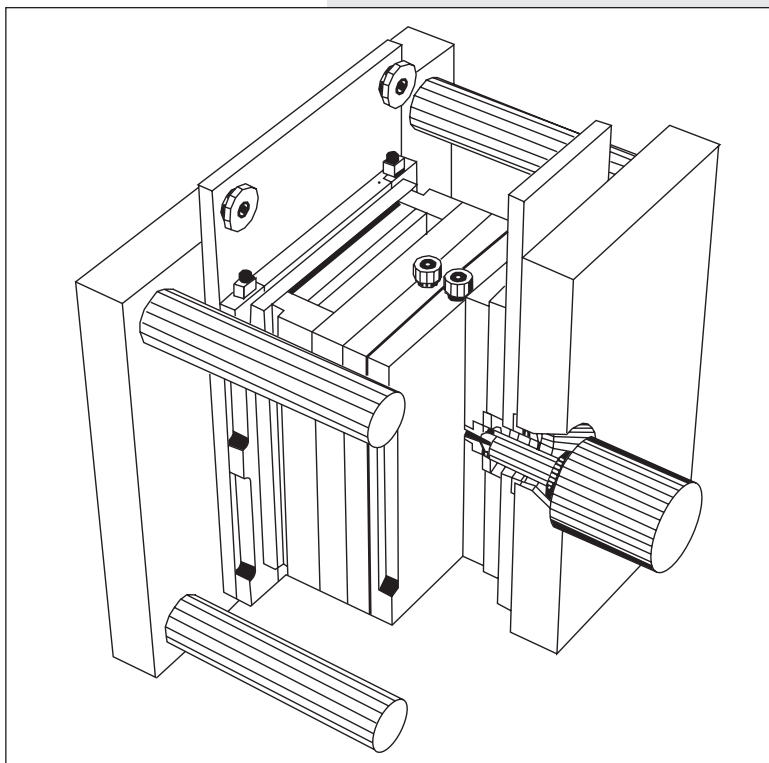

Installation instructions

Cavity Side Installation

STEP 1: Install the cavity side adapter frame in the molding machine, using clamps or bolting directly through the clamp plate of the frame. The cavity side adapter frame is aligned by the locating ring.

Rotate the adapter frame to a vertical position by using a level on the inside of the ear plate retainer rail. Be sure the mounting bolts or clamps are tight.

STEP 2: Determine that the adapter frame companion ear plates are mounted on the standard mold base as detailed in the ear plate installation instructions.

Ejector Side Installation

STEP 3: With the ear plates installed on the standard mold base, slide it into the ejector side of the adapter frame prior to installation in the molding machine. Now clamp the standard mold base in the adapter frame using the clamps on the end of the frame.

STEP 4: Measure the total shut height of the ear plates, standard mold base and adapter frame. Adjust the machine platens open an additional 1/16" to 3/16" to allow the assembly to slide between the platens and into the cavity side of the adapter frame.

STEP 5: Lift the ejector half of the adapter frame with the standard mold base installed using a MUD® balanced lifting bar. Slide the standard mold base and ejector half adapter frame into the cavity half adapter frame already installed in the machine (Step 1).

STEP 6: Close the machine to clamp the mold halves together.

STEP 7: Clamp the standard mold base adapter frame ejector half to the machine platen.

STEP 8: To remove the ear plate equipped standard mold base from the adapter frame, unclamp the four (4) ear plate hold down clamps located on the tops of the adapter frame rails. Then open the machine approximately 1/16" to 3/16".

STEP 9: If bolts are to be used through the adapter frame clamp plate, remove the standard mold base from the frame and install the bolts.

STEP 10: If the adapter frame is bolted through the clamp plate to the platen, the clamps (Step 7) can now be removed.

STEP 11: THE MUD® Quick-Change adapter frame is now ready to accept an unlimited number of standard mold bases equipped with companion ear plates.



AF Quick-Change Adapter Frame & Companion Ear Plates

MUD® Quick-Change Adapter Frame Systems for Standard Mold Bases | 12/18 AF 010

ITEM NO.	DESCRIPTION
12/18 AF 010	Adapter Frame
12/18 AEP 011	Ear Plate Set
12/18 AEP 022	Ear Plate Set w/o Mounting Holes

Ordering and installing information for adapter frame and companion ear plates can be found in the front of this section.

Extended nozzle is required to extend the additional thickness of the ear plate and back plate of the mold base adapter assembly.

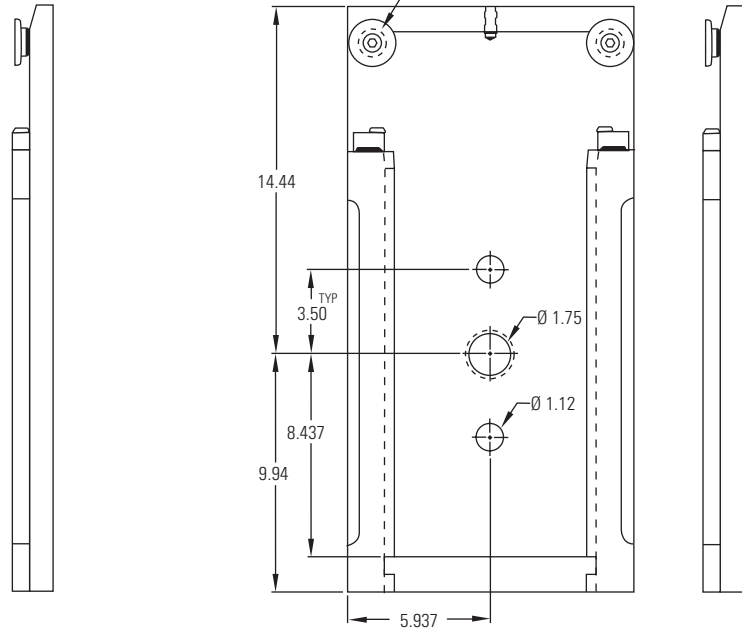
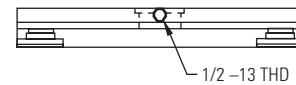
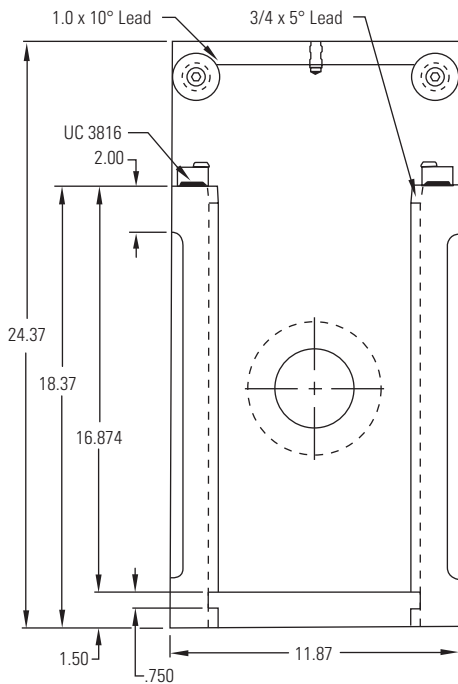
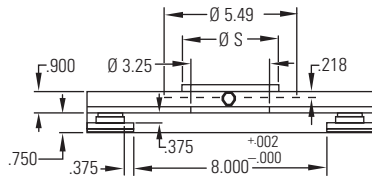
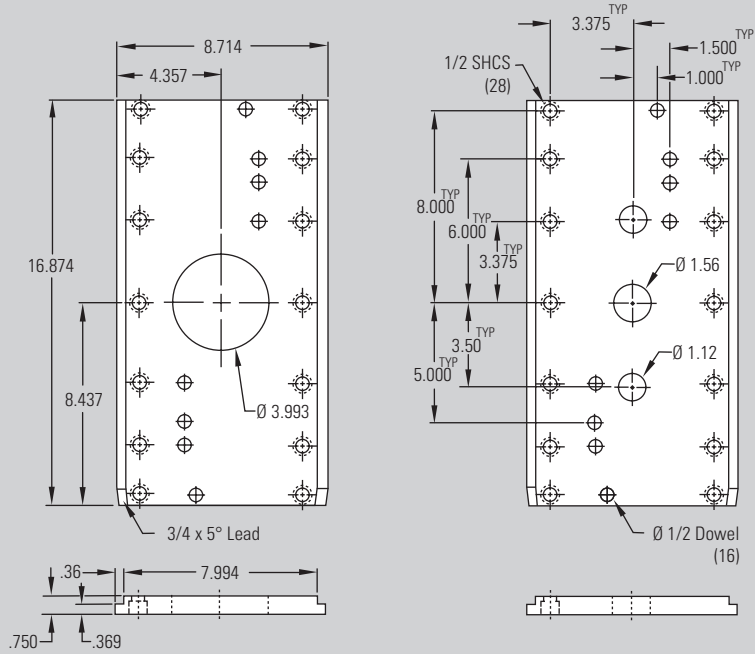

14/20
AF 010

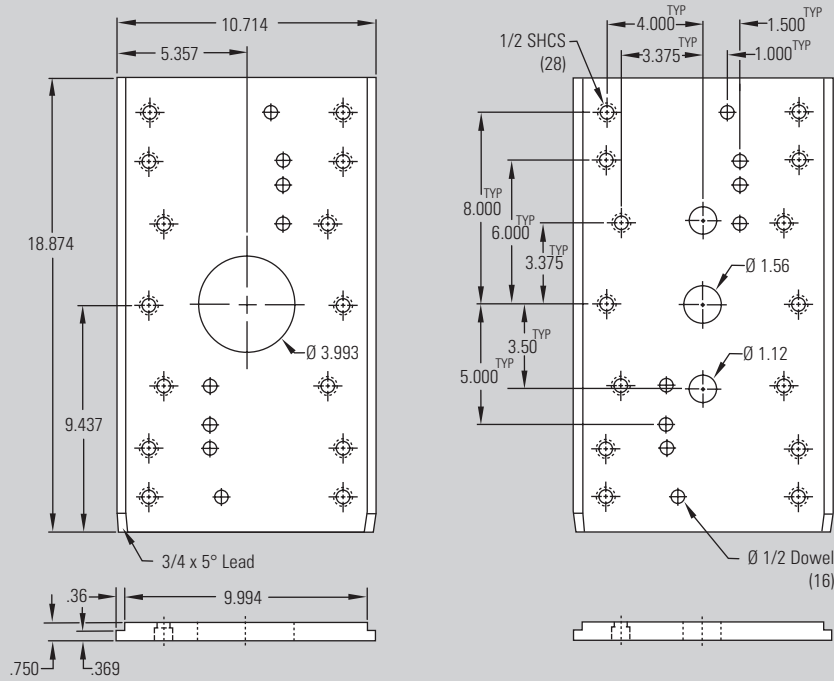

ITEM NO.	DESCRIPTION
14/20 AF 010	Adapter Frame
14/20 AEP 011	Ear Plate Set
14/20 AEP 022	Ear Plate Set w/o Mounting Holes

Ordering and installing information for adapter frame and companion ear plates can be found in the front of this section.

Extended nozzle is required to extend the additional thickness of the ear plate and back plate of the mold base adapter assembly.

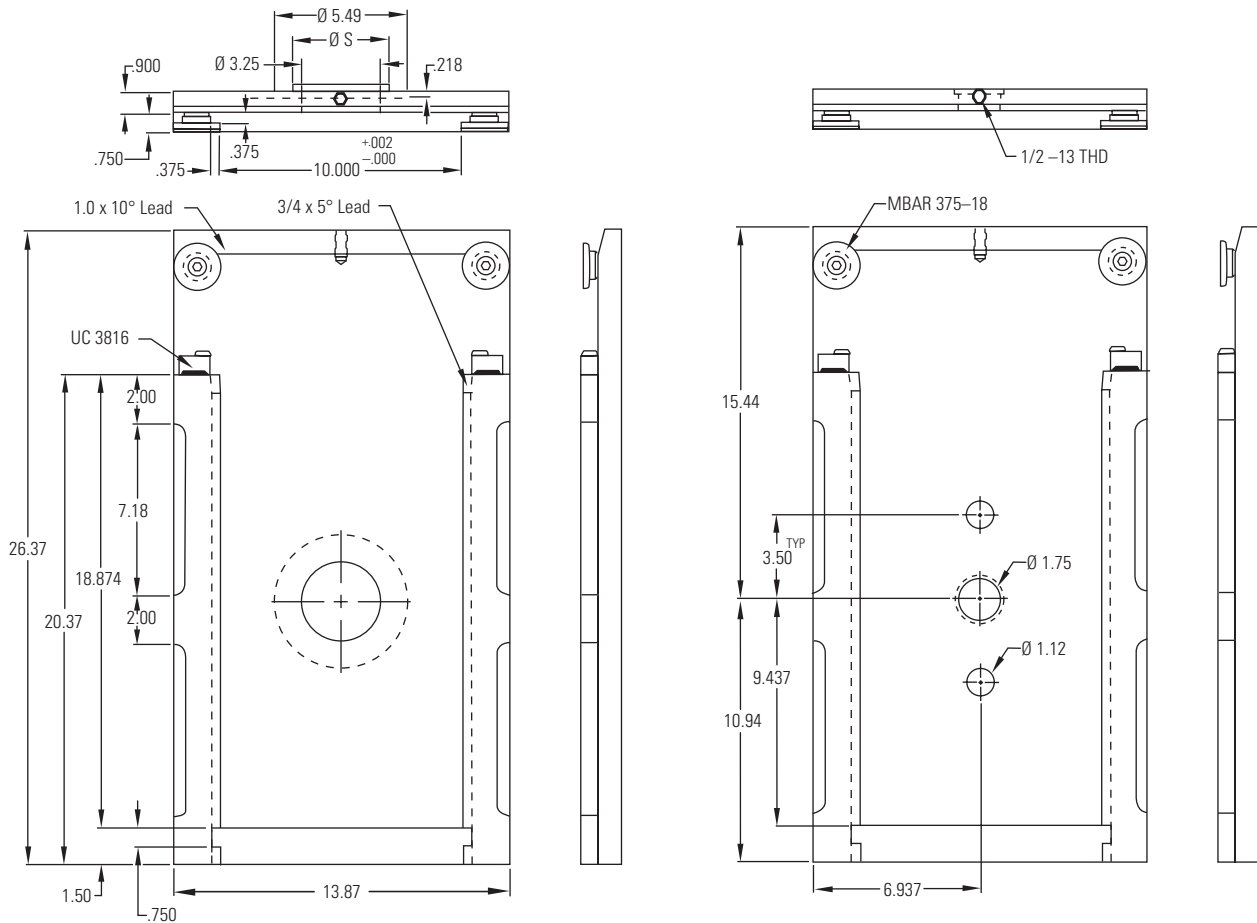



AF Quick-Change Adapter Frame & Companion Ear Plates

MUD® Quick-Change Adapter Frame Systems for Standard Mold Bases | 16/21 AF 010

ITEM NO.	DESCRIPTION
16/21 AF 010	Adapter Frame
16/21 AEP 011	Ear Plate Set
16/21 AEP 022	Ear Plate Set w/o Mounting Holes

Ordering and installing information for adapter frame and companion ear plates can be found in the front of this section.

Extended nozzle is required to extend the additional thickness of the ear plate and back plate of the mold base adapter assembly.

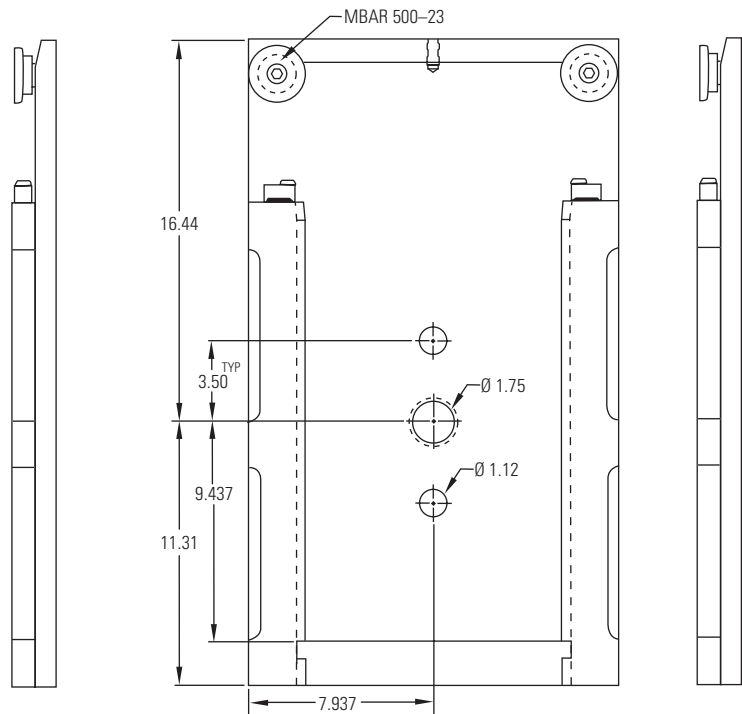
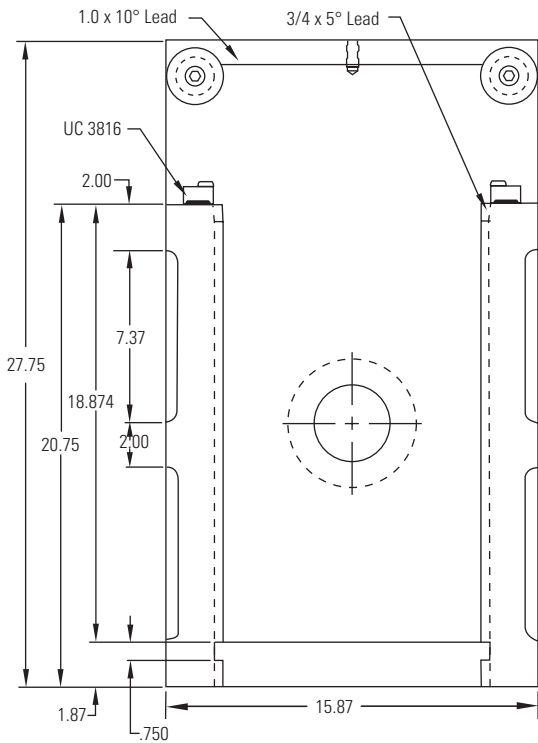
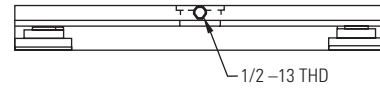
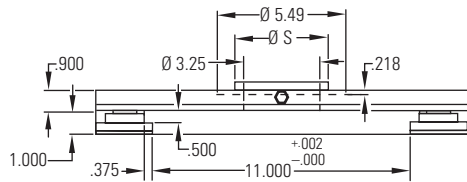
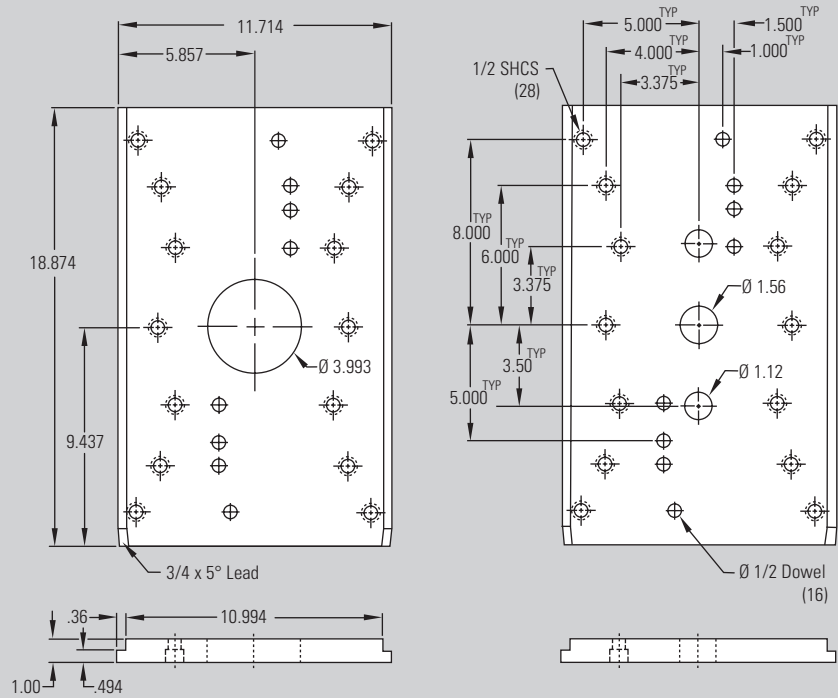

18/26
AF 010

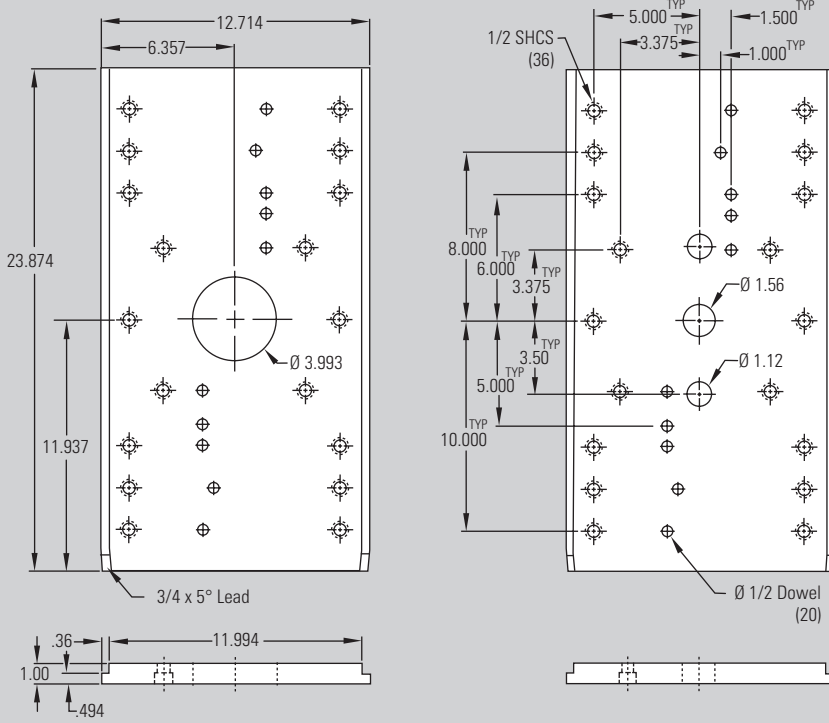

ITEM NO.	DESCRIPTION
18/26 AF 010	Adapter Frame
18/26 AEP 011	Ear Plate Set
18/26 AEP 022	Ear Plate Set w/o Mounting Holes

Ordering and installing information for adapter frame and companion ear plates can be found in the front of this section.

Extended nozzle is required to extend the additional thickness of the ear plate and back plate of the mold base adapter assembly.

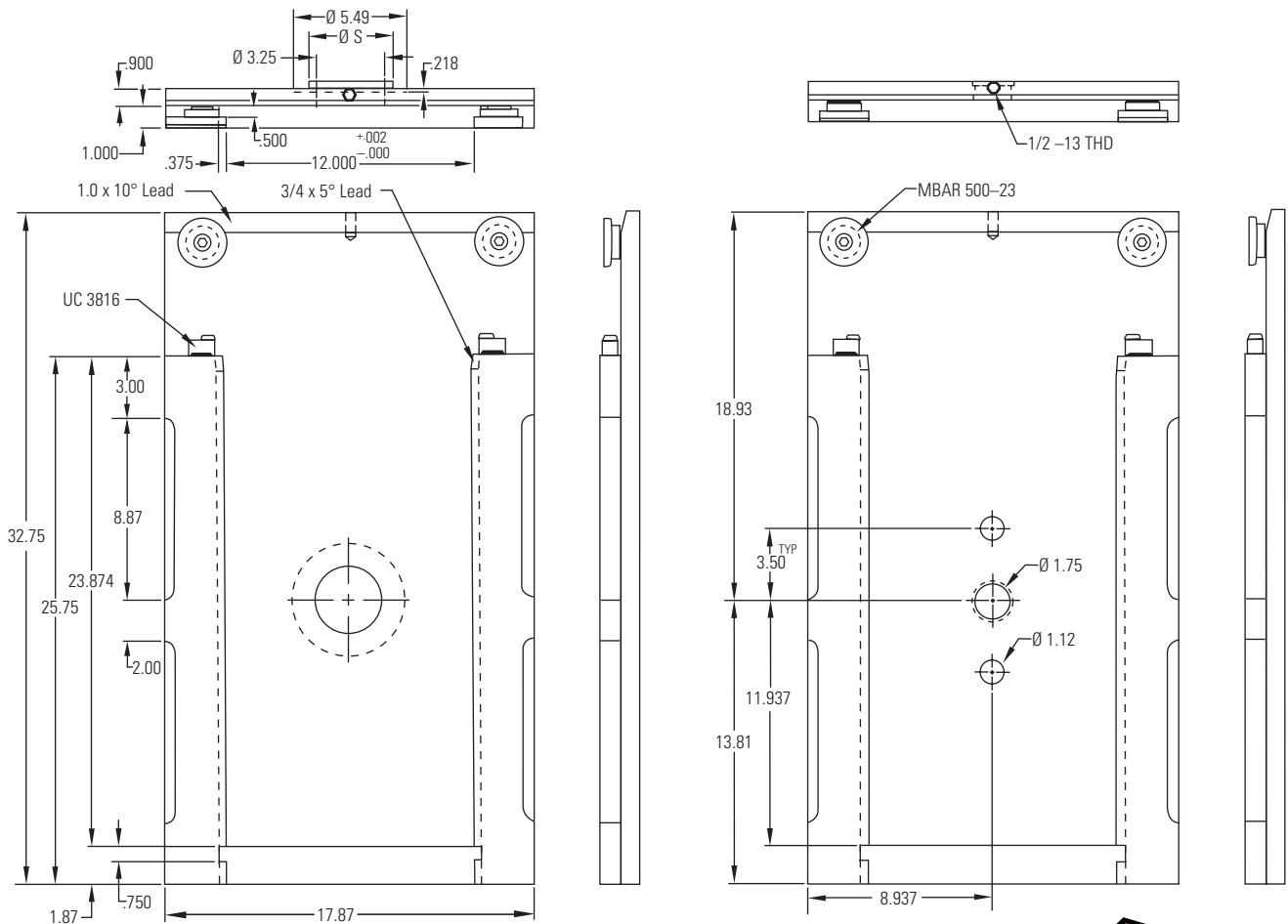

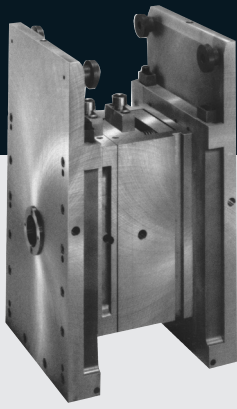

AF Quick-Change Adapter Frame & Companion Ear Plates

MUD® Quick-Change Adapter Frame Systems for Standard Mold Bases | 22/30 AF 010

ITEM NO.	DESCRIPTION
22/30 AF 010	Adapter Frame
22/30 AEP 011	Ear Plate Set
22/30 AEP 022	Ear Plate Set w/o Mounting Holes

Ordering and installing information for adapter frame and companion ear plates can be found in the front of this section.

Extended nozzle is required to extend the additional thickness of the ear plate and back plate of the mold base adapter assembly.

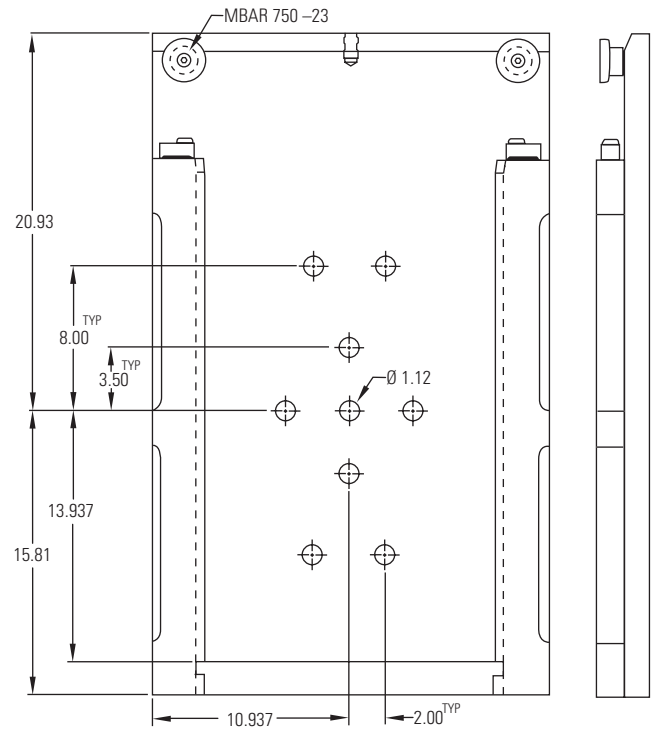
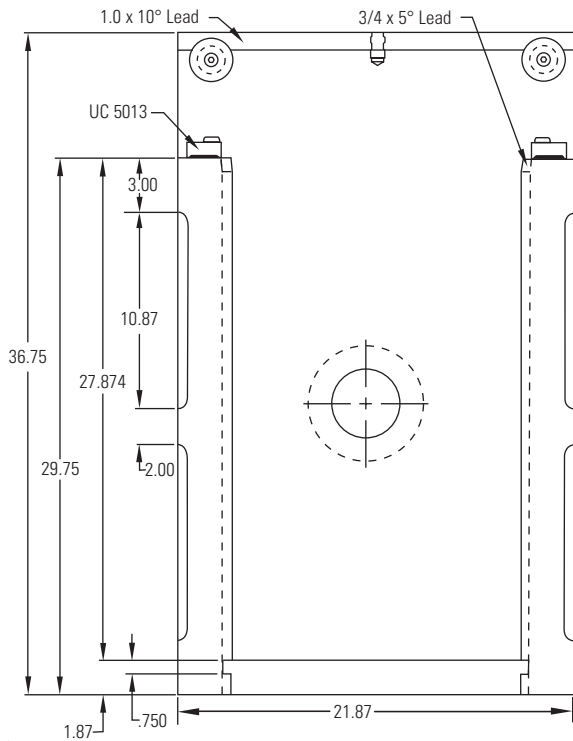
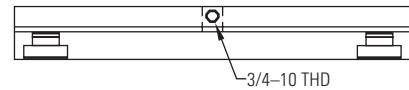
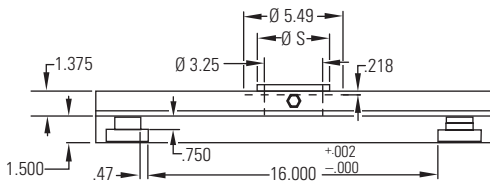
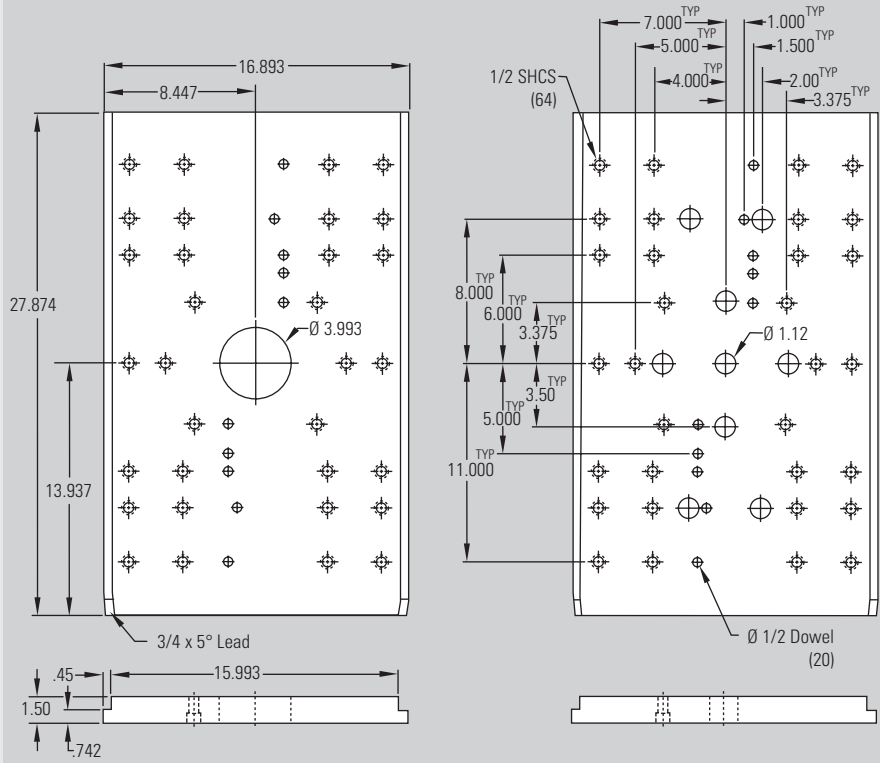

24/36
AF 010

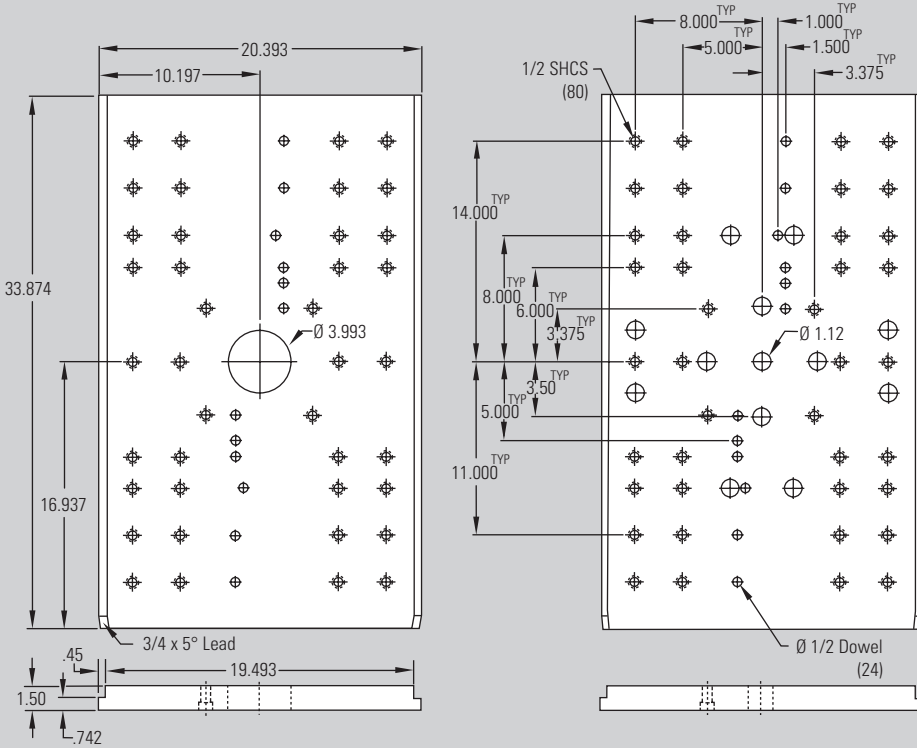

ITEM NO.	DESCRIPTION
24/36 AF 010	Adapter Frame
24/36 AEP 011	Ear Plate Set
24/36 AEP 022	Ear Plate Set w/o Mounting Holes

Ordering and installing information for adapter frame and companion ear plates can be found in the front of this section.

Extended nozzle is required to extend the additional thickness of the ear plate and back plate of the mold base adapter assembly.

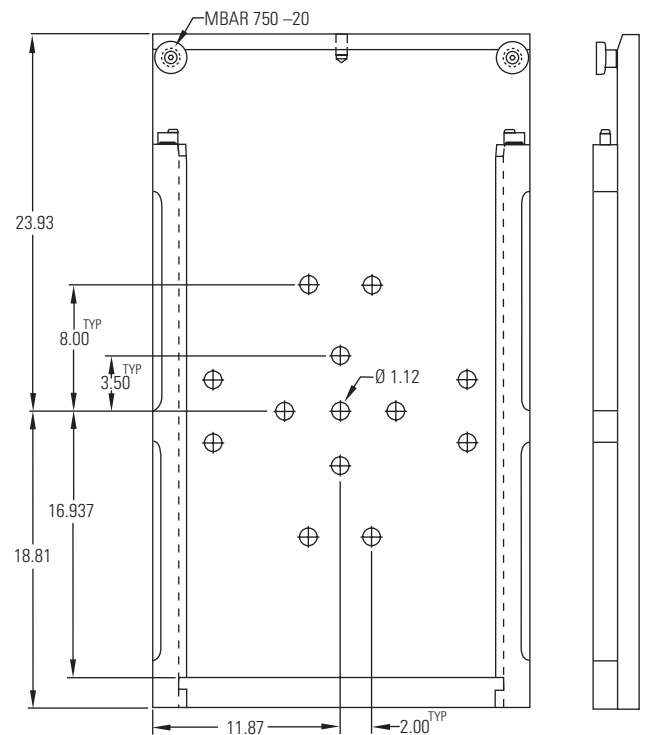
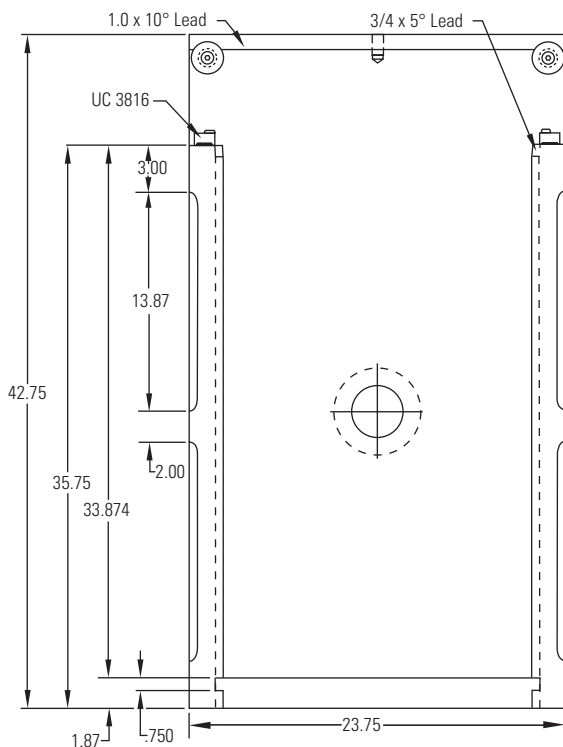
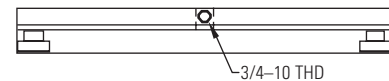
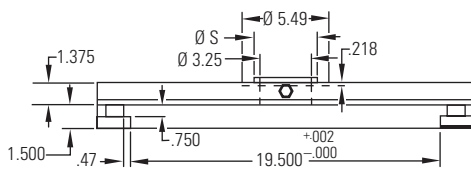

MUD® Quick-Change Adapter Frame Systems for Standard Mold Bases | 24/36 AF 010



Quick Coupler Locking KO Rod System

This knockout rod assembly is recommended for use with MUD® standard mold base adapter frame systems. It permits the molding machine's hydraulic knockout system to operate at its maximum stroke. The KO system is designed with three push points and one pull back. The A & B rods, supplied extra long for finishing to precise length, are threaded into the mold's

ejector plate flush with the back of the ear plate. The center rod locks the ejector plate to the special knockout rod installed on the machine's hydraulic knockout plates. Two rods, threaded for adjusting to proper length, are also installed on the machine's knockout plate flush with the inside surface of the adapter frame's rear clamp plate.

Quick Coupler Locking Knockout Rod Assembly and Rods

ITEM NO.	DESCRIPTION
PLKA192	Knockout rod assembly (1 required)
MLKS193	Mold knockout locking rod (1 required)
PKR194	Push rods (2 required)
MKS195	Knockout spacer rod (2 required)

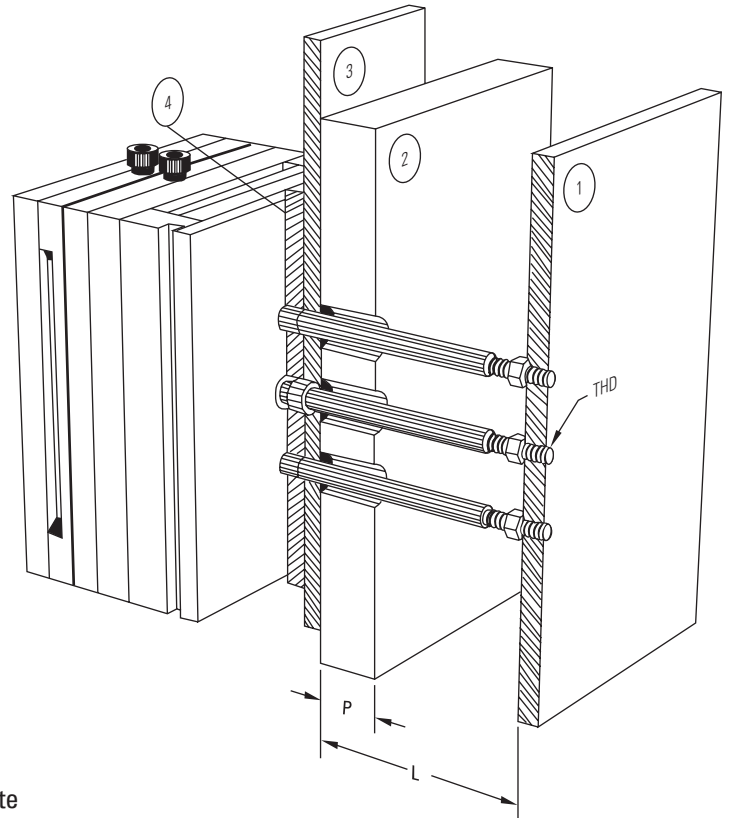
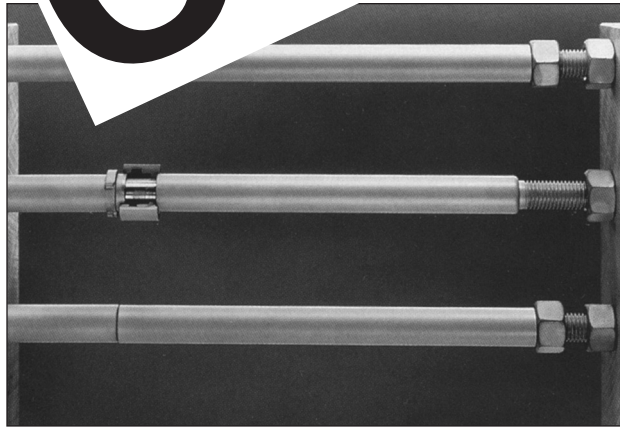
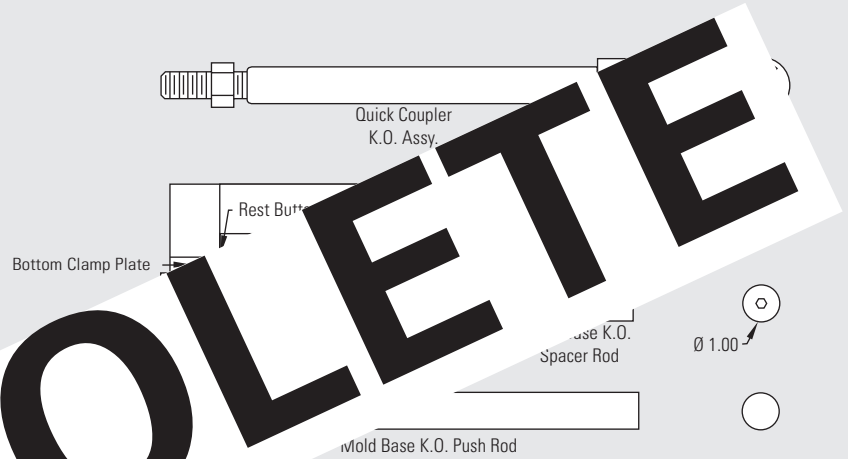

For each press supply:
THD, P & L

- ① Press ejector plate
- ② Press platen
- ③ Adapter frame clamp plate
- ④ Adapter ear plate



Balancing Lift Bars and Buttons

MUD® Balancing Lift Bars are designed with a slide-and-lock attachment for fast positioning at the balance points of insert molds and standard mold bases. These bars fit over inexpensive buttons mounted on the mold in place of eye bolts. This combination allows insert molds as well as standard mold bases to be easily lowered in and raised out of the molding machine. These bars are available in capacities to 5,140 pounds.

NOTE: Specifications subject to change without prior notice.

Lifting Bar Buttons

ITEM NO.	E	F	G	H
LB2-37	0.750	1.00	1.00	3/8-16
LB2-50	0.750	1.00	1.00	1/2-13
LB6-50	1.000	1.37	1.12	1/2-13
LB6-62	1.000	1.37	1.12	5/8-11
LB12-62	1.370	1.87	1.75	5/8-11
LB12-75	1.370	1.87	1.75	3/4-10
LB12-10	1.370	1.87	1.75	1.00-8

INSTALLING THE LIFTING BAR: Three holes (A, B and C) have been drilled and tapped in the lifting bar to accept an eye bolt (D). These holes allow positioning the eye bolt at either the center (B) or off-center (A or C) of the balancing lift bar. This position is based on the approximate weight of the mold.

The final positioning of the lifting bar is determined by sliding the lifting bar over the mold's lifting buttons until the exact balance point is established. A line is then scribed on the mold to identify this stop-point location. The A, B or C position for the eye bolt should also be noted.

Balancing Lift Bar

ITEM NO.	Max. Lift	A	B	C	D
LB-2	1720#	4.00	1.75	1.75	1/2-13
LB6	3320#	6.00	2.62	2.12	3/4-10
LB12	5140#	10.00	3.25	3.38	1 1/4-7

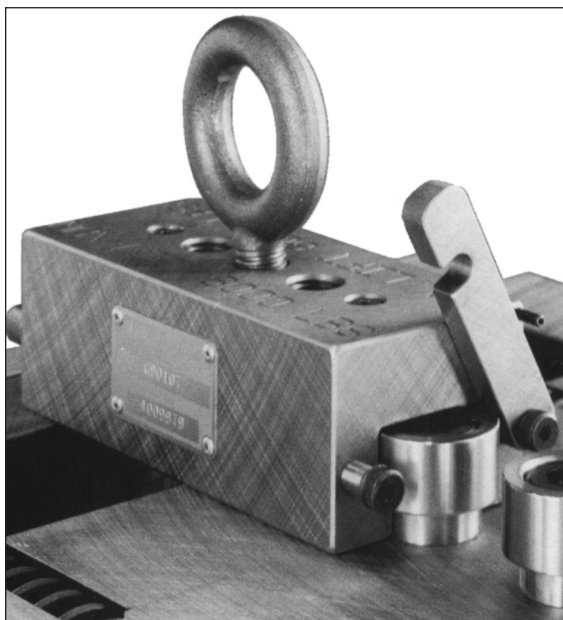

U.S. PATENT #5,033,784

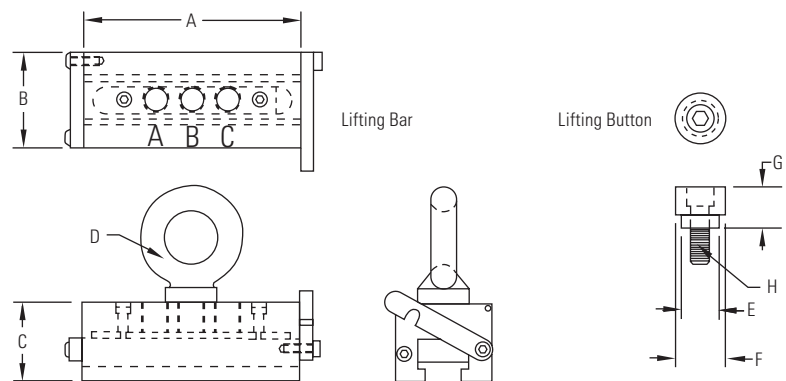

MUD® Mold Change Cart

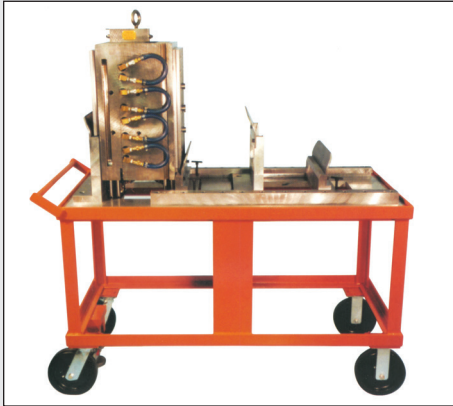

[Find My Rep](#)

The MUD® mold change cart expedites transferring molds between storage and production areas. The cart is equipped with two mold holders, one for the mold to be installed in the molding machine and one for the mold being removed.

The cart's mold retainer blocks adjust to accommodate various mold thicknesses. The cart also features adjustable rails to accommodate a wide range of standard mold bases equipped with MUD® Quick-Change adapter frame companion ear plates.

The cart includes a manifold for waterline connections. An optional temperature control unit can be installed in the cart's base to permit preconditioning the mold to the desired molding temperature prior to installing it in the molding machine.

The cart retains the mold in the position required for installation in the molding machine. This permits the use of a MUD® balanced lifting bar to decrease mold changeover time. The cart is also easily moved to align the mold with the machine platen when hoist movement is limited.

The MUD® mold change cart is designed for greater efficiency in transferring both the incoming and the outgoing molds between the storage area and the production line.

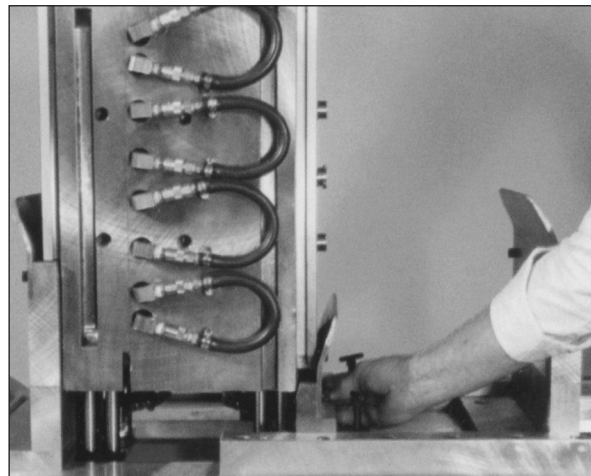

The cart features mold retainer blocks to accommodate various mold thicknesses. Adjustable rails accommodate a complete range of standard mold bases equipped with MUD® Quick-Change adapter frame companion inserts.



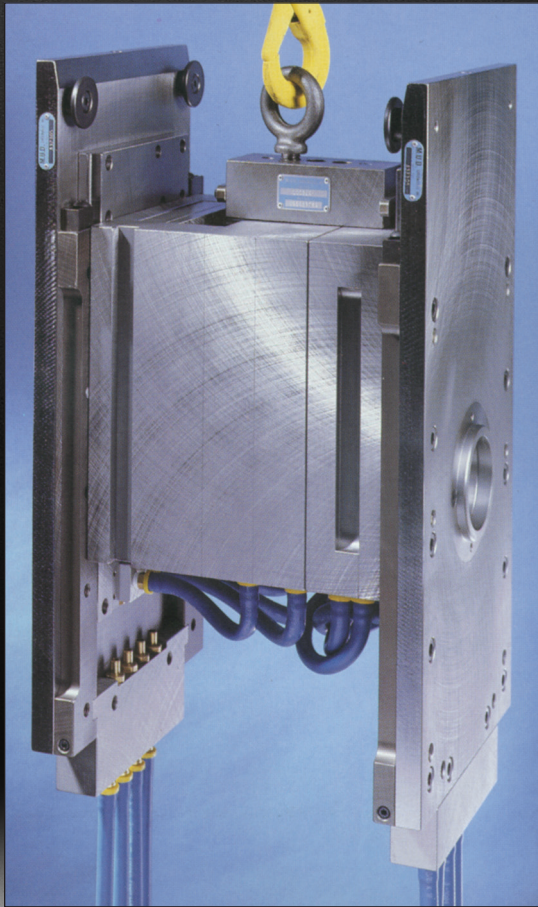

MUD® Quick-Change Mold Base Adapter Systems

with Instant-Connect Waterlines

Ordering Information

Step 1: Determine which MUD® Quick-Change Mold Base Adapter System fits your molding machine(s). Refer to the MUD® Quick-Change Adapter Systems section pages AF94 - AF101 for specifications, or call DME for personal assistance.

Step 2: Determine the number of machines that will be used with the Instant-Connect Waterline System. You will need to order a set of back section manifolds and adapter frames for each machine. The back section manifold replaces the back section supplied with the MUD® Quick-Change Mold Base Adapter Frame.

Step 3: Determine the number of molds that will be used with the Instant-Connect Waterline System. You will need to order a set of ear plates and gibs for each mold. Each set of ear plates will need to be machined to mount the waterline

manifolds. You can modify the ear plates yourself or arrange to have them machined by DME.

Step 4: Measure the lengths of the molds that will be used with the Instant-Connect Waterline System. You will need to specify a manifold for each mold length. Any mold length that extends over the face of the manifold will require the use of a universal manifold and the appropriate extended flow plate to enable installation of the mold waterlines to the ear plate manifold. Longer flow plates will also accommodate shorter mold lengths.

Step 5: Call DME. Our service representatives will help you choose the right components and place your order.

NOT RECOMMENDED for temperatures in excess of 200° F

MUD® Quick-Change Mold Base Adapter Systems

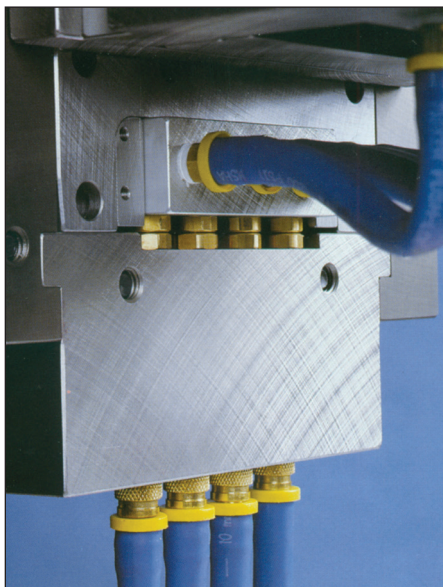

Waterlines are permanently attached to the quick change manifolds to assure accurate connections, every time.

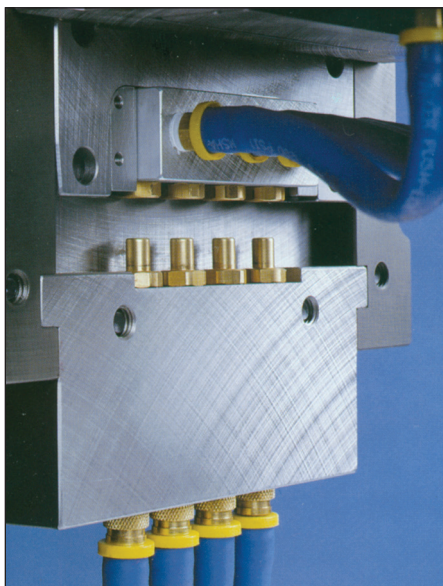

The Instant-Connect feature of the system automatically connects or disconnects your waterlines whenever you install or remove a mold.

The world's fastest Quick-Change system for standard mold bases

Five-minute mold changes from part to part? Absolutely! The Master Unit Die Quick-Change Adapter System for standard mold bases with Instant-Connect Waterlines is an engineering breakthrough that revolutionized the plastic injection molding industry.

The Quick-Change Adapter System provides molders with several important advantages:

- ▣ Reduces changeover time — dramatically!
- ▣ Easy to install — no machine modifications and only minor mold modifications
- ▣ Simple and easy to use
- ▣ Affordably priced
- ▣ Dependable — precision-built for years of trouble-free use
- ▣ Assures accurate waterline connections, every time

If you use standard mold bases, you understand the frustration of excessive downtime, complex set-ups, lost production, and inaccurate waterline connections. The MUD® Quick-Change Adapter System with Instant-Connect Waterlines changes all that.

This innovative, yet simple technology automatically connects or disconnects your waterlines whenever you install or remove a mold — a process made possible with MUD®'s integrated adapter frames and companion ear plates. MUD® Quick-Change adapter frames and companion ear plates are available in six standard sizes, each accommodating a wide range of standard mold bases.

To install the system, attach the adapter frame to your molding machine and connect the waterlines to the manifolds located in the back sections of the frame. Then, attach the ear plates to your standard mold base and connect the waterlines to the flow plate located on the end of each ear plate. Now, you're ready for a true 5-minute mold change!

The Instant-Connect Waterline System is available with manifolds for 4, 6, and 10 waterlines. The system is also available with extended flow plates to accommodate a variety of mold sizes. All manifolds and flow plates can be quickly removed for cleaning or servicing.



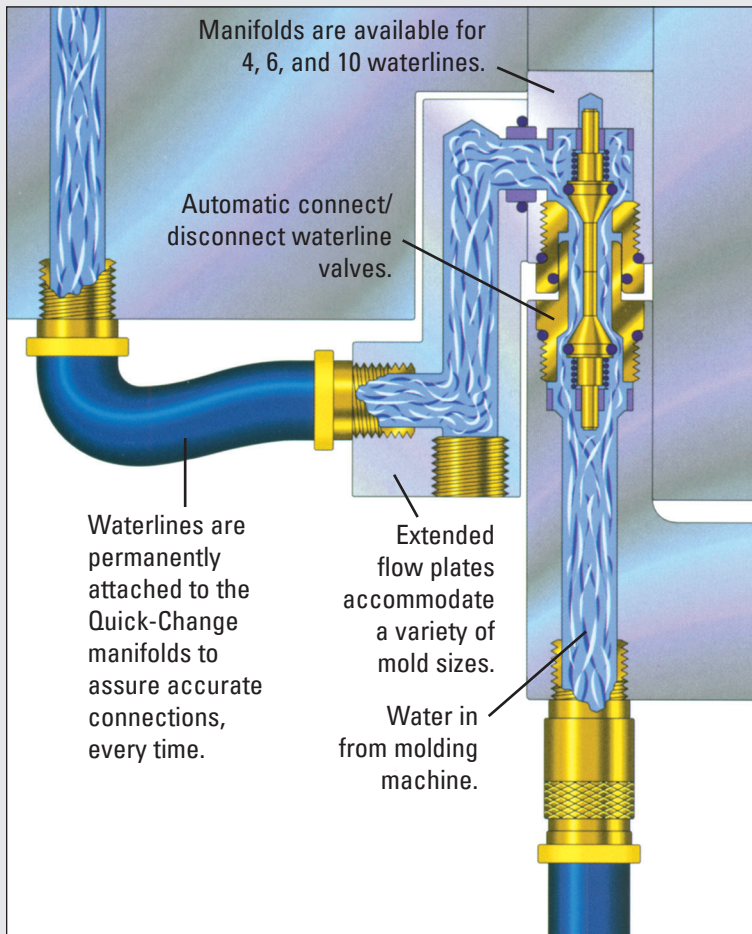

To achieve the full benefit of the Quick-Change system, the use of a MUD® mold change cart is highly recommended. This specially designed cart, with its built-in waterline manifolds, allows you to precondition the mold prior to installation. The cart is equipped to hold two molds, which makes it perfect for changing and transporting molds.

Changeovers are easy. When the new mold is properly preconditioned, remove the existing mold from the molding machine and place it on the mold change cart. When the mold is lifted, the waterlines will be auto-matically disconnected. Then, lift the new mold from the mold change cart and lower it into the adapter frame. When the mold is in place, the waterlines will be automatically connected. It's just that easy, and just that fast!

Learn more about this breakthrough technology, and how it can help you improve your productivity. Visit www.dme.net/hr-MUD to see how a video that demonstrates how MUD® quick-change systems will save time and cost within your facility.



The MUD® mold change cart, with its built-in waterline manifolds, allows you to precondition molds prior to installation. The cart is also equipped with two mold holders, which makes it perfect for changing and transporting molds.



A proven time-saver, MUD®'s exclusive Balancing Lift Bars feature slide-and-lock attachment for fast positioning at the balance point and easy in-and-out mold changes.

12/18
14/20

4-Coupler Instant-Connect Waterline System Fits 12/18 and 14/20 Mold Base Adapter Systems

Instant Connect Waterline System

Mold Base Adapter Ear Plate	Mold Base Length	L = Centerline of Ear Plate to Face of Manifold	P = Centerline of Ear Plate to Extended Flow Plate	Standard Manifold	Universal Manifold with Straight Flow Plate	Universal Manifold with Extended Flow Plate		
						3.37	5.37	7.37
12/18 AEP 011	14.00"	7.03		•	•			
	*18.75"	9.40	*7.00			•		
	*22.75"	11.40	*7.00				•	
	*26.75"	13.40	*7.00					•
14/20 AEP 011	16.00"	8.03		•	•			
	*20.75"	10.40	*8.00			•		
	*24.75"	12.40	*8.00				•	
	*28.75"	14.40	*8.00					•

* Top and bottom clamp plates of mold base must have pocket machined to accept these extended flow plates.

MUD® Quick-Change Mold Base Adapter Systems with Instant-Connect Waterlines | 12/18 14/20

ITEM NO.	DESCRIPTION
EPM-FP-374	Standard Manifold

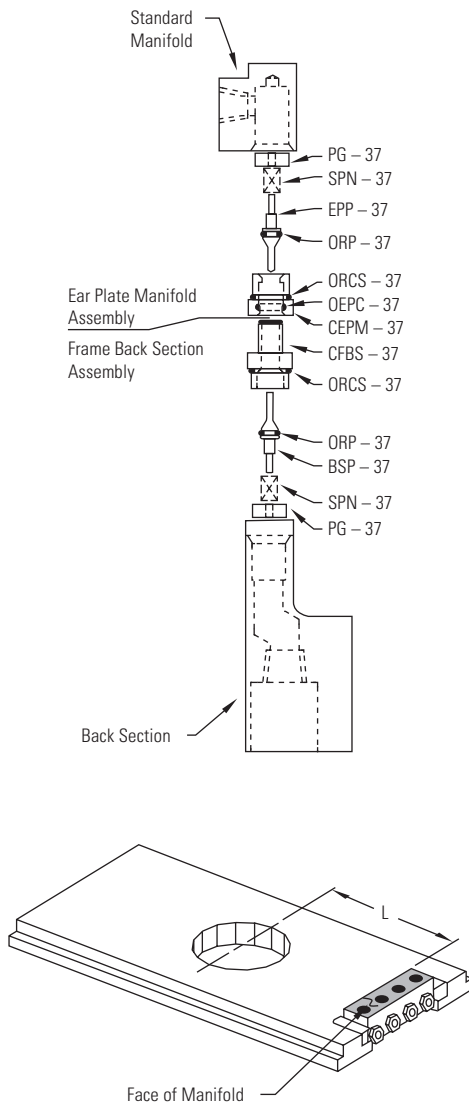

ITEM NO.	DESCRIPTION
EPM-374	Universal Manifold

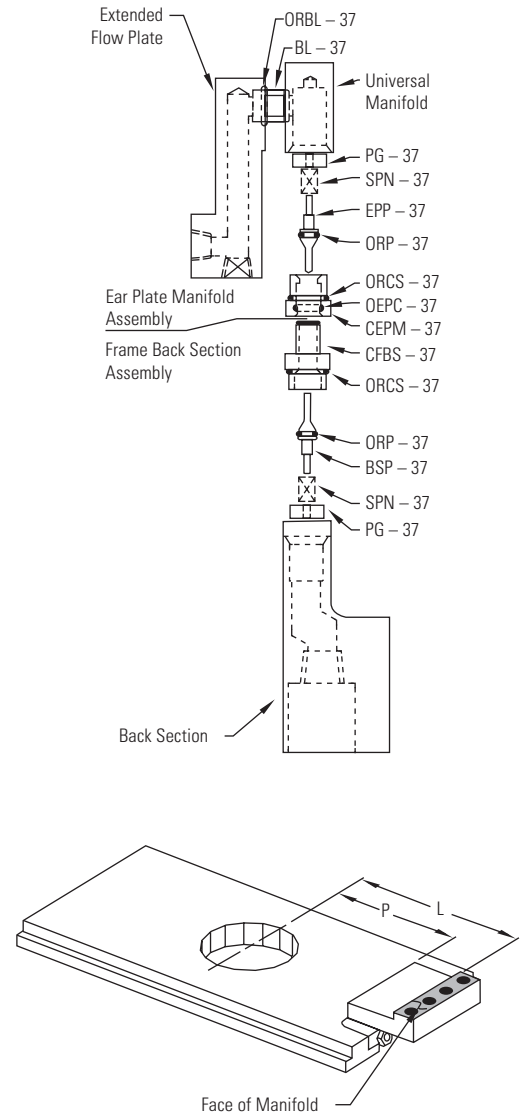

4-Coupler Instant-Connect Waterline System

For use with Standard Manifold

ITEM NO.	DESCRIPTION
EPM-FP-374	Standard Manifold

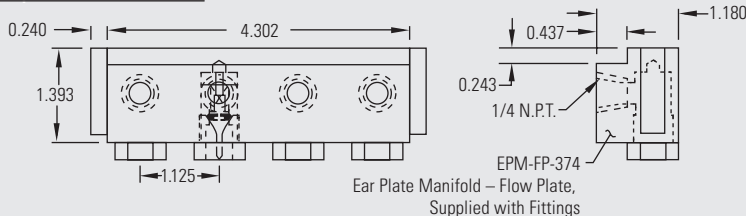

4-Coupler Instant-Connect Waterline System

For use with Universal Manifold

ITEM NO.	DESCRIPTION
EPM-374	Universal Manifold

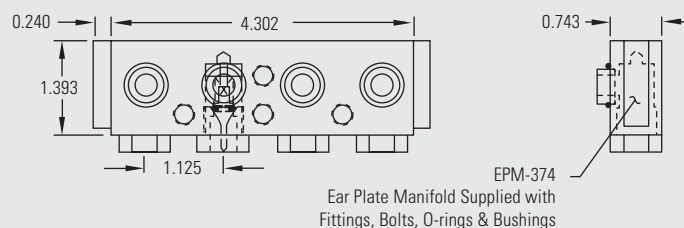

Straight Flow Plate

For use with Universal Manifold

ITEM NO.
SFP-374

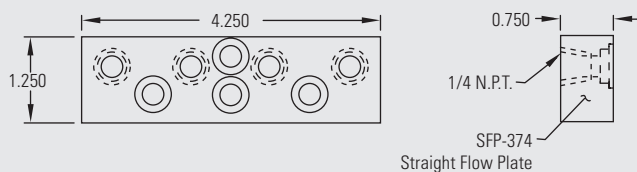

Extended Flow Plates

For use with Universal Manifold

ITEM NO.	X	Y
337-EFP-374	3.37	2.37
537-EFP-374	5.37	4.37
737-EFP-374	7.37	6.37

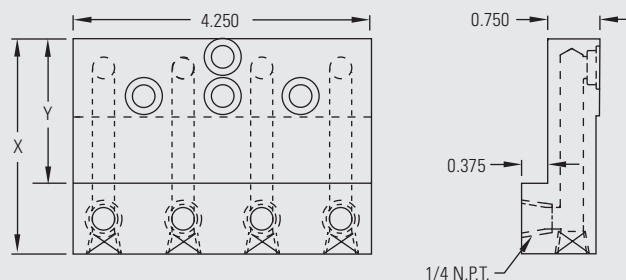

Choosing the right system for your application

The 4-Coupler Instant-Connect Waterline System is designed to fit 12/18 and 14/20 Mold Base Adapter Systems. The 4-Coupler Instant-Connect waterline manifold provides 2 waterline inlets and outlets for both the cavity and core halves of the mold. The system is uniquely designed to accommodate a wide range of standard mold base sizes. This built-in flexibility is achieved through the use of either a Standard or Universal Manifold System.

Standard Manifold System

The Standard Manifold System is designed to fit any compatible mold base that does not extend over the face of the manifold. No mold modifications are necessary to use a Standard Manifold System. To achieve the full benefits of the system, one set of Instant-Connect manifolds and ear plates should be ordered for each mold base.

Universal Manifold System

The Universal Manifold System incorporates the use of one manifold with a family of interchangeable flow plates. Each flow plate accommodates a different mold base length (see table). The universal system offers two important advantages. Firstly, it allows the use of a wide range of mold base lengths. Secondly, it permits the use of a variety of mold bases with one universal manifold and interchangeable set of flow plates. To provide room for the attachment of extended flow plates, a pocket must be machined in the top and bottom clamp plate of the mold base.

NOT RECOMMENDED for temperatures in excess of 200°F

Ordering information for the Instant-Connect Waterline System can be found on page AF 105, or call DME.

MUD® Quick-Change Mold Base Adapter Systems with Instant-Connect Waterlines | 12/18 14/20



6-Coupler Instant-Connect Waterline System Fits 16/21 and 18/26 Mold Base Adapter Systems

Instant Connect Waterline System

Mold Base Adapter Ear Plate	Mold Base Length	L = Centerline of Ear Plate to Face of Manifold	P = Centerline of Ear Plate to Extended Flow Plate	Standard Manifold	Universal Manifold with Straight Flow Plate	Universal Manifold with Extended Flow Plate		
						3.37	5.37	7.37
16/21 AEP 011	15.5"	7.78		•	•			
	*19.5"	9.84	*7.75			•		
	*23.5"	11.84	*7.75				•	
	*27.5"	13.84	*7.75					•
18/26 AEP 011	20.5"	10.28		•	•			
	*24.5"	12.34	*10.25			•		
	*28.5"	14.34	*10.25				•	
	*32.5"	16.34	*10.25					•

* Top and bottom clamp plates of mold base must have pocket machined to accept these extended flow plates.

MUD® Quick-Change Mold Base Adapter Systems with Instant-Connect Waterlines | 16/21 18/26

ITEM NO.	DESCRIPTION
EPM-FP-506	Standard Manifold

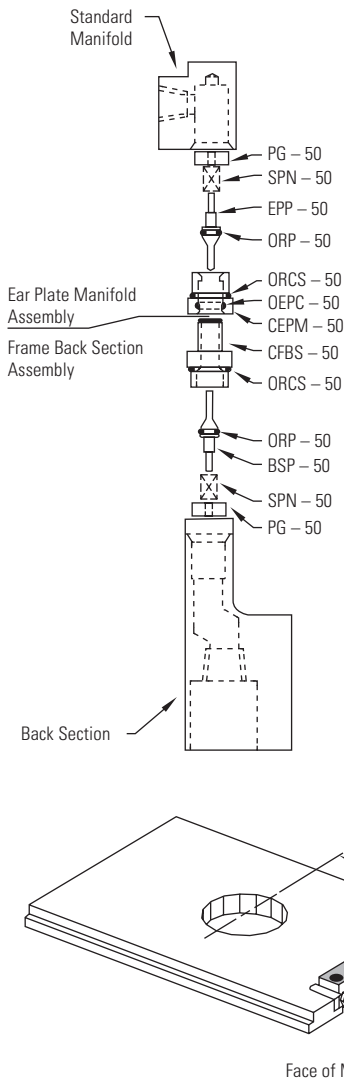

ITEM NO.	DESCRIPTION
EPM-506	Universal Manifold

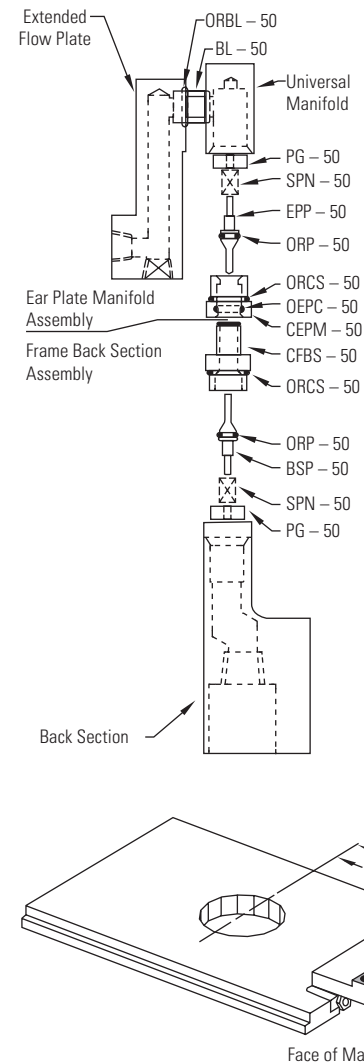

6-Coupler Instant-Connect Waterline System

For use with Standard Manifold

ITEM NO.	DESCRIPTION
EPM-FP-506	Standard Manifold

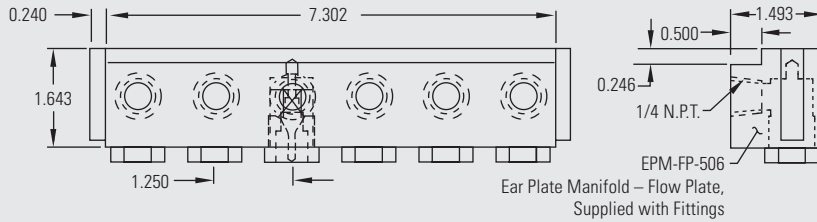

6-Coupler Instant-Connect Waterline System

For use with Universal Manifold

ITEM NO.	DESCRIPTION
EPM-506	Universal Manifold

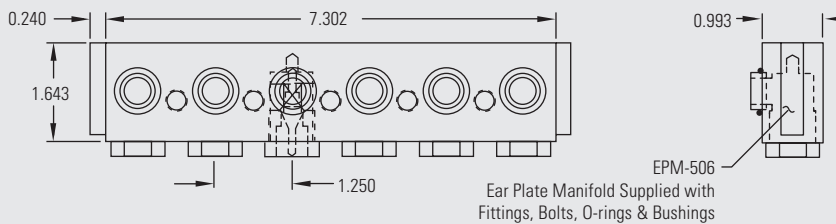

Straight Flow Plate

For use with Universal Manifold

ITEM NO.
SFP-506

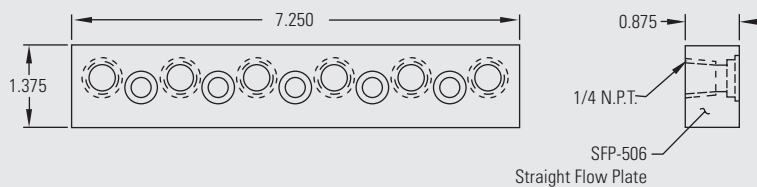

Extended Flow Plates

For use with Universal Manifold

ITEM NO.	X	Y
337-EFP-506	3.37	2.06
537-EFP-506	5.37	4.06
737-EFP-506	7.37	6.06

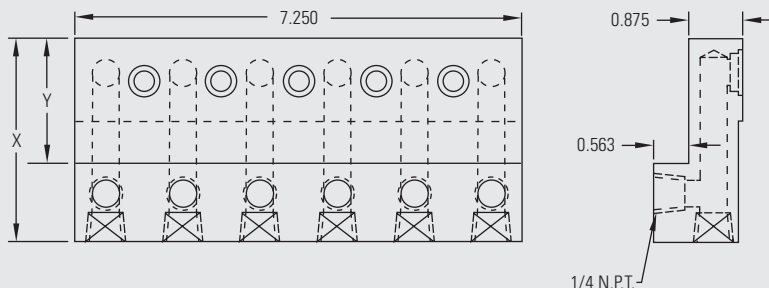

Choosing the right system for your application

The 6-Coupler Instant-Connect Waterline System is designed to fit 16/21 and 18/26 Mold Base Adapter Systems. The 6-Coupler Instant-Connect™ waterline manifold provides 3 waterline inlets and outlets for both the cavity and core halves of the mold. The system is uniquely designed to accommodate a wide range of standard mold base sizes. This built-in flexibility is achieved through the use of either a Standard or Universal Manifold System.

Standard Manifold System

The Standard Manifold System is designed to fit any compatible mold base that does not extend over the face of the manifold. No mold modifications are necessary to use a Standard Manifold System. To achieve the full benefits of the system, one set of Instant-Connect manifolds and ear plates should be ordered for each mold base.

Universal Manifold System

The Universal Manifold System incorporates the use of one manifold with a family of interchangeable flow plates. Each flow plate accommodates a different mold base length (see table). The universal system offers two important advantages. Firstly, it allows the use of a wide range of mold base lengths. Secondly, it permits the use of a variety of mold bases with one universal manifold and interchangeable set of flow plates. To provide room for the attachment of extended flow plates, a pocket must be machined in the top and bottom clamp plate of the mold base.

NOT RECOMMENDED for temperatures in excess of 200°F

Ordering information for the Instant-Connect Waterline System can be found on page AF 105, or call DME.

MUD® Quick-Change Mold Base Adapter Systems with Instant-Connect Waterlines | 16/21 18/26



10-Coupler Instant-Connect Waterline System Fits 22/30 and 24/36 Mold Base Adapter Systems

Instant Connect Waterline System

Mold Base Adapter Ear Plate	Mold Base Length	L = Centerline of Ear Plate to Face of Manifold	P = Centerline of Ear Plate to Extended Flow Plate	Standard Manifold	Universal Manifold with Straight Flow Plate	Universal Manifold with Extended Flow Plate		
						3.37	5.37	7.37
22/30 AEP 011	24.5"	12.28		•	•			
	*28.5"	14.34	*12.25			•		
	*32.5"	16.34	*12.25				•	
	*36.5"	18.34	*12.25					•
24/36 AEP 011	30.5"	15.28		•	•			
	*34.5"	17.34	*15.25			•		
	*38.5"	19.34	*15.25				•	
	*42.5"	21.34	*15.25					•

* Top and bottom clamp plates of mold base must have pocket machined to accept these extended flow plates.

MUD® Quick-Change Mold Base Adapter Systems with Instant-Connect Waterlines 22/30 24/36

ITEM NO.	DESCRIPTION
EPM-FP-5010	Standard Manifold

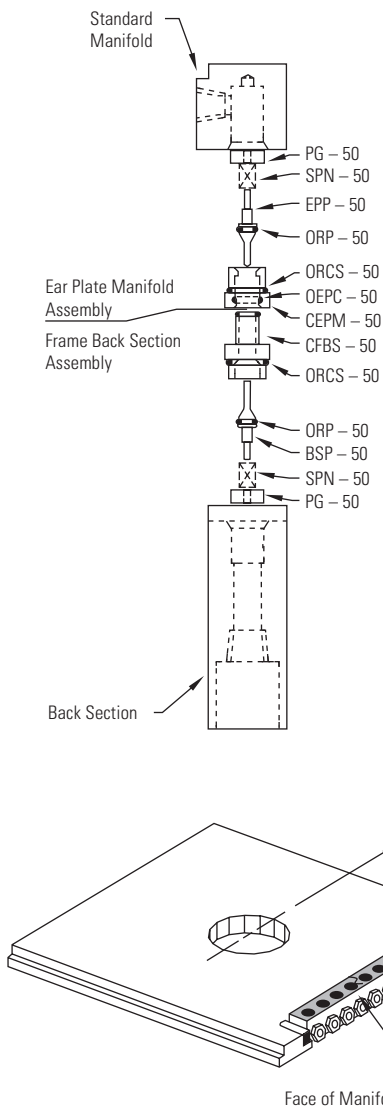

ITEM NO.	DESCRIPTION
EPM-5010	Universal Manifold

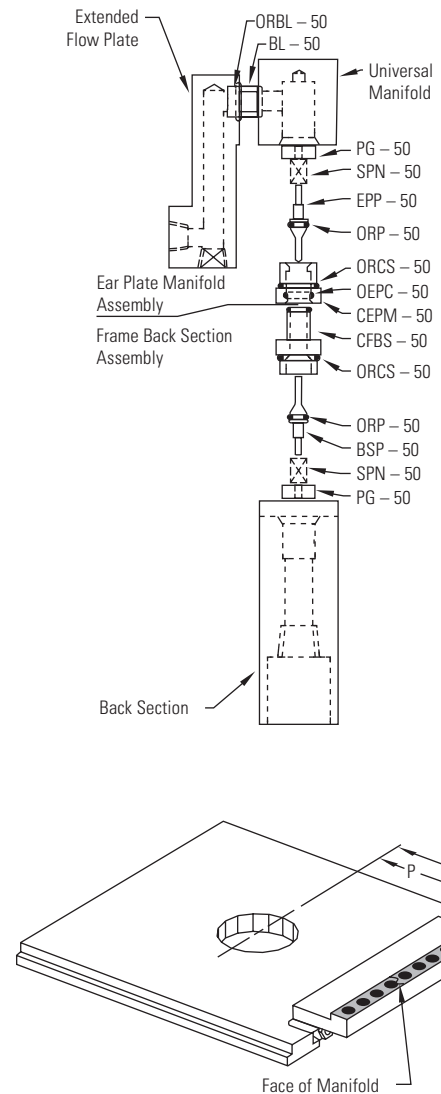

10-Coupler Instant-Connect Waterline System

For use with Standard Manifold

ITEM NO.	DESCRIPTION
EPM-FP-5010	Standard Manifold

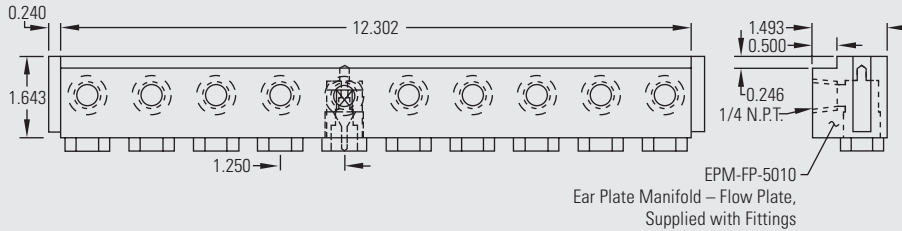

10-Coupler Instant-Connect Waterline System

For use with Universal Manifold

ITEM NO.	DESCRIPTION
EPM-5010	Universal Manifold

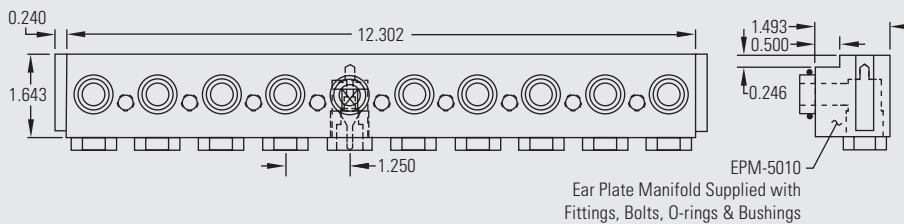

Straight Flow Plate

For use with Universal Manifold

ITEM NO.
SFP-5010

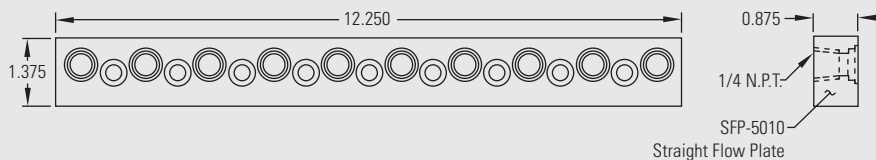

Extended Flow Plates

For use with Universal Manifold

ITEM NO.	X	Y
337-EFP-5010	3.37	2.06
537-EFP-5010	5.37	4.06
737-EFP-5010	7.37	6.06

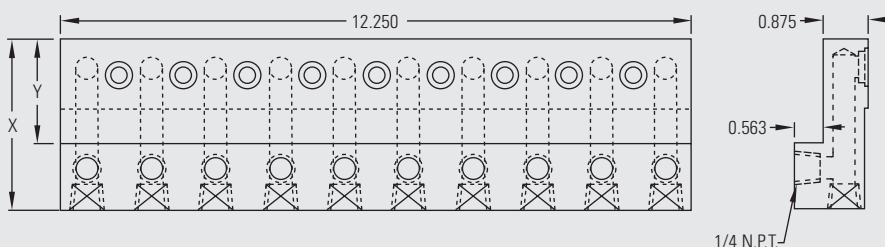

Choosing the right system for your application

The 10-Coupler Instant-Connect Waterline System is designed to fit 22/30 and 24/36 Mold Base Adapter Systems. The 10-Coupler Instant-Connect waterline manifold provides 5 waterline inlets and outlets for both the cavity and core halves of the mold. The system is uniquely designed to accommodate a wide range of standard mold base sizes. This built-in flexibility is achieved through the use of either a Standard or Universal Manifold System.

Standard Manifold System

The Standard Manifold System is designed to fit any compatible mold base that does not extend over the face of the manifold. No mold modifications are necessary to use a Standard Manifold System. To achieve the full benefits of the system, one set of Instant-Connect manifolds and ear plates should be ordered for each mold base.

Universal Manifold System

The Universal Manifold System incorporates the use of one manifold with a family of interchangeable flow plates. Each flow plate accommodates a different mold base length (see table). The universal system offers two important advantages. Firstly, it allows the use of a wide range of mold base lengths. Secondly, it permits the use of a variety of mold bases with one universal manifold and interchangeable set of flow plates. To provide room for the attachment of extended flow plates, a pocket must be machined in the top and bottom clamp plate of the mold base.

NOT RECOMMENDED for temperatures in excess of 200°F

Ordering information for the Instant-Connect Waterline System can be found on page AF 105, or call DME.

MUD® Quick-Change Mold Base Adapter Systems with Instant-Connect Waterlines | 22/30 24/36



Mold Base Adapter Back Section Manifolds

4-Coupler Back Section Manifold

12/18 AF and 14/20 AF

ITEM NO.	FRAME	X
12/18 AFBSM 104	12/18 AF	8.001
14/20 AFBSM 104	14/20 AF	10.001

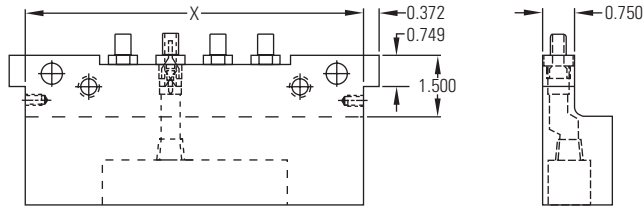

6-Coupler Back Section Manifold

16/21 AF and 18/26 AF

ITEM NO.	FRAME	X
16/21 AFBSM 106	16/21 AF	11.001
18/26 AFBSM 106	18/26 AF	12.001

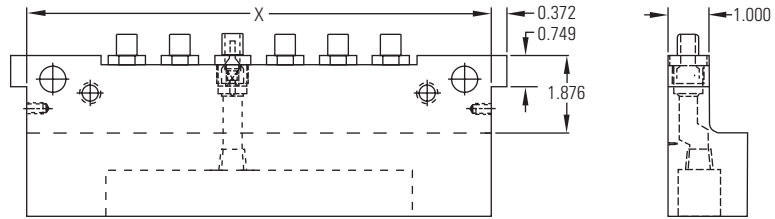

10-Coupler Back Section Manifold

22/30 AF and 24/36 AF

ITEM NO.	FRAME	X
22/30 AFBSM 110	22/30 AF	16.001
24/36 AFBSM 110	24/36 AF	19.501

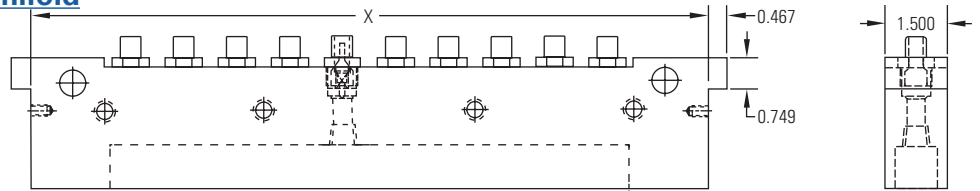

Ear Plate Machining Specifications

4-Coupler Ear Plate Pocket

12/18 AF and 14/20 AF

ITEM NO.	DESCRIPTION
EPW-374	4-Coupler Ear Plate Pocket
EPGA-374	Ear Plate Gibs

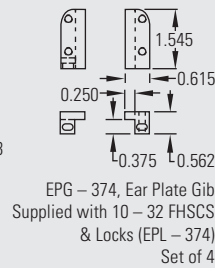
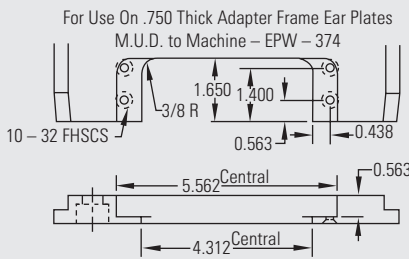

6-Coupler Ear Plate Pocket

16/21 AF and 18/26 AF

ITEM NO.	DESCRIPTION
EPW-506	6-Coupler Ear Plate Pocket
EPGA-506	Ear Plate Gibs

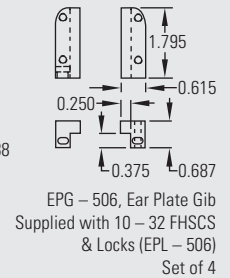
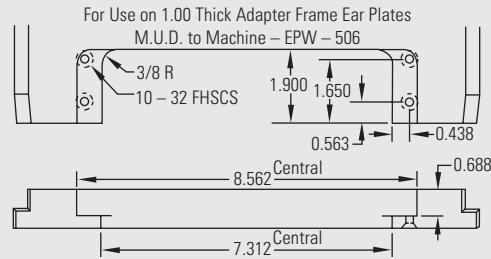

10-Coupler Ear Plate Pocket

22/30 AF and 24/36 AF

ITEM NO.	DESCRIPTION
EPW-5010	10-Coupler Ear Plate Pocket
EPGA-5010	Ear Plate Gibs

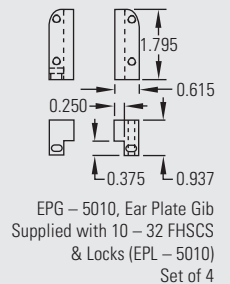
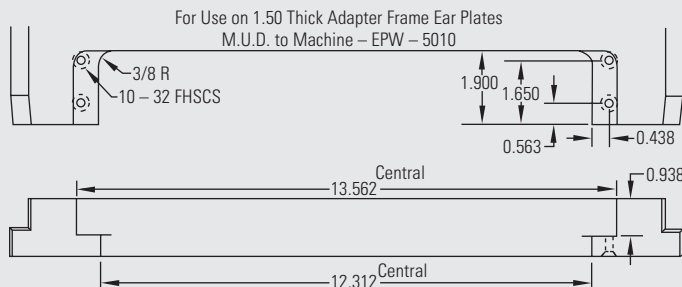

The MUD® Waterline Purge System

ITEM NO.

PSA-1000

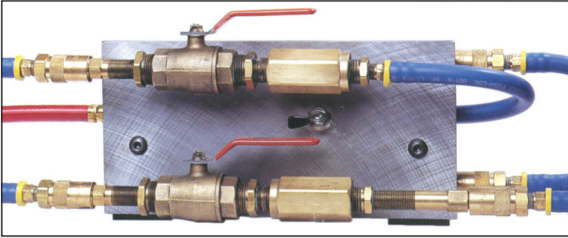

THE MUD® Waterline Purge System is specifically engineered for easy operation and virtually no maintenance.

Easy to use and sensibly priced

The MUD® Waterline Purge System is ideal for molders who prefer to purge the waterlines before storing their molds. This completely mechanical purge system is specifically engineered for easy operation and virtually no maintenance. The system is installed on the molding machine and becomes an integral part of the waterline system.

This new system allows you to purge your waterlines in 30 seconds or less!

Operation of the MUD® Waterline Purge System involves three easy steps. First, turn off the water supply with the two valves. Then, activate the air switch to inject air into the waterlines. After the cooling media has been purged from the system, the mold is ready to be changed. To begin the water flow, just return the valves to the open position. Please note: If you use an enclosed system, the purged cooling media must be drained into a holding container.

Learn more about the MUD® Waterline Purge System and the MUD® Quick-Change Adapter System with Instant-Connect Waterlines. Visit www.dme.net/hr-MUD to see how a video that demonstrates how MUD® quick-change systems will save time and cost within your facility.

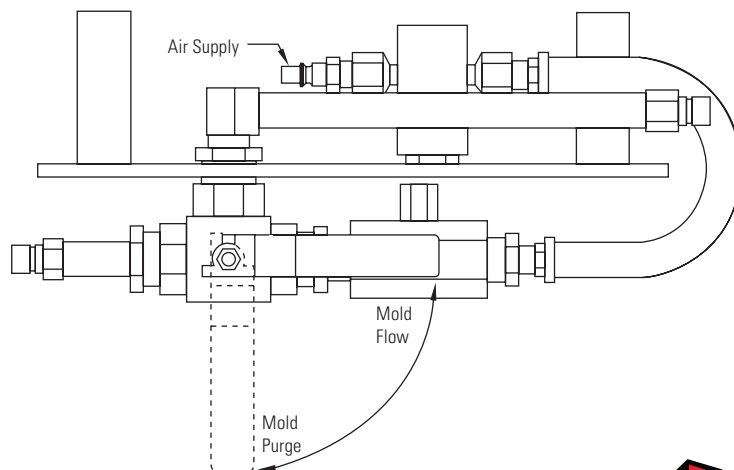
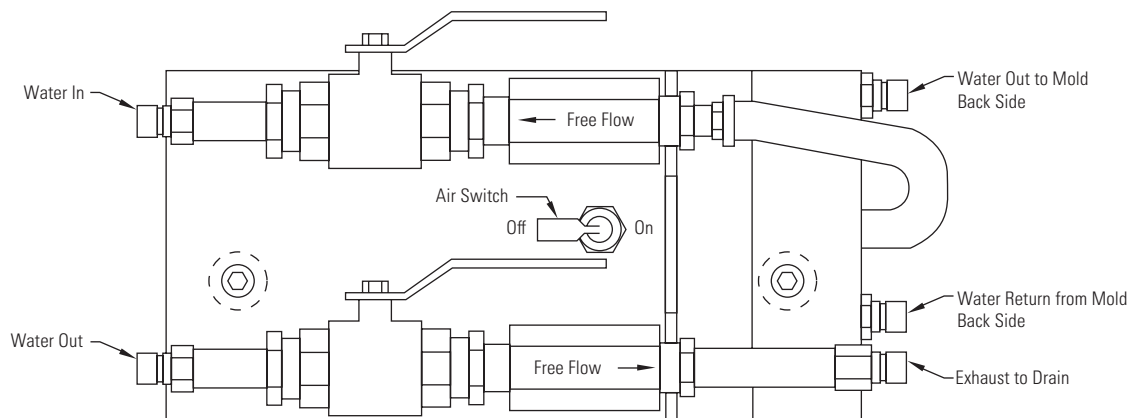

C

MUD® Quick-Change Systems from DME



Quick-Change Components
for Mold Frames & Inserts

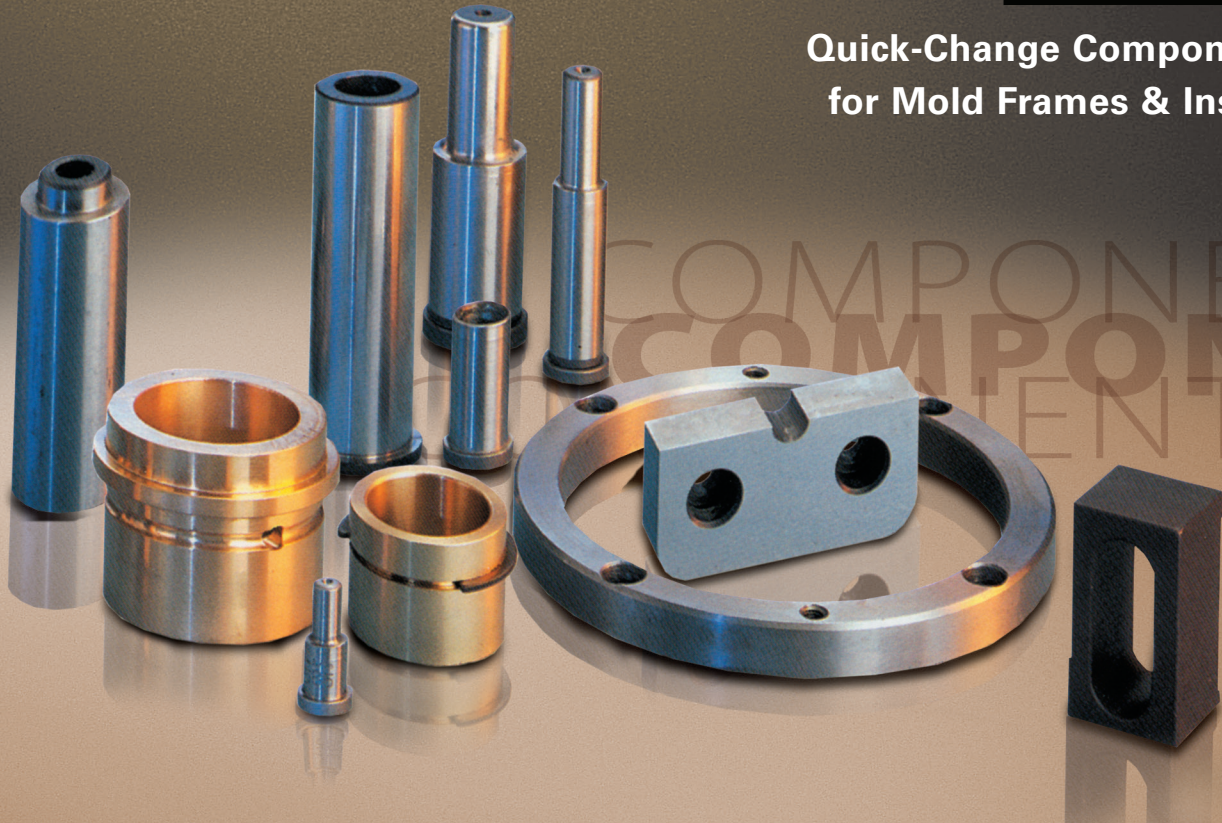

MUD® Quick-Change Components for Mold Frames and Inserts | Customize MUD® Frames & Insert

Customize MUD® frames and insert molds with a full range of components

MUD® Quick-Change frames and companion insert mold series are available with a full range of components. These components permit tailoring MUD® frames and insert molds to every injection molding machine up to 500 tons. This makes the cost-saving benefits and time-saving advantages of the Master Unit Die Concept available to virtually every mold maker and plastic molder in the industry. Many companies incorporate MUD® Quick-Change Systems as part of their lean manufacturing programs because of the proven value that MUD® systems deliver through increased uptime and reduced costs.

The components included in this brochure include all of the standard parts installed in the MUD® basic Quick-Change frames and companion insert molds. U, H and Double H frame components include sprue bushings, locating rings and guide posts. Components for T style and standard style insert molds include leader pins and bushings, ejector plates and ear plates.



U.S. 800-626-6653 ■ dme.net • store.dme.net
Canada 800-387-6600 ■ Mexico 52-442-713-5666

Quick-Change Components Frame & Insert Mold Tapered Leads

Easy alignment, faster mold changes with MUD® tapered leads

DME has an ongoing research and development program. One of the primary objectives of this program is to facilitate faster mold changes. MUD® Quick-Change systems are predicated on making these mold changes as efficient as possible. One result of this program is the 5° tapered lead.

All MUD® Quick-Change frame ear slots are now machined with these tapered leads. Seven-inch wide and larger companion insert molds are also machined with a tapered lead. The gray shading on the illustrations indicates the areas with this 5° tapered lead.

The result of this product improvement is easier alignment and faster installation of companion insert molds in MUD® Quick-Change frames.

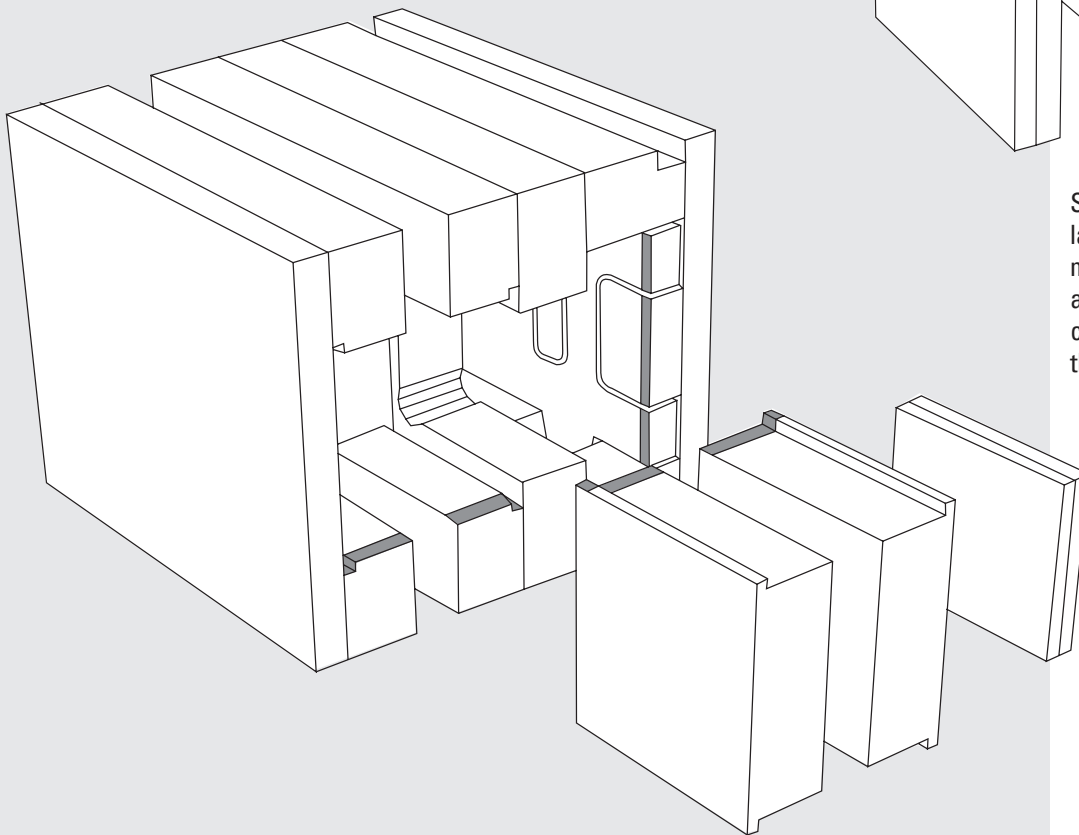

Seven-inch wide and larger companion insert molds are machined with a 5° tapered lead (indicated by gray shading on the illustrations).

Quick-Change Components Leader Pins, Bushings & Accessories

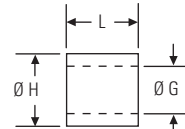
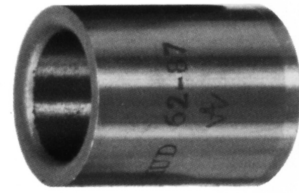
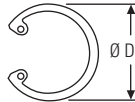
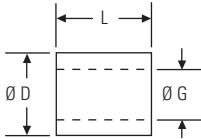

Spacers

ITEM NO.	G	D	L
SB2525	0.28	0.497	0.250
SB2550	0.28	0.497	0.500
SB3825	0.40	0.622	0.250
SB3850	0.40	0.622	0.500
SB3810	0.40	0.622	1.000
SB5025	0.53	0.863	0.250
SB5050	0.53	0.863	0.500
SB5010	0.53	0.863	1.000
SB6205	0.65	0.995	0.500
SB6210	0.65	0.995	1.000
SB6215	0.65	0.995	1.500

Snap Rings*

ITEM NO.	PIN	D
MUD®5000-50	Ø 0.250	0.55
MUD®5000-62	Ø 0.375	0.69
MUD®5000-86	Ø 0.500	0.96
MUD®5000-100	Ø 0.625	1.11

*10 per package

Straight Bushings*

ITEM NO.	G	H	L
MUD®25-37	0.252	0.376	0.50
MUD®37-50	0.377	0.501	0.50
MUD®50-75	0.502	0.751	0.75
MUD®62-87	0.627	0.876	1.00
MUD®75-87	0.751	1.125	0.87
MUD®75-13	0.751	1.125	1.38

*Replacement bushings for certain previously constructed insert



Shoulder Leader Pin and Bushing Assembly (see p. C)

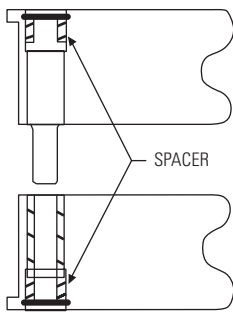

Shoulder leader pin and bushing with spacer

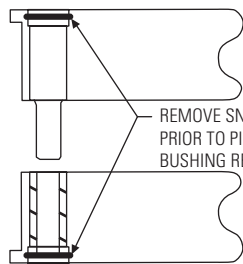

Shoulder leader pin and bushing without spacer

REMOVE SNAP RING PRIOR TO PIN AND BUSHING REMOVAL

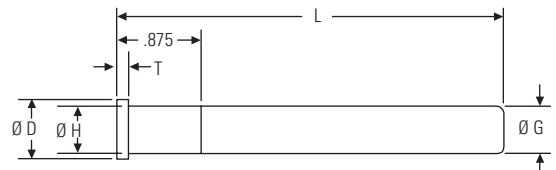

Straight Leader Pins**

ITEM NO.	G	H	D	T	L
SP3-4000	0.374	0.3755	0.610	0.125	4.0
SP5-4000	0.499	0.5005	0.610	0.125	4.0
SP6-4000	0.624	0.6255	0.853	0.187	4.0
SP3-6000	0.374	0.3755	0.610	0.125	6.0
SP5-6000	0.499	0.5005	0.610	0.125	6.0
SP6-6000	0.624	0.6255	0.853	0.187	6.0

**Designed for stripper plate and three-plate

MUD® Quick-Change Components for Mold Frames & Inserts

Leader Pins, Bushings & Accessories



Quick-Change Components Sprue Bushings

Sprue Bushings

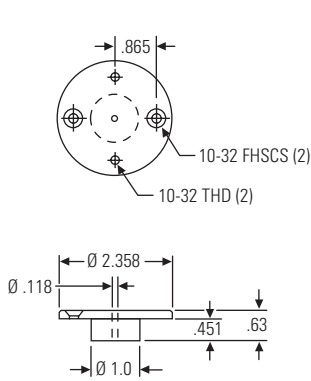
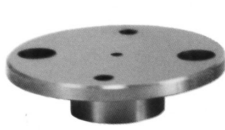

ITEM NO.
SB2310-63-001

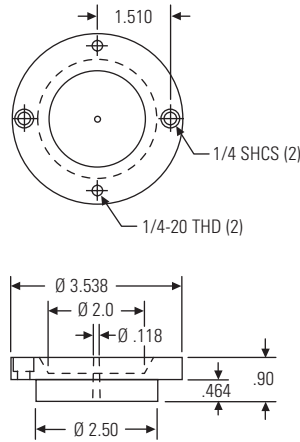

ITEM NO.
SB3525-90-001

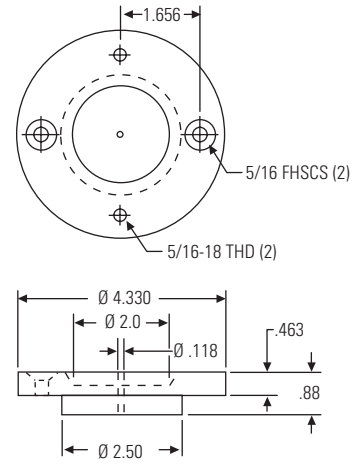
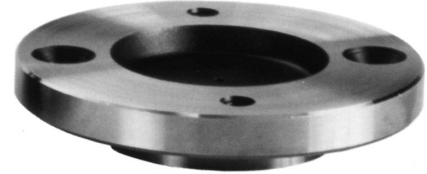

ITEM NO.
SB4325-88-001

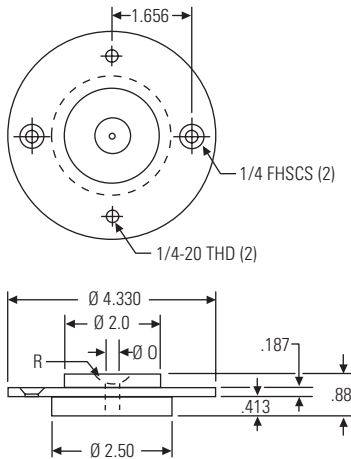

ITEM NO.
SB2025-88

SB2025-88 sprue bushing supplied flat with 1/8" orifice or with 1/2" or 3/4" radius with 1/8", 5/32", 7/32" or 9/32" orifice.

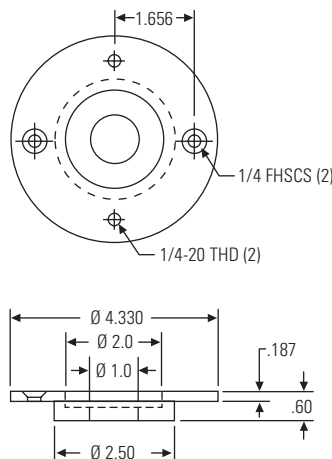

ITEM NO.
SB4325-60

SB4325-60 adapter ring is designed for frames having a 2-1/2" sprue opening to accept SB2010-92 sprue bushing.

Ordering Information for Sprue Bushings

- Item number and description
- Orifice taper is 1° 11" per side



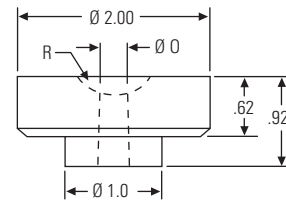
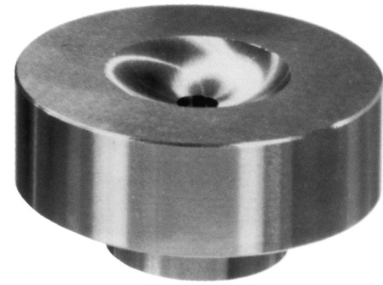

ITEM NO.
SB2010-92

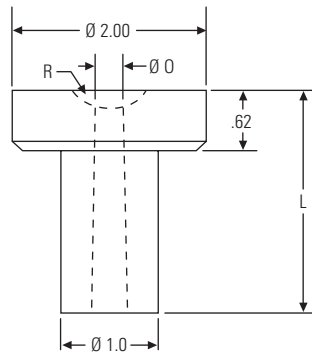
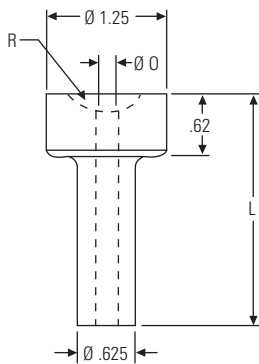

Sprue Bushings

ITEM NO.	L
SB1262-19	1.90
SB1262-29	2.90

H Frame Sprue Bushings

ITEM NO.	L
SB2010-18	1.81
SB2010-23	2.31
SB2010-28	2.81
SB2010-33	3.31
SB2010-38	3.81
SB2010-43	4.31

Ordering Information for Sprue Bushings

- Item number and description
- Specify "O" (orifice) available in 5/32", 7/32" and 9/32"
- Specify "R" (radius) available in 1/2" and 3/4"
- Taper is 1/2" per foot (included angle)



Quick-Change Components Top Locating Rings

Top Locating Rings

MUD® Quick-Change Components for Mold Frames & Inserts | Top Locating Rings

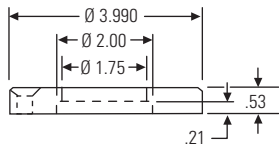
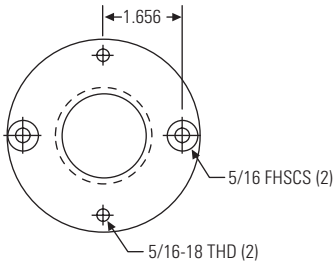

ITEM NO.

LR191R

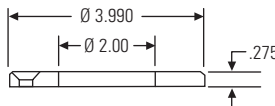
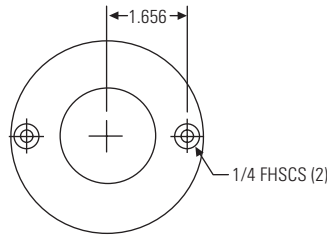

ITEM NO.

LR171

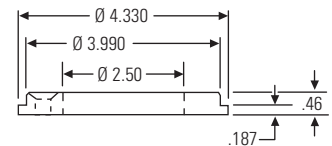
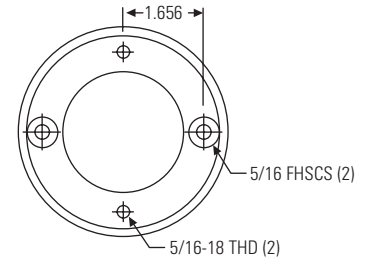

ITEM NO.

LR153

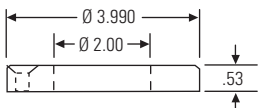
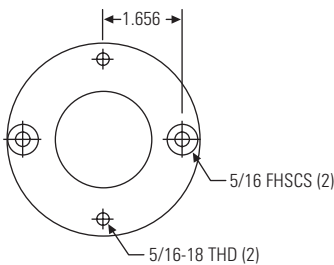

ITEM NO.

LR191

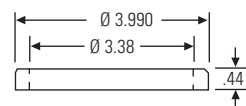
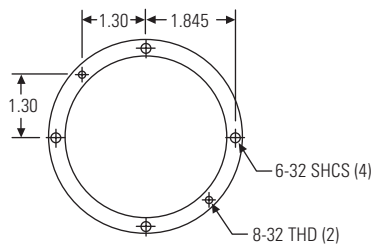

ITEM NO.

LR181

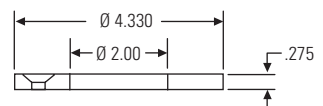
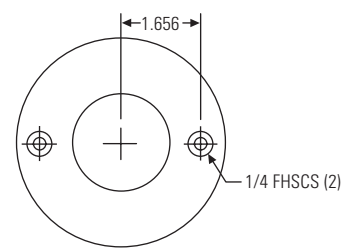

ITEM NO.

LR173



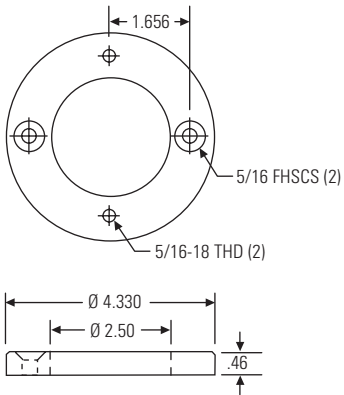

ITEM NO.
LR163

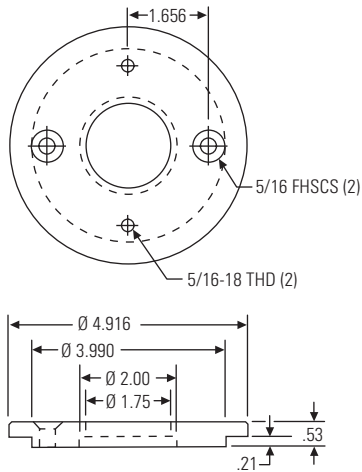

ITEM NO.
LR192R

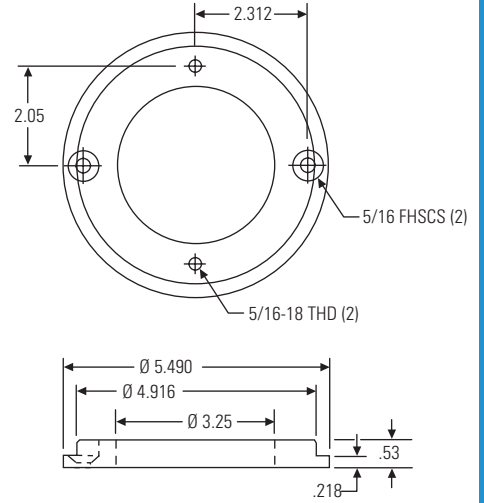

ITEM NO.
LR202

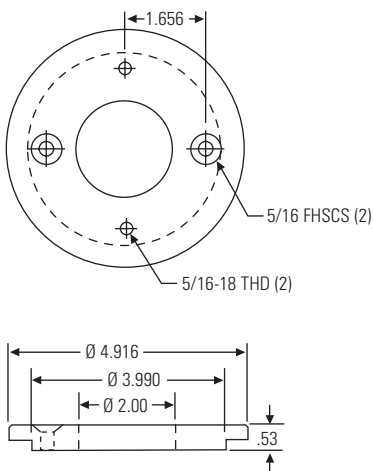

ITEM NO.
LR192

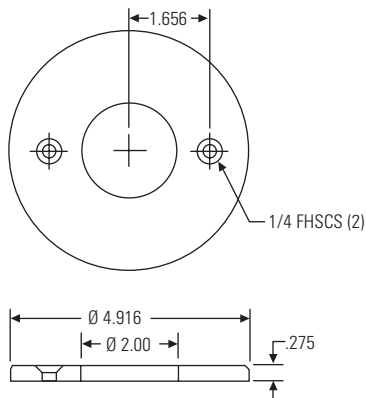

ITEM NO.
LR174

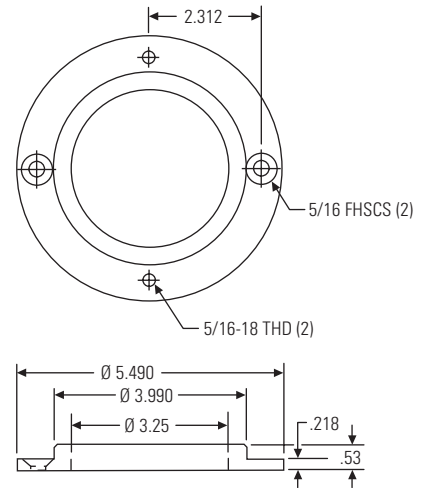

ITEM NO.
LR201

Quick-Change Components Bottom Locating Rings

Bottom Locating Rings

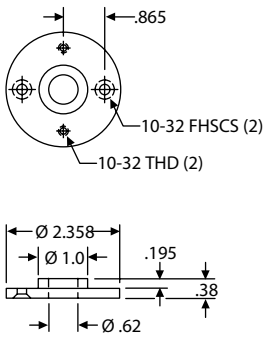
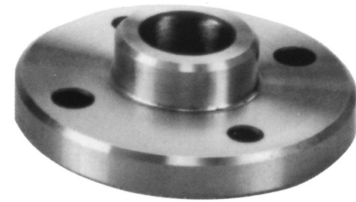

ITEM NO.	DESCRIPTION
LR135	Locating Ring
EX37M10	Knockout Rod CC

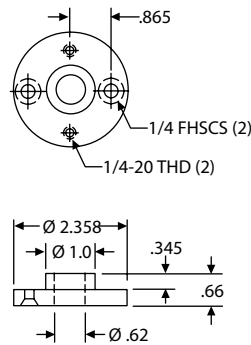

ITEM NO.	DESCRIPTION
LR172	Locating Ring
EX37M10	Knockout Rod CC

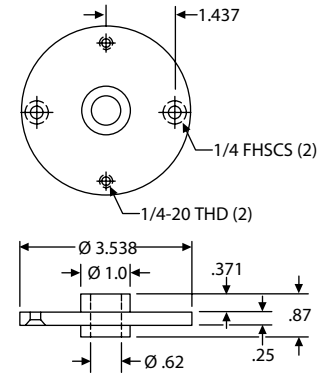

ITEM NO.	DESCRIPTION
LR142	Locating Ring
EX37M10	Knockout Rod CC

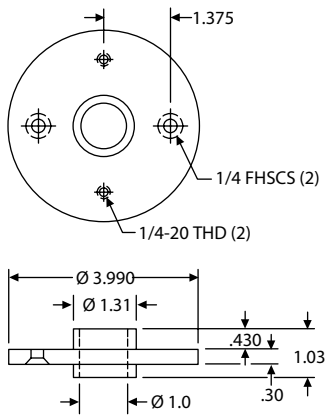

ITEM NO.	DESCRIPTION
LR182	Locating Ring
EX47M10	Knockout Rod CC

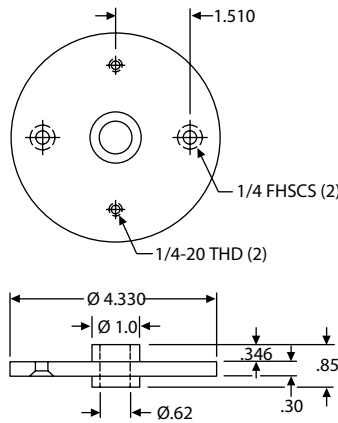

ITEM NO.	DESCRIPTION
LR165	Locating Ring
EX37M10	Knockout Rod CC

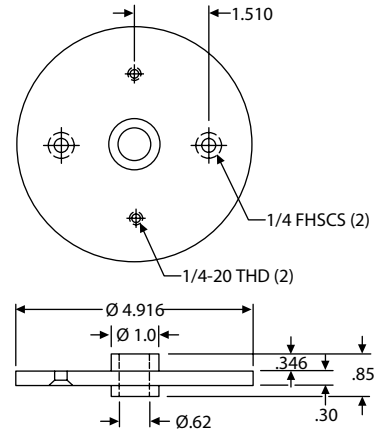

ITEM NO.	DESCRIPTION
LR166	Locating Ring
EX37M10	Knockout Rod CC

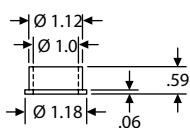

ITEM NO.
LR168

Adapter bushing for 08/09UF and 84/90UF bottom locating rings.

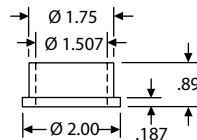

ITEM NO.
KOB-150

Bushing for standard mold base adapter KO rod (bronze).



Quick-Change Components Mold Clamps

FOR PLASTIC MOLDS

Forged from high-tensile steel and carbonitride hardened. The design features a hardened no-turn washer and a shape and range of sizes that permit universal application for any mold.

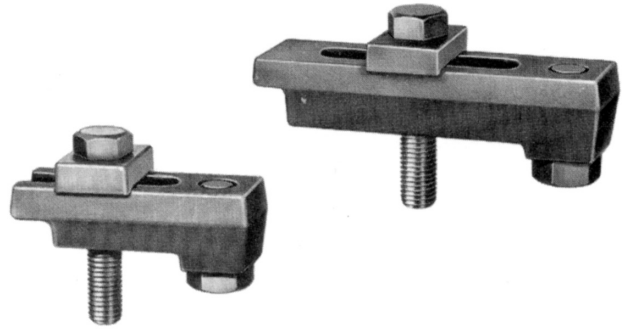

ITEM NO'S. MCA44 TO MCA67

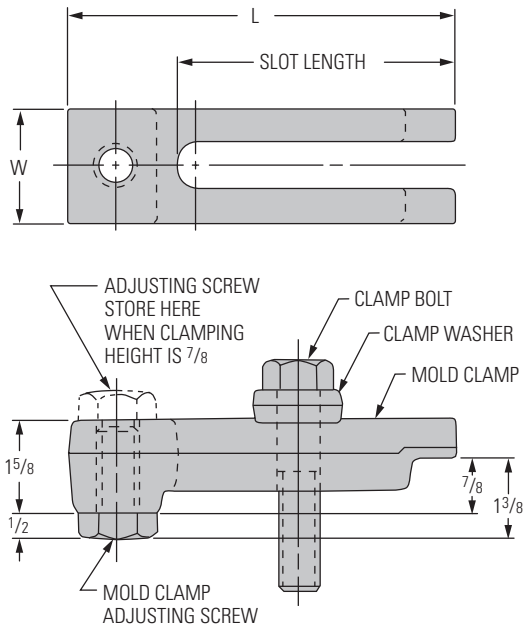

ITEM NO. MCA895

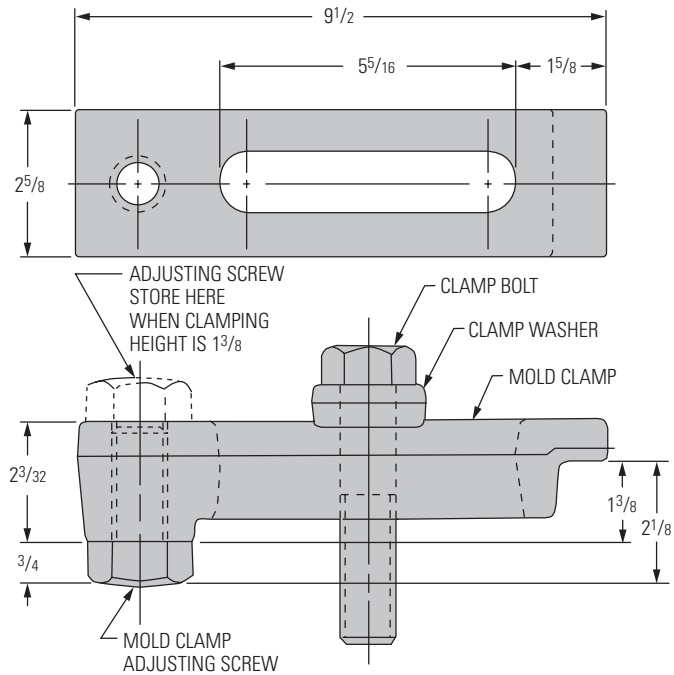

Mold Clamps for Plastics Molds – MCA

ITEM NUMBER	CLAMP DIMENSIONS			CLAMP SCREW SIZE (†) THD. x LENGTH	REPLACEMENT PARTS	
	L LENGTH	W WIDTH	SLOT LENGTH		CLAMP BOLT AND WASHER KIT	ADJUSTING SCREW
MCA44	43/16	15/8	213/16	1/2-13 x 3"	MCK4	MCAS5
MCA55	53/16	17/8	33/8	5/8-11 x 3 1/2"	MCK5	MCAS6
MCA57	7	17/8	5	5/8-11 x 3 1/2"		
MCA65	53/16	2	33/8	3/4-10 x 3 1/2"	MCK6	MCAS6
MCA67	7	2	5	3/4-10 x 3 1/2"		
MCA895	9 1/2	25/8	55/16	1-8 x 4 1/2"	MCK8	MCAS8

Mold Assembly consists of:

- 1 – Mold Clamp
- 1 – Clamp Washer
- 1 – Clamp Bolt
- 1 – Mold Clamp

†NOTE:

Mold Clamp Screws supplied with assembly are of high-tensile strength alloy steel. Lengths shown will accommodate clamping ledges up to a maximum of 1.375. For clamping ledges in excess of 1.375, use longer screws accordingly.

Hoist Rings – INCH

Installation and Ordering Information

Installation Data

Tap workpiece for hoist ring bolt with axis vertical to mounting surface. Work surface should

be flat and smooth to provide full 360° flush seating for the bushing flange. For installation in ferrous materials, the screw should be tightened to the full torque loading recommended in column TL below, +25% – 0.

(NOTE: Some loosening may develop after prolonged service in a permanent installation. It is advisable to periodically retighten the mounting bolt to maintain the specified torque value.) For maximum safety with soft metal workpieces such as aluminum, use extra length bolts with minimum effective thread engagement of 2 times thread diameter. The use of free fit spacers between the bushing flange and mounting surface is not recommended, as this will reduce the load rating on angularly applied loads. Hoist ring must be free to swivel 360° and pivot 180° at all times.

Material: Alloy steel (certified heat treatment), black oxide
Safety Factor: 5 times rated load in any direction
Range of Movement: 360° swivel; 180° pivot

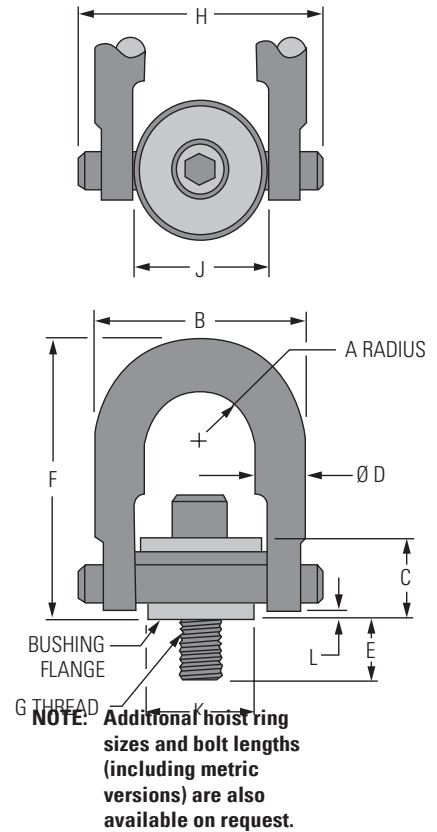
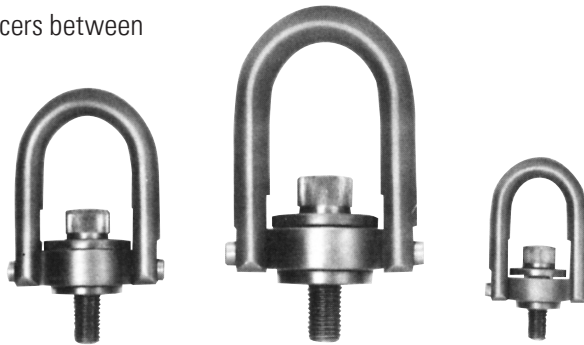

Hoist Rings – SHR (includes bolt and retaining ring)

ITEM NUMBER	RATED LOAD (LBS)	A RADIUS	B	C	Ø D	E EFFECTIVE THREAD PROJECTION	F	G	H CLEARANCE DIMENSION	J	K	L	TL** FOOT LBS	WEIGHT
SHR0001	800	7/16	15/8	41/64	3/8	9/16	25/8	5/16-18	2	1	3/4	3/32	7	5 OZ.
SHR0002	1,000	7/16	15/8	41/64	3/8	9/16	25/8	3/8-16	2	1	3/4	3/32	12	5 OZ.
SHR0003	2,500	7/8	31/4	15/32	3/4	3/4	43/4	1/2-13	35/8	2	11/2	3/32	28	2 LB. 5 OZ.
SHR0004	4,000	7/8	31/4	15/32	3/4	1	43/4	5/8-11	35/8	2	11/2	3/32	60	2 LB. 7 OZ.
SHR0005	5,000	7/8	31/4	15/32	3/4	1	43/4	3/4-10	35/8	2	11/2	3/32	100	2 LB. 9 OZ.
SHR0006	10,000	113/32	413/16	111/16	1	11/2	61/2	1"-8	51/8	3	25/16	17/64	230	7 LB.
SHR0007	15,000	13/4	6	21/8	11/4	17/8	83/4	11/4-7	61/2	33/4	31/4	11/32	470	14 LB.

**Recommended torque load +25% – 0

Replacement Bolt Kits – SHK (includes bolt and retaining ring)

ITEM NUMBER	USED WITH	SIZE	E
SHK0001	SHR0001	5/16 -18 X 11/4	9/16
SHK0002	SHR0002	3/8 -16 X 11/4	9/16
SHK0003	SHR0003	1/2 -13 X 2	3/4
*SHK0004		1/2 -13 X 21/4	1
SHK0005	SHR0004	5/8 -11 X 21/4	1
*SHK0006		5/8 -11 X 21/2	11/4
SHK0007	SHR0005	3/4 -10 X 21/4	1
*SHK0008		3/4 -10 X 23/4	11/2
SHK0009	SHR0006	1"-8 X 31/4	11/2
*SHK0010		1"-8 X 33/4	2
SHK0011	SHR0007	11/4 -7 X 4	17/8



NOTES:

E = Effective Thread Projection

Bolts not marked with an asterisk () are identical to those supplied with hoist rings. Bolts marked with an asterisk are longer to provide thread projection of twice the bolt diameter, recommended for use with softer metals.

Quick-Change Components Ear Plates for T-Style Insert Molds

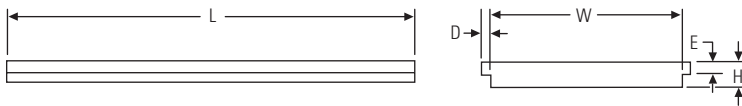
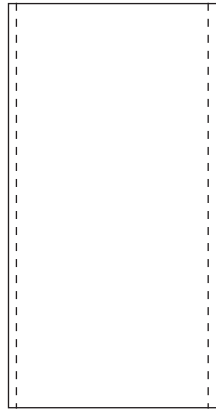
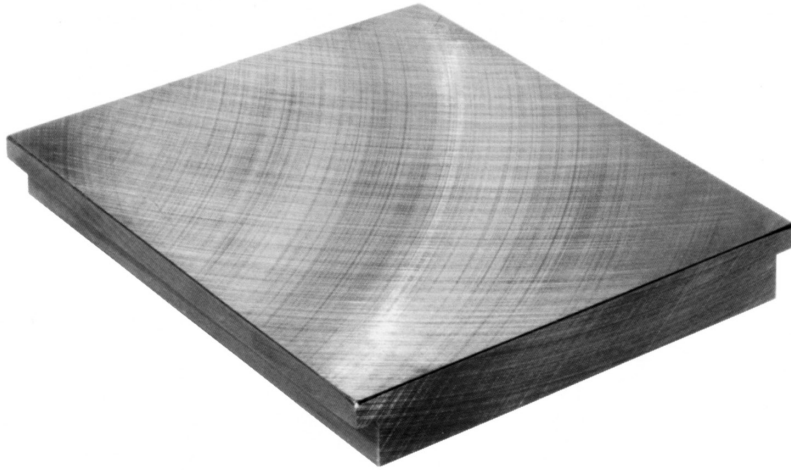

Ear Plates for T-Style Insert Molds

ITEM NO.	W	L	H	E	D
05/05EPU	3.248	3.750	0.450	0.184	0.175
07/07EPU	4.496	6.250	0.625	0.246	0.230
08/09EPU	4.996	8.000	0.750	0.246	0.230
08/10EPU	4.996	9.000	0.750	0.246	0.230
84/90EPU	6.496	8.000	0.750	0.246	0.230
09/07EPU	5.996	6.000	0.750	0.246	0.230
09/07EPE	5.996	6.000	0.750	0.246	0.230
10/12EPU	6.996	10.874	1.000	0.494	0.360
10/14EPU	6.996	12.874	1.000	0.494	0.360
10/16EPU	6.996	14.874	1.000	0.494	0.360
11/11EPU	7.996	10.000	1.000	0.494	0.360
12/08EPU	7.996	7.000	1.000	0.494	0.360
12/14EPU	7.994	12.874	1.000	0.494	0.360
12/16EPU	7.994	14.874	1.000	0.494	0.360
12/18EPU	7.994	16.874	1.000	0.494	0.360
12/20EPU	7.994	18.874	1.000	0.494	0.360
13/16EPU	8.994	14.874	1.000	0.494	0.360
13/18EPU	8.994	16.874	1.000	0.494	0.360
13/20EPU	8.994	18.874	1.000	0.494	0.360
13/22EPU	8.994	20.874	1.000	0.494	0.360
14/16EPU	9.994	14.874	1.000	0.494	0.360
14/18EPU	9.994	16.874	1.000	0.494	0.360
14/20EPU	9.994	18.874	1.000	0.494	0.360
14/22EPU	9.994	20.874	1.000	0.494	0.360
16/18EPU	10.994	15.874	1.500	0.744	0.450
16/21EPU	10.994	18.874	1.500	0.744	0.450
16/24EPU	10.994	21.874	1.500	0.744	0.450
16/27EPU	10.994	24.874	1.500	0.744	0.450
18/20EPU	11.994	17.874	1.500	0.744	0.450
18/26EPU	11.994	23.874	1.500	0.744	0.450

Ordering Information for Ear Plates for T-Style Insert Molds

- Item number and description
- First four digits of item number must match those of companion insert molds
- Item number is for a set of two (2) plates
- Steel grade: Prehard (240-330 BHN) unless otherwise specified

Quick-Change Components Standard Ejector Plate Sets

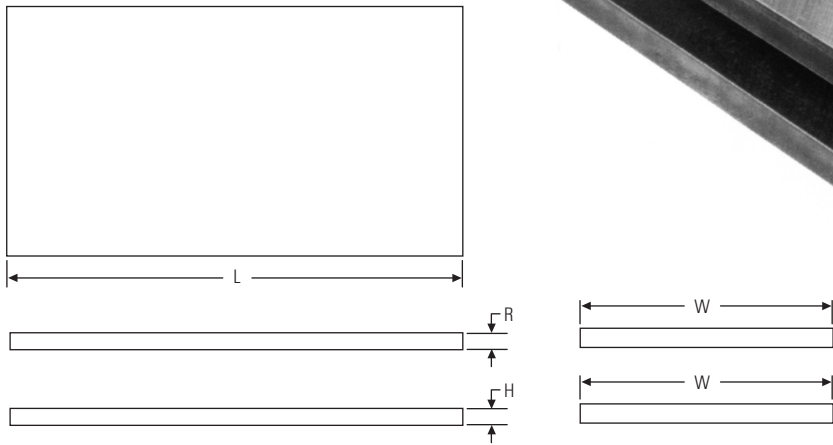
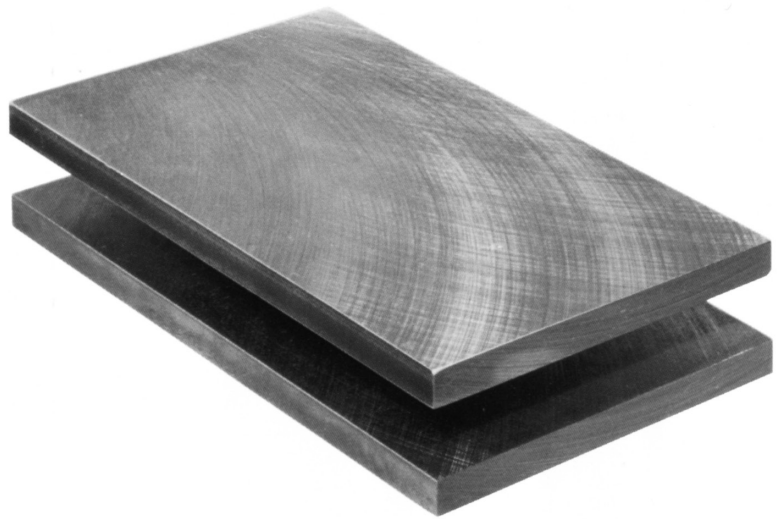

Standard Ejector Plate Sets for U Frame Series

ITEM NO.	R	H	W	L
05/05EJU	0.240	0.240	2.75	3.62
07/07EJU	0.360	0.360	3.87	6.00
08/09EJU	0.360	0.360	4.00	7.88
08/10EJU	0.360	0.360	4.00	8.88
84/90EJU	0.360	0.360	5.50	7.87
09/07EJE	0.360	0.360	5.00	5.88
10/12EJU	0.480	0.480	6.00	10.75
10/14EJU	0.480	0.480	6.00	12.75
10/16EJU	0.480	0.480	6.00	14.75
11/11EJU	0.480	0.480	7.00	9.88
12/08EJU	0.360	0.360	7.00	6.88
12/14EJU	0.480	0.480	7.00	12.75
12/16EJU	0.480	0.480	7.00	14.75
12/18EJU	0.480	0.480	7.00	16.75
12/20EJU	0.480	0.480	7.00	18.75
13/16EJU	0.480	0.480	8.00	14.75
13/18EJU	0.480	0.480	8.00	16.75
13/20EJU	0.480	0.480	8.00	18.75
13/22EJU	0.480	0.480	8.00	20.75
14/16EJU	0.480	0.480	9.00	14.75
14/18EJU	0.480	0.480	9.00	16.75
14/20EJU	0.480	0.480	9.00	18.75
14/22EJU	0.480	0.480	9.00	20.75
16/18EJU	0.600	0.600	9.75	15.75
16/21EJU	0.600	0.600	9.75	18.75
16/24EJU	0.600	0.600	9.75	21.75
16/27EJU	0.600	0.600	9.75	24.75
18/20EJU	0.600	0.600	10.75	17.75
18/26EJU	0.600	0.600	10.75	23.75

Standard Ejector Plate Sets for H Frame Series

ITEM NO.	R	H	W	L
07/07EJH	0.240	0.240	2.75	3.00
08/09EJH	0.360	0.360	4.00	3.00
10/12EJH	0.360	0.360	4.00	4.50
10/18EJH	0.360	0.360	4.00	7.50
11/14EJH	0.360	0.360	5.00	5.50
11/18EJH	0.360	0.360	5.00	7.50
12/11EJH	0.360	0.360	6.00	4.00
12/13EJH	0.360	0.360	6.00	5.00
12/15EJH	0.360	0.360	6.00	6.00
12/19EJH	0.360	0.360	6.00	8.00
13/13EJH	0.360	0.360	7.00	5.00
13/15EJH	0.360	0.360	7.00	6.00
13/17EJH	0.360	0.360	7.00	7.00
13/19EJH	0.360	0.360	7.00	8.00
13/23EJH	0.360	0.360	7.00	10.00
14/15EJH	0.360	0.480	8.00	6.00
14/17EJH	0.360	0.480	8.00	7.00
14/19EJH	0.360	0.480	8.00	8.00
14/21EJH	0.360	0.480	8.00	9.00
14/25EJH	0.360	0.480	8.00	11.00
15/15EJH	0.360	0.480	8.75	5.88
15/17EJH	0.360	0.480	8.75	6.88
15/19EJH	0.360	0.480	8.75	7.88
15/21EJH	0.360	0.480	8.75	8.88
15/25EJH	0.360	0.480	8.75	10.88
17/19EJH	0.480	0.600	9.75	7.88
17/26EJH	0.480	0.600	9.75	11.38
18/22EJH	0.480	0.600	10.75	9.38
18/26EJH	0.480	0.600	10.75	11.38
18/30EJH	0.480	0.600	10.75	13.38

Standard Ejector Plate Sets for Double H Frame Series

ITEM NO.	R	H	W	L
12/08EJD	0.240	0.240	2.75	3.00
16/09EJD	0.360	0.360	4.00	3.00
16/12EJD	0.360	0.360	4.00	4.50
16/18EJD	0.360	0.360	4.00	7.50
20/14EJD	0.360	0.360	5.00	5.50
22/19EJD	0.360	0.360	6.00	8.00
24/23EJD	0.360	0.360	7.00	10.00

Standard Ejector Plate Sets for Removable Center Bar Series

ITEM NO.	R	H	W	L
08/10EJB	0.360	0.360	4.00	3.88
84/90EJB	0.360	0.360	5.50	3.38
11/11EJB	0.480	0.480	7.00	3.88

Ordering Information for Standard Ejector Plate Sets

- Item number and description
- First four digits of item number must match those of companion insert molds
- Item number is for a set of two (2) plates
- Steel grade: Mild



Quick-Change Components Guide Posts

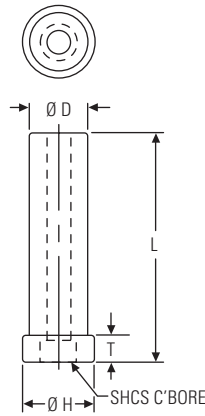

Mold Retainer Pillars

ITEM NO.	L	D	H	T	SHCS
MRP1025	2.501	.75	1.00	.350	5/16-18
MRP1026	2.626	.75	1.00	.350	5/16-18
MRP1037	3.751	1.00	1.25	.350	3/18-16
MRP1041	4.126	1.00	1.25	.350	3/18-16
MRP1035	3.501	1.00	1.25	.470	3/18-16
MRP1040	4.001	1.00	1.25	.470	3/18-16

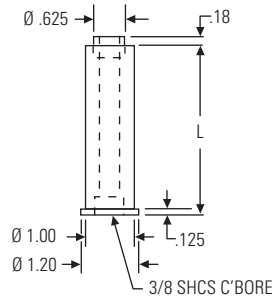
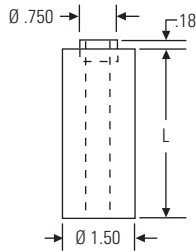
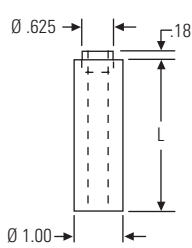

ITEM NO.	LENGTH
AGP120	2.501
AGP125	2.563
AGP128	2.876
AGP131	3.126
AGP134	3.438
AGP136	3.688

ITEM NO.	LENGTH
AGP234	3.438
AGP235	3.501
AGP236	3.688
AGP237	3.751
AGP243	4.376

ITEM NO.	LENGTH
CSP125	2.501
CSP127	2.751
CSP135	3.501
CSP140	4.001

Furnished with PPAB-6.

Furnished with PPAB-7.

Furnished with PPAB-6.

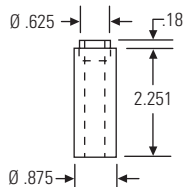

ITEM NO.
AGP875

Furnished with PPAB-6.

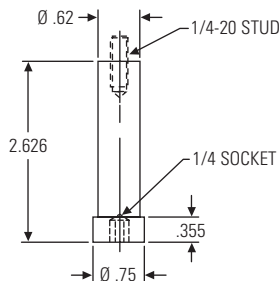

ITEM NO.
CBP0809

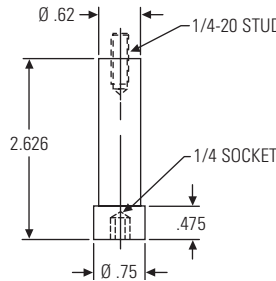

ITEM NO.
CBP8490

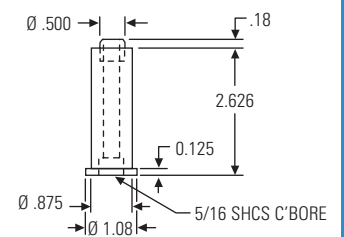

ITEM NO.
AGP826

Insert mold guide post
furnished with PPAB-5.

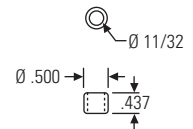

ITEM NO.
PPAB-5

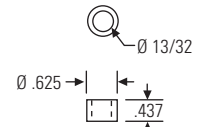

ITEM NO.
PPAB-6

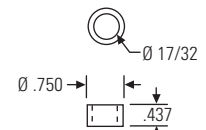

ITEM NO.
PPAB-7



Quick-Change Components Guide Bushings

Guide Bushings



MUD® Quick-Change Components for Mold Frames & Inserts

Guide Bushings

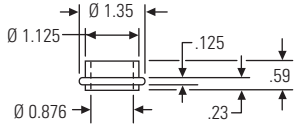

ITEM NO.
AGB360

Insert mold guide bushing.

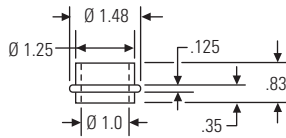

ITEM NO.
AGB480

Insert mold guide bushing.

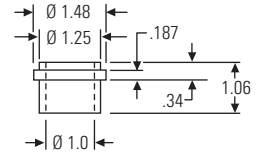

ITEM NO.
RCS-0010

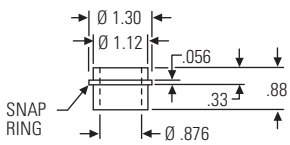

ITEM NO.
MUD®2-0087

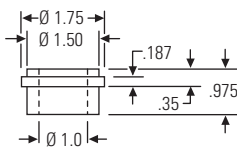

ITEM NO.
CB-0010

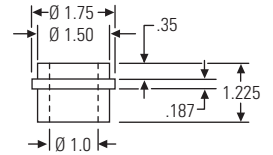

ITEM NO.
MUD®2-0010-8

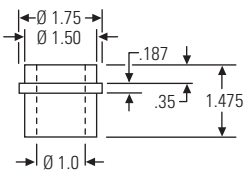

ITEM NO.
MUD®2-0010-11

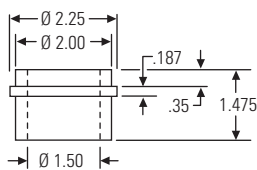
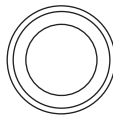

ITEM NO.
MUD®2-0015-11

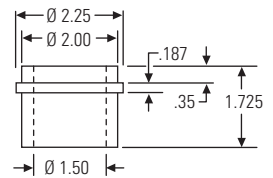
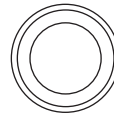

ITEM NO.
MUD®2-0015-13

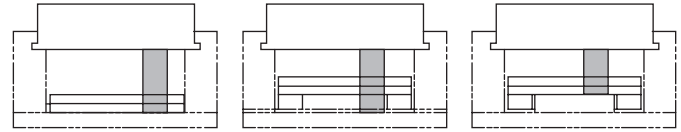
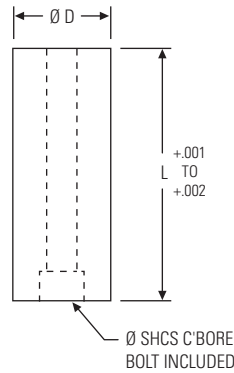
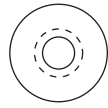

Quick-Change Components Insert Mold Pillar Posts

FRAME WITHOUT
EJECTOR PLATEFRAME WITH EJECTOR
PLATE AND NO PADFRAME WITH EJECTOR
PLATE AND SUPPORT PAD

DME cold-rolled steel pillar posts are precision ground to length for MUD® Quick-Change systems. Each is predrilled and supplied with socket head cap screws for easy installation in insert molds.

Frames supplied with master ejector plates are supplied standard with pillar post pads. The pillar post pad is the same height as the height of the ejection. In cases where pillar post pads are not utilized, the pillar post will rest on the back clamp plate. All molds require pillar posts and the pillar post will be precision ground .001 to .002 higher than the height of ejection.

Insert Mold Pillar Posts

ITEM NO.	DIAMETER	LENGTH	BOLT
MPP1025	1.00	2.500	5/16
MPP1026	1.00	2.625	5/16
MPP1035	1.00	3.500	5/16
MPP1037	1.00	3.750	3/8
MPP1040	1.00	4.000	3/8
MPP1041	1.00	4.125	3/8
MPP1225	1.25	2.500	5/16
MPP1226	1.25	2.625	5/16
MPP1235	1.25	3.500	5/16
MPP1237	1.25	3.750	3/8
MPP1240	1.25	4.000	3/8
MPP1241	1.25	4.125	3/8
MPP1525	1.50	2.500	5/16
MPP1526	1.50	2.625	5/16
MPP1535	1.50	3.500	5/16
MPP1537	1.50	3.750	3/8
MPP1540	1.50	4.000	3/8
MPP1541	1.50	4.125	3/8

Bolt included with each pillar post.
Other sizes available on request.

Quick-Change Components Hardened Runner Pads

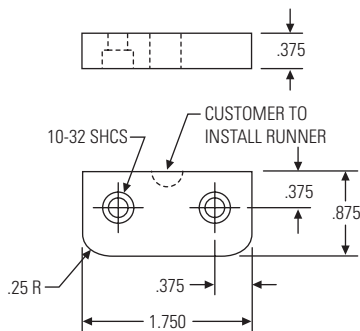

ITEM NO.

09/07HRP

One required for each insert mold half.

Includes (2) 10-32 x 21/2" cap screw.

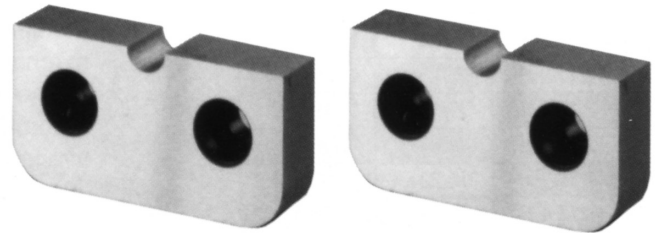

Hardened Runner Pads

DME hardened runner pads are designed for installation in insert molds ordered for MUD® Quick-Change shuttle frame applications (09/07UF, 09/07EB and 12/08UF). These pads allow the molding machine injection nozzle to contact the companion insert mold without damage.

Quick-Change Components Shoulder Screws, Sprue Plugs & Rest Buttons

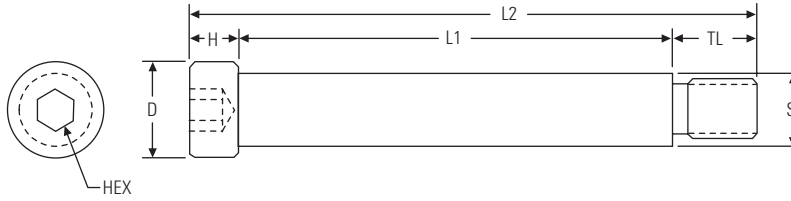

Frame Shoulder Screws

ITEM NO.	S	TL	L1	L2	H	D	HEX	THD
SS5022	0.498	0.63	2.250	3.19	0.312	0.750	1/4	3/8-16
SS5030	0.498	0.63	3.000	3.94	0.312	0.750	1/4	3/8-16
SS6230	0.623	0.75	3.000	4.13	0.375	0.875	5/16	1/2-13
SS6240	0.623	0.75	4.000	5.13	0.375	0.875	5/16	1/2-13
SS6245	0.623	0.75	4.500	5.63	0.375	0.875	5/16	1/2-13
SS7545	0.748	0.88	4.500	5.88	0.500	1.000	3/8	5/8-11
SS7555	0.748	0.88	5.500	6.88	0.500	1.000	3/8	5/8-11

Shoulder screws are installed in H frames and Double H frames to align the bottom clamp plate and ejector rails with the support plate.



Sprue Puller Plugs

ITEM NO.	P	B	D
SPP25-13	0.250	1.377	0.336
SPP25-18	0.250	1.877	0.336
SPP25-23	0.250	2.377	0.336
SPP25-28	0.250	2.877	0.336
SPP31-13	0.312	1.377	0.367
SPP31-18	0.312	1.877	0.367
SPP31-23	0.312	2.377	0.367
SPP31-28	0.312	2.877	0.367
SPP31-33	0.312	3.377	0.367
SPP31-38	0.312	3.877	0.367
SPP38-13	0.375	1.377	0.430
SPP38-18	0.375	1.877	0.430
SPP38-23	0.375	2.377	0.430
SPP38-28	0.375	2.877	0.430
SPP38-33	0.375	3.377	0.430
SPP38-38	0.375	3.877	0.430

Sprue puller plugs are installed in the center section of H frame and Double H frame ejector halves. Each center section has a 1.000 hole to accept this plug. The plug has been machined to receive three pin and puller sizes for accommodating a range of sprue and runner sizes.

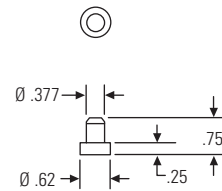
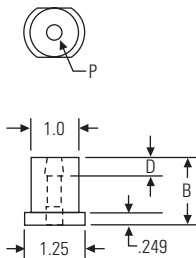

Rest Buttons

ITEM NO.

RB62

Rest buttons are installed in master ejector plates.



Quick-Change Components Insert Mold Holding Clamps

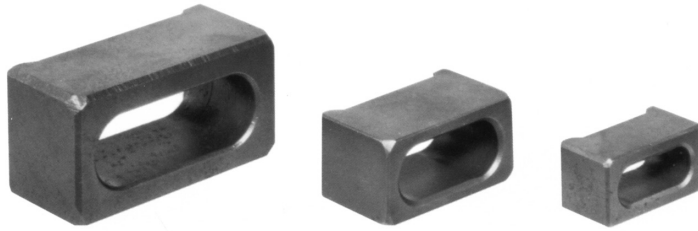

Insert Mold Holding Clamps

ITEM NO.	W	L	H	T
UC3862	(see drawing below left)			
UC2520	0.50	1.00	0.50	0.27
UC3816	0.62	1.25	0.75	0.40
UC5013	1.00	1.88	1.00	0.53

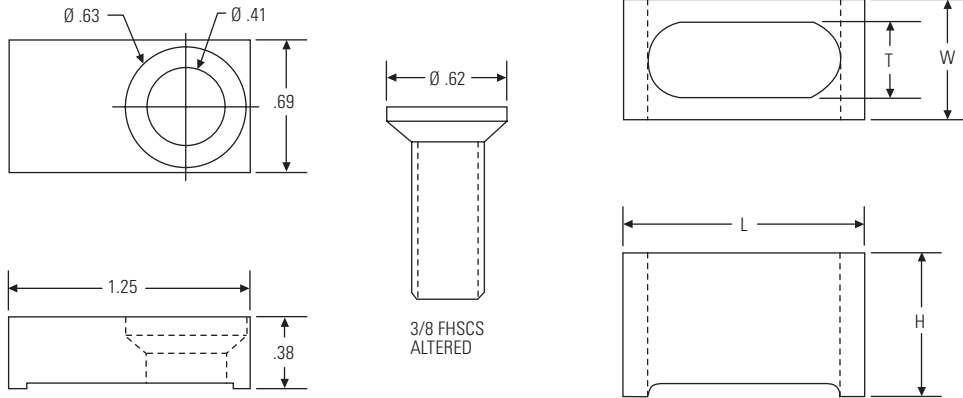

UC3862 insert mold holding clamp is designed for 09/07 UF 321 frame when clearance between machine safety gate and frame is minimal.

Quick-Change Components Mold Base Adapter Frame Rollers

Adapter Frame Rollers

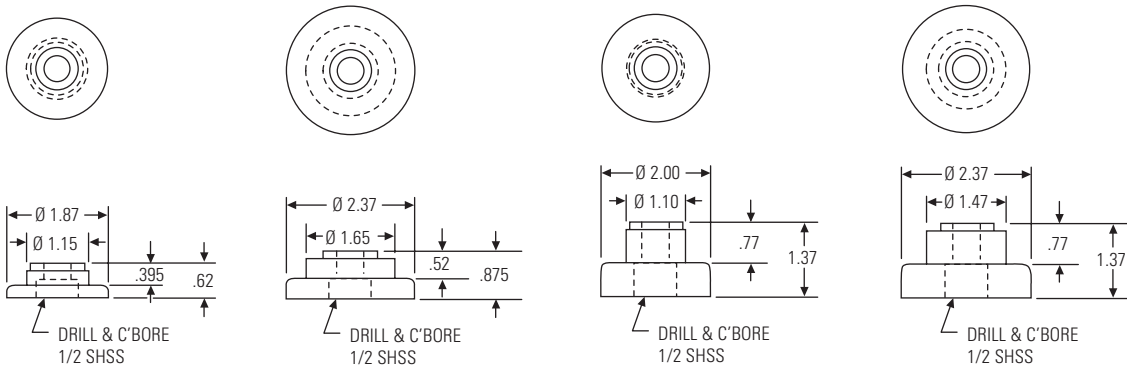

ITEM NO.
MBAR375-18

ITEM NO.
MBAR500-23

ITEM NO.
MBAR750-20

ITEM NO.
MBAR750-23

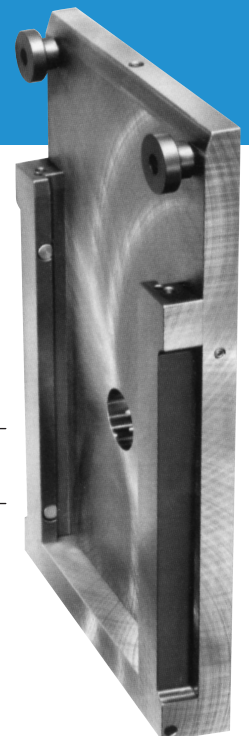

MUD® Quick-Change Components for Mold Frames & Inserts | Holding Clamps & Frame Rollers





Quick-Change Options for Mold Frames & Inserts

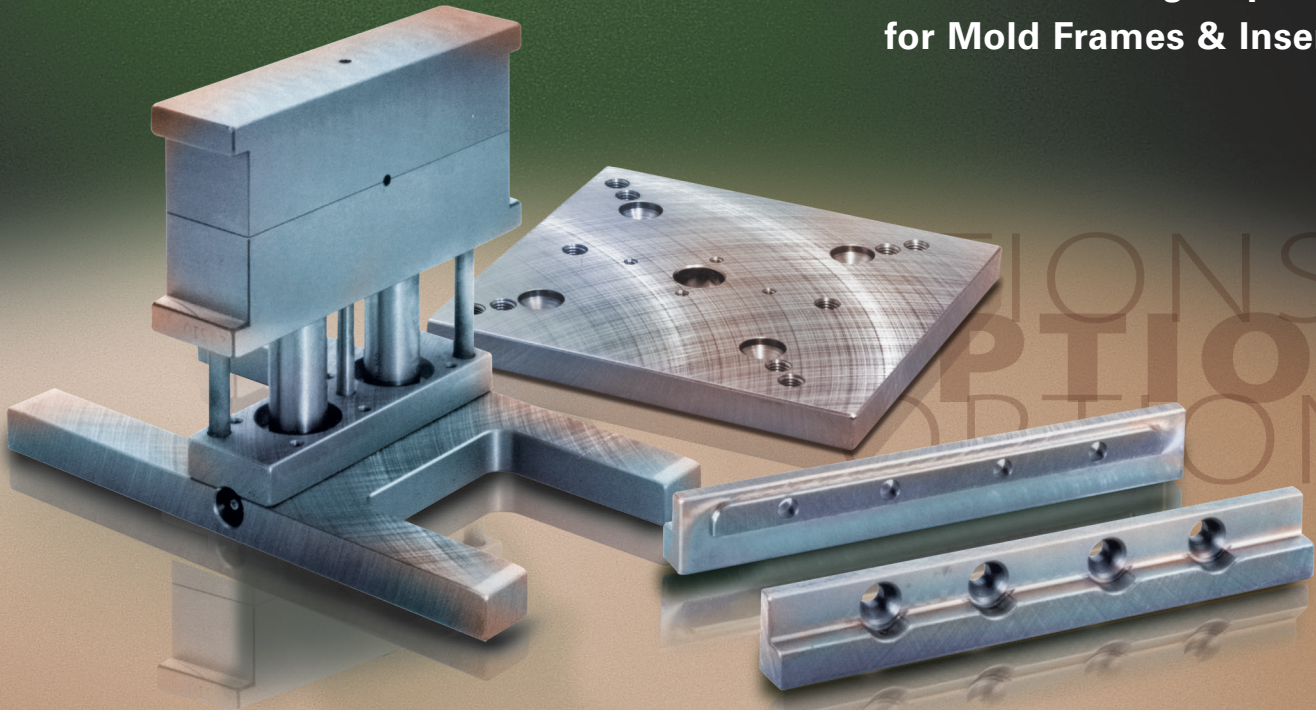

Mold and Die Steels

STEELS FOR STRUCTURAL SECTIONS

DME No. 1 Steel

No. 1 Steel is a medium carbon (SAE 1030), silicon-killed forging quality steel with approximately 25% greater tensile strength than typical low-carbon warehouse steels. It machines easily, but is not "sticky," permitting a faster and smoother cut.

DME No. 2 Steel

No. 2 Steel is an AISI 4130 type steel. It is supplied pre-heat treated to 28-34 HRC (271-321 Bhn). A high-strength steel, it is ideal for cavity and core retainer plates, clamping plates and support plates in molds and dies.

STEELS FOR CAVITIES AND CORES

DME No. 3 Steel

No. 3 Steel is a P-20 AISI 4130 (modified) type cavity steel. Exceptionally clean, it is pre-heat treated to 28-34 HRC (271-321 Bhn). It provides high hardness, good machinability and exceptional polishability for both plastics molds and die cast dies.

DME No. 5 Steel

No. 5 Steel is a thermal shock resistant, hotwork die steel (AISI-SAE H-13 type). Supplied fully annealed 13-20 HRC (approx. 200 Bhn) for easy machinability, it can be subsequently heat treated to the desired hardness with a minimum of deformation. Mainly used for die cast dies, it is also suitable for plastics molds with exceptional hardness or polishability requirements. DME No. 5 Steel meets or exceeds the acceptance criteria established by the NADCA as detailed in Technical Digest Number 01-80-01D.

MUD® Quick-Change Options features and applications

The wide range of available options enhance the exceptional design versatility of the Master Unit Die Concept. These options can also increase the cost saving benefits and time saving features of this superior approach to injection molding.

The basic design of MUD® Quick-Change frames and companion insert molds adds to these advantages. The open configuration of the frame permits installation of water lines or hydraulic cylinders in the insert mold. The smaller size and lighter weight of insert molds simplifies machining. These design features also simplify routine maintenance.

Frame options include interlocking ejector rails to lock the insert mold's ejector system to the master ejector plate. The master ejector plate can be spring loaded for returning the insert mold's ejector system. It can also be tied to the machine's hydraulic knockout system for stroking the insert mold's ejector assembly.

Other frame options include water lines in the center bar or other locations, insulation boards, runner shutoffs and hot tip sprue bushings. Frame spacer bars to accommodate shorter, more economical companion insert molds are available for frames designed for longer sizes. Additional retainer slots and a spacer plate in the frame's cavity half allow the frame to accept insert molds with different thicknesses. Either option results in greater production and scheduling flexibility.

MUD® Quick-Change U frames can be adapted to multiple insert molding similar to H frames with the addition of an optional removable center runner bar and a master ejector plate. This allows simultaneous molding with two smaller insert molds.

Design options for insert molds include spring loading, early return, unscrewing mechanisms, hot runner molding and machining for cam slides. Insert molds can be ordered with interlocking ejector plates for stroking action when used with frames having an interlocking ejector system.

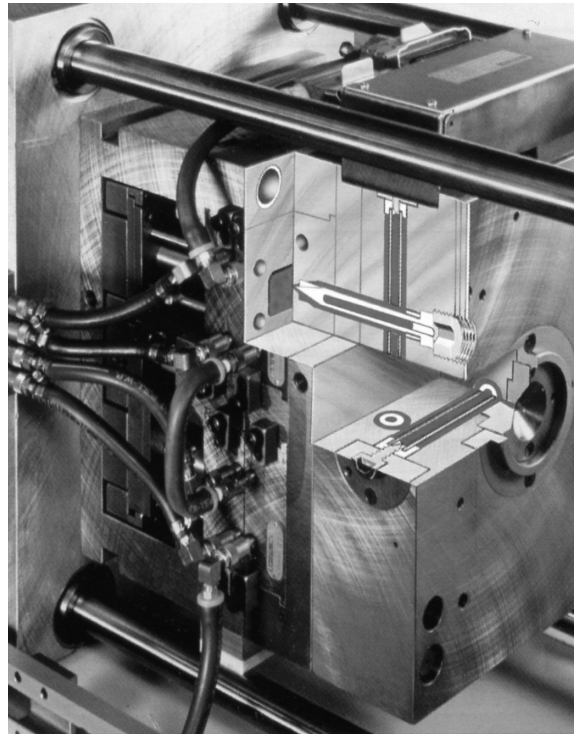

Insert molds are available with a complete ejector system including return pins and pillar posts. Other options include stripper plates, sleeve ejection and three-plate construction for a pinpoint gating system. Machining is also available for heater cartridge holes, water lines, rough or finished pockets, taper locks and other special applications.

The addition of a hot manifold brings all of the advantages of the Quick-Change Concept to hot runner molding. Since both the frame and the hot runner system remain in the molding machine, only the insert molds are changed for new parts. This means faster changeovers, lower tooling costs and greater scheduling flexibility for hot runner systems, too.

MUD® Quick-Change tooling combined with the options and accessories included in the following pages offer mold makers, design engineers and manufacturing engineers the most efficient system in the plastics industry.

Quick-Change Options Sleeve Ejector Plate Assemblies

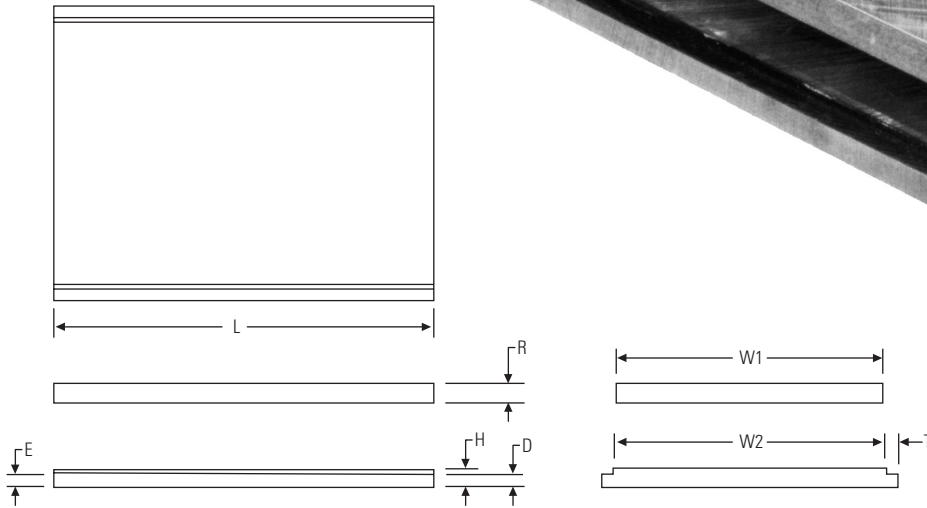
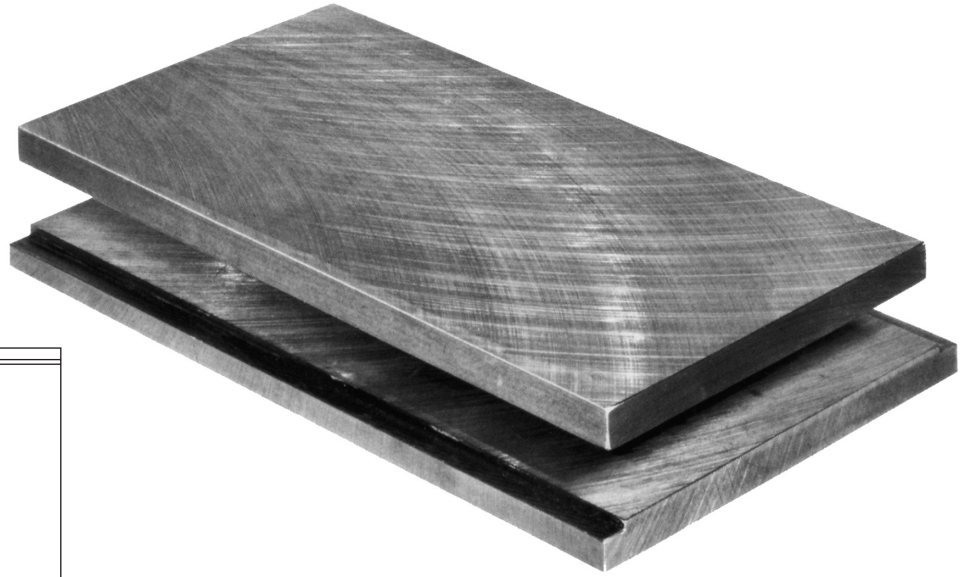

Ordering Information for Sleeve Ejector Plate Assemblies

- Item number and description (see table at right)
- First four digits of item number must match those of companion frame
- Item number is for a set of two (2) plates
- Steel grade: Mild

Sleeve Ejector Plate Assemblies

ITEM NO.	W1	W2	L	R	H	E	D	T
05/05SEPU	2.75	2.81	3.62	0.240	0.175	0.123	0.107	0.15
07/07SEPU	3.88	4.00	6.00	0.360	0.360	0.185	0.159	0.18
08/09SEPU	4.00	4.00	7.88	0.360	0.360	0.283	0.247	0.25
08/10SEPU	4.00	4.12	8.87	0.360	0.360	0.287	0.248	0.25
84/90SEPU	5.50	5.62	7.88	0.360	0.360	0.283	0.247	0.25
10/12SEPU	6.00	6.12	10.75	0.480	0.480	0.477	0.429	0.25
10/14SEPU	6.00	6.12	12.75	0.480	0.480	0.477	0.420	0.25
10/16SEPU	6.00	6.12	14.75	0.480	0.480	0.477	0.412	0.25
11/11SEPU	7.00	7.12	9.88	0.360	0.360	0.331	0.287	0.25
12/14SEPU	7.00	7.12	12.75	0.480	0.480	0.477	0.420	0.25
12/16SEPU	7.00	7.12	14.75	0.480	0.480	0.477	0.412	0.25
12/18SEPU	7.00	7.12	16.75	0.480	0.480	0.477	0.403	0.25
12/20SEPU	7.00	7.12	18.75	0.480	0.480	0.477	0.399	0.25
13/16SEPU	8.00	8.12	14.75	0.480	0.480	0.477	0.412	0.25
13/18SEPU	8.00	8.12	16.75	0.480	0.480	0.477	0.403	0.25
13/20SEPU	8.00	8.12	18.75	0.480	0.480	0.477	0.394	0.25
13/22SEPU	8.00	8.12	20.75	0.480	0.480	0.477	0.385	0.25
14/16SEPU	9.00	9.12	14.75	0.480	0.480	0.477	0.412	0.25
14/18SEPU	9.00	9.12	16.75	0.480	0.480	0.477	0.403	0.25
14/20SEPU	9.00	9.12	18.75	0.480	0.480	0.477	0.394	0.25
14/22SEPU	9.00	9.12	20.75	0.480	0.480	0.477	0.385	0.25
16/18SEPU	9.75	9.88	15.75	0.600	0.600	0.477	0.407	0.25
16/21SEPU	9.75	9.88	18.75	0.600	0.600	0.477	0.395	0.25
16/24SEPU	9.75	9.88	21.75	0.600	0.600	0.477	0.381	0.25
16/27SEPU	9.75	9.88	24.75	0.600	0.600	0.477	0.368	0.25
18/20SEPU	10.75	10.88	17.75	0.600	0.600	0.477	0.398	0.25
18/26SEPU	10.75	10.88	23.75	0.600	0.600	0.477	0.372	0.25



Quick-Change Options Interlocking Ejector Plate Rails

Interlocking ejector system designed for two-unit H frames and four-unit Double H frames

MUD® H frames and Double H frames are available with interlocking ejector systems. These systems, based on rails precisely located on the frame's master ejector plate, allow the option of tying the insert mold's ejector system to the master ejector plate.

The insert mold's bottom ejector plate is wider to slide into the rails mounted on the frame's master ejector plate. The interlocking master ejector plate may be spring loaded or tied to the hydraulic knockout plate of the molding machine.

Tying the master ejector plate to the machine's hydraulic knockout system allows multiple stroking of the insert mold ejector system which assists in the automatic operation of the insert mold. This option is available on predrilled existing frames manufactured after June 1990.

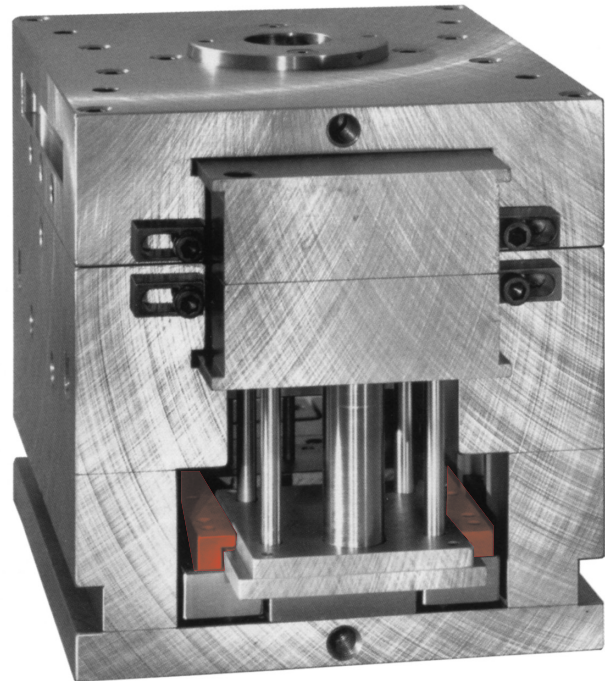

H Frame Series Interlocking Ejector Plate Rails

ITEM NO.	FRAME SIZE
08/09IFH	08/09
10/12IFH	10/12
10/18IFH	10/18
11/14IFH	11/14
11/18IFH	11/18
12/11IFH	12/11
12/13IFH	12/13
12/15IFH	12/15
12/19IFH	12/19
13/13IFH	13/13
13/15IFH	13/15
13/17IFH	13/17
13/19IFH	13/19
13/23IFH	13/23
14/15IFH	14/15
14/17IFH	14/17
14/19IFH	14/19
14/21IFH	14/21
14/25IFH	14/25
15/15IFH	15/15
15/17IFH	15/17
15/19IFH	15/19
15/21IFH	15/21
15/25IFH	15/25
17/19IFH	17/19
17/26IFH	17/26
18/22IFH	18/22
18/26IFH	18/26
18/30IFH	18/30

Double H Frame Series Interlocking Ejector Plate Rails

ITEM NO.	FRAME SIZE
16/09IFD	16/09
16/12IFD	16/12
16/18IFD	16/18
20/14IFD	20/14
22/19IFD	22/19
24/23IFD	24/23

Ordering Information for Interlocking Ejector Plate Rails

- Item number and description (see tables at right)
- First four digits of item number must match those of companion insert molds
- Item number is for a set of four (4) rails for H frames and eight (8) rails for DH frames
- See page OP 138 for companion ejector plates

Quick-Change Options Interlocking Ejector Plates

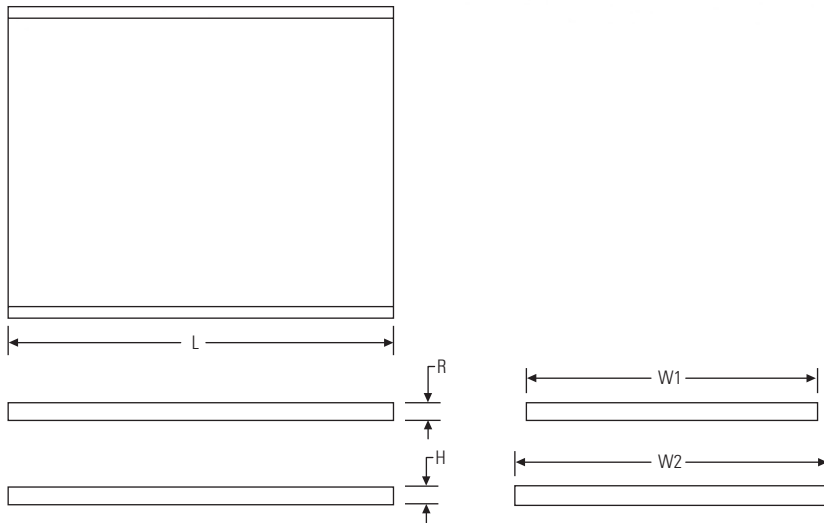
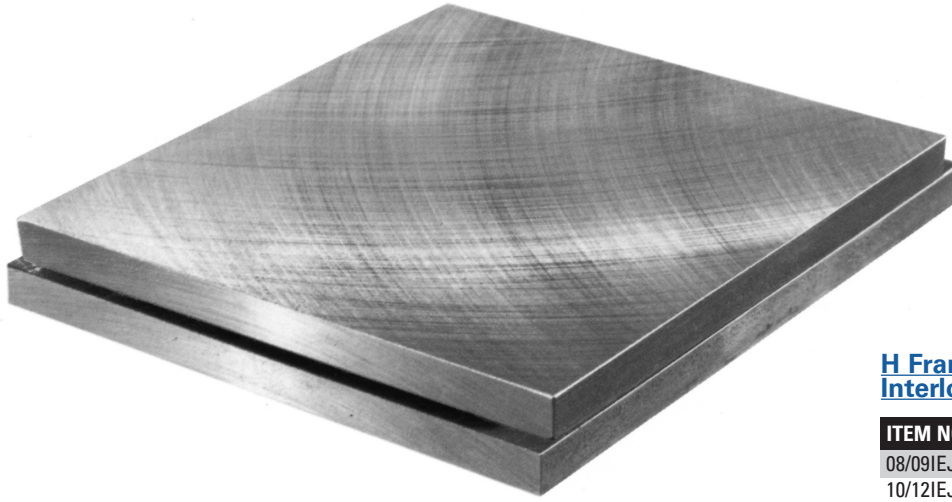

Ordering Information for Interlocking Ejector Plates

- Item number and description (see tables at right)
- First four digits of item number must match those of companion insert molds
- Item number is for a set of two (2) plates
- Steel grade: Mild

H Frame Series Interlocking Ejector Plates

ITEM NO.	W1	W2	L	R	H
08/09IEJH	4.00	4.50	3.00	0.360	0.360
10/12IEJH	4.00	4.50	4.50	0.360	0.360
10/18IEJH	4.00	4.50	7.50	0.360	0.360
11/14IEJH	5.00	5.50	5.50	0.360	0.360
11/18IEJH	5.00	5.50	7.50	0.360	0.360
12/11IEJH	6.00	6.50	4.00	0.360	0.360
12/13IEJH	6.00	6.50	5.00	0.360	0.360
12/15IEJH	6.00	6.50	6.00	0.360	0.360
12/19IEJH	6.00	6.50	8.00	0.360	0.360
13/13IEJH	7.00	7.50	5.00	0.360	0.360
13/15IEJH	7.00	7.50	6.00	0.360	0.360
13/17IEJH	7.00	7.50	7.00	0.360	0.360
13/19IEJH	7.00	7.50	8.00	0.360	0.360
13/23IEJH	7.00	7.50	10.00	0.360	0.360
14/15IEJH	8.00	8.50	6.00	0.360	0.480
14/17IEJH	8.00	8.50	7.00	0.360	0.480
14/19IEJH	8.00	8.50	8.00	0.360	0.480
14/21IEJH	8.00	8.50	9.00	0.360	0.480
14/25IEJH	8.00	8.50	11.00	0.360	0.480
15/15IEJH	8.75	9.25	5.88	0.360	0.480
15/17IEJH	8.75	9.25	6.88	0.360	0.480
15/19IEJH	8.75	9.25	7.88	0.360	0.480
15/21IEJH	8.75	9.25	8.88	0.360	0.480
15/25IEJH	8.75	9.25	10.88	0.360	0.480
17/19IEJH	9.75	10.25	7.88	0.480	0.600
17/26IEJH	9.75	10.25	11.38	0.480	0.600
18/22IEJH	10.75	11.25	9.38	0.480	0.600
18/26IEJH	10.75	11.25	11.38	0.480	0.600
18/30IEJH	10.75	11.25	13.38	0.480	0.600

Double H Frame Series Interlocking Ejector Plates

ITEM NO.	W1	W2	L	R	H
16/09IEJD	4.00	4.50	3.00	0.360	0.360
16/12IEJD	4.00	4.50	4.50	0.360	0.360
16/18IEJD	4.00	4.50	7.50	0.360	0.360
20/14IEJD	5.00	5.50	5.50	0.360	0.360
22/19IEJD	6.00	6.50	8.00	0.360	0.360
24/23IEJD	7.00	7.50	10.00	0.360	0.360



Quick-Change Options

U Frames with Master Ejector Systems

Ordering Information for U Frame with Master Ejector System

- Item number and description (see table below right)
- "S" diameter of locating ring supplied standard 3.990
- Sprue bushing (if required) – "R" spherical radius of sprue bushing furnished 1/2" or 3/4"
- "O" small diameter of sprue orifice furnished 7/32", 9/32" or 11/32"; 5/32" available on request
- Optional locating rings and sprue bushings
- Knockout hole locations standard as shown (others optional)
- Clamp slots as shown
- Mounting holes optional
- Additional ejection height available (quotation on request)
- Optional interlocking ejector plate rails available (quotation on request)
- Frames standard in prehard steel; prehard stainless and other steel grades available (quotation on request)

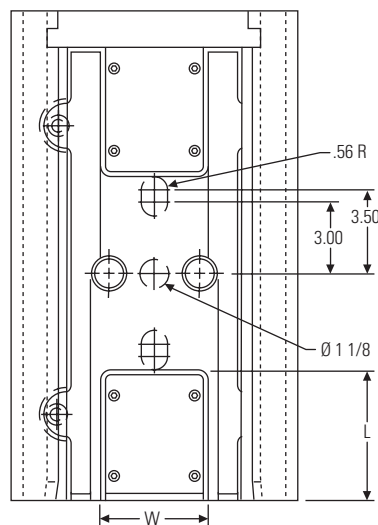
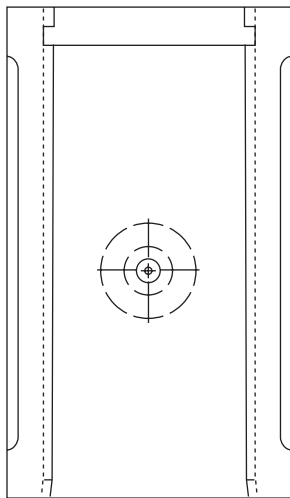
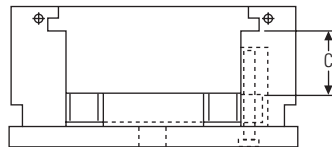
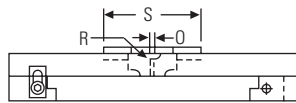
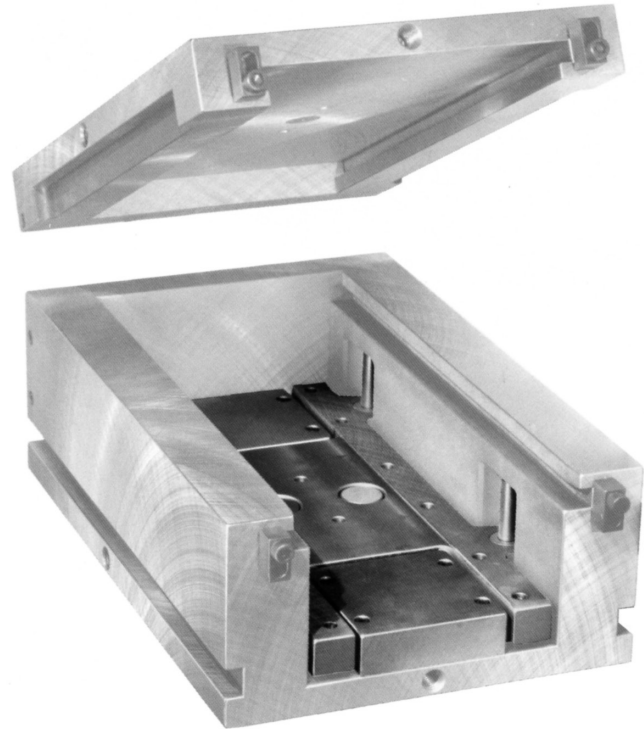

MUD® U frames with master ejector systems are designed to accept one Quick-Change insert mold or a removable center section with two smaller Quick-Change insert molds for complete application flexibility. Each frame's master ejector system is equipped with pillar post pads to support insert molds.

U Frame with Self-Contained Master Ejector System

ITEM NO.	C
10/12UF321MEP	2.500
10/14UF321MEP	2.500
10/16UF321MEP	2.500
12/14UF321MEP	2.750
12/16UF321MEP	2.750
12/18UF321MEP	2.750
13/16UF321MEP	2.750
13/18UF321MEP	2.750
14/16UF321MEP	2.750
14/18UF321MEP	2.750

Quick-Change Options Removable Center Sections

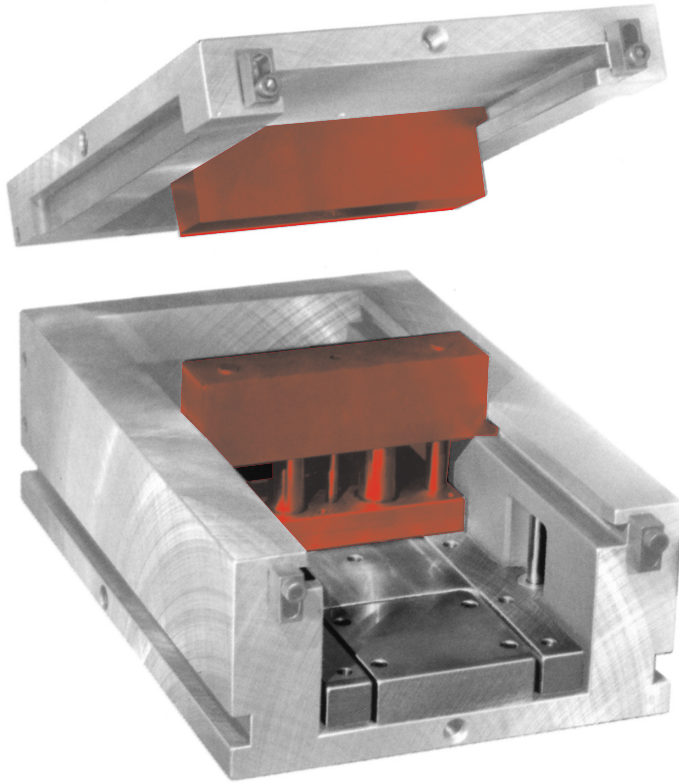

Removable Center Sections for U Frame with Master Ejector System

ITEM NO.	INSERT SIZE	A	B	C
10/12RCS-1	7.0 x 4.5	1.877	1.877	2.500
10/12RCS-2		1.877	2.377	2.500
10/12RCS-3		2.377	1.877	2.500
10/14RCS-1	7.0 x 5.5	1.877	1.877	2.500
10/14RCS-2		1.877	2.377	2.500
10/14RCS-3		2.377	1.877	2.500
10/16RCS-1	7.0 x 6.5	2.377	1.877	2.500
10/16RCS-2		1.877	2.377	2.500
10/16RCS-3		2.377	2.377	2.500
12/14RCS-1	8.0 x 5.5	1.877	1.877	2.750
12/14RCS-2		1.877	2.377	2.750
12/14RCS-3		2.377	1.877	2.750
12/16RCS-1	8.0 x 6.5	2.377	1.877	2.750
12/16RCS-2		1.877	2.377	2.750
12/16RCS-3		2.377	2.377	2.750
12/18RCS-1	8.0 x 7.5	2.377	1.877	2.750
12/18RCS-2		1.877	2.377	2.750
12/18RCS-3		2.377	2.377	2.750
13/16RCS-1	9.0 x 6.5	2.377	2.377	2.750
13/16RCS-2		2.377	2.877	2.750
13/16RCS-3		2.877	2.377	2.750
13/18RCS-1	9.0 x 7.5	2.377	2.377	2.750
13/18RCS-2		2.377	2.877	2.750
13/18RCS-3		2.877	3.377	2.750
14/16RCS-1	10.0 x 6.5	2.377	2.377	2.750
14/16RCS-2		2.377	2.877	2.750
14/16RCS-3		2.877	2.377	2.750
14/18RCS-1	10.0 x 7.5	2.377	2.377	2.750
14/18RCS-2		2.377	2.877	2.750
14/18RCS-3		2.877	2.377	2.750

Ordering Information for Removable Center Sections

- Item number and description (see table above right)
- First four digits of item number must match those of companion frame
- Specify "O" (orifice diameter)
- Runner size and configuration
- Center bar: Hardened steel
- Optional center bar to fit frame supplied with interlocking ejector plate rails available (quotation on request)

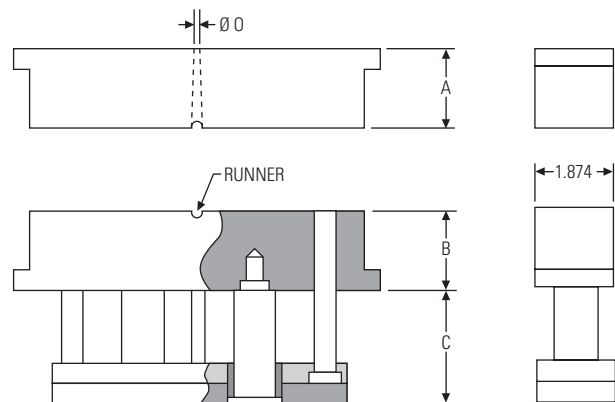

Quick-Change Options Removable Center Bar Assemblies

DME removable center bars are designed for U frames without integral master ejector plates. The center bar includes its own self-contained ejector plate system and is designed for production with two smaller Quick-Change insert molds.

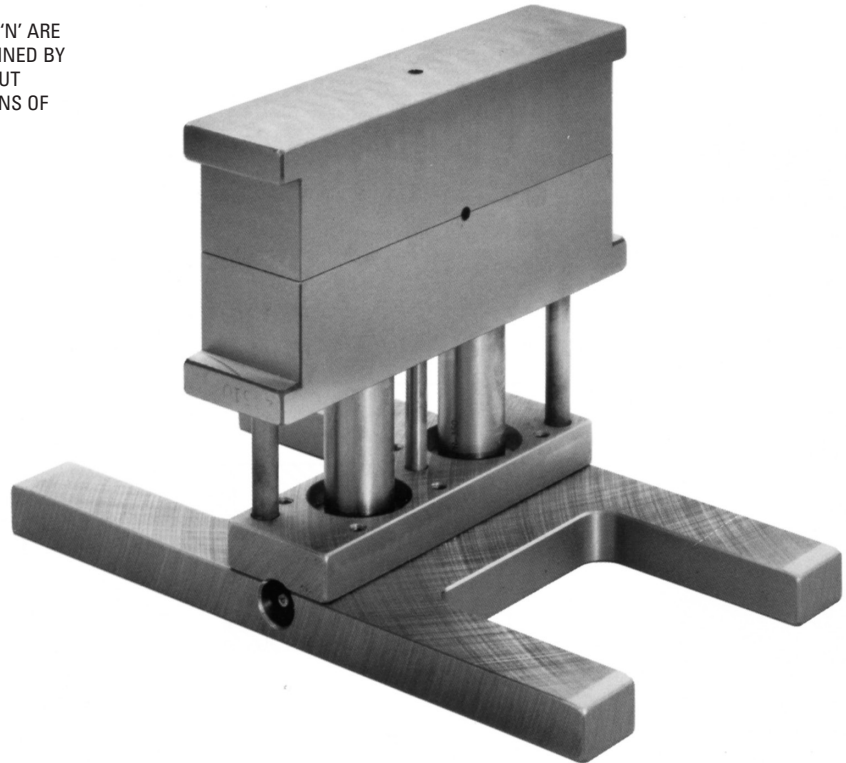
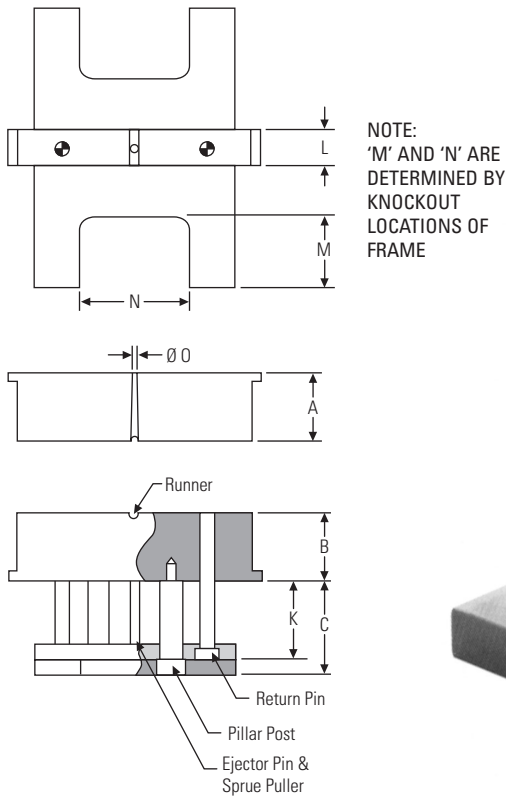

Removable Center Bar Assemblies for U Frame without Master Ejector System

ITEM NO.	INSERT	A	B	C	K	L
08/09 CB 231	5.0 x 3.5	1.877	1.377	2.625	2.265	1.000
08/09 CB 232		1.877	2.377	2.625	2.265	1.000
08/09 CB 233		2.377	1.877	2.625	2.265	1.000
08/10 CB 241	5.0 x 4.0	1.877	1.377	2.625	2.265	1.000
08/10 CB 242		1.877	2.377	2.625	2.265	1.000
08/10 CB 243		2.377	1.877	2.625	2.265	1.000
84/90 CB 251	6.5 x 3.5	1.877	1.877	2.625	2.146	1.000
84/90 CB 252		1.877	2.377	2.625	2.146	1.000
84/90 CB 253		2.377	1.877	2.625	2.146	1.000
10/12 CB 261	7.0 x 4.5	1.877	1.877	3.500	2.750	1.874
10/12 CB 262		1.877	2.377	3.500	2.750	1.874
10/12 CB 263		2.377	1.877	3.500	2.750	1.874
10/14 CB 271	7.0 x 5.5	1.877	1.877	3.500	2.750	1.874
10/14 CB 272		1.877	2.377	3.500	2.750	1.874
10/14 CB 273		2.377	1.877	3.500	2.750	1.874
11/11 CB 281	8.0 x 4.0	1.877	1.877	3.500	2.750	2.000
11/11 CB 282		1.877	2.377	3.500	2.750	2.000
11/11 CB 283		2.377	1.877	3.500	2.750	2.000
12/14 CB 291	8.0 x 5.5	1.877	1.877	4.000	3.000	1.874
12/14 CB 292		1.877	2.377	4.000	3.000	1.874
12/14 CB 293		2.377	1.877	4.000	3.000	1.874

All removable center bar ejector plates are supplied with cutout for pillar posts.

Ordering Information for Removable Center Bar Assemblies

- Item number and description (see table at left)
- First four digits of item number must match those of companion frame
- Specify "O" (orifice diameter)
- Runner size and configuration
- Center bar: Hardened steel



Quick-Change Options Center Bar Insert Molds

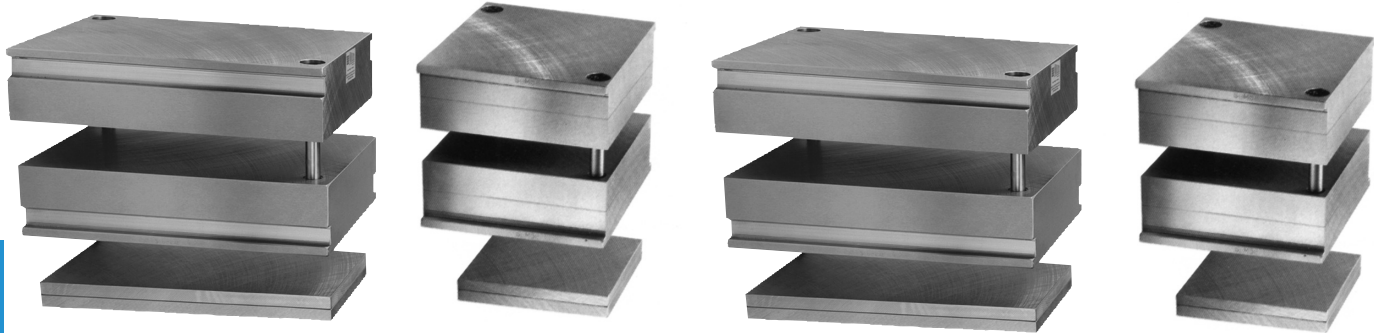

**Standard Solid:
5.0 x 4.0**

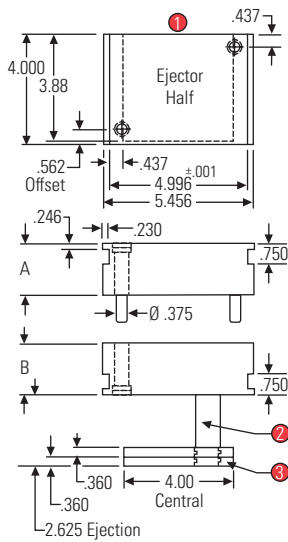

**Standard Laminated:
5.0 x 4.0**

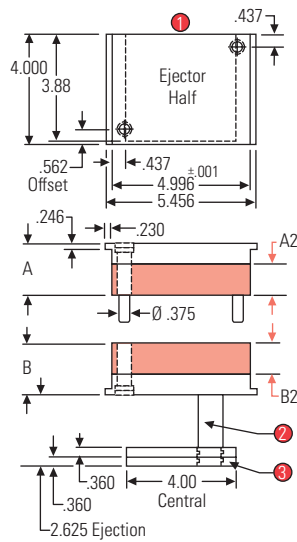

**Standard Solid:
6.5 x 3.5**

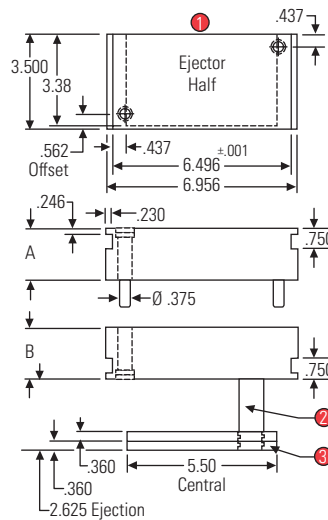

**Standard Laminated:
6.5 x 3.5**

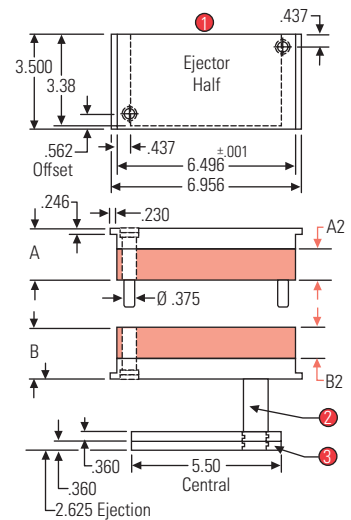

Standard Solid Construction

ITEM NO.	A	B
08/10SSB221	1.877	1.377
08/10SSB222	1.877	2.377
08/10SSB223	2.377	1.877

Standard Laminated Construction

ITEM NO.	A	A2	B2	B
08/10SLB281	1.877	0.877	0.877	1.377
08/10SLB282	1.877	0.877	1.377	2.377
08/10SLB283	2.377	1.377	0.877	1.877

Standard Solid Construction

ITEM NO.	A	B
84/90SSB221	1.877	1.877
84/90SSB222	1.877	2.377
84/90SSB223	2.377	1.877

Standard Laminated Construction

ITEM NO.	A	A2	B2	B
84/90SLB281	1.877	0.877	0.877	1.877
84/90SLB282	1.877	0.877	1.377	2.377
84/90SLB283	2.377	1.377	0.877	1.877

Standard Interchangeable Insert Molds

1. Frame clamps at this end of insert mold and ejector plates are flush with this end of insert.
2. Support post not supplied. Grind +.001 to +.002 higher than height of ejection.
3. Thicker plate optional (quotation on request).

Ordering Information for Center Bar Insert Molds

- Item number (see tables above)
- Steel grades: 1020, 4130 prehard, P-20 prehard and H-13; 420 stainless and other grades on request
- H-13 and other tool steel insert molds supplied .010 oversize on outside dimension, .010 to .013 oversize on thickness, and .025 to .035 undersize in pin and bushing holes for machining after required heat treating
- "A" & "B" dimensions supplied .004 to .007 oversize unless otherwise specified
- "A" and "B" dimensions for insert mold must match those of the removable center bar



Quick-Change Options Center Bar Insert Molds



Standard Solid:
8.0 x 4.0

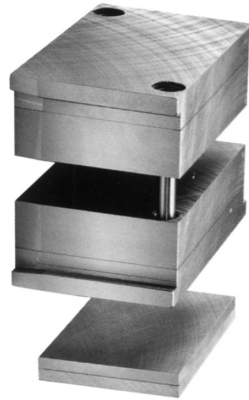

Standard Laminated:
8.0 x 4.0

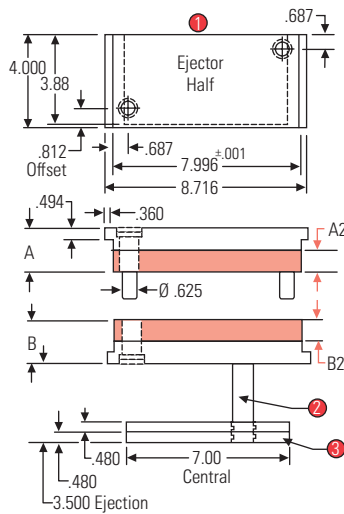
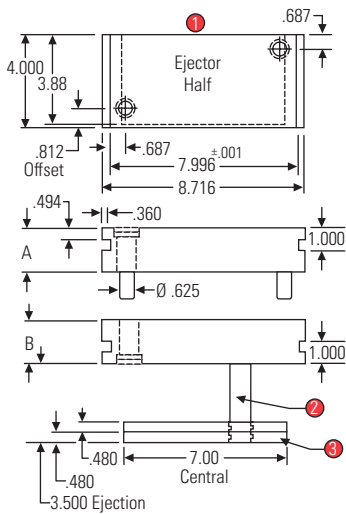

Standard Interchangeable Insert Molds

1. Frame clamps at this end of insert mold and ejector plates are flush with this end of insert.
2. Support post not supplied. Grind +.001 to +.002 higher than height of ejection.
3. Thicker plate optional (quotation on request).

Standard Solid Construction

ITEM NO.	A	B
11/11SSB221	1.877	1.877
11/11SSB222	1.877	2.377
11/11SSB223	2.377	1.877

Standard Laminated Construction

ITEM NO.	A	A2	B2	B
11/11SLB281	1.877	0.877	0.877	1.877
11/11SLB282	1.877	0.877	1.377	2.377
11/11SLB283	2.377	1.377	0.877	1.877

Ordering Information for Center Bar Insert Molds

- Item number (see tables above)
- Steel grades: 1020, 4130 prehard, P-20 prehard and H-13; 420 stainless and other grades on request
- H-13 and other tool steel insert molds supplied .010 oversize on outside dimension, .010 to .013 oversize on thickness, and .025 to .035 undersize in pin and bushing holes for machining after required heat treating
- "A" & "B" dimensions supplied .004 to .007 oversize unless otherwise specified
- "A" and "B" dimensions for insert mold must match those of the removable center bar

Quick-Change Options Stripper Plate & Three-Plate Insert Molds

DME manufactures special stripper plate and three-plate insert molds to customer specifications. Quotation on request.

Stripper Plate
Insert Mold

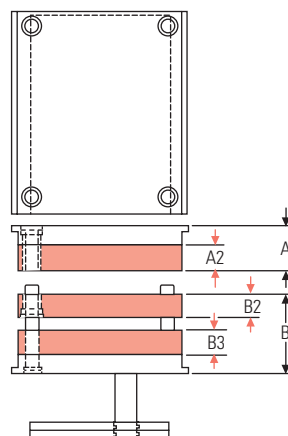

A & B dimensions are overall stack height of each half in closed position.

Three-Plate
Insert Mold

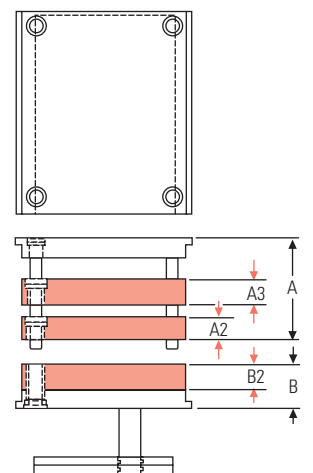
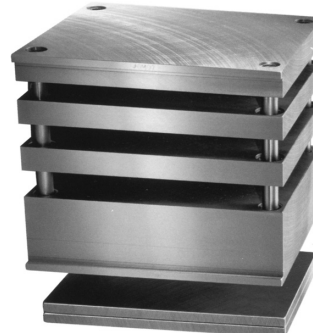

Quick-Change Options 84/90 UF Extended Clamp Bar Sets

DME extended clamp bar sets bolt to 84/90 U frames for clamping to machine platens requiring mold clamps.

NOTE: If you are using the 84/90 UF Extended Clamp Bar Sets, please also reference the 94/90 UF 321 MUD® Quick-Change Frame which has standard clamp slots and accepts all the 84/90 UF 321 Quick-Change Inserts.

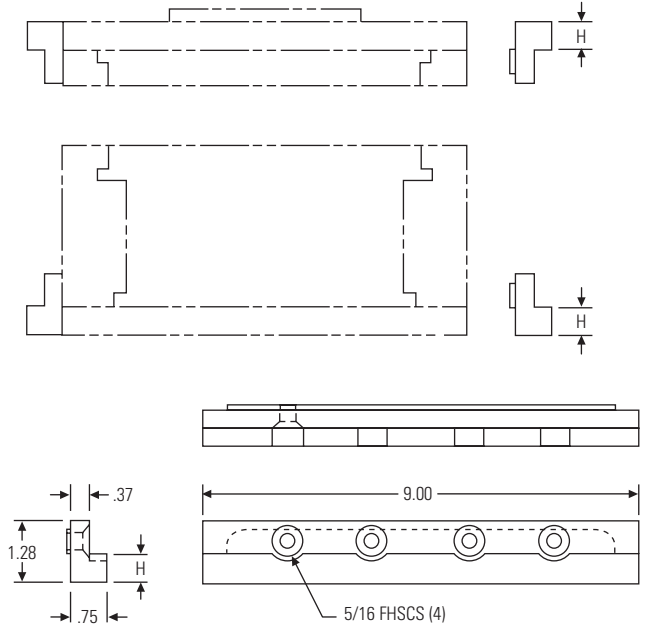

Extended Clamp Bar Sets

ITEM NO.	H
84/90ECB-6	.60
84/90ECB-9	.90

Sets of 4 supplied.

Quick-Change Options 08/09 and 84/90 UF Spacer Plate Sets

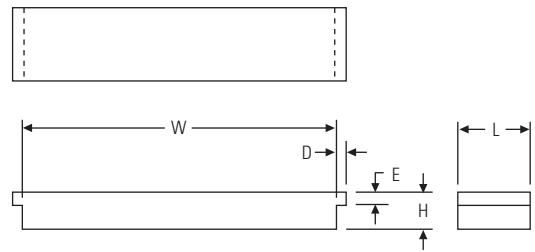
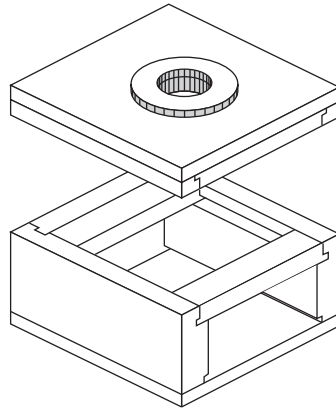

DME spacer plate sets are installed to center shorter insert molds in frames designed for longer insert molds. Set includes four spacer plates (two 'A' and two 'B'). Quotation for other sizes on request.

Spacer Plate Sets

ITEM NO.	INSERT	W	H	L	D	E
08/09SP	5.0 x 3.5	4.996	0.750	2.250	0.230	0.246
84/90SP	6.5 x 3.5	6.496	0.750	2.250	0.230	0.246

MUD® Quick-Change Options for Mold Frames & Inserts | Extended Clamp Bar and Spacer Plate Sets



Quick-Change Options 84/90 UF Adapter Assemblies

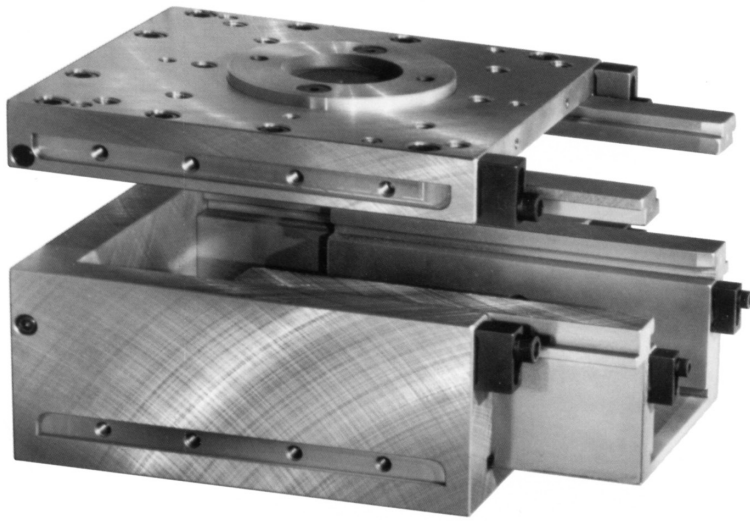

84/90 UF 301 frame with 07/07 adapter assembly partially installed.

07/07 Adapter Assembly

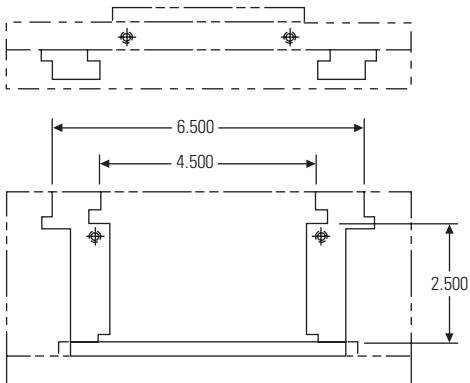

ITEM NO.
84/90UF 7-7

08/09 Adapter Assembly

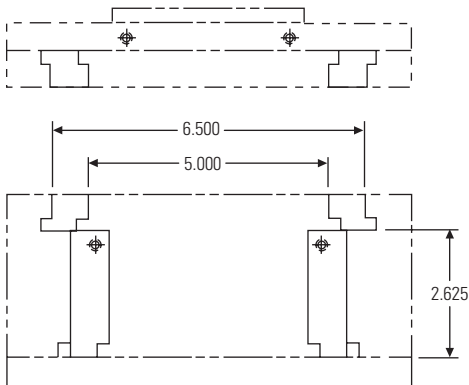

ITEM NO.
84/90UF 8-9

DME adapter rail assemblies permit 84/90 UF Quick-Change frames to accept insert molds from 07/07 UF (previously 06/07 FAU) frames (left) or 08/09 UF frames (right).

MUD® Quick-Change Options for Mold Frames & Inserts | 84/90 UF Adapter Assemblies



Quick-Change Options 05/05 UF Adapter Plates

MUD® Quick-Change Options for Mold Frames & Inserts | 05/05 UF Adapter Plates

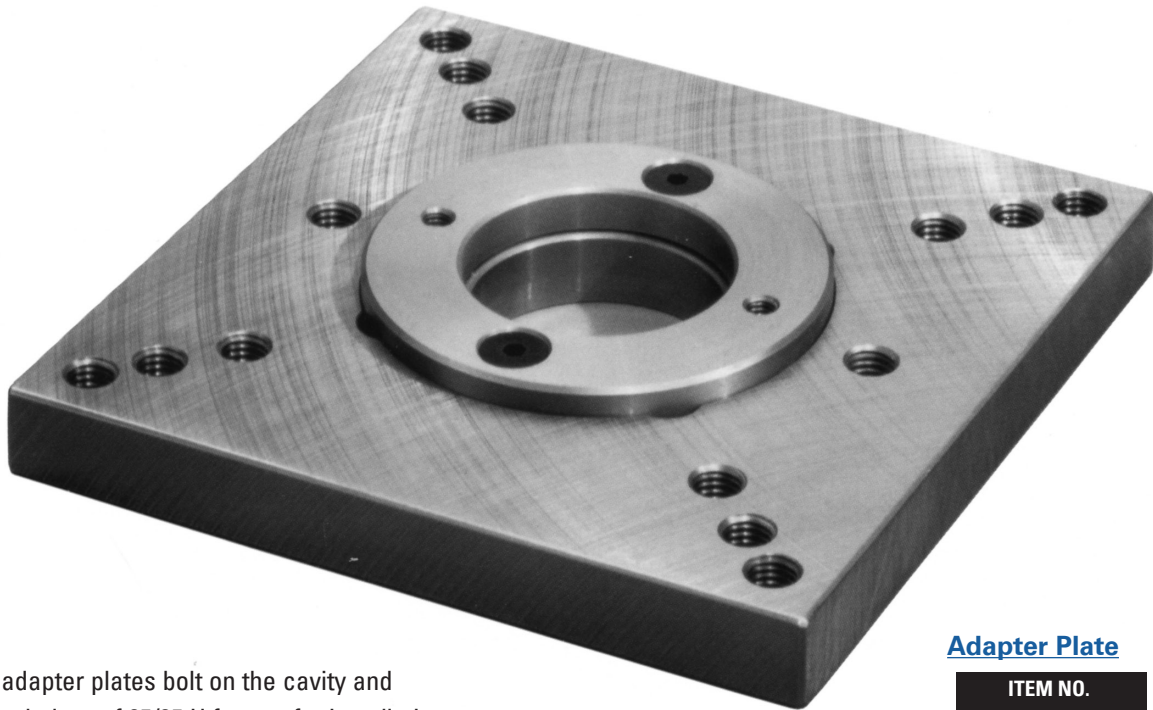

DME adapter plates bolt on the cavity and ejector halves of 05/05 U frames for installation on most molding machines with standard mounting screws or clamps.

Adapter Plate

ITEM NO.
05/05UFAP

Set of 2 supplied.

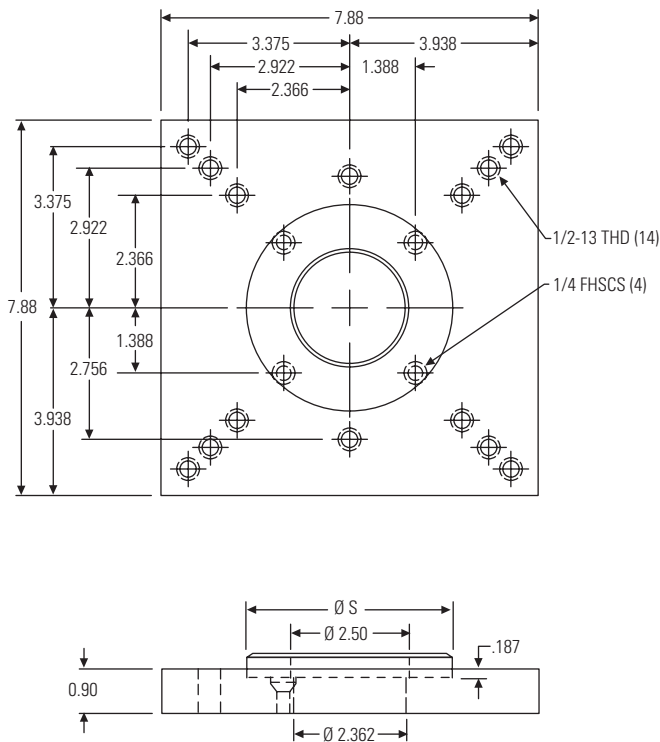

Spacer Plate Sets

The addition of the spacer plate set illustrated below permits the 05/05 UF 321 frame to accept 3.25 x 3.15 insert molds.

ITEM NO.
05/05SP

Item number includes one plate and four spacers

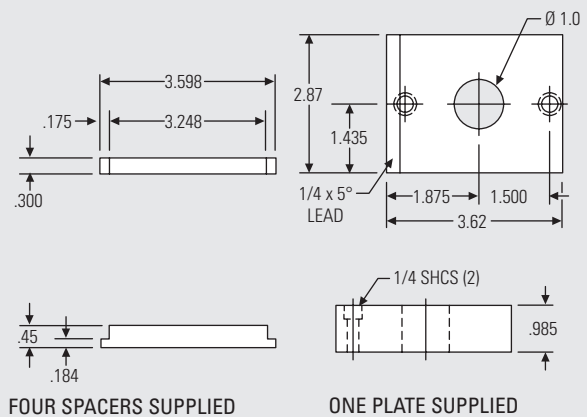

FOUR SPACERS SUPPLIED

ONE PLATE SUPPLIED



Quick-Change Options 08/09 and 84/90 UF Bolster Plates

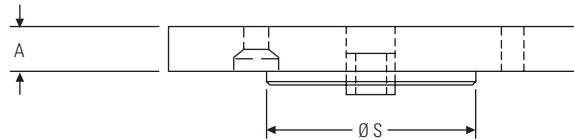
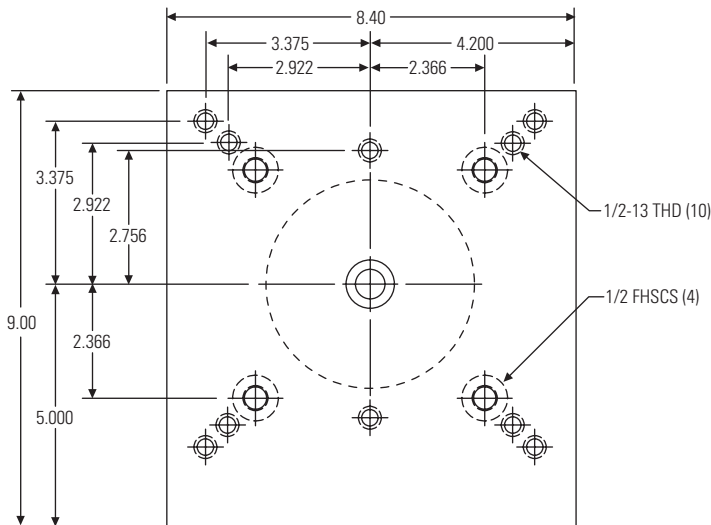
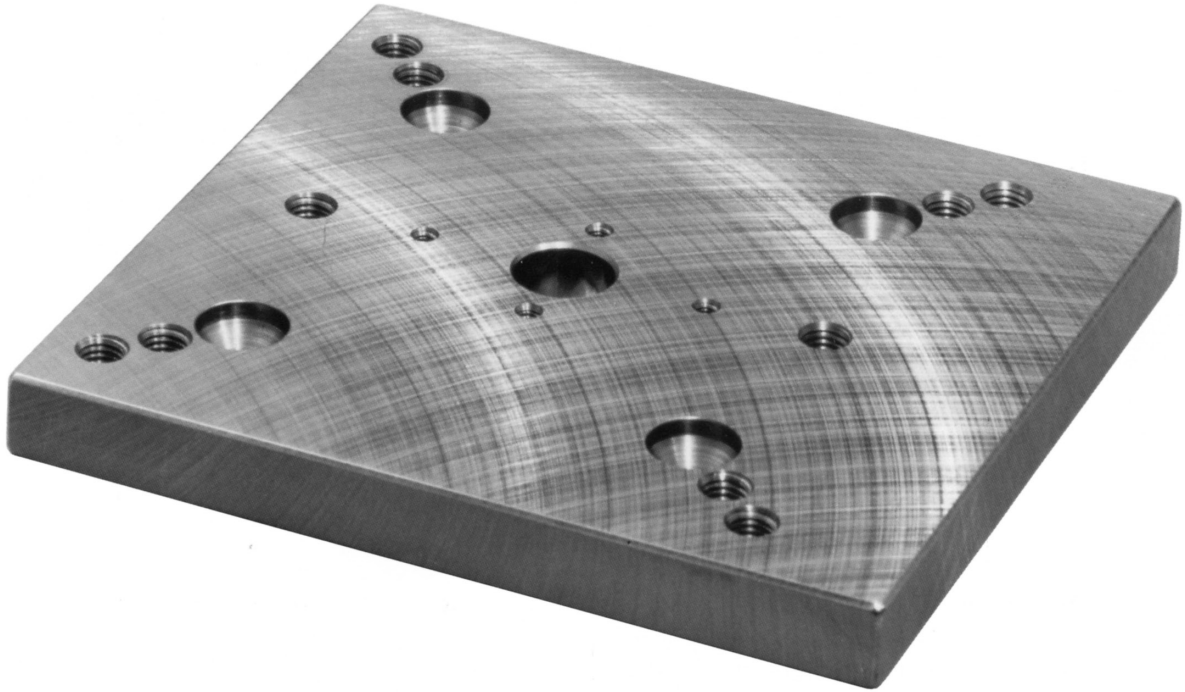

DME bolster plates install on the ejector half of 08/09 and 84/90 U frames to meet the minimum shut height requirements.

Bolster Plates

ITEM NO.	A	S DIA
BBP001	0.900	2.358
BBP002	0.900	4.330
BBP003	2.875	4.916
BBP004	0.900	none
BBP005	0.900	2.358
BBP006	0.900	2.358
BBP007	0.900	4.330
BBP008	2.875	4.916
BBP009	2.875	4.916

MUD® Quick-Change Options for Mold Frames & Inserts | 08/09 and 84/90 UF Bolster Plates



Quick-Change Options Special Adapter Plates

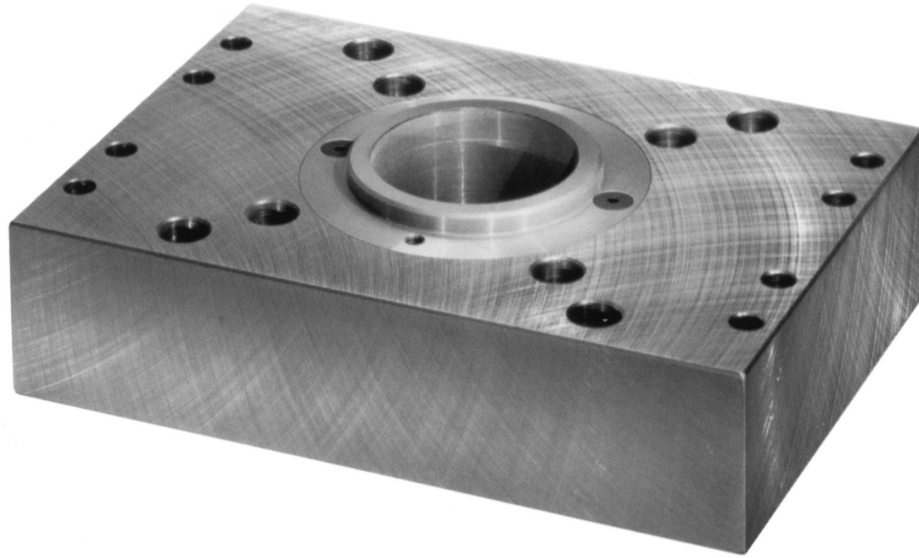

MUD® Quick-Change Options for Mold Frames & Inserts | Special Adapter Plates

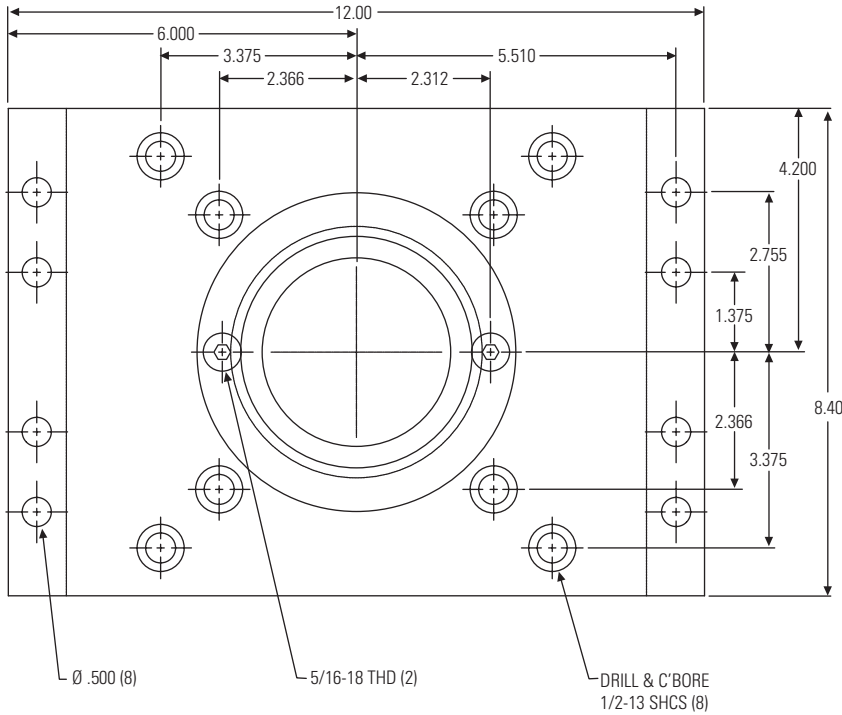

Special Adapter Plates

DME adapter plates bolt on the cavity and ejector halves of 08/09 and 84/90 U frames to meet minimum shut height requirements.

ITEM NO.	A DIM	B DIM	S
APA101	0.875	0.875	3.928
APA102	0.875	2.875	3.990
APA103	0.875	2.875	4.916

Check machine for specific locating ring size (specify "S" size).

PLATE THICKNESS	X
0.875	0.500
2.875	0.660

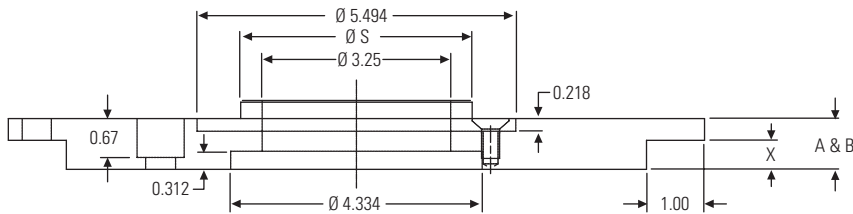

TWO PLATES REQUIRED (CAVITY HALF AND EJECTOR HALF)



Quick-Change Options High Temperature Insulator Sheets

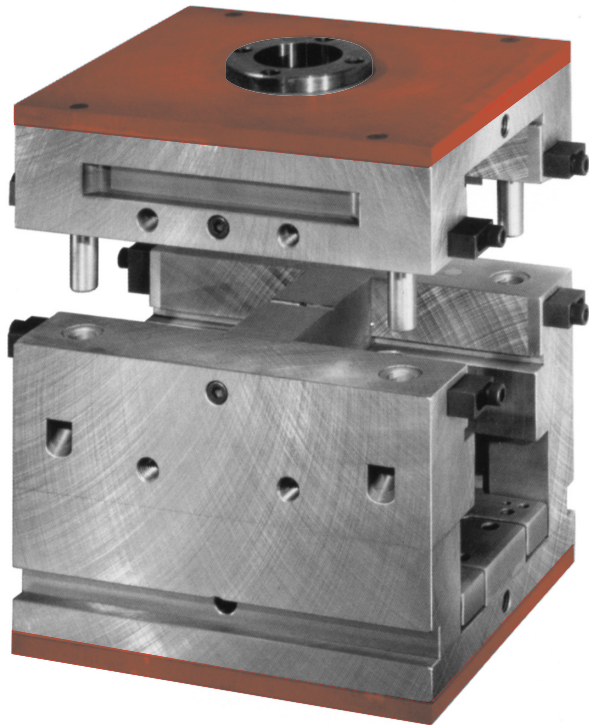

Insulator Sheets

MUD® insulator sheets are installed between the top of the Quick-Change frame and the stationary platen, and between the bottom of the frame and the movable platen. The thermal insulating properties of these asbestos-free sheets inhibit heat transfer between the platens and the frame. This saves energy and extends both insert mold and machine life. Compression molded in glass-reinforced polymer composite, the sheets have more compressive strength than either asbestos or mica materials. The sheets' dimensional stability is excellent and they are supplied micro-finished top and bottom, parallel within $\pm .002''$. Quotation on request.

ENERGY SAVINGS

1/4 THICK = 27,508 BTU/hr

1/2 THICK = 31,004 BTU/hr

Quick-Change Options Additional Ear Slots

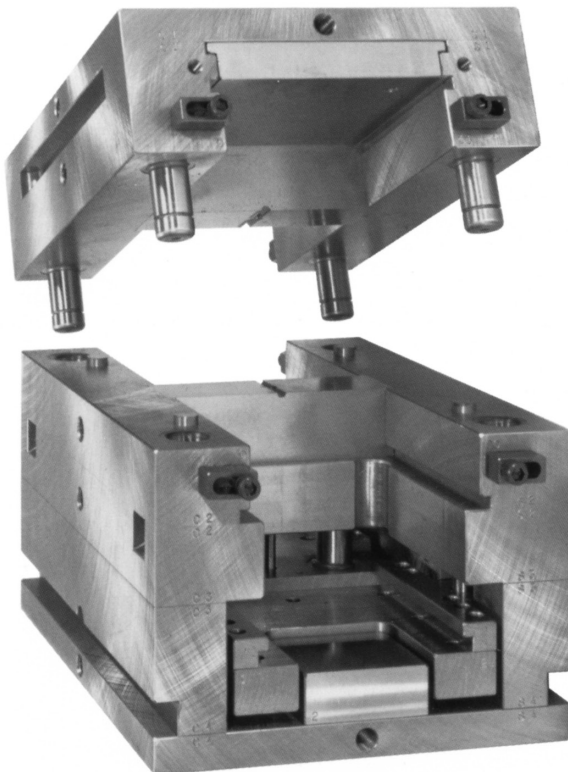

H frames and Double H frames can be ordered with a second pair of ear slots machined in the A half. This second pair of ear slots permits insert molds of two different thicknesses to be interchanged in this half of the frame. The second size insert mold is one inch thinner and is lighter and less costly. Quotation on request.

Quick-Change Options Insert Mold Loading Rails

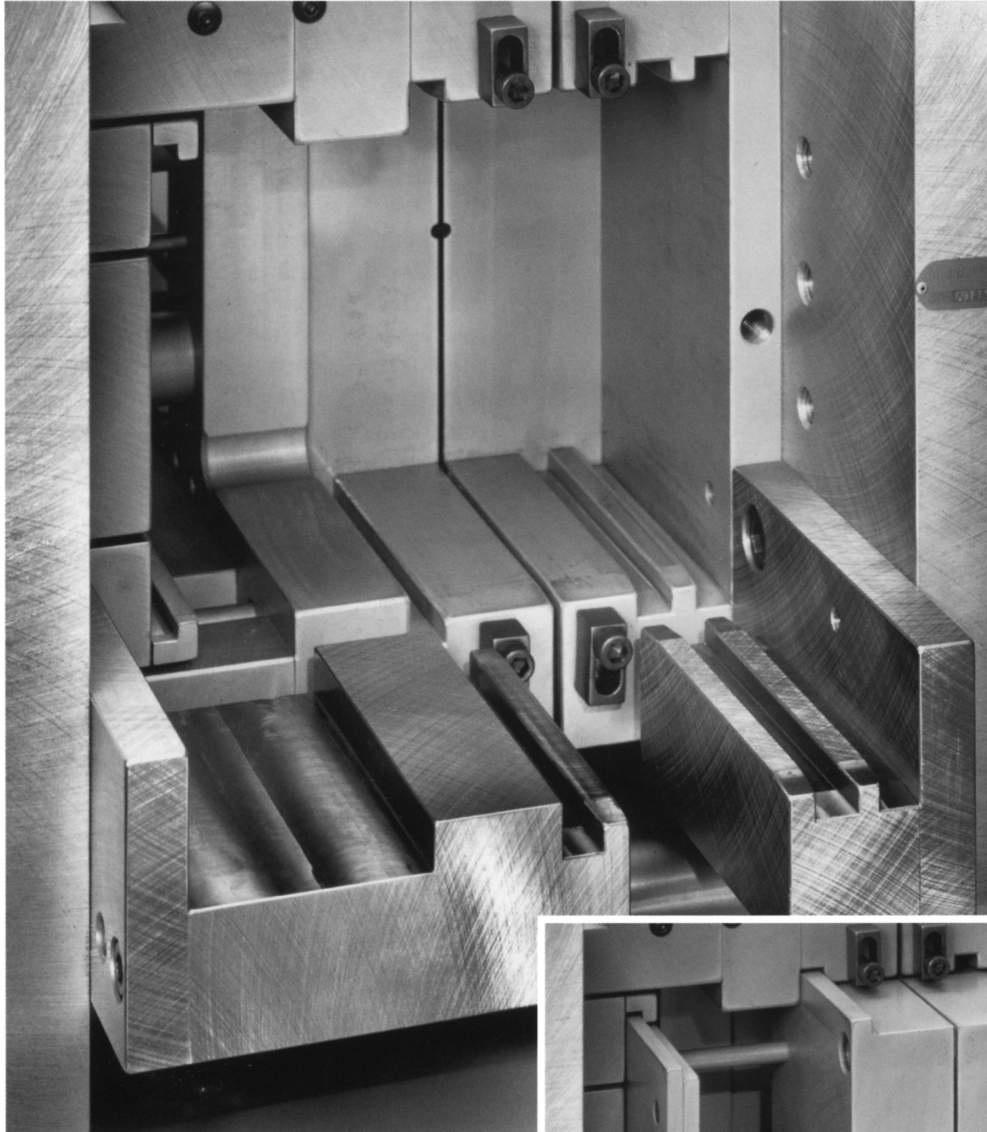

Loading rails are designed to further simplify the production changeovers of larger companion insert molds in H frames and Double H frames. These optional rails are attached to molding machine platens and are produced for specific frame models. Quotation on request.

Photograph at right illustrates companion insert mold partially installed in Quick-Change frame equipped with loading rails.

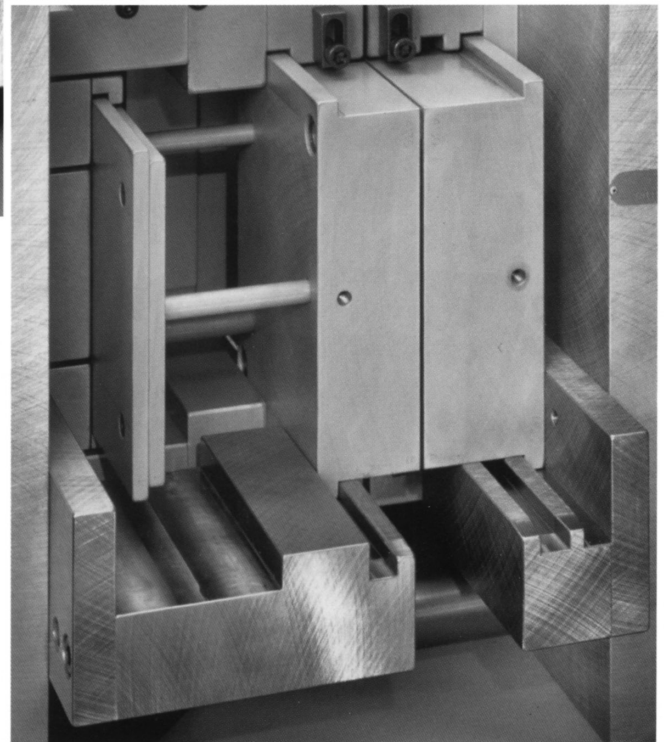

Quick-Change Options Mold Tooling Protection with Coating Options

Combat high tooling and production costs with Coating by MUD®

Precision-made plastics tools by Master Unit Die offer quick-change versatility that ensures a dramatic reduction in tooling costs. Under normal working conditions, this tooling is subjected to atmospheric and operating stress that, over time, causes deterioration that leads to maintenance and replacement costs. The two basic destructive forces that age tooling are wear and corrosion. TDC (Thin Dense Chromium) Coating or Electroless Nickel Plating by MUD® assists in dramatically reducing wear and corrosion to minimize maintenance and replacement costs.

The surface hardness, low coefficient of friction, and anti-corrosive properties of these coatings contribute to the protection and longevity of your tooling. The result is a tool that retains a “like new” appearance, promoting “new-tool handling” by employees.

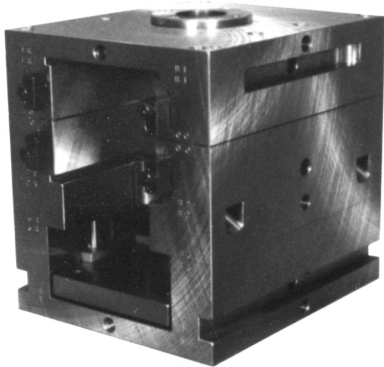

Wish you could maintain that new tool appearance?

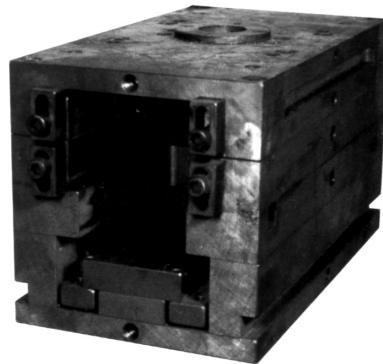

Unfortunately, rust and corrosion cause old tool appearance over time.

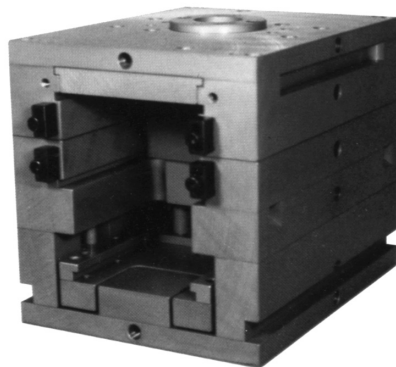

Protect your investment with MUD®'s coating treatments.

Contact DME Customer Service for pricing.

U.S. 800-626-6653 • dme.net • store.dme.net
Canada 800-387-6600 • Mexico 52-442-713-5666

Quick-Change Options Two-Color, Two-Material Molding

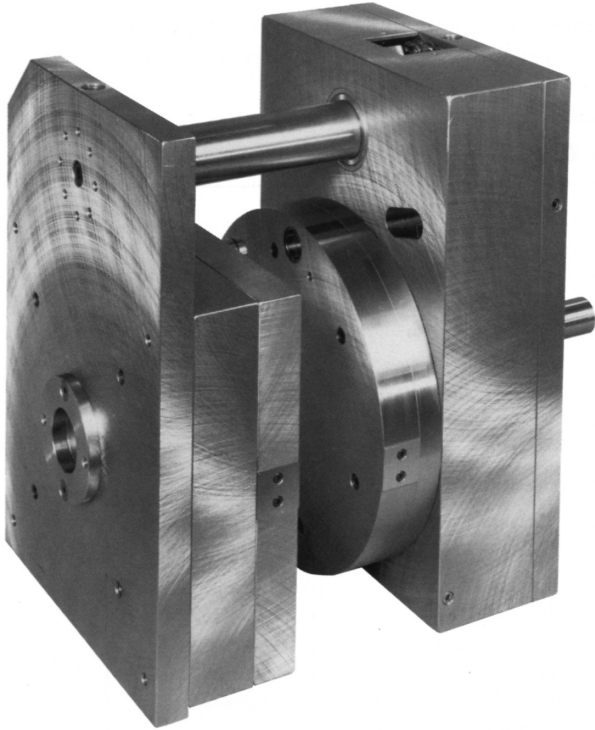

Common Core



Stripper Plate

Automatic two-color, two-material injection molding system available

MUD® two-color/two-material mold frames permit automatic molding of two-color or two-material parts. These frames are specifically designed for all two-color and two-material equipment currently available. Both core and cavity plates can be changed without removing the frame from the machine.

Other features include water cooling for the A and B sections except the indexing component. Automatic positive 180° indexing is mechanically rotated by either the clamp opening or closing stroke of the machine. Pneumatic or hydraulic power can be utilized. This approach to two-color, two-material molding offers smooth and efficient operation that's completely automatic.

NOTE: MUD® two-color/two-material mold frames are quoted items based on customer specifications.



Quick-Change Options DME Standard Heat Pipes

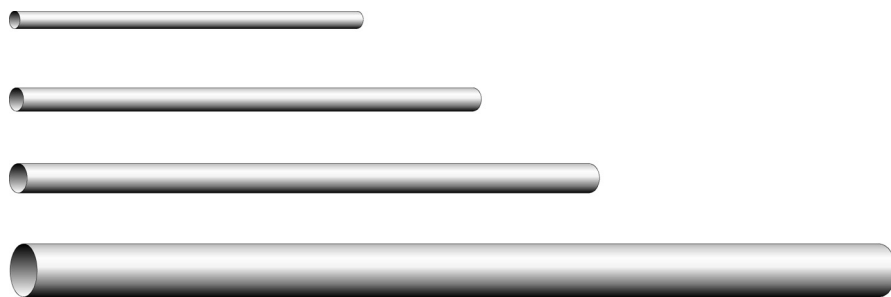

- Reduce cycle time
- Improve part quality
- Simplify mold and die design
- Reduce operating and maintenance costs
- Upgrade existing molds and dies
- Salvage damaged molds and dies

Selecting the Right Size, Shape and Temperature Range

The standard diameters, lengths and temperature ranges of TPL, TPH and TPDC Series Heat Pipes will satisfy most applications.

NOTE: Heat Pipes cannot be used as ejector pins and parts cannot be molded or cast against them. Also, Heat Pipes cannot be cut, machined, bent or plated. If a special size is required, contact DME to discuss your application.

TPL, TPH AND TPDC SERIES	TOLERANCES
Diameter (O.D.)	±.004
Length	±.020

TPL and TPH Heat Pipes for Injection Molding

For low-temperature Heat Pipes (40°-200°F) use TPL (color-coded BLACK) as a prefix in front of item number in the table below. For high-temperature Heat Pipes (150°-400°F) use TPH (color-coded WHITE) as the prefix.

LENGTH (INCHES)	TPL & TPH DIAMETER & ITEM NUMBER					
	1/8	3/16	1/4	5/16	3/8	1/2
3	4300	6300	8300	10300	12300	16300
4	4400	6400	8400	10400	12400	16400
5	4500	6500	8500	—	—	—
6	4600	6600	8600	10600	12600	16600
7	4700	6700	8700	—	—	—
8	4800	6800	8800	10800	12800	16800
10	—	—	—	101000	121000	161000
12	—	—	—	—	—	161200

Silver Heat Transfer Compound* for TPL and TPH Series Heat Pipes (Item No. HTC06S)

Contains micronic particles of silver to provide a thermal resistance of 4.75°Cin/watt. The compound is supplied in a 5cc plastic syringe. (DME recommends the Silver Heat Transfer Compound because it has eight times lower thermal resistance than the copper equivalent.)

Copper Heat Transfer Compound* for TPL, TPH and TPDC Series Heat Pipes (Item No. HTC30C)

Contains micronic particles of copper to provide a thermal resistance of 38°Cin/watt. The compound is supplied in a 5cc plastic syringe.

* For .125" diameter Heat Pipes, do not use applicator tube supplied with Heat Transfer Compound. Apply desired amount of compound directly into core hole.

Tamp Ring Sets

Each set includes 32 silver alloy tamp rings (enough for installing 16 Heat Pipes) and one hollow tamping tube.

ITEM NO.	TARS04	TARS06	TARS08	TARS10	TARS12	TARS16
Ring I.D.	1/8	3/16	1/4	5/16	3/8	1/2



Quick-Change Options Hot Runner-Infused Quick-Change Systems

Increase Productivity and Reduce Molding Costs With Hot Runner-Infused Quick-Change Systems

Now the production efficiencies of hot runner molding can be further enhanced when combined with a Master Unit Die (MUD®) Quick-Change Frame. An unlimited number of different parts can be produced with this industry-leading combination of hot runners within a quick-change system because only the MUD® Companion Insert Mold is swapped out. The MUD® Frame/Hot Runner System remains in the mold.

Combining DME Hot Runners with MUD® Quick-Change Systems provides many advantages to virtually any injection molding operation, including:

- Enables molders to use the same DME Hot Runner System with many different cavity and core configurations with MUD® Companion Insert Molds
- Quickens production changeovers, often in as little as five minutes
- Provides cost justification for the Hot Runner System and/or the MUD® Quick-Change System for multiple tooling projects
- Simplifies design with the use of the MUD® Quick-Change Straps

Contact your [DME representative](#) or call us today to find out more about how the combination of a DME Hot Runner System and the MUD® Quick-Change System will not only substantially increase your production efficiency but significantly reduce your molding costs. Many companies incorporate the DME hot runner/quick-change combo into their Lean initiatives.

MUD® Quick-Change Options for Mold Frames & Inserts | Hot Runner-Infused Quick-Change Systems

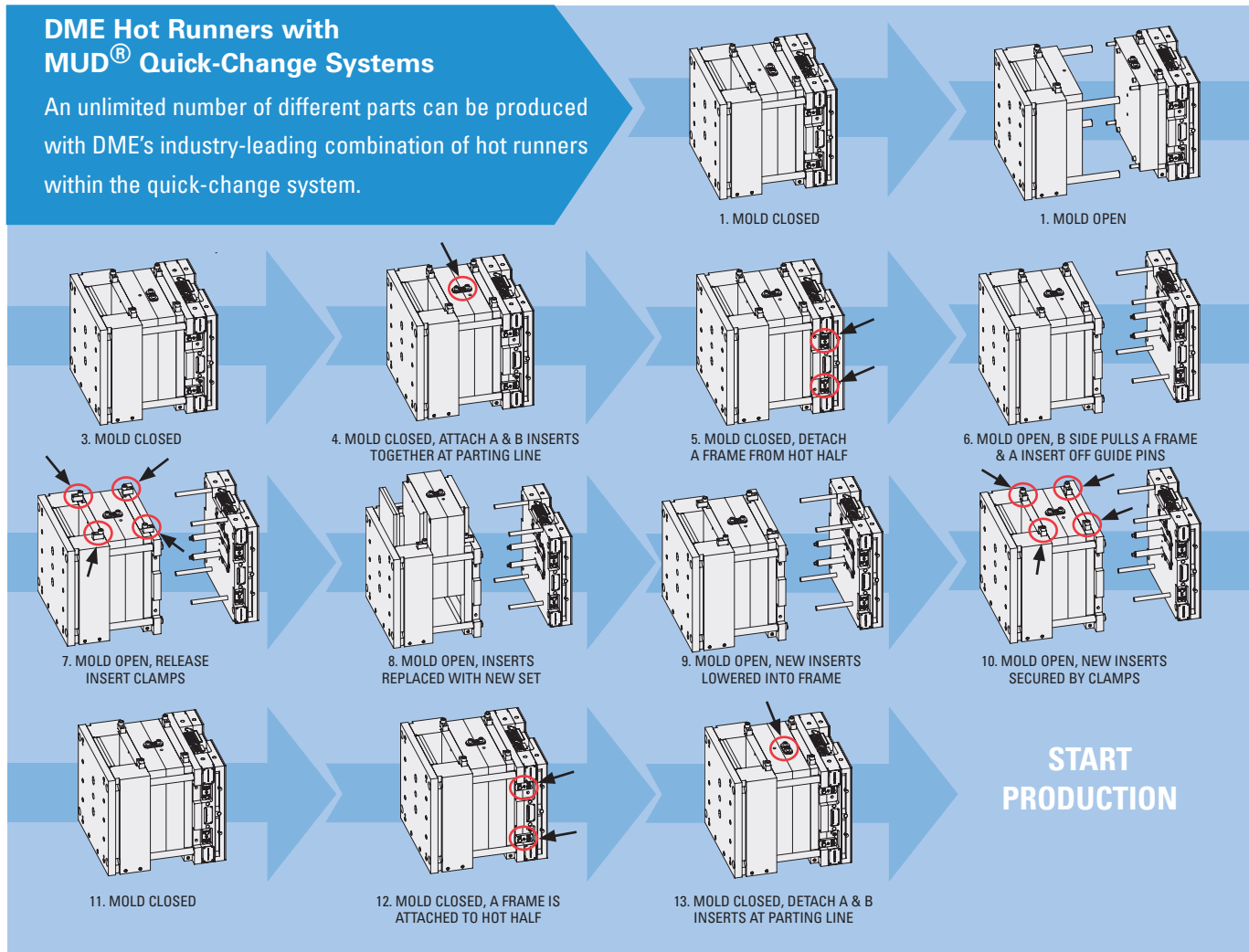

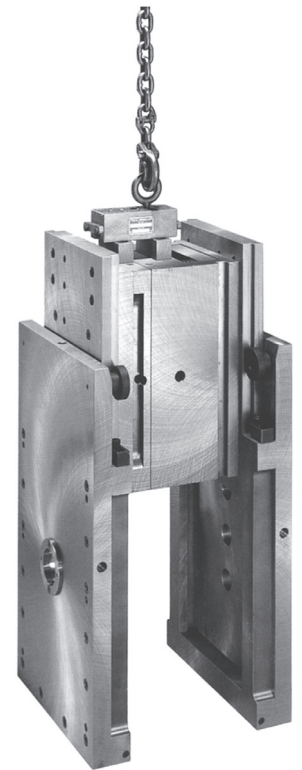
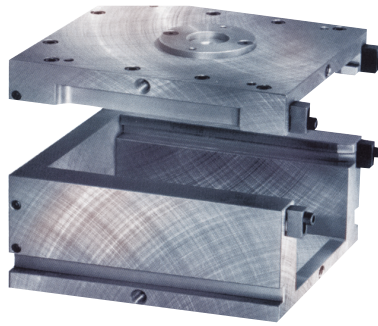
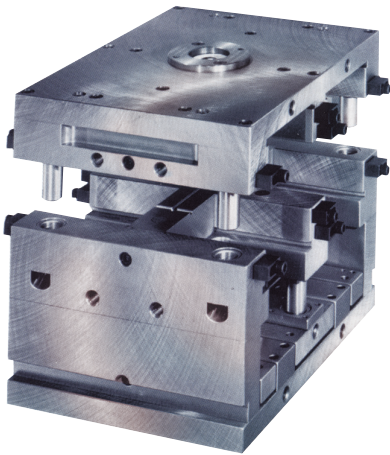
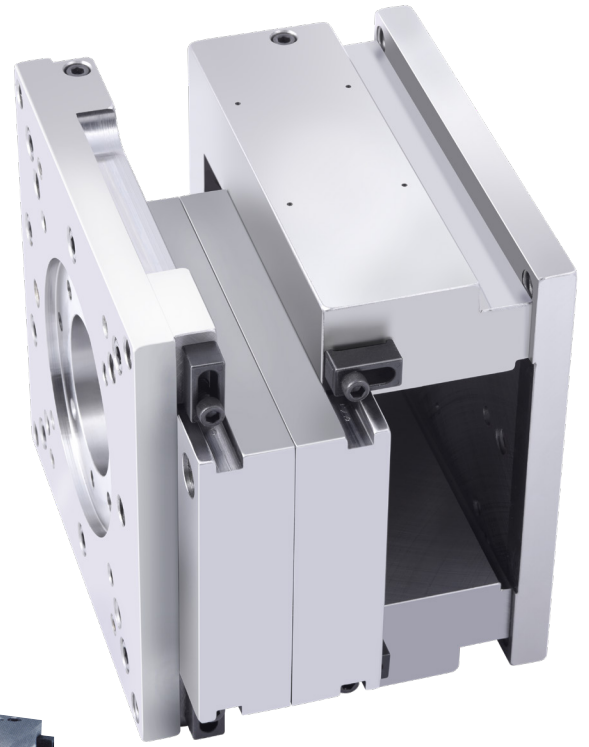

MUD MASTER
UNIT DIE

MUD® QUICK CHANGE SYSTEMS

DME Company USA

29111 Stephenson Highway
Madison Heights, MI 48071
800-626-6653 (toll-free)
248-398-6000
888-808-4363 (toll-free fax)
dme@dme.net

DME Canada

A - 99 First Gulf BLVD
Brampton, ON
L6W 4T8 Canada
800-387-6600 (toll-free)
905-677-6370
800-461-9985 (toll-free fax)
dme_canada@dme.net

DME Mexico

Circuito el Marques Norte
No. 55
Parque Industrial El Marques
El Marques, Queretaro,
CP 76246
52.442.713.5666
dme_mexico@dme.net

eSTORE
store.dme.net

DME®

2022 DME All rights reserved. Printed in the U.S.A.