



DME

HOT RUNNER & CONTROL SYSTEMS

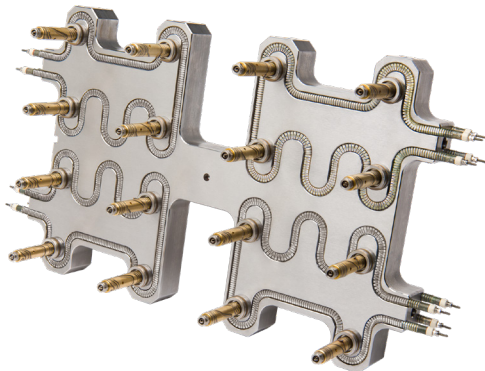

Table of Contents

Hot Runner Systems

Customer Commitment.....	4
Terms and Conditions of Sale.....	5
Sales and Ordering Information.....	6
Hot Runner Warranty.....	7
Hot Runner Systems Overview.....	8-9
Custom Applications Engineered Hot Runner Systems	
Hot Runner Selection Guide.....	11
Standard Global Manifold and Components.....	13
Plastic Materials, Specs/Bushing Selection.....	13-14
Hot Runner Quote Request Form.....	15
DME Hot Runner Technology.....	18

Hot Runner Systems

StellarOne Hot Runner Systems.....	20-27
------------------------------------	-------

Thermal Gate Hot Runner Systems

Stellar Micromolding.....	29-32
---------------------------	-------

Standard Pre-Engineered Hot Runner Systems

The Hot One Technology.....	34-52
Meteor Hot Runner.....	51-60

Hot Sprue Bushings

D-MAX.....	64-69
Gate-Mate.....	71-77
Straight Shot®.....	79-88
>High-Performance.....	79-80
>S-Series.....	81
>E-Series.....	82-83
>ER-Series.....	84-85
>T-Series.....	86
>TR-Series.....	87
>Replacement Parts.....	88
Integrally Heated Sprue Bushings.....	89-94

Hot Runner Services

Moldflow.....	96-97
Moldflow Quote Request Form.....	98
Hot Runner Service Center.....	99-100

Obsolete System Replacement Parts

Gate-Mate.....	102-103
Cool One.....	104-111

Modular Components Deliver High Performance.....112

Temperature Control Systems**SS TSP & TSP Plus****Smart Series®**

ITSP Plus (Touch Screen Panel.....)	114-118
Typical System Configurations.....	124
Single Zone Controllers.....	125-127
2-zone Controllers.....	127
Single & 2-zone Accessories.....	128-129

Smart Series 15 AMP Mainframe

Configurations.....	131-132
Floor Stand.....	135
Step-Down Transformer Kits.....	135
Blank Panels, Fuses & Crimp Connectors.....	135
Mainframe Connector Wiring.....	136-138
Mold Power & Thermocouple Cables.....	139
Mold Power Input Connectors.....	140
Mold Thermocouple Connectors.....	141
Mold Connector Pocket Layouts.....	142-143
Pre-wired Combination Terminal Mounting Boxes....	144
Terminal Mounting Boxes.....	145
SSM Modules.....	146-147
TSM Modules.....	148-149
TAS Temperature Alarm/System Modules.....	150-151
Replacement Parts.....	152-154
Input Wiring Diagram.....	155-157
Alternate Cable Configurations.....	158-161
Smart Series Me Temperature Controllers.....	162-163
Smart Series M2+ Temperature Controllers.....	164-166
Smart Series Mt2 Temperature Controllers.....	167-168

Valve Gate Controller Products & Solutions

SVG Valve Gate Controllers.....	170-173
Valve Gate Cables.....	174
VCAP Air Valve Assemblies.....	174
Single Zone Timer.....	169
Technical Support.....	176-177

Index

Alternate Cable Configuration.....	159	Obsolete Hot Runner Replacement Parts.....	101
Alternate Cable Wiring Diagram.....	160	Cool One & Micro Cool One.....	104
Blank Panels, Fuses & Crimp Connectors.....	135	Gate-Mate Nozzles.....	102
Bushing Selection.....	14	Gate Shell Insulators.....	103
Cartridge Heaters.....	47	Replacement Parts (Temp Control)	152
Control Systems.....	114	Sales and Ordering Information	6
D-MAX High Performance Hot Sprue Bushings.....	63	Selection Guide, Hot Runner Technology.....	10
Digital Current/Voltage Monitor.....	134	Single & 2-Zone Controller Accessories	125-130
Flexible Tubular Heaters	41	Single Zone Controllers	125
Floor Stand (Temp Control)	135	Single Zone High Power Controller & Accessories.....	130
Gate-Mate Hot Sprue Bushings.....	71	Single Zone Timer	169
Global Manifolds	13	Smart Series Me Temperature Controllers.....	162
Hot One Components & Accessories	35	Smart Series M2+ Temperature Controllers.....	162
Hot One Hot Runner Technology – Overview.....	18	Smart Series Mt2 Temperature Controllers.....	167
Hot Runner Modular Components.....	112	SSM15 AMP Mainframe Modules.....	146
Hot Runner Quote Request Form	15	Stellar Micromolding Hot Runner Systems.....	28
Hot Runner Services	96	StellarONE Hot Runner System.....	20-27
Hot Runner Selection Guide	10	Step-Down Transformer Kit.....	135
Hot Runner Warranty.....	7	Straight Shot™ Hot Sprue Bushings	78
Hot Sprue Bushings, D-MAX High Performance.....	64	TAS Temperature Alarm/System Modules.....	150
Hot Sprue Bushings, E-Series Straight Shot®.....	82	Technical Support Data (Temp Control).....	170
Hot Sprue Bushings, ER-Series Straight Shot®.....	84	Terminal Mounting Boxes.....	145, 161
Hot Sprue Bushings, High-Performance.....	79	Terms and Conditions of Sale.....	5
Hot Sprue Bushings, Integrally Heated	89	Thermocouple Cables	139
Hot Sprue Bushings, Straight Shot® Replacement	88	Thermocouple Input Connectors.....	140
Hot Sprue Bushings, S-Series Straight Shot.®.....	81	TSM Modules	148
Hot Sprue Bushings, Straight Shot.®.....	78	TSP Plus Temperature Controllers.....	118
Hot Sprue Bushings, T-Series Straight Shot.®.....	86	Tubular Heaters, Flexible	41
Hot Sprue Bushings, TR-Series Straight Shot.®.....	87	Two Zone (2-Zone) Temperature Controllers.....	127
Input Power Wiring Diagrams.....	155	Typical System Configuration (Temp Control)	124
Integrally Heated Hot Sprue Bushings	89	VCAP Air Valve Accessories.....	168
Mainframe Connector Wiring.....	136	Valve Gate Controls	164
Meteor Hot Runner Systems	53	Valve Gate Single Zone Timer.....	169
Moldflow™ Services.....	96	Warranty Information.....	7
Mold Connector Pocket Layouts.....	142		
Mold Filling/Mold Cooling Analysis Form	98		
Mold Power Cables.....	139		
Mold Power Input Connectors.....	140		
Mold Thermocouple Connectors.....	141		
Pre-Wired Combination Terminal Mounting Boxes.....	144		
Plastic Materials and Specifications.....	13		

Customer Commitment

Application Engineering

Is there a hot runner application on your wish list that you don't see here? DME can help. Our design and applications engineering group consists of professional engineers and experienced designers. Once you provide the information necessary for proper application design and analysis, the DME applications engineering team will go to work diligently analyzing, designing and manufacturing a hot runner system that will best suit your needs and requirements.

Technical Service

DME is proud to say that it is an industry model for technical service coverage and response. The DME technical service department covers the entire United States and Canada, with additional service representatives in Europe, Asia and throughout the world. Because DME knows you need assistance starting, operating, and maintaining hot runner systems it has made a great effort to strategically staff a Technical Service Department that is responsible for the success of DME's molding systems.

Field Sales and **Customer Service**

When you need a knowledgeable person to help you order parts and components, DME has you covered. Our direct field sales force puts a local sales representative in your area. One who understands your business and can offer valuable assistance in helping you select the molding system best suited to your application and your budget. In addition, DME provides a customer service department that has been extensively trained on all of DME's products and systems, making it easier for you to order and have your questions answered. We can provide you price and delivery information on all DME items quickly and accurately.

To take advantage of any or all of these services, or if you have any questions, problems, or ideas please call DME at:

- 800-626-6653 (U.S.)
- 800-387-6600 (Canada)

Part prints or system design prints may be sent in the following ways:

- dme_appl_eng@dme.net
- 248-544-5707 (U.S.) fax
- 905-677-5280 (Canada) fax

DME offers you a wide range of services from component selection to on-site system installation. Our ever-growing list of services include the ability to:

- Analyze the best system to fit your needs
- Assist in system design
- Perform computerized system analysis and resin qualification before any metal is cut
- Marry your system to the mold base, plates and components required
- Provide quotations for and perform all of the special machining required
- Assemble and wire the system
- Check mechanical fit of all components and perform electrical load testing
- Assist with system start-up and maintenance

All of which gives you ... more time to concentrate on cavities and cores!

Terms and Conditions of Sale

DME COMPANY LLC ("SELLER") TERMS AND CONDITIONS OF SALE

1. **ACCEPTANCE OF TERMS:** Seller's offer is expressly conditioned upon Buyer's acceptance of these Terms and Conditions, and Seller expressly objects to any additional or different terms proposed by Buyer. Any subsequent purchase order issued by Buyer shall constitute Buyer's agreement to these Terms and Conditions. Any contrary terms and conditions contained in any purchase order, facility entry form, or other instrument issued by the Buyer are expressly rejected and shall not apply to this transaction. Unless otherwise specified in the quotation, Seller's quotation shall expire 30 days from its date and may be modified or withdrawn by Seller before receipt of Buyer's conforming purchase order.

2. **PAYMENT TERMS:** Payment is due in accordance with any applicable progress, advance or other agreed upon payment schedule, or, if no such schedule has been agreed to, no later than 30 days from the date of invoice. Buyer shall pay a late payment charge computed at the lower of 1.5% per month on any overdue balance, or the maximum rate permitted by law. No cash discount is provided. If at any time Seller reasonably determines that Buyer's financial condition or payment history does not justify continuation of Seller's performance, Seller shall be entitled to require full or partial payment in advance or otherwise restructure payments, request additional forms of payment security, suspend its performance or terminate the order.

3. DELIVERY

3.1 In the United States, products are sold FCA Incoterms 2020 point of origin; for export sales, terms are FCA Incoterms port of export. Unless otherwise agreed in writing, title and risk of loss shall pass at the time of shipment. Buyer is responsible for all taxes, duties, fees, or other governmental charges related to its purchase of goods, with the sole exception of taxes on Seller's income. Unless otherwise agreed, Buyer shall pay all packing and delivery costs.

3.2. Seller's quoted lead times and targeted delivery dates are good faith estimates and are not binding on Seller. Buyer's acceptance of delivery of Seller's products from the carrier shall constitute a waiver of any claim for delay. If Seller notifies Buyer that the products are ready for shipment and Buyer delays delivery, then Seller may charge Buyer a storage fee equal to 1.5% of the contract price per month for each month of delay. Such storage fees are in addition to any other remedies Seller may have.

3.3. Buyer shall have a reasonable opportunity to inspect any products prior to shipment. Products shall be deemed to be accepted upon the earlier of: (i) inspection at Seller's plant (provided that no reasonable objection is then raised by Buyer), or (ii) if no inspection is requested, then at shipment. If an objection is made during inspection, then Products shall be deemed accepted upon resolution of the objection by Seller.

4. WARRANTY:

4.1. Seller's express product warranty be as stated in DME's order specification documentation and shall run from the date of shipment (the "Warranty Period"). During the Warranty Period, Seller warrants that the products and services sold hereunder will be free from material defects in material, workmanship and title (the "Warranty").

4.2. If, during the Warranty Period, Seller reasonably determines that the products do not meet the Warranty, then Seller shall, at its option, repair or replace the defective product or component thereof, reperform any defective services at Seller's expense, or refund or credit to Buyer its purchase price for the defective products or services.

4.3. The Warranty will be void and will not apply: (i) when Buyer fails to promptly notify Seller of any alleged defect, (ii) when Buyer fails to properly install, maintain, or operate the products, (iii) to any product or parts thereof with a useful life, under normal operating conditions, inherently shorter than 1 month, or (iv) to products which were not made by Seller or any of Seller's affiliates, provided that in such cases Seller shall use reasonable efforts to pass on to Buyer the manufacturer's warranty.

4.4. If Seller provides any parts or services to repair a product that is not under Warranty, then such parts and services will be billed to Buyer at Seller's prevailing rates for time and materials.

4.5. The Warranty set out above is the sole and exclusive warranty provided by Seller for its products and is in lieu of, and Seller expressly disclaims, all other warranties, express or implied, oral, written or statutory. **THERE ARE NO WARRANTIES OF MERCHANTABILITY OR FITNESS FOR PURPOSE FOR SELLER'S PRODUCTS.**

5. LIMITATION OF LIABILITIES:

5.1. Seller's total liability to Buyer arising out of or resulting from this Contract or related in any way to Seller's products or parts thereof shall not exceed the contract price for such products.

5.2. Seller shall not be liable for loss of profit or revenues, loss of use of products, interruption of business, downtime costs, increased operating costs, or any special, consequential, incidental indirect or punitive damages, whether incurred by Buyer or Buyer's customers.

5.3. Because the conditions of actual production in each end user's plant vary con-

siderably, Buyer assumes all risk for the results obtained by use of Seller's products in the practice of any process, whether in terms of operating costs, general effectiveness, success or failure, and regardless of any oral or written statements made by Seller related to the use of its products.

6. **SECURITY INTEREST.** Buyer agrees that the Seller shall have and retain a purchase money security interest in the Products securing the payment of all sums becoming due hereunder. Such security interest shall attach, upon completion of manufacture, to the Products and to any parts or accessories attached to the Products and to the proceeds of any sale thereof. Buyer represents that the Products are being acquired for use in its business and that such Products will not, without prior written consent of the Seller, be sold or removed from the Buyer's place of business to which delivery is made. Buyer agrees upon Seller's request to execute any financing statements or other documents required to perfect, continue or renew Seller's security interest in the Products.

7. **CANCELLATION:** Unless otherwise agreed, Buyer may cancel all or any part of the order by written notice received by Seller before the completion of the order. On receipt of such cancellation notice, all work on the order or part thereof canceled will be stopped as promptly as is reasonably possible. Buyer will then be invoiced for and will pay to Seller as liquidated damages a cancellation charge. For completed items, the charge will be equal to their established prices. For items not completed, the charge will be equal to 135% of Seller's full cost as determined by Seller in accordance with Seller's standard accounting practices (which includes burden and overhead), plus a charge for any packing and storage, less a credit for the balance of the material as scrap.

8. **RETURNS:** All returned items require a Return Merchandise Authorization (RMA) number from DME. Returns are subject to a quality inspection to validate whether it can be returned to inventory. Mold bases, plates, special components, made-to-order products and other date-sensitive products are non-returnable items. Items returned to DME without prior authorization(RMA) may be returned to sender. Items returned for stated defect or non-conforming reason require detailed explanation. No products are returnable beyond 30 days after receipt.

9. **CONFIDENTIALITY.** Any nonpublic information, including without limitation, Seller's pricing information and the contents of Seller's quotation or proposal and Buyer's purchase order, exchanged between the parties is deemed confidential ("Confidential Information"). Each party agrees to maintain the other party's Confidential Information in confidence, to not disclose the same to any third parties, and to use it only in connection with this sale. These restrictions shall expire two (2) years after the date of disclosure. This provision does not modify or supersede any separate confidentiality or nondisclosure contract signed by the parties.

10. **FORCE MAJEURE:** Seller shall not be liable for any delay in performance or nonperformance which is due to war, fire, flood, pandemic, acts of God, acts of third parties, acts of governmental authority or any agency or commission thereof, accident, breakdown of products, differences with employees or similar or dissimilar causes beyond Seller's reasonable control, including but not limited to, those interfering with production, supply or transportation of products, raw materials or components or Seller's ability to obtain, on terms Seller deem reasonable, material, labor, products or transportation.

11. **MERGER CLAUSE:** This Contract entirely supersedes any prior oral or written representations, correspondence, proposals, or contracts between the parties regarding the products. This writing constitutes the final and total expression of such contract between the parties, and it is a complete and exclusive statement of the terms of that contract.

12. **ASSIGNMENT:** Neither party may assign this Contract without the written consent of the other party, except that Seller may assign this Contract to a third party that acquires substantially all of Seller's assets and Seller may assign the flow of funds arising out of this Contract.

13. **COMPLIANCE WITH LAWS.** Each party agrees to comply with all applicable laws in the performance of its obligations; Buyer shall not trans-ship, re-export, divert or redirect Products outside of the original country of delivery without Seller's prior written consent.

14. **GOVERNING LAW:** This Contract shall be governed by and construed in accordance with the laws of the State of Michigan, without regard to the Convention for the International Sale of Goods (CISG), which shall not apply.

Sales and Ordering Information

U.S.A.

TERMS AND CONDITIONS OF SALE: See previous page.

PHONE ORDERS – TOLL FREE: 800-626-6653. DME's Customer Service Dept. operates Monday through Friday from 8 a.m. to 6 p.m. E.S.T. Calls can be made from anywhere in the continental U.S. and Puerto Rico (Puerto Rico: use "137" prefix instead of "1"). Our Customer Service Representatives will be happy to answer your questions on DME products or services, provide on-the-spot feedback on product availability and shipping details, or take any messages you wish relayed to your local DME sales, manufacturing or technical service representatives.

MAIL ORDERS: If you prefer to order by mail, please address your order to:

- DME Company, 29111 Stephenson Highway, Madison Heights, Michigan 48071-2330, FAX: 888-808-4363
ATTN: Customer Service Dept.

FAX: You may fax your order to:

- DME Customer Service
- 248-544-5113 or 888-808-4363

CHECKS OR MONEY ORDERS: When paying invoices by check or money order, please make payable to DME Company. include remittance copy of invoice and mail to:

DME Company, PO Box 854867 Minneapolis, MN 55485-4867

WALK-IN ORDERS, PICK-UPS AND RETURNS: If desired, ordered products in stock at your nearest DME Service Center can be picked up rather than shipped. Walk-in orders at Service Center locations can also be processed while you wait. Products being returned for repair or exchange should be processed through Customer Service prior to being returned.

SPECIAL MACHINING SERVICES: Prints for quotation on special machining work can be sent by EDI to dme_cad@dme.net.

For delivery information on special mold base orders or to check status of special work in progress please contact Customer Service at 800-626-6653 or email dme@dme.net

CANADA

Terms and Conditions of Sale: See previous page.

Orders, Quotes, Pickups, Returns: Please contact 800-387-6600

Check or Money Orders: Make payable to DME Company. Include remittance copy of invoice and mail to:
5345 Outerdrive - Unit 3, Oldcastle, ONT N9G 0C4.

Hot Runner & Temperature Control Warranty



DME Company

29111 Stephenson Highway, Madison Heights, MI 48071
Tel. 248/398-6000 ▪ FAX 248/544-5113

DME Hot Runner Systems and Temperature Controllers are warranted pursuant to DME Company's standard terms and conditions (see page 5) for the time periods set forth below. The warranty (i) covers items sold and shipped [supplied in accordance with orders placed by the customer with DME on or after JULY 1, 2003], (ii) applies only to the original DME customer and, (iii) is not transferable to subsequent owners of the product except as specifically set forth herein (see Transferability below for conditions).

WARRANTY PERIODS APPLICABLE TO SPECIFIED DME PRODUCTS; COVERAGE STARTS UPON DATE OF SHIPMENT:

Item	Coverage
DME Stellar and Hot One Hot Halves (plates designed, machined & assembled by DME, excluding Electrical Parts) DME-Global Blue Warranty tag installed on Hot Half	Plastic leakage, due to manufacturing defect, within hot runner plates covered for Two (2) years; excluding Gate Detail.
DME StellarONE Fixed and Valve Gate Hot Halves (plates designed, machined & assembled by DME, excluding Electrical Parts) DME-Global Blue Warranty tag provided with components	Plastic leakage, due to manufacturing defect, within hot runner plates covered for ONE (1) year; excluding Gate Detail.
DME Hot One, Stellar & StellarONE Fixed and Valve Gate Manifold and Components (neither plates nor assembly supplied by DME, excluding Electrical Parts) DME-Global Blue Warranty tag provided with components	One (1) year on components only.
DME-CN Smart Fixed Gate and Valve Gate Hot Halves and Manifold & Components (excluding Electrical Parts) DME-Global Black Warranty tag provided with components	No warranty outside of Country of Manufacture. Contact Country of Manufacture for local warranty coverage. Warranty Coverage is not transferrable outside of country of origin.
DME Electrical Parts (all heaters and thermocouples)	One (1) year
DME Mold Controls and Valve Gate Controls (excluding Fuses & Triacs, Power Packs & Trolley as appropriate)	One (1) year - Pumping systems, Valves & Solenoids Two (2) years - Smart Series Mainframes & Modules TSP, TSP Plus & SVG Electronic Controllers

Replacement or repair will be made at the election of DME; implemented at a DME facility and/or by shipment of replacement parts to the customer for installation and/or return of defective parts to DME for repair.

Transferability:

This warranty may be transferred by the original DME Customer to a subsequent owner of the product if all of the following conditions exist: (i) the original DME Customer purchased the product for purposes of re-sale or other immediate transfer and DME was made aware of these purposes at the time of purchase in writing, (ii) within thirty (30) days from the date of invoice, DME is notified in writing of the transfer and provided with the name of the new owner (hereafter "Transferee"), the contact person of the Transferee and the Transferee's address.

Exclusions:

- Normal wear of the system and components including, but not limited to: Nozzle Tips, Nozzle Seal Rings, and Electrical connectors
- Damage to the critical seal-off areas on the manifold, nozzle bodies, or in the mating cavities or cavity inserts caused by improper assembly, operation, disassembly and maintenance
- Wear or damage resulting from corrosion or processing of abrasive/aggressive resins
- Damage due to failure to follow recommended operation and maintenance procedures specified in the DME Hot Runner Manual, Hot Runner Nameplate, Service Bulletins, User Manuals or failure to follow standard industry operation and maintenance procedure
- Damage caused by abuse, neglect, and failure to adhere to DME instructions and operational recommendations
- Damage caused by improper installation, operation and maintenance
- Damage resulting from modifications to the product or component parts, abuse or neglect
- Failure caused by modifications made to the product without the prior written approval of DME
- Damage resulting from operation of products at injection pressures greater than 20,000 psi (1360 bar) on Hot One, Stellar & Smart One VG Systems; unless specifically designed and manufactured for higher pressure applications in agreement with manufacturer
- Damage or failure caused by the product's inability to perform as a component of a system design not supplied by DME
- Operator absence or operator error
- Operator maintenance and training capability
- Electrical interruptions
- Events beyond the control of DME
- Errors or actions by a third party
- Non-compliance with local laws, codes, ordinances or regulations codes or bylaws unless DME is informed of them by our customer at the time of order placement

DME Hot Runner Overview

DME:

Your essential resource for hot runner solutions



Whether your application requires best-in-class components or a turnkey hot-half system, DME has a hot runner solution that meets your needs.

DME: An Essential Resource for Hot Runner Productivity

Moldmakers, molders and mold designers worldwide look to DME for essential hot runner solutions — whether that is a single, best-in-class component or a complete, fully functioning hot half system. Offering the industry's broadest range of hot runner products and services as well as an unsurpassed knowledge and expertise, DME is committed to helping customers achieve maximum productivity, reliable operation, and better performance.

System Solutions

DME offers a comprehensive family of hot runner systems built on our modular architecture making custom configuration easy and quick.

Systems include:

- Stellar® Micromolding Systems engineered for tight pitch molding
- The Hot One 250, 375 and 625 series



A wide range of DME nozzles allows versatility in system selection



Stellar Micromolding Nozzles provide application flexibility

...from components and manifolds to turnkey hot halves



TURNKEY SYSTEMS



SERVICE



Our goal is simple: to be an essential resource for your molding challenges.

Every step of the way.

Specialized Systems

As one of the world's leading hot runner manufacturers, we recognize that some application challenges demand specialized solutions. Offerings include:

- Stellar Manifold and Components
- Stellar Hot Halves
- Hot One Manifold and Components
- Hot One Hot Halves

Knowledge That Gives You an Advantage

Our team of trained, experienced experts can help you with needs analysis, design, configuration, operation, and all the other services that enable you to focus on your core business.

- Applications engineering
- Moldflow analysis

Service and Support to Keep You Productive

DME provides essential support to keep your hot runner systems in-service. Our dedicated hot runner service center is staffed by trained, experienced technicians who support DME systems, as well as other brands, to provide help when and where you need it, every step of the way.



Stellar & Hot One Systems are custom configured for your application

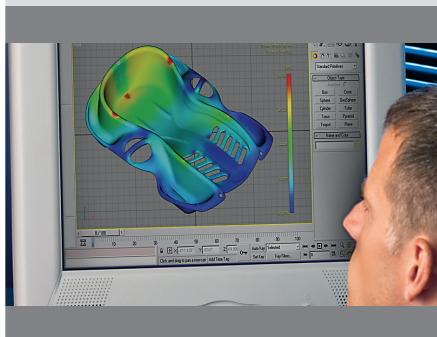

Moldflow predictive analysis optimizes part design and lowers costs



DME Hot Runner Service Center provides total support for your hot runner system

Resin Application Key

Good
 Contact DME
 Not recommended

Polymer Viscosity Key

L=Low M=Medium H=High

The values expressed in grams are for reference only and are determined by using a nominal wall thickness of 1.8mm (.070") and unfilled poly-propylene Part dimension, wall thickness, length of fill within part, mold conditions and molding parameters must also be considered.

NOTE: If flame retardant is present in the desired resin grade, please contact DME for product suitability or application guidance.

GENERIC POLYMER NAME (TRADE NAME) [A=AMORPHOUS or C=CRYSTALLINE]

NOTE: THE CHART BELOW SHOWS **COMMODITY RESINS IN ORANGE TYPE**; ALL OTHERS ARE ENGINEERING RESINS.

TPE (Elastomer) [A]	PE (Polyethylene) [C]	PE GF (Polyethylene) [C]	PS (Polystyrene) [A]	PS GF (Polystyrene) [A]	SAN [A]	TPO [C]	PP (Polypropylene) [C]	PP GF (Polypropylene) [C]	PP TF (Polypropylene) [C]	TPU	ABS [A]	ABS/PC [A]	PMMA (Acrylic) [A]	POM (Acetal) [C]	PA (Nylon) [C]	PA GF (Nylon) [C]	PA MF GF (Minlon) [C]	PPE [A]	PPO (Noryl) [A]	PPO GF (Noryl) [A]	PBT Polyester [C]	PBT GF Polyester [C]	PET [C]	PC (Polycarbonate) [A]	PC GF (Polycarbonate) [A]	PPS [C]	PSU [A]	PSU GF [A]	PUR (Urethane) [A]	LCP [C]	PEI (Ultem) [A]	PEI GF (Ultem) [A]	PEEK [C]	PVC (Flex Vinyl) [A]
---------------------	-----------------------	--------------------------	----------------------	-------------------------	---------	---------	------------------------	---------------------------	---------------------------	-----	---------	------------	--------------------	------------------	----------------	-------------------	-----------------------	---------	-----------------	--------------------	-------------------	----------------------	---------	------------------------	---------------------------	---------	---------	------------	--------------------	---------	-----------------	--------------------	----------	----------------------

NOZZLES	TIP	Min (mm)	Max (mm)	Min (inch)	Max (inch)	Flow Capacity (Grams)			GENERIC POLYMER NAME (TRADE NAME) [A=AMORPHOUS or C=CRYSTALLINE]																																
						Low MFI-16	Medium MFI 7-16	High MFI .02-7	L	L	H	M	H	M	L	M	H	M	M	M	H	H	M	L	H	H	H	H	H	L	H	H	M	H	H	L	L	H	H	H	M
Hot One 250 Series (Coil Heater)	Sprue Tip	2.0	3.1	0.080	0.125	625	475	315	L	L	H	M	H	M	L	M	H	M	M	M	H	H	M	L	H	H	H	H	H	L	H	H	M	H	H	L	L	H	H	H	M
	Standard Point Gate Tip	0.7	2.5	0.028	0.100	200	150	100	L	L	H	M	H	M	L	M	H	M	M	M	H	H	M	L	H	H	H	H	H	L	H	H	M	H	H	L	L	H	H	H	M
Hot One 250 Series (Cast-in Heater)	Sprue Tip	2.0	3.1	0.080	0.125	625	475	315	L	L	H	M	H	M	L	M	H	M	M	M	H	H	M	L	H	H	H	H	H	L	H	H	M	H	H	L	L	H	H	H	M
	Standard Point Gate Tip	0.7	2.5	0.060	0.100	200	150	100	L	L	H	M	H	M	L	M	H	M	M	M	H	H	M	L	H	H	H	H	H	L	H	H	M	H	H	L	L	H	H	H	M
Hot One 375 Series (Coil Heater)	Sprue Tip	3.2	4.7	0.125	0.187	1000	750	450	L	L	H	M	H	M	L	M	H	M	M	M	H	H	M	L	H	H	H	H	H	L	H	H	M	H	H	L	L	H	H	H	M
	Standard Point Gate Tip	0.7	3.1	0.028	0.125	310	200	150	L	L	H	M	H	M	L	M	H	M	M	M	H	H	M	L	H	H	H	H	H	L	H	H	M	H	H	L	L	H	H	H	M
Hot One 375 Series (Cast-in Heater)	Sprue Tip	3.2	4.7	0.125	0.187	1000	750	450	L	L	H	M	H	M	L	M	H	M	M	M	H	H	M	L	H	H	H	H	H	L	H	H	M	H	H	L	L	H	H	H	M
	Standard Point Gate Tip	0.7	3.1	0.060	0.125	310	200	150	L	L	H	M	H	M	L	M	H	M	M	M	H	H	M	L	H	H	H	H	H	L	H	H	M	H	H	L	L	H	H	H	M
Hot One 625 Series (Coil Heater)	Sprue Tip	4.7	7.9	0.187	0.312	1500	1100	750	L	L	H	M	H	M	L	M	H	M	M	M	H	H	M	L	H	H	H	H	H	L	H	H	M	H	H	L	L	H	H	H	M
	Standard Point Gate Tip	3.2	4.4	0.125	0.175	800	550	400	L	L	H	M	H	M	L	M	H	M	M	M	H	H	M	L	H	H	H	H	H	L	H	H	M	H	H	L	L	H	H	H	M
Hot One 625 Series (Cast-in Heater)	Sprue Tip	4.7	7.9	0.187	0.187	1500	1100	750	L	L	H	M	H	M	L	M	H	M	M	M	H	H	M	L	H	H	H	H	H	L	H	H	M	H	H	L	L	H	H	H	M
	Standard Point Gate Tip	3.2	4.4	0.125	0.175	800	550	400	L	L	H	M	H	M	L	M	H	M	M	M	H	H	M	L	H	H	H	H	H	L	H	H	M	H	H	L	L	H	H	H	M
Radius Hot Sprue Bushing	S-Series & T-Series	4.1	4.1	0.160	0.160	700	500	300	L	L	H	M	H	M	L	M	H	M	M	M	H	H	M	L	H	H	H	H	L	H	H	M	H	H	L	L	H	H	H	M	
	E-Series	1.5	1.5	0.060	0.060	300	150	50	L	L	H	M	H	M	L	M	H	M	M	M	H	H	M	L	H	H	H	H	L	H	H	M	H	H	L	L	H	H	H	M	
	ER-Series & TR-Series	3.2	3.2	0.125	0.125	500	300	200	L	L	H	M	H	M	L	M	H	M	M	M	H	H	M	L	H	H	H	H	L	H	H	M	H	H	L	L	H	H	H	M	
	High Performance Series	1.6	1.6	0.062	0.062	300	150	50	L	L	H	M	H	M	L	M	H	M	M	M	H	H	M	L	H	H	H	H	L	H	H	M	H	H	L	L	H	H	H	M	
D-MAX 250 Series High Performance	Sprue Tip	3.2	3.2	0.125	0.125	500	300	200	L	L	H	M	H	M	L	M	H	M	M	M	H	H	M	L	H	H	H	H	L	H	H	M	H	H	L	L	H	H	H	M	
	Standard Point Gate Tip	2.0	3.1	0.080	0.125	700	500	350	L	L	H	M	H	M	L	M	H	M	M	M	H	H	M	L	H	H	H	H	L	H	H	M	H	H	L	L	H	H	H	M	
	Wear Resistant Point Gate Tip	1.3	2.5	0.050	0.100	250	175	125	L	L	H	M	H	M	L	M	H	M	M	M	H	H	M	L	H	H	H	H	L	H	H	M	H	H	L	L	H	H	H	M	
D-MAX 375 Series High Performance	Sprue Tip	1.5	2.5	0.060	0.100	250	175	125	L	L	H	M	H	M	L	M	H	M	M	M	H	H	M	L	H	H	H	H	L	H	H	M	H	H	L	L	H	H	H	M	
	Standard Point Gate Tip	3.2	4.7	0.125	0.187	1100	800	500	L	L	H	M	H	M	L	M	H	M	M	M	H	H	M	L	H	H	H	H	L	H	H	M	H	H	L	L	H	H	H	M	
	Wear Resistant Point Gate Tip	1.3	3.1	0.050	0.125	350	250	200	L	L	H	M	H	M	L	M	H	M	M	M	H	H	M	L	H	H	H	H	L	H	H	M	H	H	L	L	H	H	H	M	
D-MAX 625 Series High Performance	Sprue Tip	1.7	7.9	0.187	0.312	1600	1200	850	L	L	H	M	H	M	L	M	H	M	M	M	H	H	M	L	H	H	H	H	L	H	H	M	H	H	L	L	H	H	H	M	
	250 Series	3.0	4.4	0.125	0.175	900	650	500	L	L	H	M	H	M	L	M	H	M	M	M	H	H	M	L	H	H	H	H	L	H	H	M	H	H	L	L	H	H	H	M	
	High Performance	3.0	4.4	0.125	0.175	900	650	500	L	L	H	M	H	M	L	M	H	M	M	M	H	H	M	L	H	H	H	H	L	H	H	M	H	H	L	L	H	H	H	M	

Available only as a DME Designed and Manufactured Manifold & Components or Fully Assembled and Wired Hot Half

Hot Runner Selection Guide

DME Hot Runner Technology Selection Guide - APRIL 2024 - www.dme.net

Resin Application Key

- Good**
- Contact DME**
- Not recommended**

The values expressed in grams are for reference only and are determined by using a nominal wall thickness of 1.8mm (.070") and unfilled poly- propylene Part dimension, wall thickness, length of fill within part, mold conditions and molding parameters must also be considered.

NOTE: If flame retardant is present in the desired resin grade, please contact DME for product suitability or application guidance.

Polymer Viscosity Key

- L=Low**
- M=Medium**
- H=High**

Recommended Gate Diameter Range

Flow Capacity (Grams)

Viscosity

GENERIC POLYMER NAME (TRADE NAME) [A=AMORPHOUS or C=CRYSTALLINE]

COMMODITY RESINS

TPE (Elastomer) [A]	PE (Polyethylene) [C]	PE GF (Polyethylene) [C]	PS (Polystyrene) [A]	PS GF (Polystyrene) [A]	SAN [A]	TPO [C]	PP (Polypropylene) [C]	PP GF (Polypropylene) [C]	PP TF (Polypropylene) [C]	TPU
---------------------	-----------------------	--------------------------	----------------------	-------------------------	---------	---------	------------------------	---------------------------	---------------------------	-----

NOZZLES	TIP	Min (mm)	Max (mm)	Min (inch)	Max (inch)	Flow Capacity (Grams)			GENERIC POLYMER NAME (TRADE NAME) [A=AMORPHOUS or C=CRYSTALLINE]										
						Low MFI-16	Medium MFI 7-16	High MFI .02-7	TPE (Elastomer) [A]	PE (Polyethylene) [C]	PE GF (Polyethylene) [C]	PS (Polystyrene) [A]	PS GF (Polystyrene) [A]	SAN [A]	TPO [C]	PP (Polypropylene) [C]	PP GF (Polypropylene) [C]	PP TF (Polypropylene) [C]	TPU
Equatemp 3/4" Dia Single-Zone HSB	Sprue Tip	1.2	2.4	0.047	0.094	300	150	75	L	L	H	M	H	M	L	M	H	M	M
	Std Point Gate Tip	0.8	1.5	0.030	0.060	250	175	125											
Equatemp 1" Dia Single-Zone HSB	Sprue Tip	1.5	3.5	0.062	0.140	550	400	250											
	Wear Resistant Point Gate Tip	1.5	2.5	0.060	0.100	250	175	125											
Equatemp 1.5" Dia Single-Zone HSB	Sprue Tip	3.1	5.5	0.125	0.218	1000	775	475											
	Std Point Gate Tip	0.8	2.0	0.060	0.200	500	375	275											
	Wear Resistant Point Gate Tip	1.5	2.5	0.080	0.200	500	375	275											

Equatemp 3/4" Dia Dual-Zone HSB	Sprue Tip	1.5	2.4	0.062	0.094	300	150	75											
	Std Point Gate Tip	0.8	1.5	0.030	0.060	100	75	50											
	Wear Resistant Point Gate Tip	1.5	2.0	0.060	0.080	100	75	50											
Equatemp 1" Dia Dual-Zone HSB	Sprue Tip	2.4	3.5	0.094	0.140	550	400	250											
	Std Point Gate Tip	0.8	2.0	0.030	0.080	250	175	125											
	Wear Resistant Point Gate Tip	1.5	2.5	0.060	0.100	250	175	125											

If you are not finding all the information you require to select a Hot Runner System please contact: Technial Service Department - [DME Tech Service@DME.net](mailto:DME_Tech_Service@DME.net)

Standard Global Manifold & Plastic Materials and Specifications

DME Global Manifolds and Components are standardized worldwide to ensure that even the smallest detail provides operational excellence regardless of where DME hot runner products are used. Whether you're relying on a quick-delivery manifold or an applications-engineered, custom manifold, the DME Global Manifold Standard ensures optimal hot runner performance no matter where in the world it was built.

Key Features of the DME Global Manifold Include:

- Flexible tubular heaters
- Locating rings that fit virtually any injection press platen hole diameters
- Heated Manifold Extension Nozzles available
- High-tolerance, press-fit heaters
- Upper and center Manifold supports constructed of high-strength, low-heat conductive titanium that minimizes heat loss and maintains an even heat profile
- J-type thermocouples are black-and-white, coinciding with the IEC 584-3 International Standard
- Flow channel sizes range from 6mm to 16mm

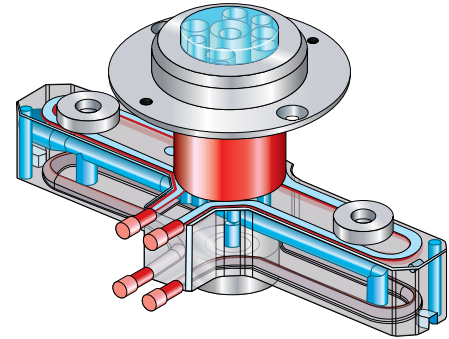

DME customers are assured that DME Manifold Systems are designed and built with a global standard that ensures efficient molding anywhere in the world. And, since replacement parts are identical worldwide, they are readily available wherever your mold is operating, not just where it was built. All DME nozzles, including, Stellar and the Hot One, perform flawlessly with the DME Global Manifold Standard.

PLASTIC MATERIAL PROCESS CONDITIONS											
MATERIAL	STANDARD RESIN SYMBOL	PROCESS TEMPERATURE		MOLD TEMPERATURE		HOT RUNNER TEMPERATURE		DENSITY MELTING		SOLID DENSITY	
		[°C]	[°F]	[°C]	[°F]	[°C]	[°F]	[g/cm ³]	[lbs/inch ³]	[g/cm ³]	[lbs/inch ³]
Styrene Butadiene	SB	210	410	70	158	230	446	0.93	0.0366	1.02	0.0369
Polyurethane	PUR	220	428	45	113	240	464	0.93	0.0366	1.11	0.0401
Styrene-acrylonitrile	SAN	230	446	80	176	255	491	0.99	0.0358	1.08	0.0390
Polystyrene	PS	210	410	45	113	230	446	0.95	0.0343	1.05	0.0379
Polycarbonate	PC	300	572	80	176	330	626	1.08	0.0390	1.20	0.0434
Polyphenylene Oxide-Styrene	PPO	260	500	80	176	300	572	0.99	0.0358	1.13	0.0408
Polyethylene	PE	200	392	25	77	225	437	0.74	0.0267	0.96	0.0347
Polypropylene	PP	225	437	40	104	245	473	0.73	0.0264	0.91	0.0329
Polyether-etherketone	PEEK	330	626	165	329	370	698	1.13	0.0408	1.37	0.0495
Polyphenylene Sulfide	PPS	300	572	110	230	330	626	1.53	0.0553	1.70	0.0614
Polybutylene Terephthalate	PBT	265	509	60	140	290	554	1.44	0.0520	1.57	0.0567
Polyamide 6	PA 6	220	428	90	194	250	482	0.98	0.0354	1.14	0.0412
Polyamide 66	PA 66	255	491	90	194	280	536	1.09	0.0394	1.26	0.0455
Thermal Plastic Elastomers	TPE	240	464	35	95	265	509	0.78	0.0282	0.90	0.0325
Polyoxymethylene (Polyacetal)	POM	180	356	100	212	200	392	1.16	0.0419	1.42	0.0513
Polymethyl Methacrylate	PMMA	235	455	70	158	250	482	1.09	0.0394	1.18	0.0426
Acrylonitrile Butadiene Styrene	ABS	225	437	70	158	250	482	0.95	0.0343	1.08	0.0390

NOTE: Temperature and density values shown above are general, and may not apply to your application. Please refer to proper processing data for the resin grade intended for your specific application. Failure to use temperature settings appropriate to the specific resin and resin grade intended for your application may result in poor part quality, or inability to produce acceptable molded parts.

Bushing Selection

HOT SPRUE BUSHING TIP STYLE

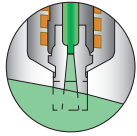

**SPRUE GATE TIP
STANDARD / EXTENDED**

For use where gate vestige is allowed. Provides low resistance to flow with excellent flow rates. Extended style provides additional stock for machining profiles or part contours.

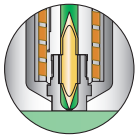

**RING GATE TIP
STANDARD / EXTENDED**

Ideal for low vestige commodity and engineering grade resin applications. The Ring Gate features a sealed tip for efficient shut-off at the part surface. Available with standard or wear resistant needles. Extended style provides additional stock for machining profiles or part contours.



POINT GATE TIP

Suitable for high viscosity resins, engineering plastics and applications requiring optimum gate cosmetics with minimal gate vestige. Available with standard or wear resistant needles.

BUSHING TIP AND PLASTIC MATERIAL COMPATIBILITY

NOZZLE	THERMOPLASTIC RESIN TYPE																						
	AMORPHOUS							SEMI-CRYSTALLINE															
	SB	PUR *	PEI *	SAN *	PS	PC *	PPO *	PE	PP	PEEK	PPS *	PET *	PBT *	PA *	TPE *	POM *	PMMA *	ABS	TPO *	ABS/PC *	PPE/PS *	PSU	LCP
SPRUE GATE TIP STANDARD / EXTENDED	●	●	●	●	■	●	●	■	●	▲	●	●	●	●	●	●	●	●	●	●	●	▲	▲
RING GATE TIP STANDARD / EXTENDED	●	●	●	●	■	●	●	●	●	▲	●	●	●	●	●	●	●	●	●	●	●	▲	▲
POINT GATE TIP	●	●	●	●	■	●	●	■	●	▲	●	●	●	●	●	●	●	●	●	●	●	▲	▲

■ Green – Works well with this resin
 ● Yellow – Contact DME Engineering for guidance
 ▲ Red – Not recommended

Hot Runner Quote Request Form

EMAIL TO DME_TECH_SERVICE@DME.NET OR FAX

United States: 888-808-4363 • Canada: 800-461-9965 • International: 248-398-7394

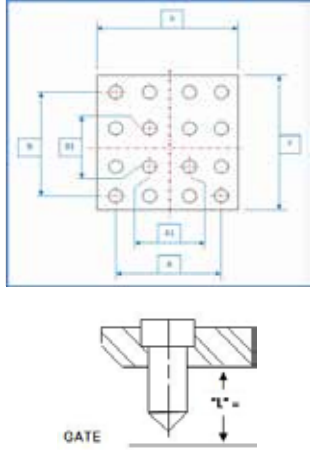
	DME 29111 Stephenson Highway Madison Heights, MI. 48071-2383	Applications Engineering QUOTE REQUEST FORM Email to: mailto: DME_Tech_Service@dme.net																		
Tech Service Approval, Final Drawings and In-House Due Date Required for Firm Quote - QUOTE TYPE <input type="checkbox"/> Preliminary <input type="checkbox"/> Firm																				
Customer's In-House Date Requirement																				
Date		Sales Rep																		
Company		Contact																		
Address		Phone																		
Address		Fax																		
City		E-Mail																		
State	Zip	Acct#																		
		End User																		
Molding Material		Melt Temp deg.																		
Manufacturer		Range (min) (max)																		
Filler <input type="checkbox"/> None <input type="checkbox"/> Glass <input type="checkbox"/> Other	Percent %																			
Flame Retardant <input type="checkbox"/> Yes <input type="checkbox"/> No	Melt Flow Index																			
Color Changes <input type="checkbox"/> Yes <input type="checkbox"/> No		Mold Temp deg.																		
New Mold	Retrofit	DME Mold Base to be Quoted																		
Mold Base Size		Mold Base Drawings Supplied																		
Gating Into	<input type="checkbox"/> Part <input type="checkbox"/> Dimple <input type="checkbox"/> Runner																			
Gate Style	StellarONE (Fixed Point/Sprue Tip only) / Hot One	StellarONE (Valve Gate)																		
	<input type="checkbox"/> Sprue <input type="checkbox"/> Ext Sprue <input type="checkbox"/> Tip/Point <input type="checkbox"/> WR	<input type="checkbox"/> VG-Bodiless <input type="checkbox"/> VG-Full Body <input type="checkbox"/> VG-Full Body Ext'd																		
	<input type="checkbox"/> Other	<input type="checkbox"/> VG-Sprue																		
Number of Drops	Number of Cavities	Control: <input type="checkbox"/> Pneumatic <input type="checkbox"/> Hydraulic *** 700 PSI MAX***																		
Part Name	Part Number	Job #																		
Part Drawing Supplied <input type="checkbox"/> Yes <input type="checkbox"/> No	Sample Supplied <input type="checkbox"/> Yes <input type="checkbox"/> No																			
Wall Thickness of Part	CAD Data Supplied <input type="checkbox"/> Yes <input type="checkbox"/> No																			
Part Weight <input type="checkbox"/> Grams <input type="checkbox"/> Ounces	Total Shot Weight <input type="checkbox"/> Grams <input type="checkbox"/> Ounces																			
Runner Weight <input type="checkbox"/> Grams <input type="checkbox"/> Ounces																				
Type of Quote Requested	<input type="checkbox"/> M&C (system) <input type="checkbox"/> Hot Half - Plate Steel <input type="checkbox"/> #2 (standard) <input type="checkbox"/> 420SS <input type="checkbox"/> iControl																			
<table border="1" style="width:100%; border-collapse: collapse;"> <tr> <td>Drop Spacing</td> <td>A=</td> </tr> <tr> <td></td> <td>A1=</td> </tr> <tr> <td>Drop Spacing</td> <td>B=</td> </tr> <tr> <td></td> <td>B1=</td> </tr> <tr> <td>Plate Width</td> <td>X=</td> </tr> <tr> <td>Plate Length</td> <td>Y=</td> </tr> <tr> <td>Molding Elevation</td> <td>L=</td> </tr> <tr> <td># of Columns</td> <td></td> </tr> <tr> <td># of Rows</td> <td></td> </tr> </table>		Drop Spacing	A=		A1=	Drop Spacing	B=		B1=	Plate Width	X=	Plate Length	Y=	Molding Elevation	L=	# of Columns		# of Rows		
Drop Spacing	A=																			
	A1=																			
Drop Spacing	B=																			
	B1=																			
Plate Width	X=																			
Plate Length	Y=																			
Molding Elevation	L=																			
# of Columns																				
# of Rows																				
NOTES:																				

Available online @ www.DME.net/request-quote

Hot One Hot Runner Technology | Hot Runner Quote Request Form

Table of Contents

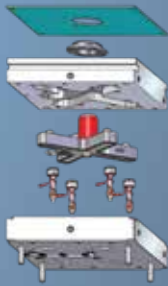

Hot Runner Technology.....17-19

The best solution for precision thermoplastic micromolding



StellarONE Hot Runner System.....20-27

Cost efficient and capable, the DME StellarONE gives you all you need in a melt delivery system at an economical price.



Stellar Micromolding Hot Runner Systems.....28-33

The best solution for precision thermoplastic micromolding.



Hot One Nozzles.....34-60

A long-standing industry standard in user-friendliness and affordability.

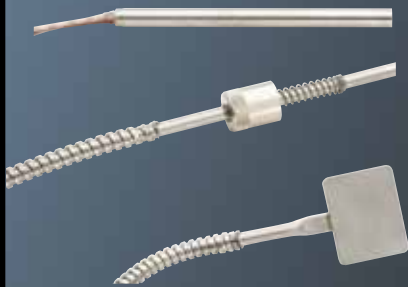

Components: Heaters & Thermocouples47-52

Custom-configured manifolds, manifold and component systems, and complete hot half assemblies for quick delivery.

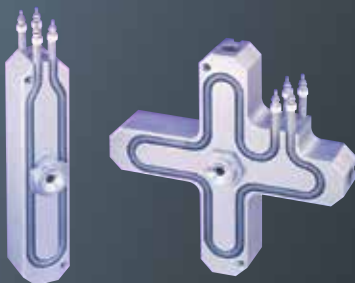

Meteor® Hot Runner Systems.....54-60

Custom-configured manifolds, manifold and component systems, and complete hot half assemblies for quick delivery.

Hot Runner Technology

A LONG-STANDING
INDUSTRY STANDARD
IN USER-FRIENDLINESS
AND AFFORDABILITY

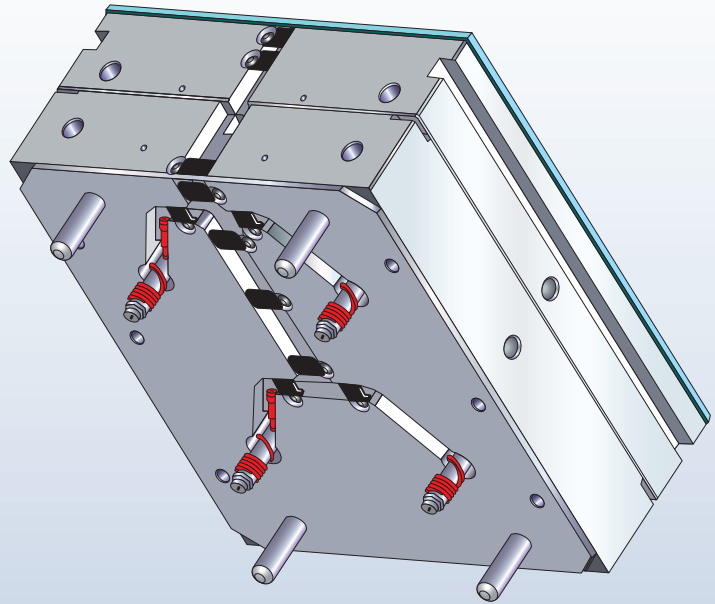

Features and Benefits

Our ongoing customer-driven philosophy has fostered many new and innovative systems and components, allowing you to take advantage of more than seven decades of leadership in injection molding technology. DME's Hot Runner Technology has become an industry standard in technology, user-friendliness, and affordability. Available in two styles – Manifold & Components and as a complete Hot Half System.

Tubular Heated Systems

Using exclusive, distributed wattage Tubular Heaters, the DME Hot Runner Systems can process many engineering grade resins. Tubular Heaters reduce the number of zones of heat required, providing the added benefit of lowering your temperature control costs.

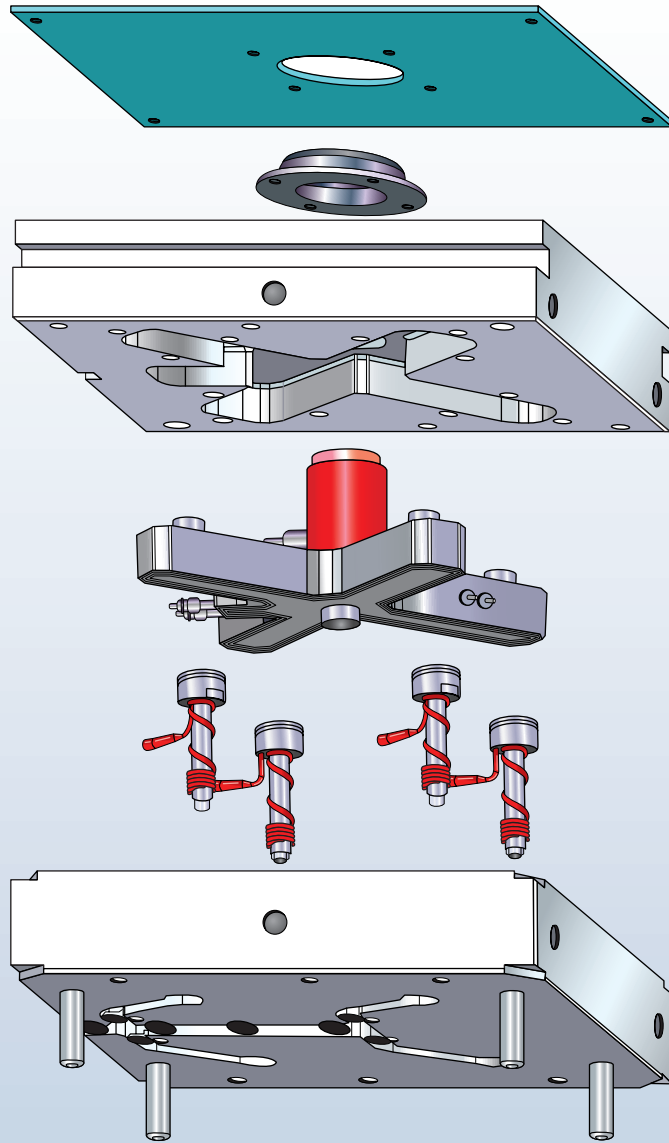

DME's Hot Runner Technology has become an industry standard in technology, user-friendliness, and affordability. Available in two styles – Manifold & Components and as a complete Hot Half System.

Nozzles

Each DME nozzle series has its own advantages and characteristics to meet your needs.

Stellar Nozzles



"CIA"/"EHA" Nozzles

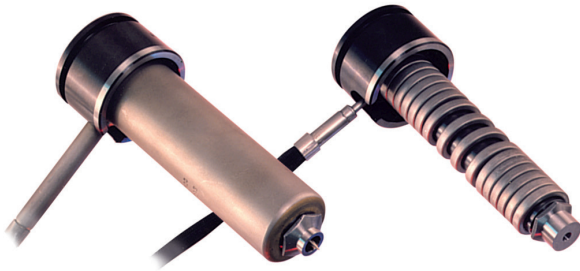

Nozzles

The DME Hot One is accompanied by a nozzle offering that allows versatility in system selection to best suit the material and molded part configuration. DME offers different styles of nozzles: The "EHA" series, using square coil heaters and the "CIA" series, using replaceable, slip-on high performance heaters. Each nozzle series has its own characteristics and advantages.

For example, the "EHA" series of nozzles can be used for many applications using commodity resins with low crystallinity. The "CIA" series, with high performance heaters developed exclusively for DME, can be used for all applications, especially engineering grade resins with a high degree of crystallinity.

"EHA"/"CIA" Nozzle Tips



- **Sprue Gate/Extended Sprue Gate** – Used primarily in applications where gate vestige is not a concern. Offers minimal flow resistance and handles most resins very effectively. Extended style provides additional stock for machining of runner profiles or part contours.

- **Point Gate** – Used for applications needing optimum gate cosmetics, this tip can run a wide range of resins. It has two interchangeable needles, standard and wear resistant. The wear resistant needle is especially useful for abrasive or filled material applications.

- **Full Body Point Gate** – Used for low vestige, commodity grade resin applications. The Full Body Point Gate features a sealed tip for efficient shut-off at the parting line.

Ordering Options: Use this information and our design and machining guidelines to build your system, or take advantage of DME Applications Engineering services to help you select the system best suited to your requirements. Then, either order the steel and components to construct your system or let DME do all of the machining, assembly and wiring for you.

Solutions

THE BALANCED SOLUTION

Every plastic part is unique and requires a tailored solution.

The successful molding of a plastic part relies on the optimal balance of temperature and pressure. The ideal process integrates each element of the system from plastic pellet, design analysis, through the molding process, to the final molded part. It is this holistic approach to mold design and processing that differentiates DME from other hot runner companies.

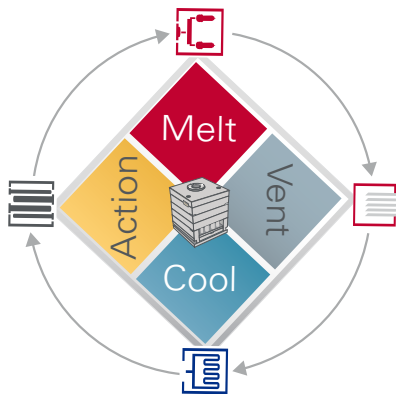

We draw upon DME's years of technical application experience and wide breadth of advanced technologies to build high performance and reliable systems that enable you to reliably produce the perfect plastic part at the lowest possible cost.



From pellet to part our designed system carefully balances thermal transfer and flow pressure, of even the most complex geometries, to generate high output quality parts.



The DME Molding Design Process

Reference for details to choose the optimal DME Hot Runner Technology
Hot Runner Selection Guide (see page 10)

or contact

Hot Runner Service via email - DME_Tech_Services@DME.net

Control Your Destiny

Precise temperature control and management are critical elements to successfully producing high quality parts. DME's Smart Series® Temperature Controller Systems deliver unparalleled performance for ALL hot runner systems. When combining the DME StellarONE hot runner system with a Smart Series Controller, the results are unmatched. User-friendly performance, Plug-And-Play system approach, Intuitive diagnostic software and System Optimization are just several features that allow all processors to fine tune and control the injection molding process.

The Smart Series Controller can be configured with standard features or can be built to suit valve gate control too! Available in both Hydraulic or Pneumatic, our valve gate control provides the user full management over the valve gate sequence, critical when molding complex or large parts. Same great features built on the same platform to deliver high quality molded parts.

Whether your molding a simple single cavity with PP or 96 cavities with a high-grade glass filled engineered resin we have the controller for you. DME understands not all applications require high end temp control however there are many that do. That's why we offer a wide range of Smart Series controllers from single zone push button to fully advanced 216 zones of control to meet your application needs.

The DME Smart Series blue box set the industry standard over 30 years ago and is still a reliable solution for many molding applications.



DME Mainframes: Available in 2, 5, 8, & 12-zones • Heavy-duty Welded Construction • RoHS/WEEE Compliant

TSM1512 MODULES: Color touch screen digital display providing readouts for: Actual Temperature, Current Mode, Percentage Power and Current Reading • Leak Alarm

SSM1512 Modules: Maintains simplicity of operation with simultaneous display of setpoint and temperature

ITSP Plus SmartSeries controller brings another level of sophistication and at the same time offer sa plug and play ease of use.

ITSP Plus (Touch Screen Panel) offers users friendly performance by utilizing an intuitive touch screen display. The controller automatically employs diagnostics to ensure optimal hardware configuration, easy startups, and continuously monitors for ground fault and current measurements. At the heart of each controller is a patented "all-in-one" control card designed for reliability, configured in a modular 6-zone per card/15 amps per zone, that can be field calibrated and with universal power supply the TSP is a snap to connect. All these features are wrapped in a robust high quality, compact, solid metal enclosure with heavy-duty industrial connectors making this controller and easy choice for your next application.



TempMaster M2 Superior Control To Maximize Molding Performance The TempMaster M2 controller offers the precision control needed to make perfect parts. All TempMaster controllers feature the NEW APS (Adaptive Process System) technology providing faster processing and response speed.



SVGP Pneumatic & SVG Hydraulic Sequential Valve Gate Controllers

The SVGP and SVG controllers provides the user with full control over valve gate flow sequence, critical when molding complex or large parts. All SVG(P) controllers feature the NEW APS (Adaptive Process System) technology providing faster processing and response speed. The sequential valve gate technology is integrated in a precise hot runner control unit with all available features or standalone unit and has been designed to easily connect to any valve gate system. Each controller provides precise filling control with performance graphs displaying time and position, with up to 4 steps per cycle. Each controller is able to accommodate for 2-shot applications as well.



StellarONE

Key To A Balanced Thermal Dynamics System

A Global offering from DME, providing a common design platform no matter where your molds are built. This DME-Engineered solution is available as a Manifold & Components offering, or as a complete Hot Half, ready to interface with your cavity plate.

Cost efficient and capable, the DME StellarONE provides all you need in a melt delivery system at an economical price.

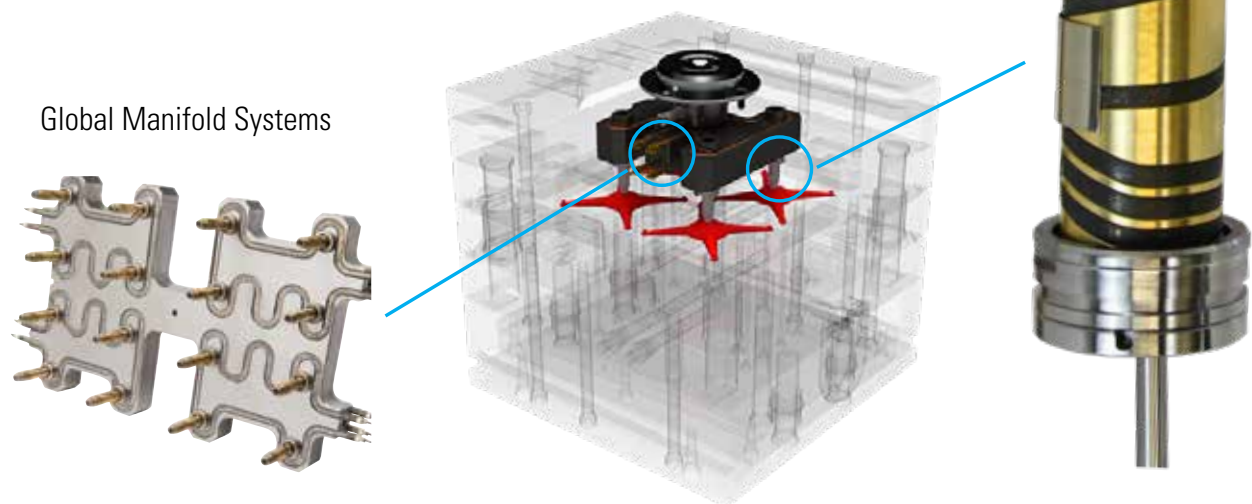

Global Manifold Systems

StellarONE RETHINKING MELT DELIVERY

Precision Temperature

Our heat control technology offers stable heating with minimized loss. Direct heating via replaceable brass sleeve heaters for diffusion into the nozzle body. Thermocouples are ideally positioned for accurate temperature control, all serviceable within the molding machine. The result is an even temperature profile along the entire length of the nozzle guaranteeing high process reliability. The smart system balance allows for the use with a broad range of polymers.

More Processing Control

Accurate melt distribution from the barrel to the gate and throughout the cavity delivers consistent molding results. Our specially designed melt seal directly at the gate, ensures quick color change performance.

Extreme Durability

Our systems are built to perform through the life cycle of the tool 24/7. Our Hardened Nozzle body can handle melt pressures up to 20,000 psi.

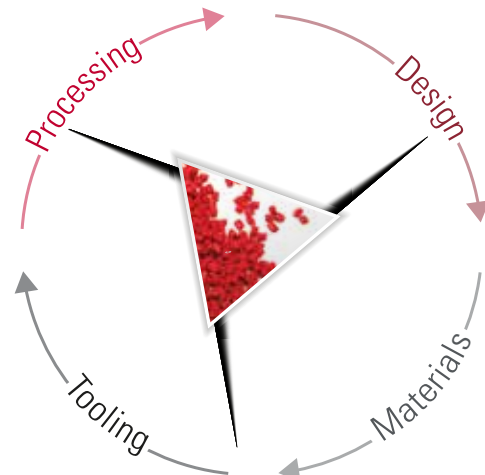

StellarONE

Features:

- 6 different nozzle sizes to match your application requirements
- Tip styles include Bodiless, Full Body, Full Body with Extended Sprue, and Sprue Gate
- Available with Pneumatic or Hydraulic cylinders
- Actuation options include individual (sequential) or all open/all close
- Available for 2- to 32-drops, using a naturally balanced manifold flow path design

Benefits:

- Valve Gate style available for superior gate cosmetics, sequential part filling and the elimination of trimming and secondary operations
- Valve Gate Cylinder design allows removal/setting of Valve Pins without system disassembly
- Easily matched with DME Pneumatic or Hydraulic control systems
- Replacement/spare part availability in North America
- A value offering to provide a competitive edge over other manufacturers
- Designed, Manufactured and Supported by DME North America



Stellar Hot Runner Manifold Systems

StellarONE Hot Runner Manifold Systems are designed with balanced runner systems to maximize part productivity. The final design is based on process variables such as resin, shot size, gate vestige and overall system performance requirements.

- All Manifold systems come complete with: Tubular Heaters, Thermocouples, Titanium Pressure Pads, Manifold & Nozzle Locators to suit.
- All Manifold systems are supplied with full system drawings.
- Balanced Design: Thermal and geometric balancing provides uniform production, cavity to cavity.
- Turn-Key Systems: These are ready to install, eliminating the need for machining, wiring and testing the hot half.
- Tubular Heating Element: These provide excellent heat distribution throughout the manifold and standard replacement parts are available off the shelf for quick service
- Streamlined Flow Channels: To ensure optimized melt flow and come complete with fully radiused corners and plugs.
- Hardened Steel Construction: To provide a solid, stress-free foundation.
- Titanium Pressure Pads minimize heat transfer to the plates, ensuring a consistent and efficient heat profile.
- Mold flow analysis is available, on request, for all manifold inquiries.



StellarONE

NOZZLE SUB-ASSEMBLIES

StellarONE-04 Series Nozzle Sub-Assembly

A	1 NOZZLE HEATER (230V)	WATTS	2 TC	3 TC RETAINER 2 PC.	4 SEAL RING
50	SONH10047	180	SOTC10150-J	SONHC04	EHR7154
60	SONH10057	250			
70	SONH10067	250			
80	SONH10077	250			
90	SONH10087	250			
100	SONH10097	250	SOTC10200-J		
110	SONH10107	260			
120	SONH10117	270			
130	SONH10127	280			
140	SONH10137	290			
150	SONH10147	300			

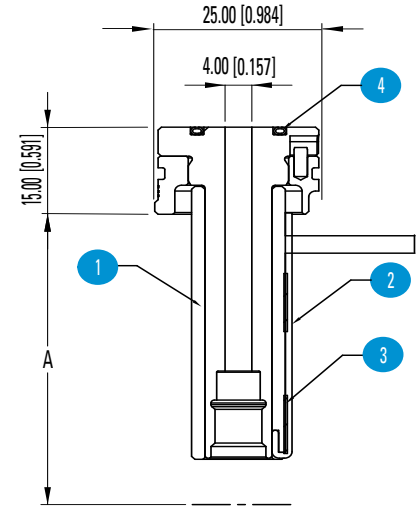

StellarONE-06 Series Nozzle Sub-Assembly

A	1 NOZZLE HEATER (230V)	WATTS	2 TC	3 TC RETAINER 2 PC.	4 SEAL RING
50	SONH18045	300	SOTC10150-J	SONHC06	EHR7154
60	SONH18055	350			
70	SONH18065	400			
80	SONH18075	400			
90	SONH18085	450	SOTC10200-J		
100	SONH18095	450			
120	SONH18115	550			
140	SONH18135	600			
160	SONH18155	700	SOTC10250-J		
180	SONH18175	800			

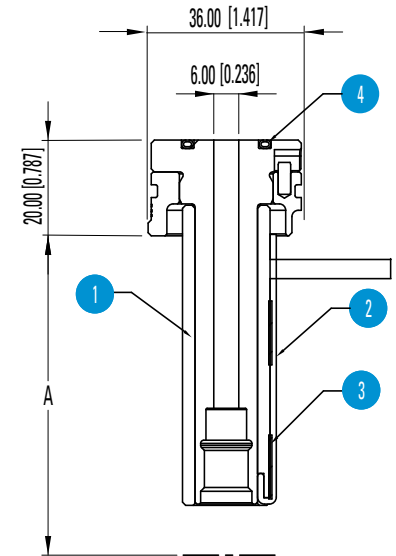

StellarONE-08 Series Nozzle Sub-Assembly

A	1 NOZZLE HEATER (230V)	WATTS	2 TC	3 TC RETAINER 2 PC.	4 SEAL RING
50	SONH20045	350	SOTC10150-J	SONHC08	EHR7155
60	SONH20055	350			
70	SONH20065	400			
80	SONH20075	400			
90	SONH20085	450	SOTC10200-J		
100	SONH20095	450			
110	SONH20105	450			
120	SONH20115	550			
140	SONH20135	600	SOTC10250-J		
160	SONH20155	650			
180	SONH20175	700			

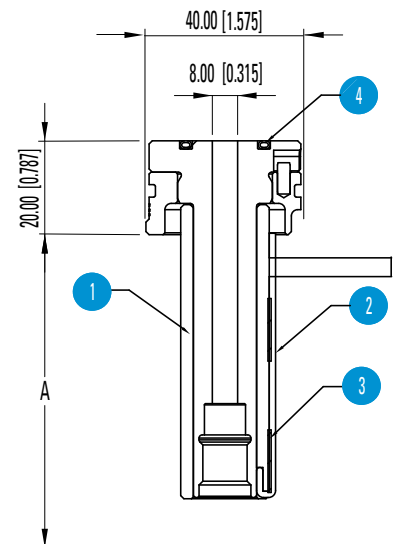

StellarONE

NOZZLE SUB-ASSEMBLIES

StellarONE-10 Series Nozzle Sub-Assembly

A	1 NOZZLE HEATER (230V)450	WATTS	2 TC	3 TC RETAINER 2 PC.	4 SEAL RING
50	SONH22045	450	SOTC10150-J	SONHC10	EHR7155
60	SONH22055	450			
70	SONH22065	500			
80	SONH22075	500			
90	SONH22085	550	SOTC10200-J		
100	SONH22095	550			
110	SONH22105	600			
120	SONH22115	600			
140	SONH22135	700	SOTC10250-J		
160	SONH22155	700			
180	SONH22175	700			

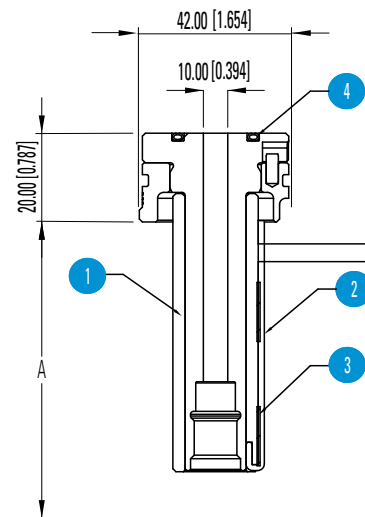

StellarONE-12 Series Nozzle Sub-Assembly

A	1 NOZZLE HEATER	WATTS	2 TC	3 TC RETAINER 2 PC.	4 SEAL RING
50	SONH24043	500	SOTC10150-J	SONHC12	EHR7001
60	SONH24053	550			
70	SONH24063	700			
80	SONH24073	800			
90	SONH24083	850	SOTC10200-J		
100	SONH24093	850			
110	SONH24103	900			
120	SONH24113	950			
140	SONH24133	950	SOTC10250-J		
160	SONH24153	1000			
180	SONH24173	1100			
200	SONH24193	1100			

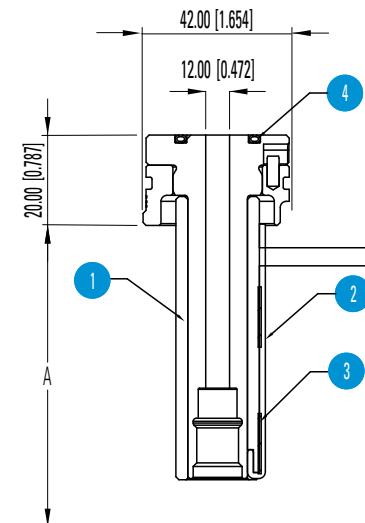

StellarONE-16 Series Nozzle Sub-Assembly

A	1 NOZZLE HEATER	WATTS	2 TC	3 TC RETAINER 2 PC.	4 SEAL RING
70	SONH28062	550	SOTC10200-J	SONHC16	EHR7156
80	SONH28072	550			
90	SONH28082	700			
100	SONH28092	800			
120	SONH28112	850	SOTC10250-J		
140	SONH28132	850			
160	SONH28152	900			
180	SONH28172	950			
200	SONH28192	950	SOTC10350-J		
220	SONH28212	1000			
240	SONH28232	1050			
260	SONH28252	1050			
280	SONH28272	1100			
300	SONH28292	1100			

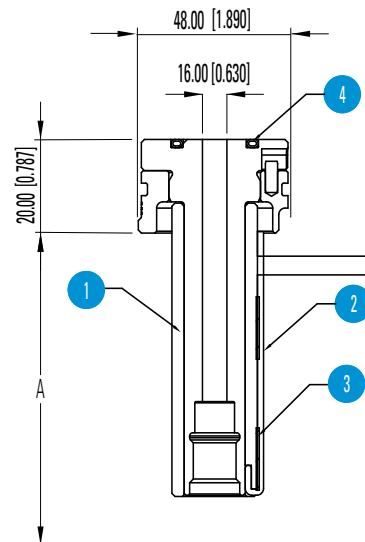

StellarONE Thermal Gate Tips

Point Gate (Bodiless)

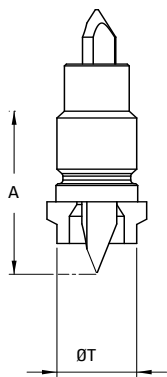

SERIES	GATE TIP	ITEM NUMBER	INCLUDES		T DIA.
			NEEDLE	RETAINER	
StellarONE-04	Standard	SOPGA04	SOPGN0401	SOBRT0401	8
	Wear Resistant	SOPGA04-WR	SOPGN0401-WR		
StellarONE-06	Standard	SOPGA06	SOPGN0601	SOBRT0601	10
	Wear Resistant	SOPGA06-WR	SOPGN0601-WR		
StellarONE-08	Standard	SOPGA08	SOPGN0801	SOBRT0801	12
	Wear Resistant	SOPGA08-WR	SOPGN0801-WR		
StellarONE-10	Standard	SOPGA10	SOPGN1001	SOBRT1001	14
	Wear Resistant	SOPGA10-WR	SOPGN1001-WR		
StellarONE-12	Standard	SOPGA12	SOPGN1201	SOBRT1201	16
	Wear Resistant	SOPGA12-WR	SOPGN1201-WR		
StellarONE-16	Standard	SOPGA16	SOPGN1601	SOBRT1601	20
	Wear Resistant	SOPGA16-WR	SOPGN1601-WR		

Point Gate (Full Body)

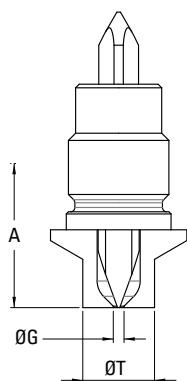

SERIES	GATE TIP	ITEM NUMBER	INCLUDES		G DIA.	T DIA.
			NEEDLE	RETAINER		
StellarONE-04	Standard	SOFBOP04	SOPGN0401	SOFRT0401	1.0	8
	Wear Resistant	SOFBOP04-WR	SOPGN0401-WR			
StellarONE-06	Standard	SOFBOP06	SOPGN0601	SOFRT0601	1.5	10
	Wear Resistant	SOFBOP06-WR	SOPGN0601-WR			
StellarONE-08	Standard	SOFBOP08	SOPGN0801	SOFRT0801	1.5	12
	Wear Resistant	SOFBOP08-WR	SOPGN0801-WR			
StellarONE-10	Standard	SOFBOP10	SOPGN1001	SOFRT1001	1.5	14
	Wear Resistant	SOFBOP10-WR	SOPGN1001-WR			
StellarONE-12	Standard	SOFBOP12	SOPGN1201	SOFRT1201	2.0	16
	Wear Resistant	SOFBOP12-WR	SOPGN1201-WR			
StellarONE-16	Standard	SOFBOP16	SOPGN1601	SOFRT1601	2.5	20
	Wear Resistant	SOFBOP16-WR	SOPGN1601-WR			

Point Gate (Full Body Extended)

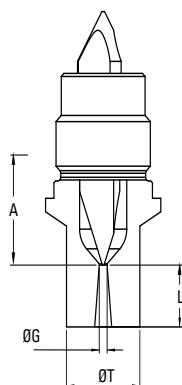

SERIES	GATE TIP	ITEM NUMBER	INCLUDES		G DIA.	T DIA.	L
			NEEDLE	RETAINER			
StellarONE-04	Standard	SOFBOP04EX	SOPGN0401	SOFRT0402	1.0	8	10
	Wear Resistant	SOFBOP04EX-WR	SOPGN0401-WR				
StellarONE-06	Standard	SOFBOP06EX	SOPGN0601	SOFRT0602	1.5	10	10
	Wear Resistant	SOFBOP06EX-WR	SOPGN0601-WR				
StellarONE-08	Standard	SOFBOP08EX	SOPGN0801	SOFRT0802	1.5	12	10
	Wear Resistant	SOFBOP08EX-WR	SOPGN0801-WR				
StellarONE-10	Standard	SOFBOP10EX	SOPGN1001	SOFRT1002	1.5	14	10
	Wear Resistant	SOFBOP10EX-WR	SOPGN1001-WR				
StellarONE-12	Standard	SOFBOP12EX	SOPGN1201	SOFRT1202	2.0	16	10
	Wear Resistant	SOFBOP12EX-WR	SOPGN1201-WR				
StellarONE-16	Standard	SOFBOP16EX	SOPGN1601	SOFRT1602	2.5	20	10
	Wear Resistant	SOFBOP16EX-WR	SOPGN1601-WR				

Sprue Gate

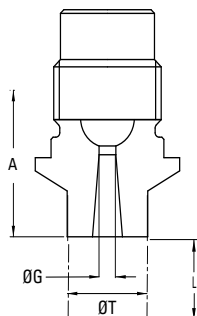

Series	Gate Tip	Item Number	G DIA.	T DIA.	L
StellarONE-04	Sprue Gate	SOSRT0401	1.5	8	NA
	Extended Sprue Gate	SOSRT0402			10
StellarONE-06	Standard	SOSRT0601	2	10	NA
	Extended Sprue Gate	SOSRT0602			10
StellarONE-08	Standard	SOSRT0801	2.5	12	NA
	Extended Sprue Gate	SOSRT0802			10
StellarONE-10	Standard	SOSRT1001	2.5	14	NA
	Extended Sprue Gate	SOSRT1002			10
StellarONE-12	Standard	SOSRT1201	3.0	16	NA
	Extended Sprue Gate	SOSRT1202			10
StellarONE-16	Standard	SOSRT1601	3.0	20	NA
	Extended Sprue Gate	SOSRT1602			10

StellarONE Valve Gate Tips

Valve Gate (Sprue Tip)

SERIES	GATE TIP	ITEM NUMBER	G DIA.	T DIA.	L
StellarONE-06	Standard	SOSRT0603	1.5	10	NA
	Extended Sprue Gate	SOSRT0604			10
StellarONE-08	Standard	SOSRT0803	2.5	12	NA
	Extended Sprue Gate	SOSRT0804			10
StellarONE-10	Standard	SOSRT1003	2.5	14	NA
	Extended Sprue Gate	SOSRT1004			10
StellarONE-12	Standard	SOSRT1203	4.0	16	NA
	Extended Sprue Gate	SOSRT1204			10
StellarONE-16	Standard	SOSRT1603	5.0	20	NA
	Extended Sprue Gate	SOSRT1604			10

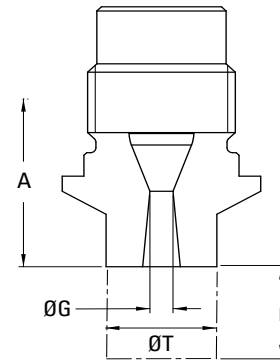

Valve Gate (Bodiless)

SERIES	GATE TIP	ITEM NUMBER	INCLUDES		T DIA.
			NEEDLE	RETAINER	
StellarONE-06	Standard	SOVGBA06	SOVGN0601	SOBRT0602	10
	Wear Resistant	SOVGBA06-WR	SOVGN0601-WR		
StellarONE-08	Standard	SOVGBA08	SOVGN0801	SOBRT0802	12
	Wear Resistant	SOVGBA08-WR	SOVGN0801-WR		
StellarONE-10	Standard	SOVGBA10	SOVGN1001	SOBRT1002	14
	Wear Resistant	SOVGBA10-WR	SOVGN1001-WR		
StellarONE-12	Standard	SOVGBA12	SOVGN1201	SOBRT1202	16
	Wear Resistant	SOVGBA12-WR	SOVGN1201-WR		
StellarONE-16	Standard	SOVGBA16	SOVGN1601	SOBRT1602	20
	Wear Resistant	SOVGBA16-WR	SOVGN1601-WR		

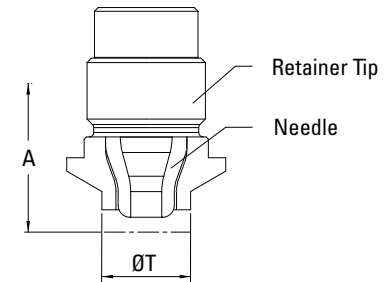

Valve Gate (Full Body)

SERIES	GATE TIP	ITEM NUMBER	INCLUDES		G DIA.	T DIA.
			NEEDLE	RETAINER		
StellarONE-06	Standard	SOVGFBA06	SOVGN0601	SOFRT0603	1.5	10
	Wear Resistant	SOVGFBA06-WR	SOVGN0601-WR			
StellarONE-08	Standard	SOVGFBA08	SOVGN0801	SOFRT0803	2.5	12
	Wear Resistant	SOVGFBA08-WR	SOVGN0801-WR			
StellarONE-10	Standard	SOVGFBA10	SOVGN1001	SOFRT1003	2.5	14
	Wear Resistant	SOVGFBA10-WR	SOVGN1001-WR			
StellarONE-12	Standard	SOVGFBA12	SOVGN1201	SOFRT1203	4.0	16
	Wear Resistant	SOVGFBA12-WR	SOVGN1201-WR			
StellarONE-16	Standard	SOVGFBA16	SOVGN1601	SOFRT1603	5.0	20
	Wear Resistant	SOVGFBA16-WR	SOVGN1601-WR			

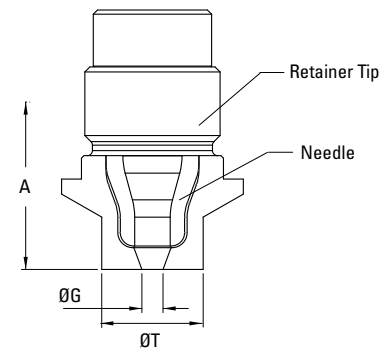

Valve Gate (Full Body Extended)

SERIES	GATE TIP	ITEM NUMBER	INCLUDES		G DIA.	T DIA.	L
			NEEDLE	RETAINER			
StellarONE-06	Standard	SOVGFBA06EX	SOVGN0601	SOFRT0604	1.5	10	10
	Wear Resistant	SOVGFBA06EX-WR	SOVGN0601-WR				
StellarONE-08	Standard	SOVGFBA08EX	SOVGN0801	SOFRT0804	2.5	12	10
	Wear Resistant	SOVGFBA08EX-WR	SOVGN0801-WR				
StellarONE-10	Standard	SOVGFBA10EX	SOVGN1001	SOFRT1004	2.5	14	10
	Wear Resistant	SOVGFBA10EX-WR	SOVGN1001-WR				
StellarONE-12	Standard	SOVGFBA12EX	SOVGN1201	SOFRT1204	4.0	16	10
	Wear Resistant	SOVGFBA12EX-WR	SOVGN1201-WR				
StellarONE-16	Standard	SOVGFBA16EX	SOVGN1601	SOFRT1604	5.0	20	10
	Wear Resistant	SOVGFBA16EX-WR	SOVGN1601-WR				

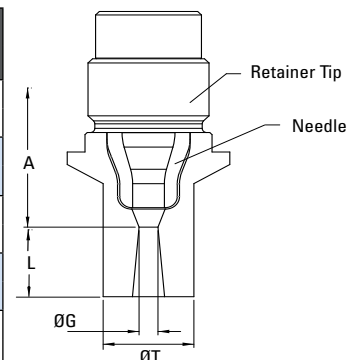

StellarONE Cylinders & Valve Pins

PNEUMATIC & HYDRAULIC CYLINDERS

SERIES	D-DIA. REF.	SEAL KIT #	VALVE PIN TUNING PAD (Ø)
StellarONE-06			
30 Series-B	70mm	SM30BSK	PTPSC30025A (Ø11.5)
StellarONE-08			
40 Series-B	80mm	SM40BSK	PTPSC40025A (Ø12.0)
StellarONE-10			
50 Series-B	92mm	SM50BSK	PTPSC50025A (Ø14.0)
StellarONE-12			
65 Series-A	110mm	SM65ASK	PTPSC65025A (Ø16.0)
StellarONE-16			
80 Series-A	128mm	SM80ASK	PTPSC80025A (Ø17.0)

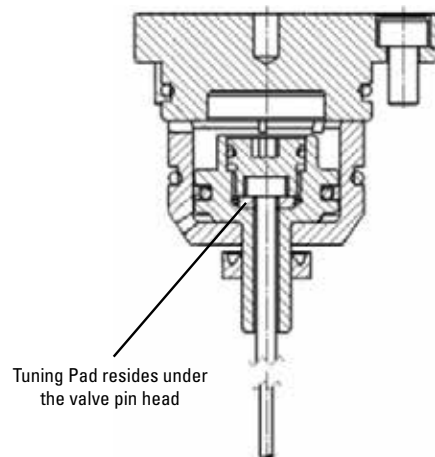

VALVE PINS

PART NUMBER	Ø D	Ø D1	L (MM)	TUNING PAD
P25VP40210A	2.5	4	210	PTPSC30025A
P25VP40260A			260	
P30VP40230A	3		230	PTPSC40025A
P30VP40280A			280	
P37VP40250A	3.7		250	PTPSC50025A
P37VP40280A			280	
P37VP40330A		330		
P57VP60270A	5.7	6	270	PTPSC65025A
P57VP60320A			320	
P57VP60370A			370	
P57VP60420A			420	
P57VP60450A			450	
P57VP80270A	7.7	8	270	PTPSC80025A
P57VP80320A			320	
P57VP80370A			370	
P57VP80420A			420	
P57VP80450A			450	

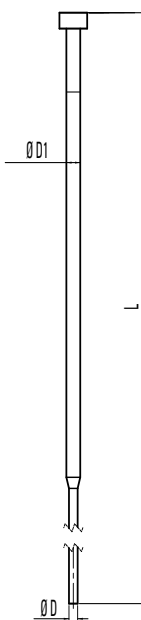

Hot Runner Systems | StellarONE Cylinders & Valve Pins

MINIMUM DROP PITCH

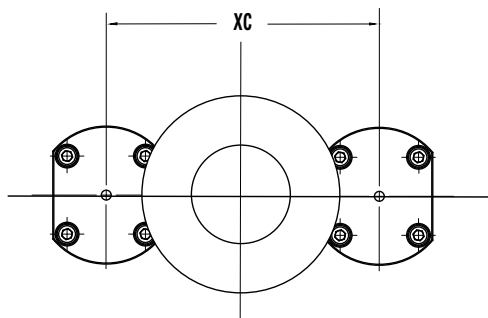

VALVE GATE SERIES	X1 min	Y1 min	X min	Y min	XC
StellarONE-06	54	72	90	84	90
StellarONE-08	61	82	98	92	98
StellarONE-10	70	94	106	100	106
StellarONE-12	86	112	118	112	118
StellarONE-16	104	130	130	124	130

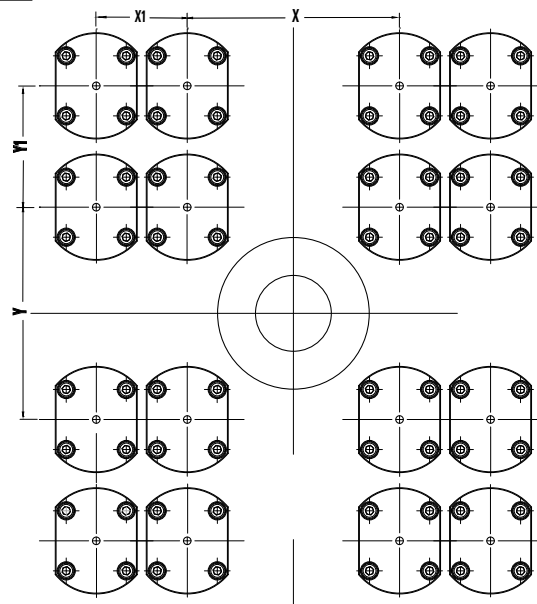

StellarONE Cylinders & Valve Pins

StellarONE Cylinders & Valve Pins

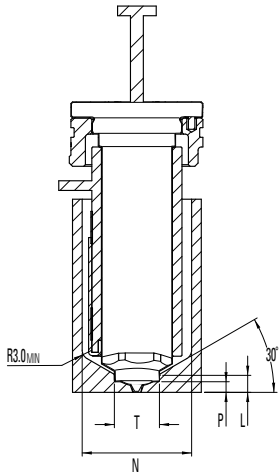

BODILESS - VALVE GATE

VALVE GATE	L	N	P	T
StellarONE-06	5.6	30	3.1	10
StellarONE-08	5.6	32	3.3	12
StellarONE-10	5.6	34	3.3	14
StellarONE-12	7.0	36	4.6	16
StellarONE-16	7.5	42	4.6	20

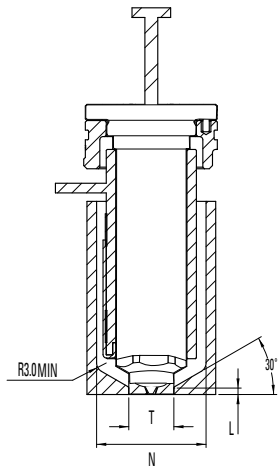

FULL BODY - VG/THERMAL

VG/THERMAL	L	N	T
StellarONE-04	3.0	18	8
StellarONE-06	4.0	30	10
StellarONE-08	4.0	32	12
StellarONE-10	4.0	34	14
StellarONE-12	4.0	36	16
StellarONE-16	4.0	42	20

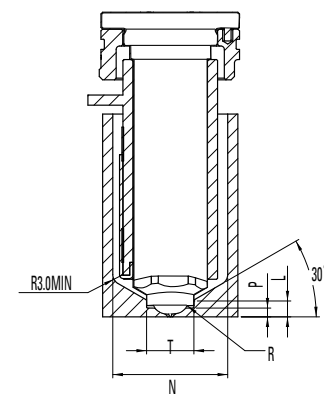

BODILESS - THERMAL

THERMAL	L	N	P	R	T
StellarONE-04	4.7	18	2.6	3.5	8
StellarONE-06	4.9	30	2.6	3.6	10
StellarONE-08	5.0	32	2.6	5.5	12
StellarONE-10	5.0	34	2.6	6.5	14
StellarONE-12	7.0	36	4.6	7.0	16
StellarONE-16	7.4	42	4.6	10.0	20

CAD data available at: www.DME.net/cad-data

Stellar Micromolding Hot Runner Systems

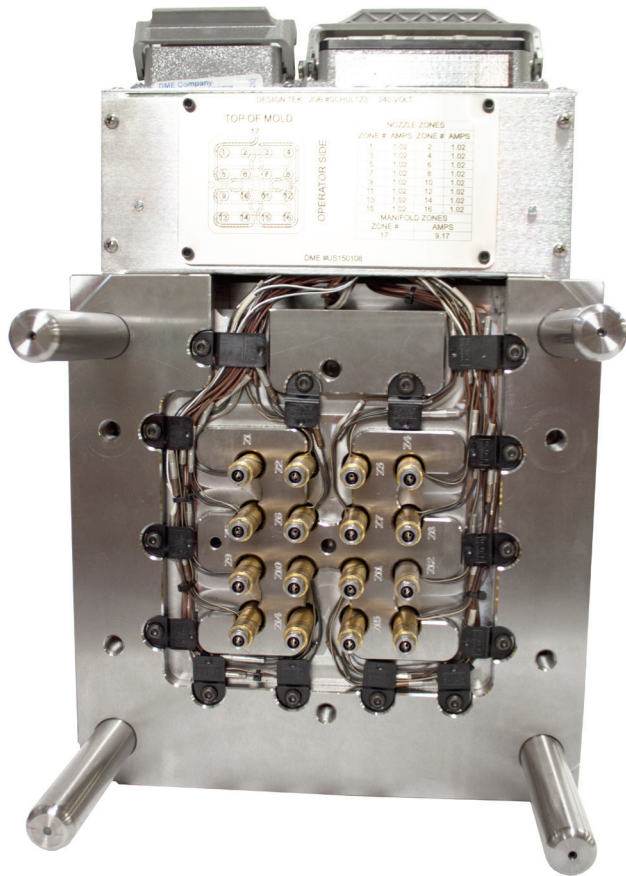

PROVEN SOLUTIONS FOR
PRECISION
THERMOPLASTIC
MICROMOLDING

Stellar Hot Runner Systems – Benefits

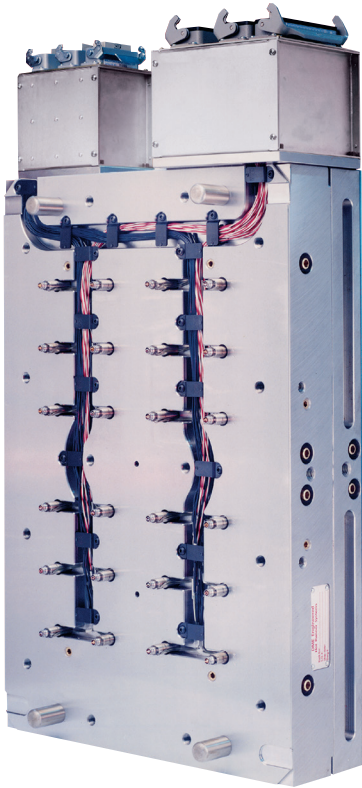

Engineered for the Challenges of Tight Pitch Molding

The DME Stellar™ Hot Runner System brings high performance, exacting precision and flexible, cost-effective modular construction to very small part molding. With as little as 17mm between centers, Stellar is also ideal for high-cavitation molding.

Demand the Best – Demand DME

DME has been a leader in mold technologies for seven decades. Nobody beats DME for quality products, quality service and quick delivery. Like all DME products, Stellar Hot Runner Systems come with your satisfaction 100% guaranteed.

Get the Modular Advantage

Stellar is based on new DME hot runner system architecture to deliver tremendous flexibility. Seven different “A” dimensions, two interchangeable tip options, and a choice of manifold styles enable DME to easily configure a Stellar solution that matches your application.



For a Wide Range of Applications

Stellar is perfect for today's rapidly expanding array of micromolding projects. Stellar was designed to perform in a broad spectrum of applications – including electrical, electronic, medical, and cosmetic packaging. And, Stellar was designed to process demanding engineering resins without property degradation.

Stellar Hot Runner Systems Benefits

High Process Temperature Capability with Precision Heat Profiling

Today's engineered materials challenge hot runner systems with high processing temperatures – often with very narrow operating windows. Stellar hot runner nozzles utilize reliable profiled mini-tubular heaters to ensure optimal heat distribution. In addition, Stellar nozzles are engineered with low conductivity heads and high conductivity tips for consistent thermal performance.

Easy Serviceability – Right in the Machine

Productivity is especially critical when micromolding thousands of parts per hour. Every Stellar Hot Runner System can be rapidly serviced for maximum uptime. Nozzle tips, retainers, mini-tubular heaters and thermocouples are all front-loaded and easily replaced with the mold in the press.

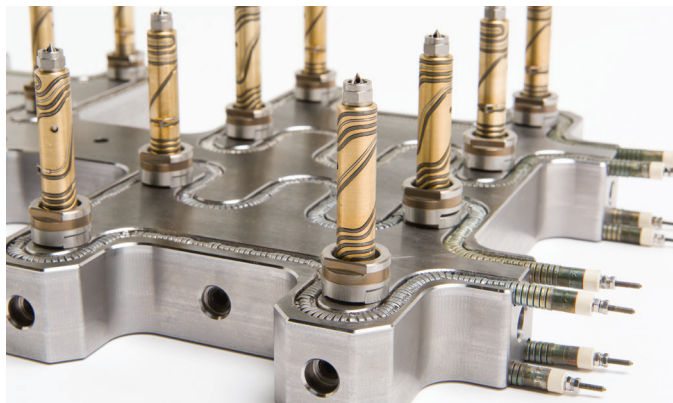

Increase Productivity and Reduce Molding Costs With Stellar-Infused Quick-Change Systems

Now the production efficiencies of hot runner molding can be further enhanced when combined with a Master Unit Die (MUD) Quick-Change Frame. An unlimited number of different parts can be produced with this industry-leading combination of hot runners within a quick-change system because only the MUD Companion Insert Mold is swapped out. The MUD Frame/Hot Runner System remains in the mold.

Combining DME Hot Runners with MUD Quick-Change Systems provides many advantages to virtually any injection molding operation, including:

- Enables molders to use the same DME Hot Runner System with many different cavity and core configurations with MUD Companion Insert Molds
- Quickens production changeovers, often in as little as five minutes
- Provides cost justification for the Hot Runner System and/or the MUD Quick-Change System for multiple tooling projects
- Simplifies design with the use of the MUD Quick-Change Straps

Contact your DME representative or call us today to find out more about how the combination of a DME Hot Runner System and the MUD Quick-Change System will not only substantially increase your production efficiency but significantly reduce your molding costs. Many companies incorporate the DME hot runner/quick-change combo into their Lean initiatives.

Gating Style Selection

Gating Style Selection

Fig. 1 Standard Point Gate Tip Sub-Assembly, [SXG5110](#)

- For use with unfilled resins up to 290°C (550°F)

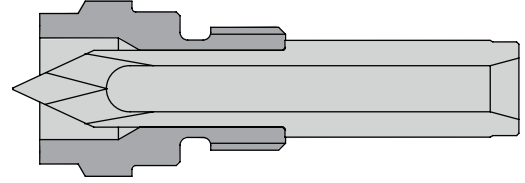

Fig. 2 High Performance Point Gate Tip Sub-Assembly, [SXG5020](#)

- For use with unfilled and filled resins up to 330°C (625°F)

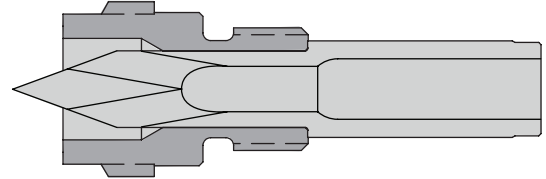

Fig. 3 Sprue Gate Tip, [SXT7040](#) - T=10mm

- For use with unfilled and filled resins up to 330°C (625°F)

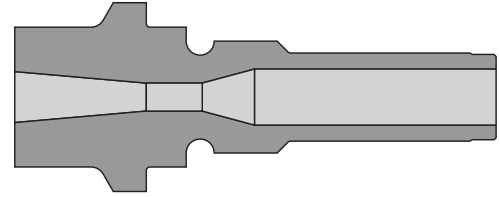

Fig. 4 Sprue Gate Tip, [SXT7140](#) - T=.750

- For use with unfilled and filled resins up to 330°C (625°F)

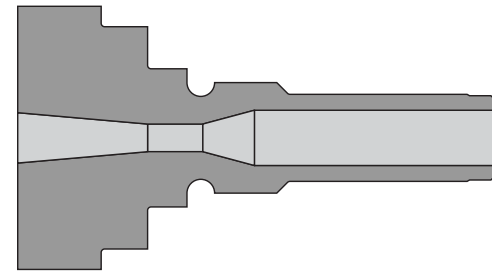

Table 1: Gating Style Item Numbers

TIP SUB-ASSEMBLY ITEM NUMBER	DESCRIPTION	TIP ITEM NUMBER	TIP CTE (10 ⁻⁶ /degC)	RETAINER ITEM NUMBER	GATING STYLE	APPLICABLE STELLAR SYSTEM
SXG5110	Standard Point Gate Tip Sub-Assembly	SXT4010	17.5	SXF5100	Point Gate	Standard
SXG5020	High Performance Point Gate Tip Sub-Assembly	SXT5010	4.5	SXF5000	Point Gate	High Performance
N/A	Sprue Gate Tip	SXT7040	12.8	N/A	Sprue Gate	All
N/A	Sprue Gate Tip	SXT7140	12.8	N/A	Sprue Gate	All

NOTE: All units are in mm.

Gate Details for use with Hardened Steel (50HRC min.)

Fig. 6 Gate Details for Standard Point Gate, High Performance Point Gate Tips (SXG5110 & SXG5020) For gating onto a flat surface or into a recess* ("dimple")

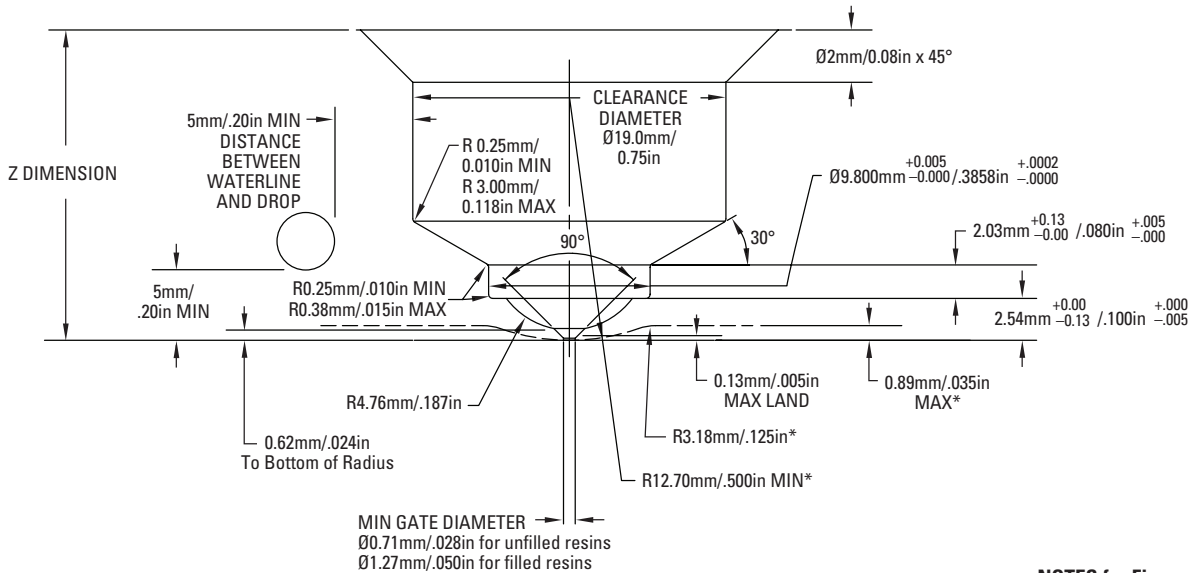
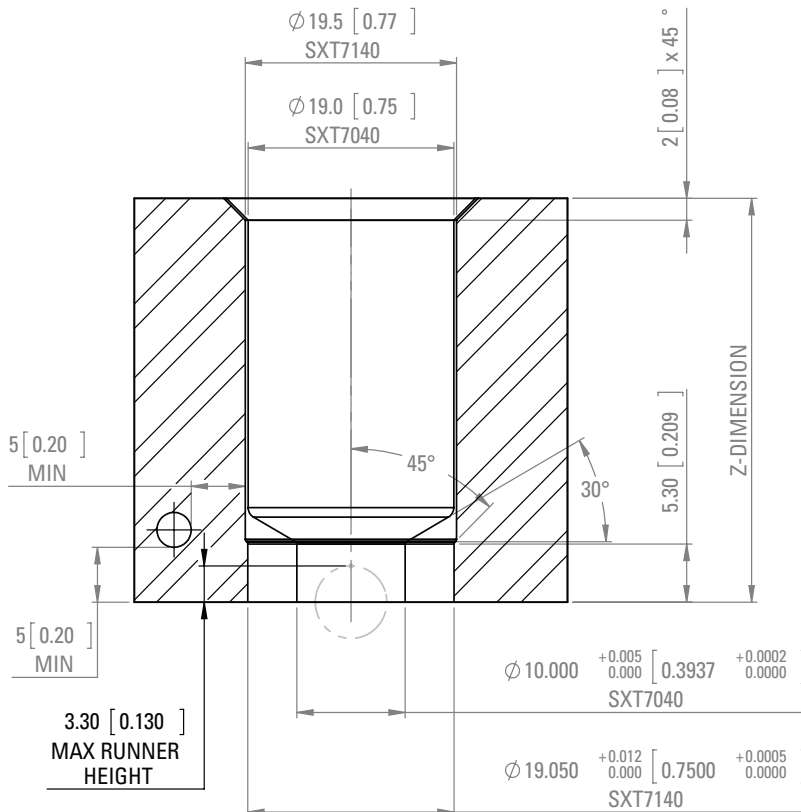

Fig. 7 Gate Details for Sprue Gate Tips, SXT7040 & SXT7140



NOTES for Figure 6 & 7:

1. If gate detail does not properly fit the application, contact DME for assistance about gate detail options.
2. Position gate detail within $\pm 0.013\text{mm} / .0005\text{in}$ from nominal.
3. The gate diameter can be opened by the customer to suit the application. (The land must be re-machined to the maximum dimension after increasing the gate diameter.)
4. Water lines are required in "A" plate for proper gate cooling.
5. Position water lines as close as possible but not closer than the minimum distance shown to provide a safe steel condition.
6. For faster color changes, remove ("decone") the resin from the front of each point gate tip prior to changing colors.
7. The minimum "Z" dimension is 13.00 and the maximum "Z" dimension is 115 for point gate and sprue gate tips.

Hot One Nozzles



ENABLING VERSATILITY
IN SYSTEM SELECTION

250 Series Nozzles (.250 Diameter Flow Channel)

250 Series Nozzle Sub-Assembly

(Add .750 to A dimension for extended sprue gate and extended full body point gate tips.)

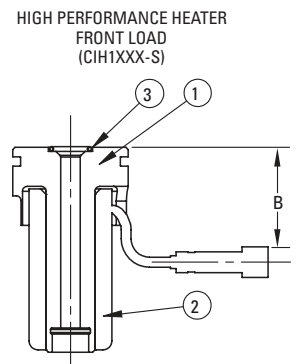
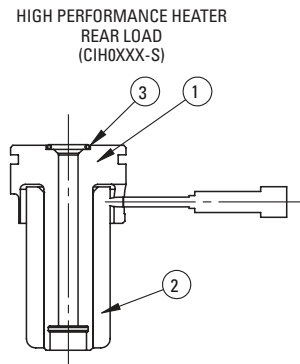
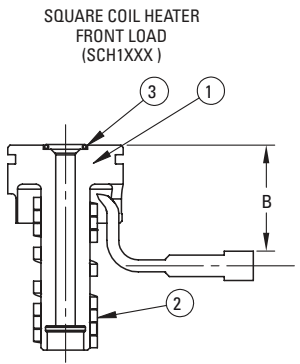
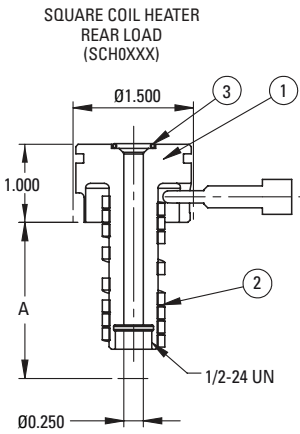

A	B	SUB-ASSEMBLY ITEM NUMBER	1 NOZZLE BODY	2 HEATER	3 SEAL RING
2.000	—	EHA0001	CIB1359	SCH0081	EHR7154
	1.250	EHA1001		SCH1081	
	—	CIA0001S		CIH0081S	
	1.250	CIA1001S		CIH1081S	
2.500	—	EHA0002	CIB1360	SCH0082	
	1.250	EHA1002		SCH1082	
	—	CIA0002S		CIH0082S	
	1.250	CIA1002S		CIH1082S	
3.000	—	EHA0003	CIB1361	SCH0083	
	1.250	EHA1003		SCH1083	
	—	CIA0003S		CIH0083S	
	1.250	CIA1003S		CIH1083S	
3.500	—	EHA0004	CIB1362	SCH0084	
	1.250	EHA1004		SCH1084	
	—	CIA0004S		CIH0084S	
	1.250	CIA1004S		CIH1084S	
4.000	—	EHA0005	CIB1363	SCH0085	
	1.250	EHA1005		SCH1085	
	—	CIA0005S		CIH0085S	
	1.250	CIA1005S		CIH1085S	
5.000	—	EHA0006	CIB1364	SCH0086	
	1.250	EHA1006		SCH1086	
	—	CIA0006S		CIH0086S	
	1.250	CIA1006S		CIH1086S	
6.000	—	EHA0007	CIB1365	SCH0087	
	1.250	EHA1007		SCH1087	
	—	CIA0007S		CIH0087S	
	1.250	CIA1007S		CIH1087S	

WIRING INFORMATION:

Power leads are tan
 Ground leads are green
 Thermocouple leads are black and white
 White is negative (-) and constantan (non-magnetic)
 Black is positive (+) and iron (magnetic)

Replacement Seal Rings

Used between manifold and nozzle to prevent leakage. New seal rings must be installed each time manifold is assembled.

ITEM NUMBER
EHR7154

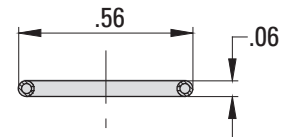

375 Series High Performance Nozzles (.375 Diameter Flow Channel)

375 Series Nozzle Sub-Assembly

(Add .750 to A dimension for extended sprue gate and extended full body point gate tips.)

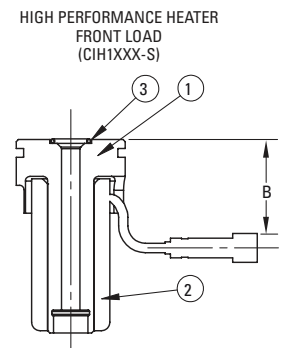
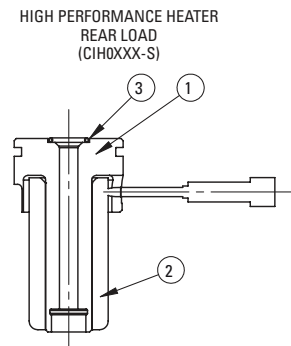
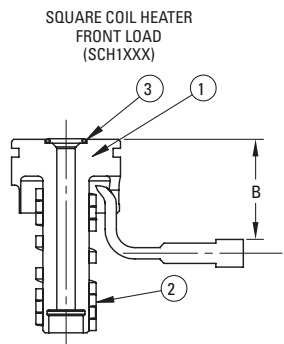
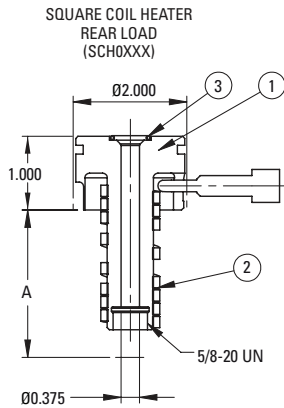

A	B	SUB-ASSEMBLY ITEM NUMBER	1 NOZZLE BODY	2 HEATER	3 SEAL RING
2.000	—	EHA0008	CIB1366	SCH0088	EHR7155
	1.250	EHA1008		SCH1088	
	—	CIA0008S		CIH0088S	
	1.250	CIA1008S		CIH1088S	
2.500	—	EHA0009	CIB1367	SCH0089	
	1.250	EHA1009		SCH1089	
	—	CIA0009S		CIH0089S	
	1.250	CIA1009S		CIH1089S	
3.000	—	EHA0010	CIB1368	SCH0090	
	1.250	EHA1010		SCH1090	
	—	CIA0010S		CIH0090S	
	1.250	CIA1010S		CIH1090S	
3.500	—	EHA0011	CIB1369	SCH0091	
	1.250	EHA1011		SCH1091	
	—	CIA0011S		CIH0091S	
	1.250	CIA1011S		CIH1091S	
4.000	—	EHA0012	CIB1370	SCH0092	
	1.250	EHA1012		SCH1092	
	—	CIA0012S		CIH0092S	
	1.250	CIA1012S		CIH1092S	
5.000	—	EHA0013	CIB1371	SCH0093	
	1.250	EHA1013		SCH1093	
	—	CIA0013S		CIH0093S	
	1.250	CIA1013S		CIH1093S	
6.000	—	EHA0014	CIB1372	SCH0094	
	1.250	EHA1014		SCH1094	
	—	CIA0014S		CIH0094S	
	1.250	CIA1014S		CIH1094S	
7.000	—	EHA0015	CIB1373	SCH0095	
	1.250	EHA1015		SCH1095	
	—	CIA0015S		CIH0095S	
	1.250	CIA1015S		CIH1095S	

WIRING INFORMATION:

Power leads are tan
Ground leads are green
Thermocouple leads are black and white

- White is negative (-) and constantan (non-magnetic)
- Black is positive (+) and iron (magnetic)

Replacement Seal Rings

Used between manifold and nozzle to prevent leakage. New seal rings must be installed each time manifold is assembled.

ITEM NUMBER
EHR7155

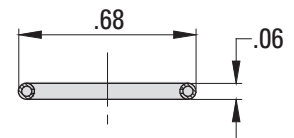

625 Series Nozzles (.625 Diameter Flow Channel)

625 Series Nozzle Sub-Assembly

(Add .750 to A dimension for extended sprue gate and extended full body point gate tips.)

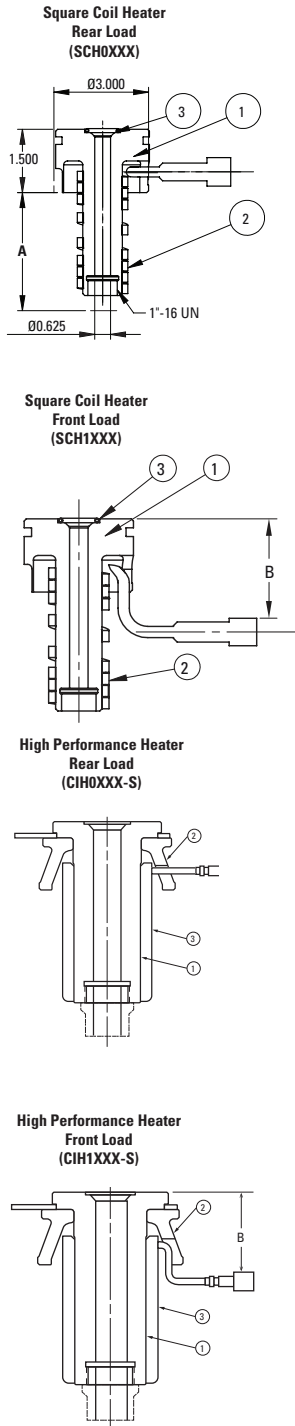

A	B	SUB-ASSEMBLY ITEM NUMBER	1 NOZZLE BODY	2 HEATER	3 SEAL RING
3.000	—	CIA0023S	CIB1381	CIH0104S	EHR7156
	1.75	CIA1023S		CIH1104S	
4.000	—	EHA0016	EHB0074	SCH0096	
	1.75	EHA1016		SCH1096	
	—	CIA0016S	CIB1374	CIH0096S	
	1.75	CIA1016S		CIH1096S	
5.000	—	EHA0017	EHB0075	SCH0097	
	1.75	EHA1017		SCH1097	
	—	CIA0017S	CIB1375	CIH0097S	
	1.75	CIA1017S		CIH1097S	
6.000	—	EHA0018	EHB0076	SCH0098	
	1.75	EHA1018		SCH1098	
	—	CIA0018S	CIB1376	CIH0098S	
	1.75	CIA1018S		CIH1098S	
7.000	—	EHA0019	EHB0077	SCH0099	
	1.75	EHA1019		SCH1099	
	—	CIA0019S	CIB1377	CIH0099S	
	1.75	CIA1019S		CIH1099S	
8.000	—	EHA0020	EHB0078	SCH0100	
	1.75	EHA1020		SCH1100	
	—	CIA0020S	CIB1378	CIH0101S	
	1.75	CIA1020S		CIH1101S	
9.000	—	EHA0021	EHB0079	SCH0101	
	1.75	EHA1021		SCH1101	
	—	CIA0021S	CIB1379	CIH0102S	
	1.75	CIA1021S		CIH1102S	
10.000	—	EHA0022	EHB0080	SCH0102	
	1.75	EHA1022		SCH1102	
	—	CIA0022S	CIB1380	CIH0103S	
	1.75	CIA1022S		CIH1103S	

WIRING INFORMATION:
 Power leads are tan
 Ground leads are green
 Thermocouple leads are black and white

- White is negative (-) and constantan (non-magnetic)
- Black is positive (+) and iron (magnetic)

Replacement Seal Rings

Used between manifold and nozzle to prevent leakage. New seal rings must be installed each time manifold is assembled.

ITEM NUMBER
EHR7156

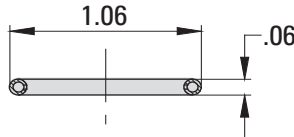

Gate Tip Detail

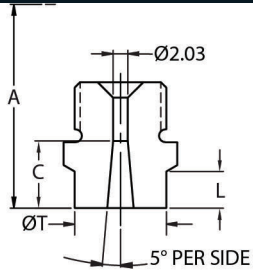

Sprue Gate/Extended Sprue Gate

SERIES	GATE TIP	ITEM NUMBER	B DIA.	T DIA.	L	C		
250	SPRUE GATE	EHT0010	.080	.500	.250	.375		
		EHT0011		.750				
		EHT0012		1.000				
	EXTENDED SPRUE GATE	EHT0013		.500			1.000	1.125
		EHT0014		.750				
		EHT0015		1.000				
375	SPRUE GATE	EHT0016	.125	.500	.250	.375		
		EHT0017		.750				
		EHT0018		1.000				
	EXTENDED SPRUE GATE	EHT0019		.500			1.000	1.125
		EHT0020		.750				
		EHT0021		1.000				
625	SPRUE GATE	EHT0022	.187	1.000	.250	.500		
	EXTENDED SPRUE GATE	EHT0023		1.000	1.000	1.250		

Add .750 to A dimension for extended sprue gate tips.)

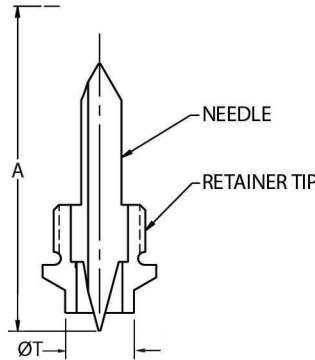

Point Gate (Bodiless)

SERIES	GATE TIP	ITEM NUMBER	T DIA.	INCLUDES	
				NEEDLE	RETAINER TIP
250	STANDARD	EHT0005	.375	EHN0015	EHT0024
		EHT1314			EHT0324
	WEAR RESISTANT	EHT1308			EHT0324
		EHT1313			EHT1324
375	STANDARD	EHT0039	.500	EHN0016	EHT0025
		EHT1312			EHT0325
		EHT1303			EHT1325
	WEAR RESISTANT	EHT1309			EHT0325
		EHT1306			EHT1354
		EHT1311			EHT0326
625	STANDARD	EHT1307	.625	EHN0019	EHT0326
		EHT1310			EHT0326
	WEAR RESISTANT	EHT1307			EHT0326
		EHT1310			EHT1354

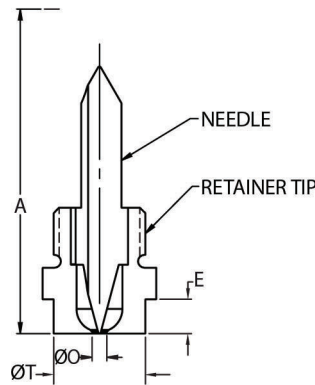

Point Gate (Full Body)

SERIES	TYPE	ITEM NUMBER	T DIA.	O DIA.	E	INCLUDES	
						NEEDLE	RETAINER TIP
250	STANDARD	EHT2001	.375	.060	.187	EHN0015	EHT0026
		EHT2002					EHT0027
		EHT2003					EHT0028
		EHT2004					EHT0029
		EHT2005					EHT1326
	WEAR RESISTANT	EHT2006	EHT1327				
		EHT2007	EHT1328				
		EHT2008	EHT1329				
		EHT2009	EHT0030				
		EHT2010	EHT0031				
375	STANDARD	EHT2011	.500	.100	.230	EHN0016	EHT0032
		EHT2012					EHT0033
		EHT2013					EHT0034
		EHT2014					EHT0035
		EHT2015					EHT1330
	WEAR RESISTANT	EHT2016	EHT1331				
		EHT2017	EHT1332				
		EHT2018	EHT1333				
		EHT2019	EHT1334				
		EHT2020	EHT1335				
625	STANDARD	EHT2021	1.000	.125	.250	EHN0019	EHT0036
	WEAR RESISTANT	EHT2022				EHN0402	EHT1336

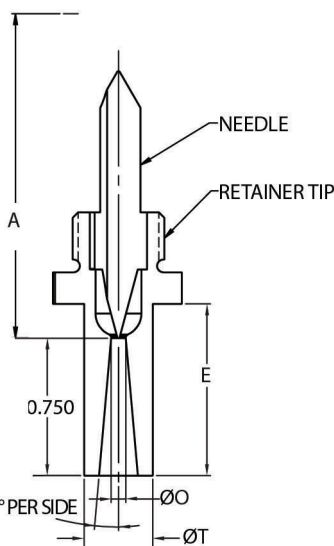

Point Gate (Full Body Extended)

SERIES	TYPE	ITEM NUMBER	T DIA.	O DIA.	E	INCLUDES	
						NEEDLE	RETAINER TIP
250	STANDARD	EHT2301	.375	.060	.938	EHN0015	EHT2326
		EHT2302					EHT2327
		EHT2303					EHT2328
		EHT2304					EHT2329
		EHT2305					EHT2326
	WEAR RESISTANT	EHT2306	EHT2327				
		EHT2307	EHT2328				
		EHT2308	EHT2329				
		EHT2309	EHT2330				
		EHT2310	EHT2331				
375	STANDARD	EHT2311	.500	.100	.980	EHN0016	EHT2332
		EHT2312					EHT2333
		EHT2313					EHT2334
		EHT2314					EHT2335
		EHT2315					EHT2330
	WEAR RESISTANT	EHT2316	EHT2331				
		EHT2317	EHT2332				
		EHT2318	EHT2333				
		EHT2319	EHT2334				
		EHT2320	EHT2335				
625	STANDARD	EHT2321	1.000	.125	1.000	EHN0019	EHT2336
	WEAR RESISTANT	EHT2322				EHN0402	EHT2336

SERIES	THREAD TYPE
250	1/2-24 UN
375	5/8-20 UN
625	1"-16 UN

Housing, Nozzle Plate and Gate Machining Dimensions Detail

Manifold Housing, Nozzle Plate, "A" Plate and Gate Machining Dimensions

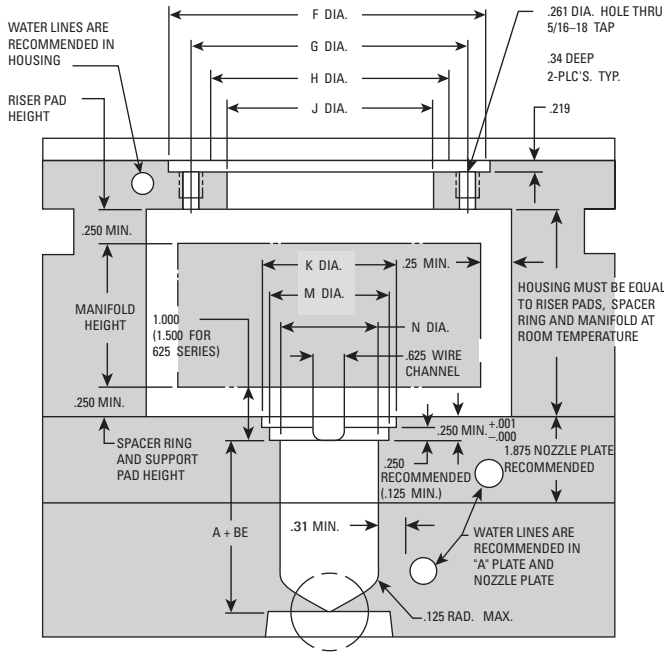

LOCATING RING

ITEM NUMBER	F DIA.	G DIA.	H DIA.	J DIA.
EHL0252	4.000	3.312	3.000	2.500
EHL0253	5.500	4.625	4.000	3.750
EHL0254	4.000	3.312	3.000	2.500
EHL0255	5.500	4.625	4.000	3.750

Manifold housing and insulator sheet are to be same width and length as mold base. Height of manifold housing to vary with stackup of manifold, riser pads and spacer rings.

NOZZLES

SERIES	K DIA.	+0.001 -0.000 M DIA.	N DIA. MIN for SQ. COIL	N DIA. MIN for HIGH PERFORMANCE
250	1.56	1.501	1.062	1.187
375	2.06	2.001	1.250	1.437
625	3.06	3.001	1.875	2.125

NOTE: The expansion factor must be taken into consideration prior to machining for, and installing, nozzle. This expansion factor (BE) must then be added to the nominal "A" dimension.

Formula for determining this expansion factor is as follows:

$$BE = "A" \text{ dimension} \times .00000633 \times \text{nozzle setpoint temp} - 68^\circ (\text{assuming the mold is at } 68^\circ\text{F during operation}). \text{ If mold temperature is different, substitute } 68^\circ\text{F with actual mold temperature.}$$

EXAMPLE: Given a 3 inch "A" dimension, with a nozzle setpoint temp. of 500°:

$$BE = 3 \times .0000063 \times (500 - 68) = .008... \text{ thus } A + BE = 3.008$$

The above information is only given as an example. Variations may occur based on mold configurations and cooling factor. In some instances, it may be necessary to obtain an empirical factor.

SPRUE AND POINT GATE (FULL BODY) MACHINING DIMENSIONS

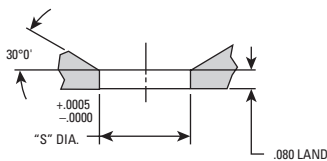

NOTE: Extended sprue length will add .750 to land.

250 & 375 SERIES POINT GATE (BODILESS) MACHINING DIMENSIONS

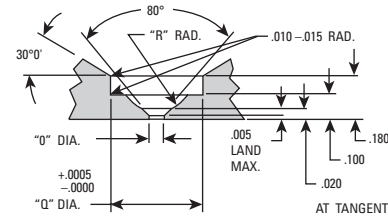

625 SERIES POINT GATE (BODILESS) MACHINING DIMENSIONS

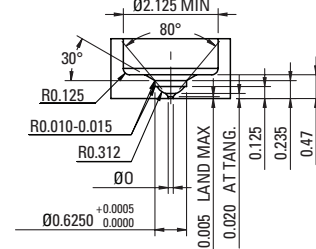

SERIES	T DIA.	S DIA.
250 AND 375	*.375	*.3755
	.500	.5005
	.750	.7505
625	1.000	1.0005

*250 Point Gate (Full Body) only.

SERIES NOZZLE	O DIA.		Q DIA.	R RAD.
	UNFILLED RESIN	FILLED RESIN		
250	.028 MIN.	.060 MIN.	.3750	.125
375	.028 MIN.	.060 MIN.	.5000	.187
625	.080 MIN.	.100 MIN.	.6250	.312

NOTE: The "O" diameter can be opened by the customer to suit the application. Also the land must be remachined to .005 max. after increasing the gate diameter.

Replacement Nozzle Heater Detail

Replacement Square Coil Nozzle Heater

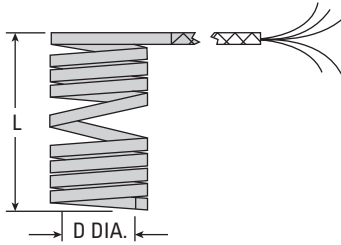

250, 375 AND 625 NOZZLE HEATER 240 VAC, T/C TYPE "J", 36" LONG

WIRING INFORMATION:

- Power leads are black
- Ground lead is green
- Thermocouple leads are black and white
- White is negative (-) and constantan (non-magnetic)
- Black is positive (+) and iron (magnetic)

Replacement High Performance Nozzle Heater

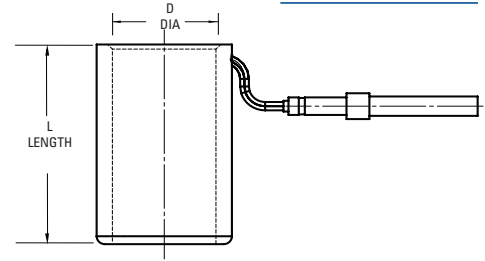

SERIES	ITEM NUMBER	D DIA. NOMINAL NOZZLE	L DIM.	WATTS	USED WITH NOZZLE SUB-ASSEMBLY
250	SCH0081	.625	2.000	300	EHA0001
	SHC1081				EHA1001
	SCH0082		2.500	350	EHA0002
	SCH1082				EHA1002
	SCH0083		3.000	400	EHA0003
	SCH1083				EHA1003
	SCH0084		3.500	425	EHA0004
	SCH1084				EHA1004
	SCH0085		4.000	500	EHA0005
	SCH1085				EHA1005
	SCH0086		5.000	500	EHA0006
	SCH1086				EHA1006
	SCH0087		6.000	550	EHA0007
	SCH1087				EHA1007
375	SCH0088	.875	2.125	400	EHA0008
	SCH1088				EHA1008
	SCH0089		2.625	450	EHA0009
	SCH1089				EHA1009
	SCH0090		3.125	550	EHA0010
	SCH1090				EHA1010
	SCH0091		3.625	700	EHA0011
	SCH1091				EHA1011
	SCH0092		4.125	800	EHA0012
	SCH1092				EHA1012
	SCH0093		5.125	900	EHA0013
	SCH1093				EHA1013
	SCH0094		6.125	1000	EHA0014
	SCH1094				EHA1014
SCH0095	7.125	1100	EHA0015		
SCH1095			EHA1015		
625	SCH0096	1.500	4.000	1000	EHA0016
	SCH1096				EHA1016
	SCH0097		5.000	1030	EHA0017
	SCH1097				EHA1017
	SCH0098		6.000	1100	EHA0018
	SCH1098				EHA1017
	SCH0099		7.000	1000	EHA0019
	SCH1099				EHA1019
	SCH0100		8.000	1200	EHA0020
	SCH1100				EHA1020
	SCH0101		9.000	1200	EHA0021
	SCH1101				EHA1021
	SCH0102		10.000	1200	EHA0022
	SCH1102				EHA1022

SERIES	ITEM NUMBER	D DIA. NOMINAL NOZZLE	L DIM.	WATTS	USED WITH NOZZLE SUB-ASSEMBLY
250	CIH0081S	.625	2.000	440	CIA0001S
	CIH1081S				CIA1001S
	CIH0082S		2.500	350	CIA0002S
	CIH1082S				CIA1002S
	CIH0083S		3.000	400	CIA0003S
	CIH1083S				CIA1003S
	CIH0084S		3.500	565	CIA0004S
	CIH1084S				CIA1004S
	CIH0085S		4.000	500	CIA0005S
	CIH1085S				CIA1005S
	CIH0086S		5.000	500	CIA0006S
	CIH1086S				CIA1006S
	CIH0087S		6.000	550	CIA0007S
	CIH1087S				CIA1007S
375	CIH0088S	.875	2.125	400	CIA0008S
	CIH1088S				CIA1008S
	CIH0089S		2.625	450	CIA0009S
	CIH1089S				CIA1009S
	CIH0090S		3.125	550	CIA0010S
	CIH1090S				CIA1010S
	CIH0091S		3.625	700	CIA0011S
	CIH1091S				CIA1011S
	CIH0092S		4.124	800	CIA0012S
	CIH1092S				CIA1012S
	CIH0093S		5.125	900	CIA0013S
	CIH1093S				CIA1013S
	CIH0094S		6.125	1000	CIA0014S
	CIH1094S				CIA1014S
CIH0095S	7.125	1100	CIA0015S		
CIH1095S			CIA1015S		
625	CIH0104S	1.500	3.038	847	CIA0023S
	CIH1104S				CIA1023S
	CIH0096S		4.038	1000	CIA0016S
	CIH1096S				CIA1016S
	CIH0097S		5.038	1030	CIA0017S
	CIH1097S				CIA1017S
	CIH0098S		6.038	1100	CIA0018S
	CIH1098S				CIA1018S
	CIH0099S		7.038	1000	CIA0019S
	CIH1099S				CIA1019S
	CIH0101S		8.038	1200	CIA0020S
	CIH1101S				CIA1020S
	CIH0102S		9.038	1200	CIA0021S
	CIH1102S				CIA1021S
CIH0103S	10.038	1200	CIA0022S		
CIH1103S			CIA1022S		

Standard Global Manifold Replacement Heaters

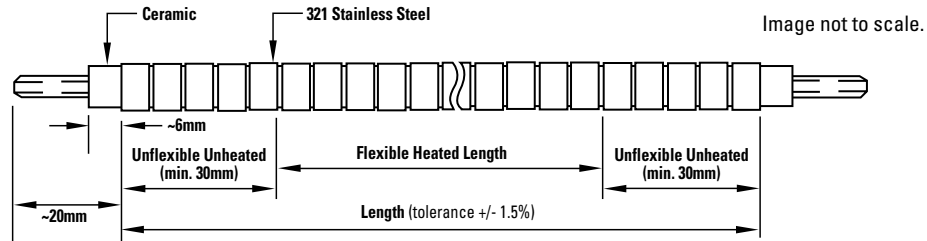

DME Manifold Flexible Replacement Heaters

6.5 & 8.0mm diameter. Operating voltage 230 Volt. Threaded pins on both ends.

6.5MM FLEXIBLE TUBULAR HEATERS		
ITEM NO.	LENGTH (mm)	WATTAGE
HFL650300	300	480
HFL650350	350	480
HFL650400	400	500
HFL650450	450	600
HFL650500	500	700
HFL650550	550	780
HFL650600	600	860
HFL650650	650	950
HFL650700	700	1000
HFL650750	750	1100
HFL650800	800	1100

8.0MM HIGH-WATT FLEXIBLE TUBULAR HEATERS		
ITEM NO.	LENGTH (mm)	WATTAGE
HFH8030	300	605
HFH8035	350	675
HFH8040	400	795
HFH8045	450	910
HFH8050	500	1025
HFH8055	550	1145
HFH8060	600	1260
HFH8065	650	1380
HFH8070	700	1495
HFH8075	750	1615
HFH8080	800	1730
HFH8085	850	1845
HFH8090	900	1960
HFH8095	950	2080
HFH8100	1000	2195
HFH8105	1050	2316
HFH8110	1100	2430
HFH8115	1150	2545
HFH8120	1200	2665
HFH8125	1250	2780
HFH8130	1300	2895
HFH8135	1350	3015
HFH8140	1400	3130
HFH8145	1450	3245
HFH8150	1500	3365

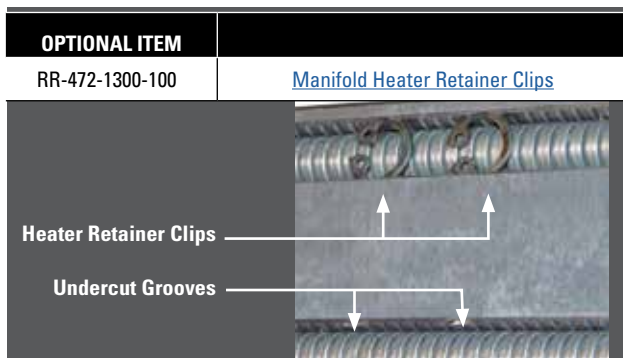

Replacing a DME Manifold Flexible Tubular Heater may also require the replacement of retaining rings that hold the heater in place. After installing the manifold heater, insert a retaining ring into each of the existing undercut grooves in the manifold. Use a brass hammer to lightly tap a small piece of brass and each retaining ring to secure the manifold heater.

Standard Global Manifold Replacement Heaters

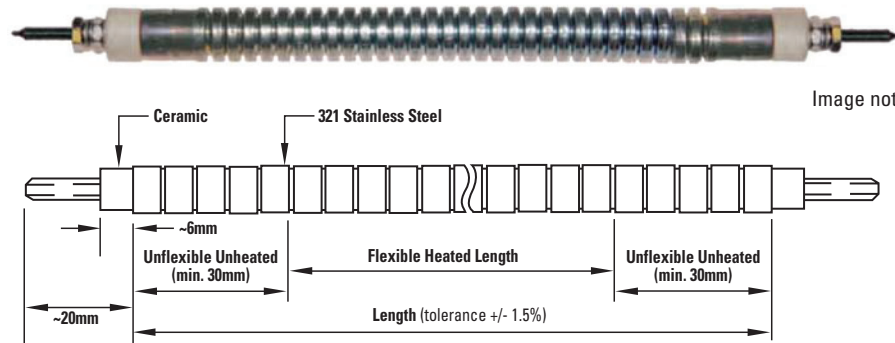

DME Manifold Flexible Replacement Heaters

8.5mm diameter. Operating voltage 230 Volt. Threaded pins on both ends.

HIGH-WATT FLEXIBLE TUBULAR HEATERS		
ITEM NO.	LENGTH (mm)	WATTAGE
HFH850300	300	650
HFH850350	350	750
HFH850400	400	900
HFH850450	450	1050
HFH850500	500	1150
HFH850550	550	1300
HFH850600	600	1450
HFH850650	650	1600
HFH850700	700	1750
HFH850750	750	1900
HFH850800	800	2050
HFH850850	850	2200
HFH850900	900	2350
HFH850950	950	2500
HFH851000	1000	2650
HFH851050	1050	2800
HFH851100	1100	2930
HFH851150	1150	3060
HFH851200	1200	3190
HFH851250	1250	3320
HFH851300	1300	3450
HFH851350	1350	3580
HFH851400	1400	3710
HFH851450	1450	3840
HFH851500	1500	3970

LOW-WATT FLEXIBLE TUBULAR HEATERS		
ITEM NO.	LENGTH (mm)	WATTAGE
HFL850500	500	700
HFL850550	550	780
HFL850600	600	860
HFL850650	650	950
HFL850700	700	1000
HFL850750	750	1100
HFL850800	800	1190
HFL850850	850	1250
HFL850900	900	1350
HFL850950	950	1430
HFL851000	1000	1500
HFL851050	1050	1590
HFL851100	1100	1650
HFL851150	1150	1750
HFL851200	1200	1830
HFL851250	1250	1900
HFL851300	1300	1990
HFL851350	1350	2070
HFL851400	1400	2150
HFL851450	1450	2230
HFL851500	1500	2300

Replacing a DME Manifold Flexible Tubular Heater may also require the replacement of retaining rings that hold the heater in place. After installing the manifold heater, insert a retaining ring into each of the existing undercut grooves in the manifold. Use a brass hammer to lightly tap a small piece of brass and each retaining ring to secure the manifold heater.

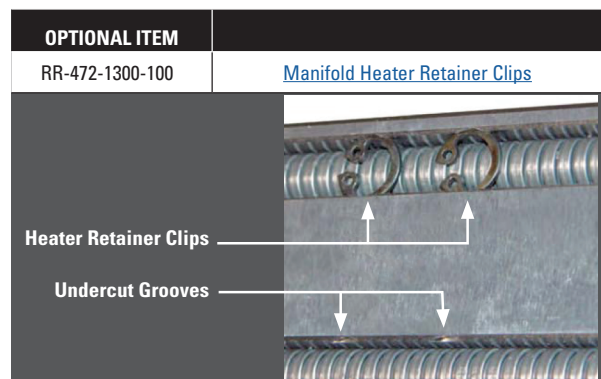

Replacement Parts Detail

Terminal Mounting Box

For information on terminal mounting boxes, mold power and thermocouple connectors, see the DME Control Systems Catalog.

Nozzle Seat

Replaceable interface between manifold and machine nozzle.

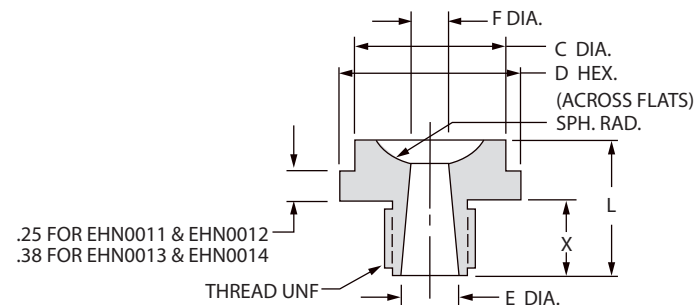

ITEM NUMBER	SPH. RAD.	X	L	C DIM.	D HEX.	E DIA.	F DIA.	THREAD
EHN0011	.500	.62	1.250	1.250	1.50	.363	.312	3/4-16
EHN0012	.750							
EHN0013	.500	.75	1.750	1.500	1.88	.457	.375	1-12
EHN0014	.750							

Locating Ring

INCLUDES (2) 5/16 - 18 x 1/2" LG. FLAT HEAD CAP SCREWS

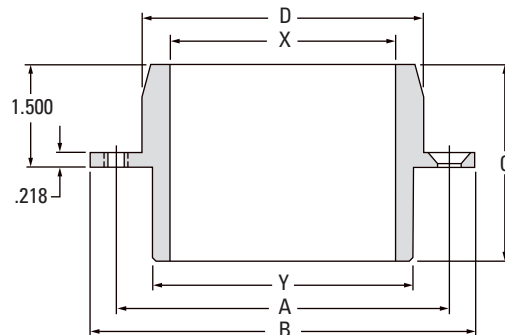

ITEM NUMBER	D DIA.	X DIA.	Y DIA.	A DIM.	B DIA.	C DIM.
EHL0252	2.990	2.000	2.500	3.312	3.990	2.875
EHL0253	3.990	3.250	3.750	4.625	5.495	2.875
EHL0254	2.990	2.000	2.500	3.312	3.990	4.500
EHL0255	3.990	3.250	3.750	4.625	5.495	4.500

Nozzle Seat Machining

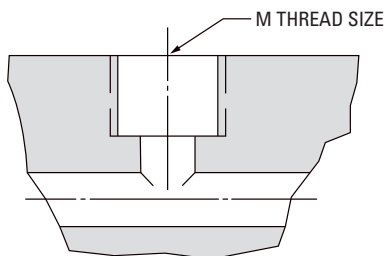

ITEM NUMBER	M THREAD SIZE
EHN0011	.687 DIA. HOLE x .56 DEEP
EHN0012	3/4-16 UNF TAP x .50 DEEP
EHN0013	.922 DIA. HOLE x .69 DEEP
EHN0014	1-12 UNF TAP x .62 DEEP

Locating Ring Machining

Relief in top of manifold for locating ring.

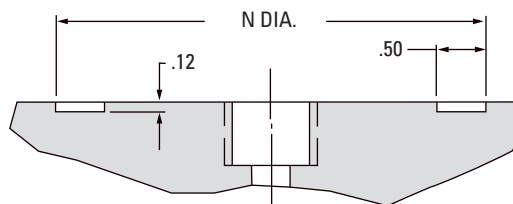

ITEM NUMBER	N DIA. ^{+0.005} / _{-.000}
EHL0252	2.505
EHL0253	3.755
EHL0254	2.505
EHL0255	3.755

Drool Rings

Used in conjunction with nozzle seat and locating ring to prevent nozzle purging and drooling from entering manifold area.

ITEM NUMBER	B DIA.	C DIA.
EHL1001	1.38	2.19
EHL1002	1.62	
EHL1003	1.38	3.44
EHL1004	1.62	

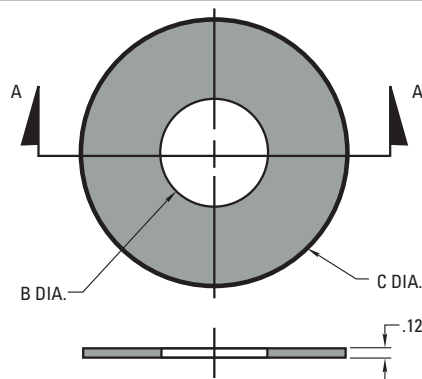
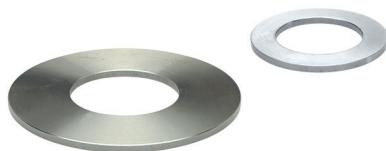

See application information on the preceding page for appropriate use of nozzle seats, drool rings and locating rings.

Components for Externally Heated Manifold Systems

Used primarily with tubular heated manifolds, these components are made from a non-magnetic material with low thermal conductivity. They provide the higher efficiency and performance required for tubular manifold applications.

Riser Pads

Supports manifold opposite nozzles and prevents heat loss.

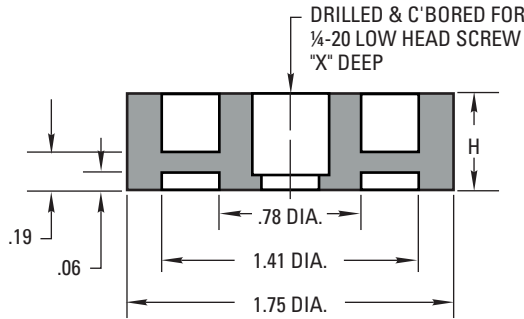
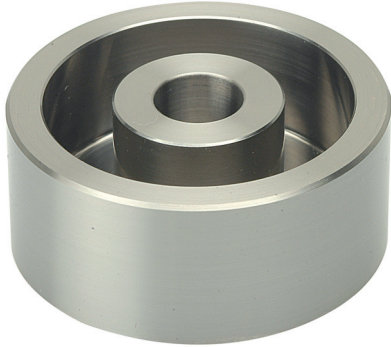

ITEM NUMBER	H	X
ERP1001	.500	.405
ERP1002	.750	.655

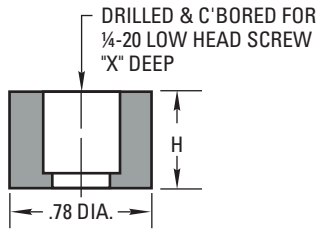

ITEM NUMBER	H	X
ERP1011	.500	.405
ERP1012	.750	.655

Center Support Pads and Tubular Dowels

Supports manifold center spacing, while minimizing heat transfer from manifold.

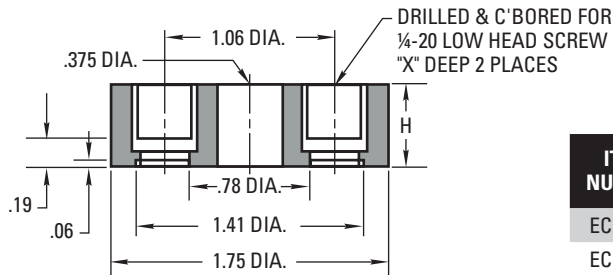

ITEM NUMBER	H	X
ECB1001	.500	.405
ECB1002	.750	.655

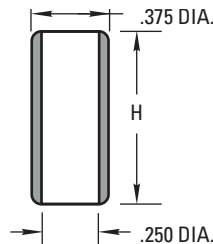

ITEM NUMBER	L LENGTH
3834TD	.750
38114TD	1.250

Parts Detail

Riser Pad

Supports manifold opposite nozzles. Prevents heat loss and maintains spacing between manifold and clamping plate.

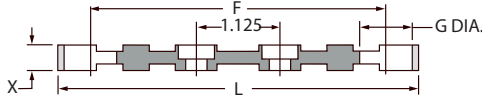

INCLUDES (2) #10-24 LOW HEAD CAP SCREWS

ITEM NUMBER	X DIM. ⁺⁰¹⁰ / _{-.000}	L DIM.	F DIM.	G DIA.	USED WITH
ERP0163	.250				GATE-MATE 4, 250 SERIES AND 375 SERIES
ERP0167	.375	4.000	3.250	.625	
ERP0164	.750				
ERP0165	.250				
ERP0168	.375	5.000	4.000	.781	625 SERIES
ERP0166	.750				

Center Support Pad

Aligns and supports manifold center while minimizing heat transfer from manifold.

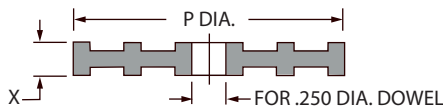

ITEM NUMBER	X DIM. ⁺⁰¹⁰ / _{-.000}	P DIA.
ECB0161	.250	2.500
ECB0162	.750	2.500
ECB0163	.250	1.500
ECB0164	.750	1.500

Spacer Ring

Maintains spacing between manifold and nozzle plate.

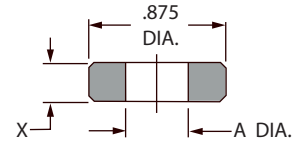

ITEM NUMBER	X DIM. ⁺⁰¹⁰ / _{-.000}	A DIA.	USED WITH
ESR0157	.250	.406	GATE-MATE 4, 250 SERIES AND 375 SERIES
ESR0158	.750	.406	
ESR0159	.250	.531	625 SERIES
ESR0160	.750	.531	

Tapered Dowel Pin

Aligns and prevents end plug from rotating. Tapered dowel pin must conform to ANSI B18.8.2-1978 standard.

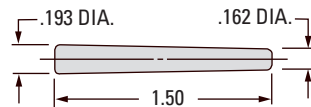

ITEM NUMBER
EDP0001

End Plug

Used to plug horizontal flow channels.

Material : P-20

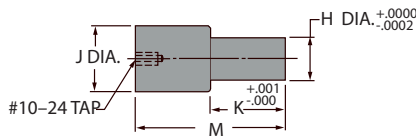

SERIES	ITEM NUMBER	H DIA.	J DIA.	K DIM.	M DIM.
GATE-MATE 4	EEP0002	.5615	.800	.750	1.500
250	EEP0001	.4365	.675	.750	1.500
375	EEP0002	.5615	.800	.750	1.500
625	EEP0003	.6875	.894	1.125	1.875

End Plug Set Screw

Used to secure end plug into manifold (2 required). End plug set screw must conform to the following standards. ANSI B1.1. ANSI B18.3 and ASTM F912.

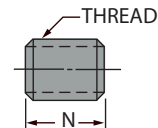

SERIES	ITEM NUMBER	THREAD	N DIM.
GATE-MATE 4	SSS7878	7/8-14 UNF-3A	.875
250	SSS3434	3/4-16 UNF-3A	.750
375	SSS7878	7/8-14 UNF-3A	.875
625	SSS11	1-12 UNF-3A	1.000

Heater Stop Machining

Used for ECH-Series cartridge heaters.

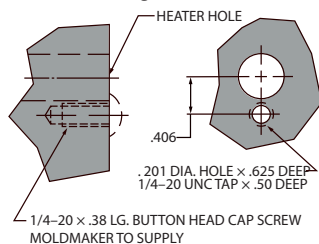

Heater Puller Machining

Used for CHS-Series cartridge heaters recommended for heaters installed in blind holes.

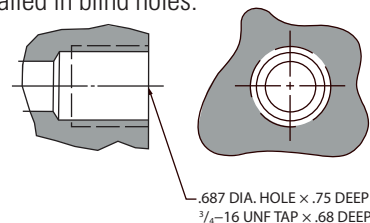

Cartridge Heaters & Thermocouples

240 VAC, 36" Leads with 6" of Lead Protection

Cartridge Heater – Power Leads are multi-colored



Shoulder Style Cartridge Heater

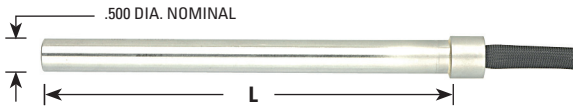

Although these heaters do not employ integral thermocouples, they're designed and constructed to run at higher molding temperatures and provide longer life than conventional heaters.

Cartridge Heaters

.500 DIAMETER NOMINAL			
ITEM NUMBER	LENGTH L	WATTS	WATTS PER LIN. IN.
ECH0103	4.0	500	125
ECH0119	4.0	750	188
ECH0104	4.5	575	128
* ECH0138	5.0	500	100
ECH0105	5.0	650	130
* ECH0139	5.0	750	150
ECH0120	5.0	1000	200
* ECH0148	5.5	500	91
ECH0106	5.5	725	132
* ECH0140	6.0	750	125
ECH0107	6.0	800	133
ECH0121	6.0	1000	167
ECH0108	6.5	875	135
* ECH0141	7.0	600	86
ECH0109	7.0	950	136
ECH0122	7.0	1000	143
* ECH0149	7.5	1000	133
ECH0110	7.5	1025	137
* ECH0142	8.0	1000	125
ECH0111	8.0	1100	138
ECH0123	8.0	1500	188
ECH0124	8.0	2000	250
ECH0112	8.5	1175	138
ECH0113	9.0	1200	133
ECH0114	10.0	1350	135
ECH0125	10.0	1500	150
ECH0126	11.0	1000	91
ECH0115	11.0	1500	136
ECH0128	12.0	1000	83
ECH0127	12.0	1500	125
ECH0116	12.0	1650	137
* ECH0144	12.0	2000	167
* ECH0146	14.0	1000	71
* ECH0145	14.0	2300	164
ECH0129	15.0	1500	100
ECH0117	15.0	2050	137
* ECH0147	18.0	1500	83
ECH0130	18.0	1700	94
ECH0118	18.0	2500	139

Cartridge Heaters

Can be installed through hole or installed using retainer plate construction.

Shoulder Style Cartridge Heaters

These heaters are used in conjunction with heater pullers to insure easy removal of blind or through hole installations.

Shoulder Style Cartridge Heaters

ITEM NUMBER	L IN INCHES	WATTS	WATTS PER LIN. IN.
CHS0119	4.0	500	125
CHS0120	4.5	575	128
CHS0121	5.0	650	130
CHS0122	5.5	725	132
CHS0123	6.0	800	133
CHS0124	6.5	875	135
CHS0125	7.0	950	136
CHS0126	7.5	1025	137
CHS0127	8.0	1100	138
CHS0128	8.5	1175	138
CHS0129	9.0	1200	133
CHS0130	10.0	1350	135
CHS0131	11.0	1500	136
CHS0132	12.0	1650	137
CHS0133	15.0	2050	137
CHS0134	18.0	2500	139

Heater puller to be ordered separately.

Heater Puller (with Snap Ring)

Provides trouble-free removal of Shoulder Style Cartridge Heater.

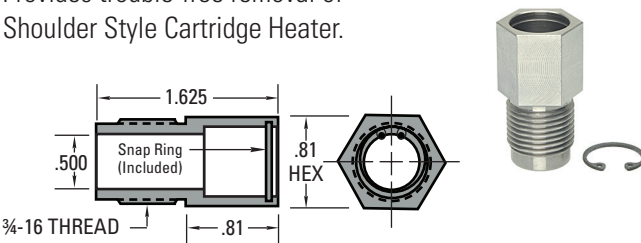

PULLER WITH RING

ITEM NUMBER

EHP0250

REPLACEMENT SNAP RINGS

ITEM NUMBER*

EHP0001

*Pkg. of 25

Manifold Thermocouples

Installed in manifold to maintain precise temperature control.

Flat Washer Type

Utilized in limited space applications.



**OBSELETE
NO LONGER AVAILABLE**

USE # 60J723

Threaded Type

Installed between heat source and flow channel for more precise control.

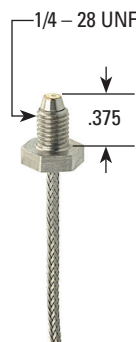

ITEM NUMBER

ETC0251

NOTE: Sizes preceded by an * are the newest additions.

See the Hot One Design and Machining Guidelines at the end of this Hot One Nozzles section for manifold size recommendation and installation drawings.

Cartridge Heaters

Cartridge Heaters - CU



DME Standard Cartridge heaters employ a swaged construction using the finest resistance wire and insulation available for optimum heating performance, long life and maximum dependability. These heaters are furnished with 10" long flexible lead wires, ready for fast installation. Thermocouple cartridge heaters are also available.

NOTE: Lead wires can withstand temperatures up to 450°F. If temperatures will exceed this amount, leads must be insulated.

DIA.	LENGTH (INCHES)	VOLTS	WATTS	ITEM NUMBER
1/4	2	120	40	CU2021
	2	240	40	CU2022
	3	120	75	CU2031
	3	240	75	CU2032
	4	120	100	CU2041
	4	240	100	CU2042
	6	120	150	CU2061
	6	240	150	CU2062
3/8	2	120	75	CU3021
	2	240	75	CU3022
	3	120	100	CU3031
	3	240	100	CU3032
	4	120	150	CU3041
	4	240	150	CU3042
	5	120	185	CU3051
	5	240	185	CU3052
	6	120	225	CU3061
	6	240	225	CU3062
	8	120	300	CU3081
	8	240	300	CU3082
1/2	2	120	75	CU4021
	2	240	75	CU4022
	3	120	150	CU4031
	3	240	150	CU4032
	4	120	180	CU4041
	4	240	180	CU4042
	5	120	200	CU4051
	5	240	200	CU4052
	6	120	300	CU4061
	6	240	300	CU4062
	8	120	400	CU4081
	8	240	400	CU4082
	10	120	500	CU4101
	10	240	500	CU4102
	12	120	600	CU4121
	12	240	600	CU4122
	16	120	800	CU4161
	16	240	800	CU4162

DIA.	LENGTH (INCHES)	VOLTS	WATTS	ITEM NUMBER
5/8	2	120	100	CU5021
	2	240	100	CU5022
	3	240	200	CU5032
	4	240	250	CU5042
	5	120	300	CU5051
	5	240	300	CU5052
	6	120	375	CU5061
	6	240	375	CU5062
	8	120	500	CU5081
	8	240	500	CU5082
	10	120	650	CU5101
	10	240	650	CU5102
	12	120	775	CU5121
	12	240	775	CU5122
	14	240	900	CU5142
	16	240	1050	CU5162
3/4	3	240	225	CU6032
	4	120	300	CU6041
	4	240	300	CU6042
	5	120	375	CU6051
	5	240	375	CU6052
	6	120	450	CU6061
	6	240	450	CU6062
	8	120	600	CU6081
	8	240	600	CU6082
	10	120	800	CU6101
	10	240	800	CU6102
	12	120	950	CU6121
12	240	950	CU6122	
14	240	1100	CU6142	
16	240	1250	CU6162	

NOTE: Special heaters are available on special order.

High Watt Density Cartridge Heaters



Fit Tolerances

The cavity or hole, into which a cartridge heater is inserted, should be reamed* to the nominal diameter of the heater. DME cartridge heater diameters are actually .002 to .007 undersize. High Watt Density Cartridge Heaters are .004 undersize, held to a tolerance of $\pm .002$. This sizing is maintained for easy installation and for best heat transfer. However, if close hole tolerances are not maintained, operating life of the heater may be drastically reduced. Also make sure that the heated area of the cartridge does not extend beyond the hole.

Spacing of Heaters

As a general rule it is not recommended to space heaters in a mold, die or platen any closer to each other than the diameter of the heater.

Contamination

Contamination consists of any foreign matter such as plastics, oil, grease, dirt or water entering through the terminal end or the end opposite the terminal. Care must be taken to protect the heater or these contaminants will shorten the effective heater life.

Proper Care and Maintenance

1. Heaters should be stored in a dry area, especially during periods of excess humidity.
2. Protect leads from abuse, abrasion, fatigue, etc.
3. Maintain temperature controllers and accessories in good working condition to avoid an overheating condition.
4. Transferring heaters from one die or platen to another is not recommended.

DME High Watt Density Cartridge Heaters employ swaged construction for maximum heat transfer and high watt density for more demanding applications. Recommended for use when high temperatures are required (up to 1500°F) or where heaters will be subjected to vibration. Furnished with 10" long flexible lead wires. Special heaters are available on special order. Thermocouple cartridge heaters are also available.

DIA.	LENGTH (INCHES)	VOLTS	WATTS	ITEM NUMBER
1/4	1	120	100	CM1001
	1	240	100	CM1002
	1 1/2	120	150	CM1121
	1 1/2	240	150	CM1122
	2	120	200	CM2021
	2	240	200	CM2022
	3	120	300	CM2031
	3	240	300	CM2032
	4	240	375	CM2042
3/8	5	240	450	CM2052
	2	240	250	CM3022
	3	240	350	CM3032
	4	240	500	CM3042
	5	240	550	CM3052
1/2	6	240	600	CM3062
	2	240	250	CM4022
	3	240	300	CM4032
	4	240	400	CM4042
	5	240	800	CM4052
	6	240	1000	CM4062
	8	240	1200	CM4082
5/8	10	240	1500	CM4102
	12	240	2000	CM4122
	2	240	300	CM5022
	4	240	700	CM5042
	6	240	1000	CM5062
	8	240	1200	CM5082
	9	240	1400	CM5092
3/4	10	240	1500	CM5102
	14	240	2000	CM5142
	2	240	300	CM6022
	4	240	750	CM6042
	6	240	1200	CM6062
	10	240	1600	CM6102
	14	240	2200	CM6142

*See DME Equipment and Supplies Catalog for DME machine reamers and DME straight shank long drills.

NOTE: Lead wires can withstand temperatures up to 450°F. If temperatures will exceed this amount, leads must be insulated.

Nozzle Heaters for Injection Molds



Features

- Square coil design for improved heat transfer
- High watt density on nozzle ... up to 106 watts/in²
- Heat is conducted from entire heater circumference ... 360° heat
- Unheated tail section reduces temperature at adapter
- Moisture-resistant seal
- Low profile
- 1200°F maximum operating temperature
- Available for same-day shipping

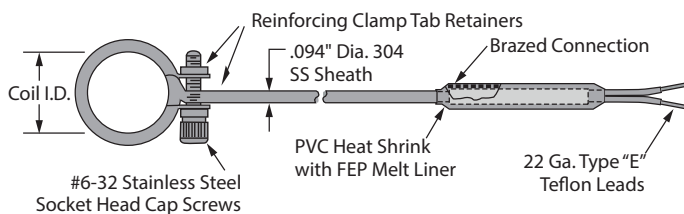
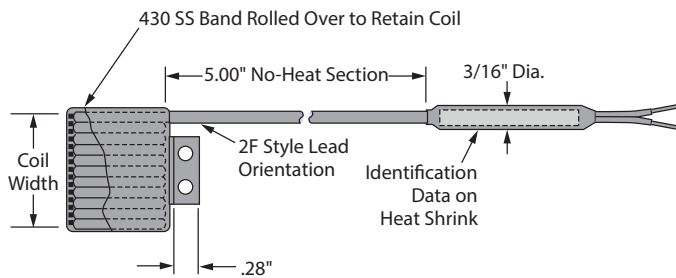

Nozzle Heaters (240 VAC)

WATTS	COIL I.D.	COIL O.D.	COIL WIDTH	LEAD LENGTH	THERMO-COUPLE	ITEM NUMBER
125	.750	.980	1.0"	36"	NO	SCH0103
125	.750	.980	1.0"	72"	NO	SCH0104
250	.750	.980	1.0"	36"	NO	SCH0105
250	.750	.980	1.0"	72"	NO	SCH0106
125	.750	.980	1.0"	36"	YES*	SCH0107
250	.750	.980	1.0"	36"	YES*	SCH0108
125	.875	1.10	1.0"	36"	NO	SCH0109
250	.875	1.10	1.0"	36"	NO	SCH0110

*A thermocouple is externally spotwelded to the sheath.

This nozzle heater features a five-inch long unheated tail section, and the adapter is provided with a moisture-resistant seal. These two design advantages practically eliminate failures in the adapter area due to overheating and moisture contamination.

As with all DME heaters, these new nozzle heaters are designed to give long life even when operated at 1200°F. These are very low profile heaters to facilitate easy installation in the tight environment of multiple gate molds.

All units have a resistance tolerance of $\pm 5\%$ to provide consistent operation and reduced adjustment time when it is necessary to replace a heater or bushing.

A stainless steel clamping band is installed on all units.

All units are stock coiled per the dimensions listed below. All units have Teflon® covered power leads and fiberglass thermocouple leads as indicated.

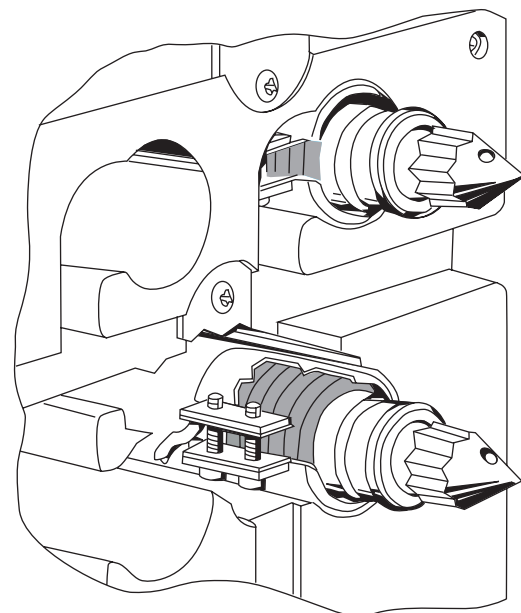

This installation illustrates DME's square coil design fit over a nozzle. This heater was designed to fit any industry nozzle as a replacement for runnerless molding.

High Watt Density Thermocouple Cartridge Heaters



DME High Watt Density Thermocouple Cartridge Heaters employ swaged construction for maximum heat transfer and high watt density for more demanding applications. Recommended for use when high temperatures are required (up to 1500°F) or where heaters will be subjected to vibration.

Fit Tolerances

The cavity or hole into which a cartridge heater is inserted should be reamed* to the nominal diameter of the heater. DME cartridge heater diameters are actually .002 to .007 undersize. High Watt Density Cartridge Heaters are .003 undersize, held to a tolerance of ±.002. This sizing is maintained for easy installation and for best heat transfer. However, if close hole tolerances are not maintained, operating life of the heater may be drastically reduced. Also make sure that the heated area of the cartridge does not extend beyond the hole.

Contamination

Contamination consists of any foreign matter such as plastics, oil, grease, dirt or water entering through the terminal end or the end opposite the terminal. Care must be taken to protect the heater or these contaminants will shorten the effective heater life.

Proper Care and Maintenance

1. Heaters should be stored in a dry area, especially during periods of excess humidity.
2. Protect leads from abuse, abrasion, fatigue, etc.
3. Maintain temperature controllers and accessories in good working condition to avoid an overheating condition.
4. Transferring heaters from one die or platen to another is not recommended.

*See DME Equipment and Supplies Catalog for DME machine reamers and DME straight shank long drills.

These diagrams show typical installations of a thermocouple replacement cartridge heater.

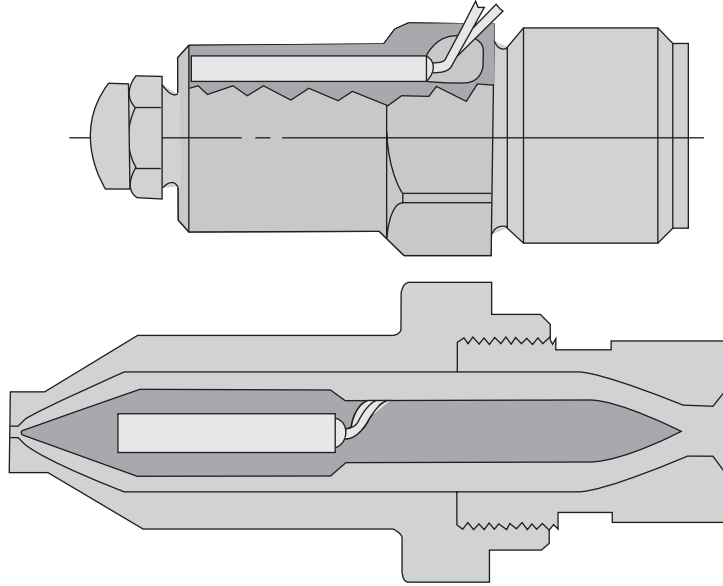

High Watt Density Thermocouple Cartridge Heaters (240 VAC, Type J Thermocouple, 36" Long Leads)

DIAMETER	LENGTHS		VOLTS	WATTS	ITEM NUMBER
	IN	CM			
3/8" (9.42mm)	1 3/4	4.445	240	200	TCH0001
	2	5.08	240	250	TCH0002
	2 1/2	6.35	240	250	TCH0003
	3	7.52	240	250	TCH0004
	3 1/2	8.39	240	320	TCH0005
	4	10.15	240	370	TCH0006
	4 1/2	11.43	240	420	TCH0007
	5	12.70	240	470	TCH0008
	5 1/2	13.97	240	525	TCH0009
	6	15.24	240	575	TCH0010
	6 1/2	16.51	240	625	TCH0011
1/2" (12.50mm)	7	17.78	240	675	TCH0012
	7 1/2	19.05	240	725	TCH0013
	8	20.32	240	775	TCH0014
	3 1/2	8.89	240	420	TCH0015
	4	10.16	240	480	TCH0016
	4 1/2	11.43	240	550	TCH0017
	5	12.70	240	625	TCH0018
	5 1/2	13.97	240	700	TCH0019
	6	15.24	240	775	TCH0020
	6 1/2	16.51	240	850	TCH0021
	7 1/2	19.05	240	975	TCH0022

Thermocouples



DME Bayonet Thermocouples are made of 20 gauge stranded glass-insulated wires. The grounded hot junction is in the end of a .188 O.D. stainless steel protecting tube for fast response and long life. Tube features a round tip and is fitted with a stainless steel spring loaded bayonet fitting. Lead wires are protected by rugged .188 I.D. flexible armor (lead wire calibration is ANSI Type J Iron/Constantan). Armor cable is 47" long; spade lugs are attached at the end of the lead wires for easy connection to terminal strip or plug.

DME Adjustable Bayonet Type Thermocouples fit hole depths up to $10\frac{1}{2}$ " and will conform to any angle.

DME Spade Type Thermocouples are used between band heaters and machine nozzles in applications where space will not permit bayonet-type thermocouples. The stainless steel spade is only .025 thick and can be easily contoured to fit various diameters.

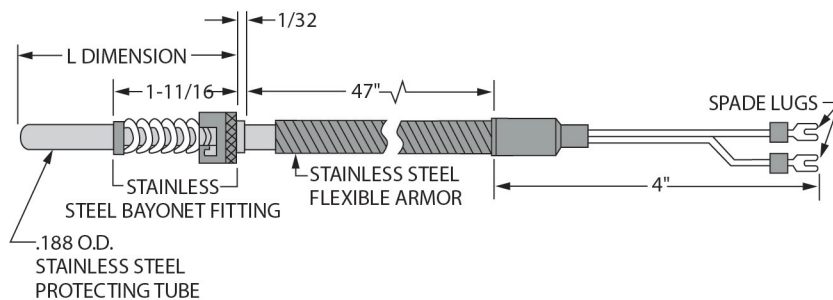

Straight Type

ITEM NUMBER	L
TC2500	2 1/2
TC3500	3 1/2
TC6000	6"

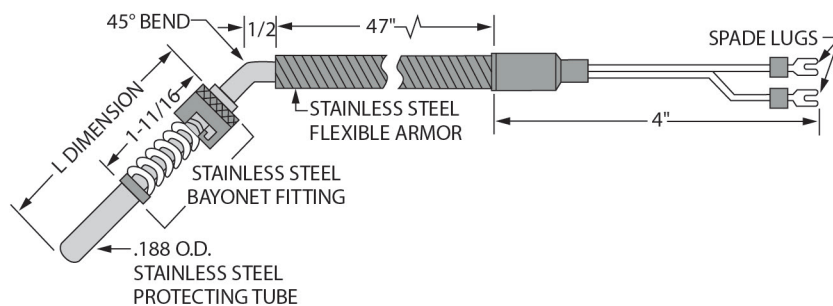

45° Angle Type

ITEM NUMBER	L
TC2545	2 1/2
TC3545	3 1/2

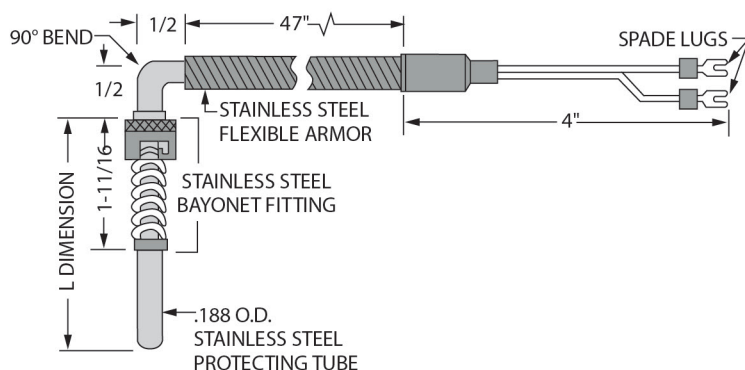

90° Angle Type

ITEM NUMBER	L
TC2590	2 1/2
TC3590	3 1/2
TC6090	6"

Thermocouples and Accessories

Hole Depth Chart

L THERMOCOUPLE LENGTH	A HOLE DEPTH FOR ADAPTER LENGTH	
	7/8	1 3/8
2 1/2	1" TO 1 3/8	1/2 TO 7/8
3 1/2	2" TO 2 3/8	1 1/2 TO 1 7/8
6"	4 1/2 TO 4 7/8	4" TO 4 3/8
10 1/2 ADJ.	1/2 TO 10 1/2	1/2 TO 10"

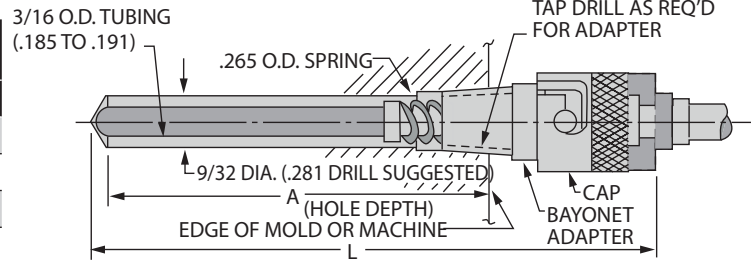

Adjustable Thermocouple

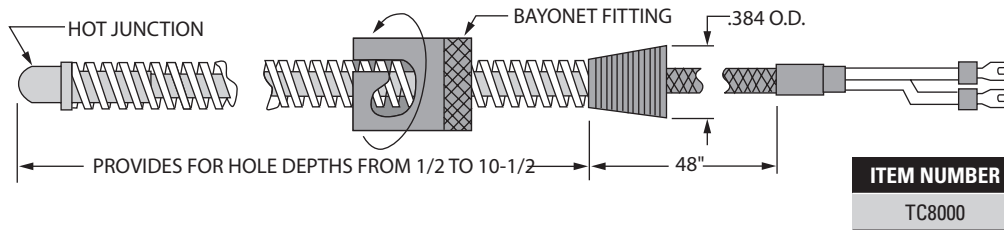

By turning the adjustable bayonet fitting along the spring, the DME Adjustable Thermocouple can be set for the desired immersion length, from 1/2" to 10 1/2". Spring will conform to any angle. Hot junction of ANSI Type J I/C calibrated leads is inside round tip. Flexible metal braid is 48" long with 2 1/2" of lead wires at the end and spade lugs for ease of connection.

ITEM NUMBER
TC8000

Threaded Type Thermocouple

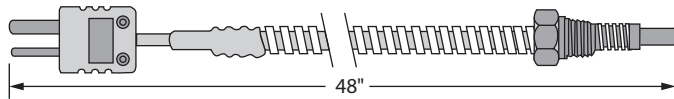

ITEM NUMBER
TCT4

Threaded type thermocouple is spring loaded and supplied with cable and mini plug.

Bayonet Adapters

The stainless steel bayonet adapters accommodate the spring loaded bayonet fitting on the thermocouple, to bottom the hot junction where temperature sensing is desired. Adapter requires tapped hole for mounting.

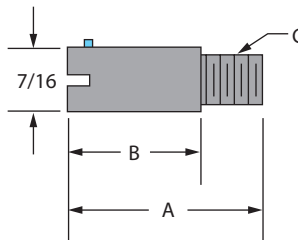

ITEM NUMBER	A	B	C
BA1007	7/8	.465	1/8-27 NPT
BA1013	1 3/8	.934	1/8-27 NPT
BA4007	7/8	.465	3/8-24 NF
BA4013	1 3/8	.934	3/8-24 NF

Spade Type Thermocouple

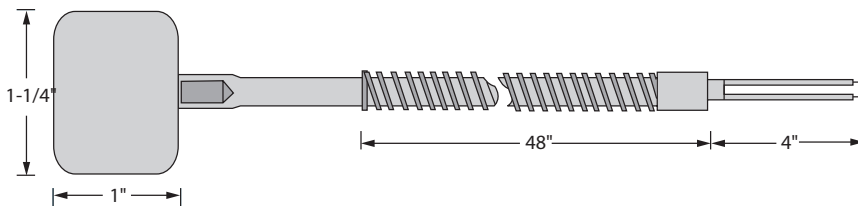

Used between band heaters and machine nozzles in applications where space will not permit bayonet type thermocouples. Stainless steel spade measures 1" x 1 1/4" x .025 thick and can be easily contoured to fit various diameters.

ITEM NUMBER
TC9000

Thermocouple is Type J I/C. Flexible stainless steel armor cable is 48" long with 4" of lead wires at the end.

Plug (with Cable Clamp)

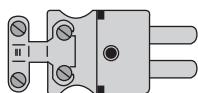

ITEM NUMBER
PL10

ROUND PINS AND SOCKETS (3/16 & 1/8)

Jack (with Cable Clamp)

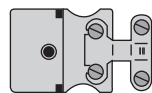

ITEM NUMBER
PL20

Mini Plug

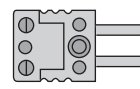

ITEM NUMBER
M2MJ

FLAT PINS AND SOCKETS

Mini Jack

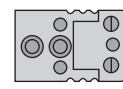

ITEM NUMBER
M2FJ

DME Meteor® Hot Runner Systems

CUSTOM-CONFIGURED,
ECONOMICAL SOLUTIONS
FOR QUICK DELIVERY

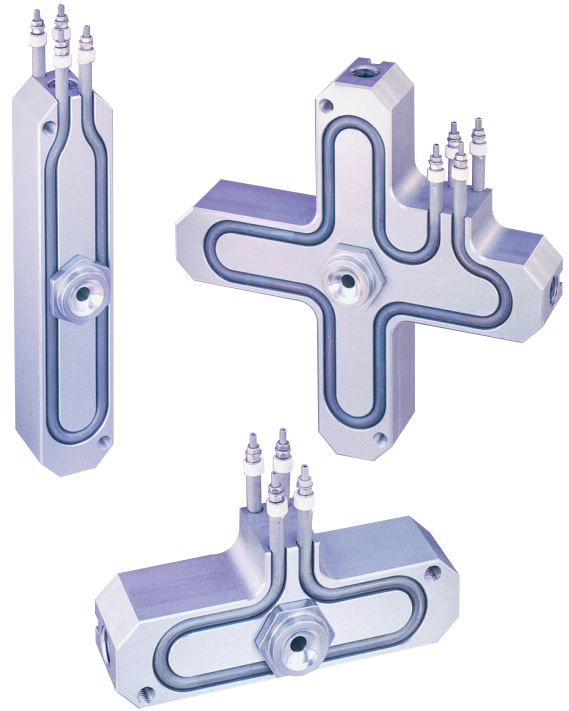

More Solutions. More Choices. Always Quick Delivery.

The Meteor Package

Each Meteor manifold kit includes the following standard items:

- Manifold with pre-machined horizontal flow channel
- Pre-installed, replaceable tubular heaters
- End plugs
- End plug set screws

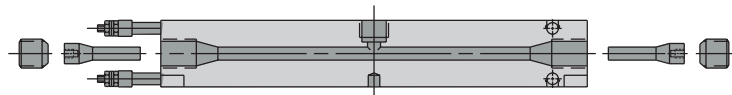

Ancillary Components

A variety of ancillary components available include:

- Locating rings
- Drool rings
- Nozzle seats
- Riser pads and cap screws
- Center support pads and dowel pins
- Thermocouples

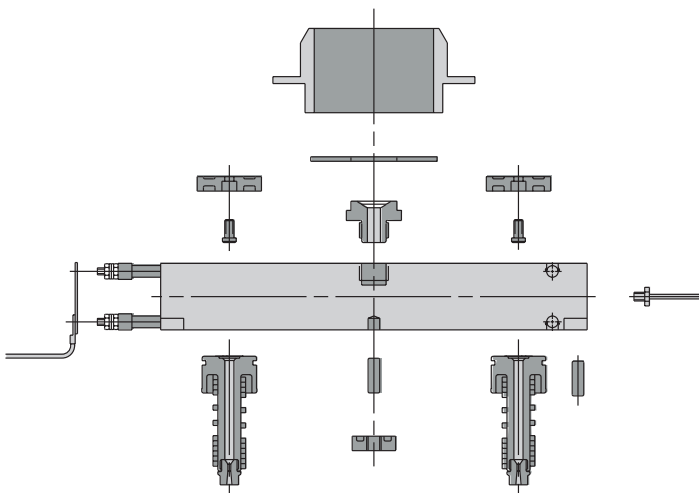

Nozzle Options

All nozzles have a selection of tip styles to suit material flow and gate cosmetic requirements.

METEOR SYSTEM	EHA AND CIA	
	250 SERIES	375 SERIES
METEOR 1	X	X
METEOR 2	X	X

Application Notes

- 250 Series nozzles to be used with manifold kits MEM0100K thru MEM0200K, MCM0100K thru MCM0200K and MXM0100K thru MXM0200K. 375 Series nozzles to be used with all other manifold kits.
- All manifolds with suffix of 100K, 150K and 200K have a 9mm diameter flow channel; all other manifolds have a 12mm diameter flow channel.
- CIA High Performance nozzles are recommended for materials that process above 260°C/500°F.
- For filled or abrasive materials, wear-resistant tips are recommended.
- Meteor manifolds are not recommended for use with PVC material.
- Contact DME for assistance.

More Solutions. More Choices.



Meteor 1 manifold

Meteor manifolds are supplied with replaceable, press-fit tubular heaters.

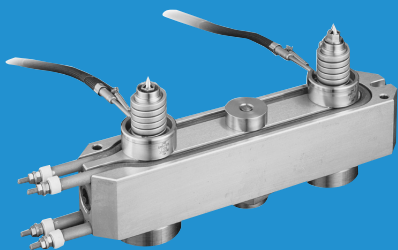

Meteor 2 manifold and components

The Meteor® Manifold System provides a versatile yet economical solution for many hot runner mold designs. Two-drop (in-line) and four-drop (X-style) manifolds are available in sizes to suit a variety of applications. Pre-engineered with accurately machined flow channels, nozzle ports can be freely located anywhere within each manifold's flow channel limits. Meteor manifolds are supplied with replaceable, press-fit tubular heaters which are stocked for quick delivery. A full complement of ancillary components are also available to complete the system design and construction.

Advantages

- Two levels of quick-delivery hot runner systems
- In-line and X-style manifolds for 2- and 4-drop applications
- Suitable for engineered and commodity resins
- Cost-effective
- Satisfaction 100% guaranteed

Choose the Meteor System that's right for you

DME offers two quick-delivery hot runner systems with varying levels of customization – you pick the one that fits your needs.

Meteor 1

- Standardized manifolds with machined horizontal flow channel
- Customer machines vertical flow channel locations and end plugs for maximum configuration flexibility
- Customer can easily order a Meteor 1 manifold kit and select nozzles, supports, nozzle seat, locating ring, thermocouples and other necessary items

Meteor 2

- Manifold and components system, integrated with a Meteor 1 manifold kit
- Customer specifies nozzles, supports, nozzle seat, locating ring, thermocouples, etc.
- DME performs vertical flow channel and end plug machining

Meteor 1 In-Line and X-Style Manifolds

Meteor 1

Meteor 1 In-Line End Exit

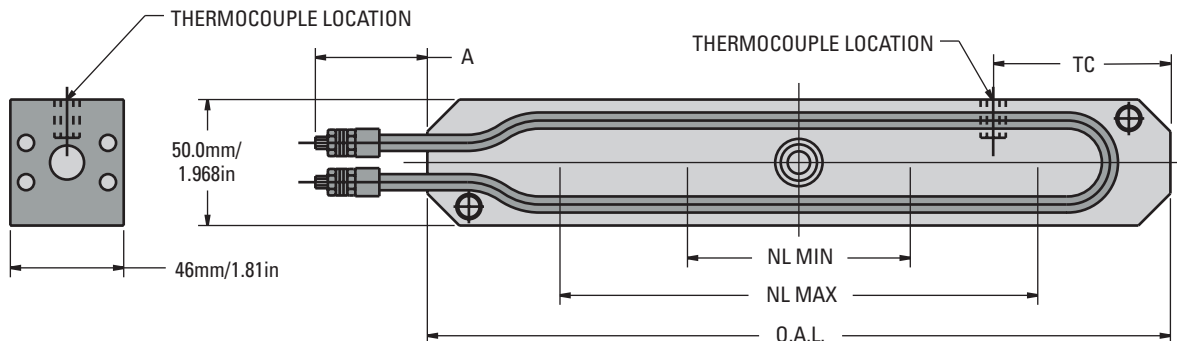

Meteor 1 In-Line Center Exit

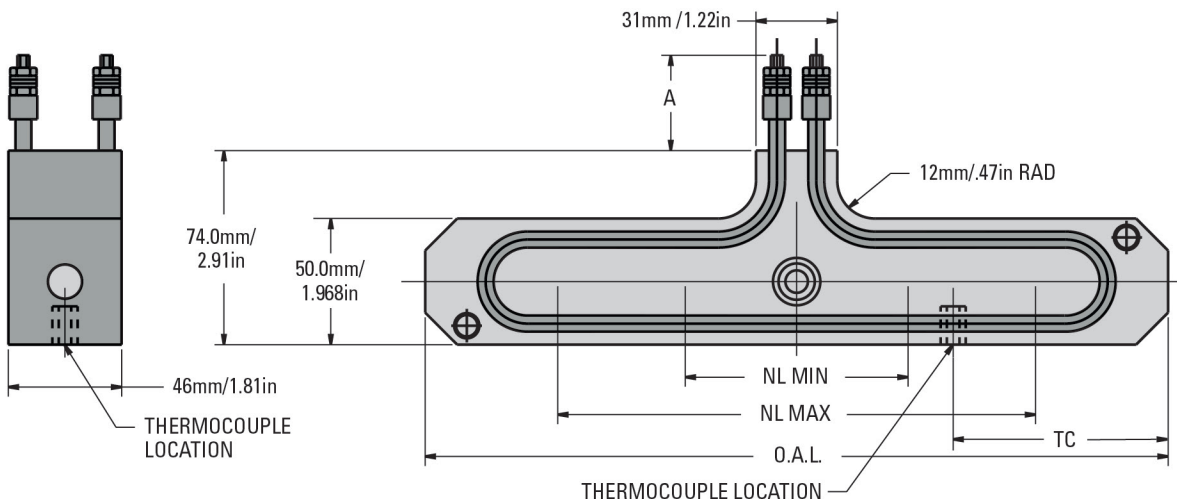

Meteor Systems

MANIFOLD TYPE	MANIFOLD KIT ITEM NO.	NL MIN.		NL MAX.		O.A.L.		A		B		TC	
		MM	INCH	MM	INCH	MM	INCH	MM	INCH	MM	INCH	MM	INCH
IN-LINE END EXIT	MEM0100K	55	2.165	100	3.937	195	7.677	44.5	1.75	—	—	60	2.362
	MEM0150K	100	3.937	150	5.906	245	9.646	44.5	1.75	—	—		
	MEM0200K	150	5.906	200	7.874	295	11.614	44.5	1.75	—	—		
	MEM0300K	200	7.874	300	11.811	395	15.551	44.5	1.75	—	—	72.5	2.362
	MEM0400K	300	11.811	400	15.748	495	19.488	50.8	2.00	—	—		
MEM0500K	400	15.748	500	19.685	595	23.425	50.8	2.00	—	—			
IN-LINE CENTER EXIT	MCM0100K	55	2.165	100	3.937	195	7.677	44.5	1.75	—	—	60	2.362
	MCM0150K	100	3.937	150	5.906	245	9.646	44.5	1.75	—	—		
	MCM0200K	150	5.906	200	7.874	295	11.614	44.5	1.75	—	—		
	MCM0300K	200	7.874	300	11.811	395	15.551	44.5	1.75	—	—	72.5	2.854
	MCM0400K	300	11.811	400	15.748	495	19.488	50.8	2.00	—	—		
	MCM0500K	400	15.748	500	19.685	595	23.425	50.8	2.00	—	—		
X-STYLE	MXM0100K	55	2.165	100	3.937	195	7.677	44.5	1.75	56.8	2.236	SEE X-STYLE	
	MXM0150K	100	3.937	150	5.906	245	9.646	44.5	1.75	51.3	2.020	60	2.362
	MXM0200K	150	5.906	200	7.874	295	11.614	50.8	2.00	51.3	2.020		
	MXCM0300K	200	7.874	300	11.811	395	15.551	50.8	2.00	51.3	2.020	72.5	2.854

Meteor 1 In-Line and X-Style Manifolds

Meteor 1 X-Style

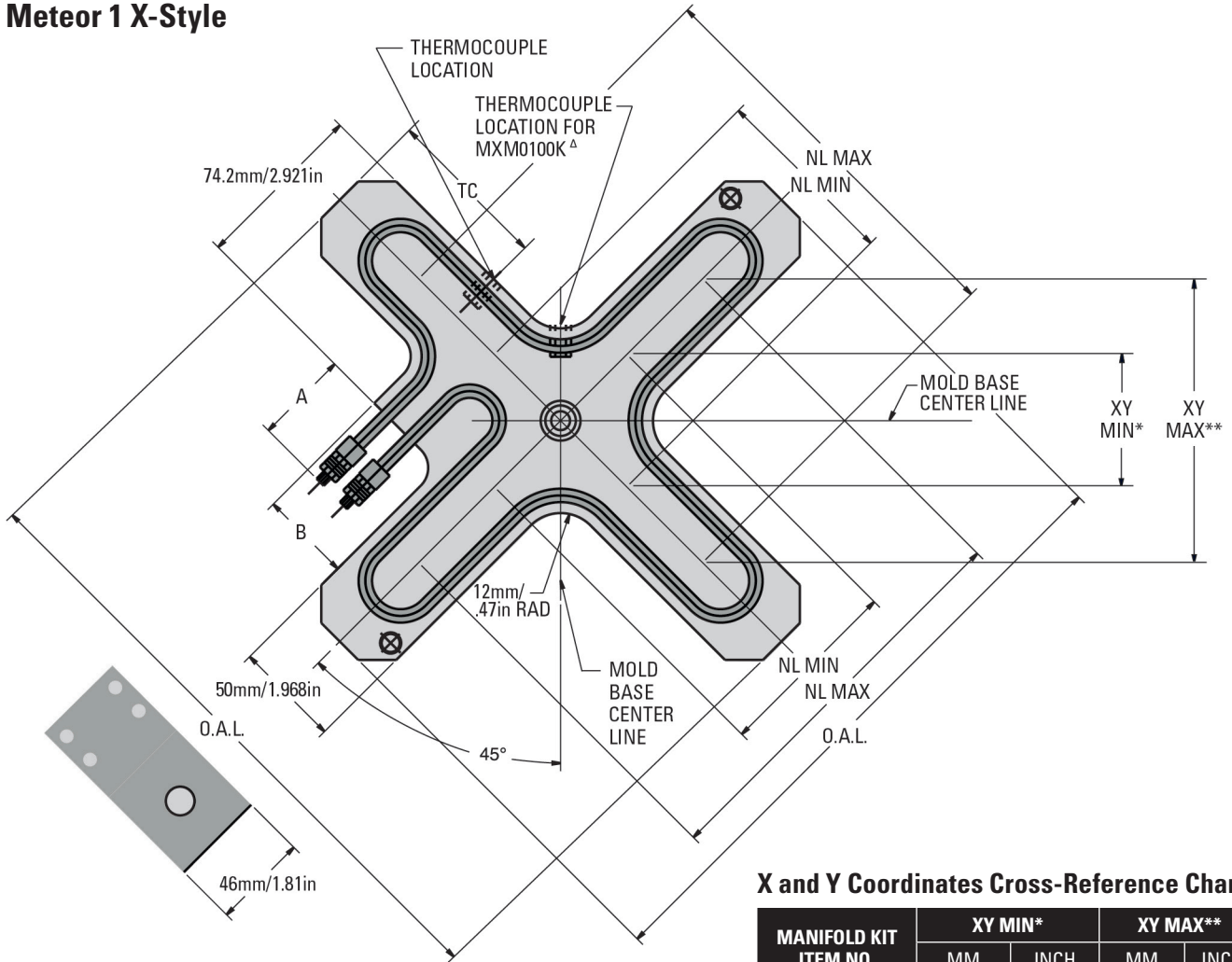

X and Y Coordinates Cross-Reference Chart

MANIFOLD KIT ITEM NO.	XY MIN*		XY MAX**	
	MM	INCH	MM	INCH
MXM0100K	38.90	1.531	70.71	2.783
MXM0150K	70.71	2.783	106.07	4.176
MXM0200K	106.07	4.176	141.42	5.568
MXM0300K	141.42	5.568	212.13	8.352

Meteor 1 Manifold Kit Includes:

In-Line System:

- (1) Manifold (center or end heater exit)
- (2) Tubular heaters (installed)
- (2) Tapered end plugs
- (2) Set screws

X-Style System:

- (1) Manifold
- (2) Tubular heaters (installed)
- (4) Tapered end plugs
- (4) Set screws

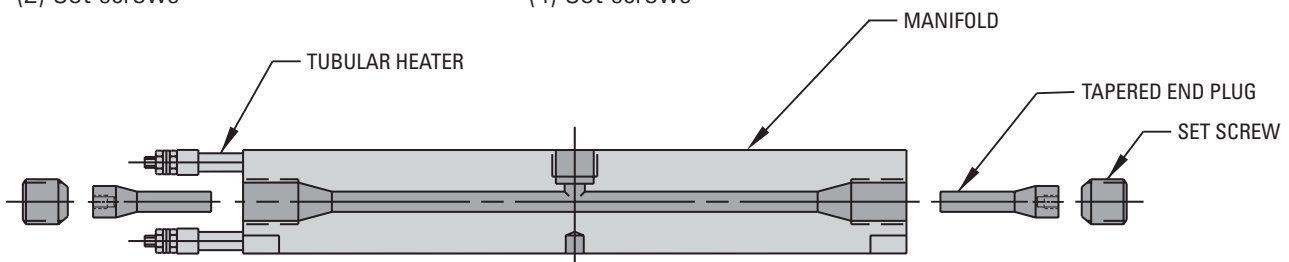

Meteor 1 & 2 Ancillary Component Options

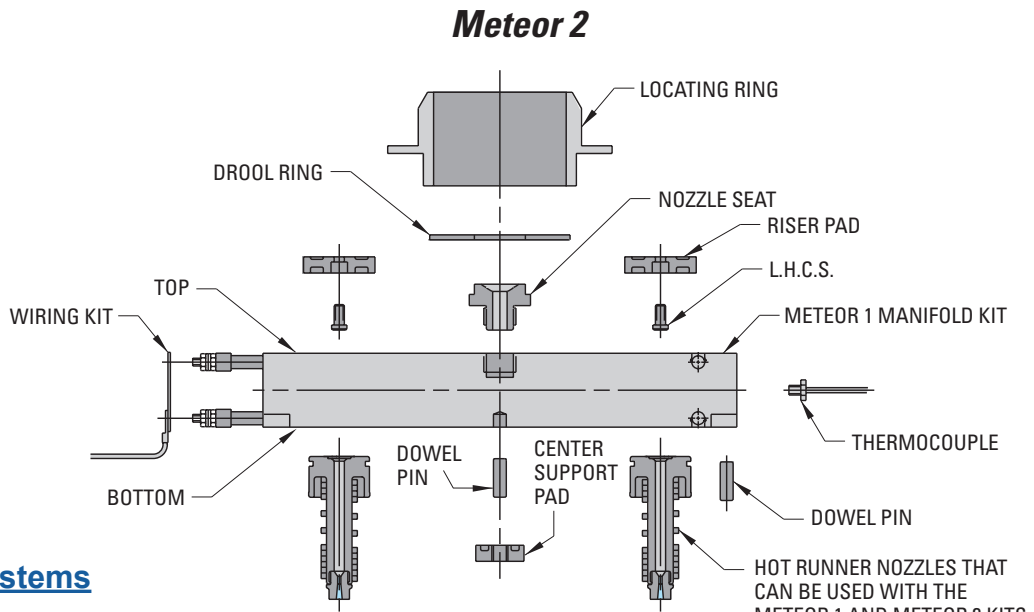

Meteor Systems

MANIFOLD TYPE	METEOR 1 MANIFOLD KIT ITEM NO.	METEOR 2 MANIFOLD KIT PLUS ITEM NO.	DESIGN CRITERIA		
			NOZZLE OPTIONS	V VERTICAL FLOW CHANNEL DIA.	
				MM	INCH
IN-LINE END EXIT	MEM0100K	MEM0100KP	250, EHA & CIA SERIES	9	.354
	MEM0150K	MEM0150KP			
	MEM0200K	MEM0200KP			
	MEM0300K	MEM0300KP			
	MEM0400K	MEM0400KP			
IN-LINE CENTER EXIT	MEM0500K	MEM0500KP	375, EHA & CIA SERIES	12	.472
	MCM0100K	MCM0100KP			
	MCM0150K	MCM0150KP			
	MCM0200K	MCM0200KP			
	MCM0300K	MCM0300KP			
X-STYLE	MCM0400K	MCM0400KP	250, EHA & CIA SERIES	9	.354
	MCM0500K	MCM0500KP			
	MXM0100K	MXM0100KP			
	MXM0150K	MXM0150KP			
	MXM0200K	MXM0200KP			
	MXM0300K	MXM0300KP	375, EHA & CIA SERIES	12	.472

Meteor 1 Manifold Kit includes manifold, tubular heaters installed, two end plugs, and two set screws. The customer machines the vertical flow channel locations and end plugs for maximum configuration flexibility.

Meteor 2 Manifold Kit Plus includes the machining of the vertical flow channels and the installation of the end plugs and set screws by DME.

The customer provides DME with the gate locations on a Meteor 2 Criteria Form.

MANIFOLD TYPE	METEOR 1 MANIFOLD KIT ITEM NO.	METEOR 2 MANIFOLD KIT PLUS ITEM NO.	ANCILLARY COMPONENT OPTIONS								
			THERMO-COUPLE ITEM NO.	LOCATING RING ITEM NO.	DROOL RING ITEM NO.	NOZZLE SEAT ITEM NO.	RISER PADS ITEM NO.	CTR. SUPPORT PADS ITEM NO.	DOWEL PINS ITEM NO.	1/4-20 X .50 LG. L.H.C.S. ITEM NO.	WIRING KIT ITEM NO.
IN-LINE END EXIT	MEM0100K	MEM0100KP	ETC0252	EHL0253 EHL0255 (1 REQ'D.)	EHL1003	MNS0009	ERP1001 ERP1002 ERP1011 ERP1012 (2 OF SAME REQ'D.)	ECB0468 ECB0469 ECB0503 (1 REQ'D.)	DP820 DP828 DP832 (2 OF SAME REQ'D.)	1412LH (2 REQ'D.)	MWK1001
	MEM0150K	MEM0150KP									
	MEM0200K	MEM0200KP									
	MEM0300K	MEM0300KP									
	MEM0400K	MEM0400KP									
	MEM0500K	MEM0500KP	ETC0252 (2 REQ'D.)			MNS0012					MWK1002
IN-LINE CENTER EXIT	MCM0100K	MCM0100KP	ETC0252	EHL0253 EHL0255 (1 REQ'D.)	EHL1003	MNS0009	ERP1001 ERP1002 ERP1011 ERP1012 (2 OF SAME REQ'D.)	ECB0468 ECB0469 ECB0503 (1 REQ'D.)	DP820 DP828 DP832 (2 OF SAME REQ'D.)	1412LH (2 REQ'D.)	MWK1001
	MCM0150K	MCM0150KP									
	MCM0200K	MCM0200KP									
	MCM0300K	MCM0300KP									
	MCM0400K	MCM0400KP									
	MCM0500K	MCM0500KP	ETC0252 (2 REQ'D.)			MNS0012					MWK1002
X-STYLE	MXM0100K	MXM0100KP	ETC0252	EHL0253 EHL0255 (1 REQ'D.)	EHL1003	MNS0009	ERP1001 ERP1002 ERP1011 ERP1012 (4 OF SAME REQ'D.)	ECB0468 ECB0469 ECB0503 (1 REQ'D.)	DP820 DP828 DP832 (2 OF SAME REQ'D.)	1412LH (2 REQ'D.)	MWK1001
	MXM0150K	MXM0150KP									
	MXM0200K	MXM0200KP									
	MXM0300K	MXM0300KP									

Meteor 1 & 2 Ancillary Component Options

Locating Rings

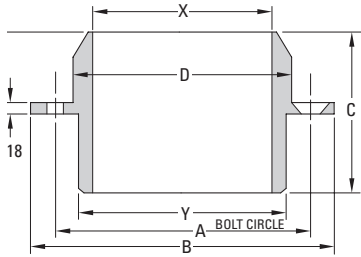

ITEM NO.	Ø D	Ø X	Ø Y	A	Ø B	C
EHL0253	101 MM 3.990 IN	82.5 MM 3.250 IN	95 MM 3.750 IN	117 MM 4.625 IN	139.5 MM 5.495 IN	73 MM 2.875 IN
EHL0255	101 MM 3.990 IN	82.5 MM 3.250 IN	95 MM 3.750 IN	117 MM 4.625 IN	139.5 MM 5.495 IN	114 MM 4.500 IN

Includes (2) 1/2 inch long, 5/16 Flat Head Cap Screws.

Center Support Pads

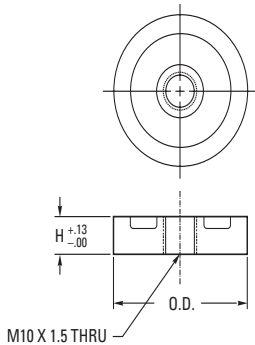

ITEM NO.	O.D.		H	
	MM	IN	MM	IN
ECB0468	30	1.181	20	.787
ECB0469	30	1.181	10	.394
ECB0503	40	1.575	10	.394

NOTES:

1. The M10 X 1.5 tapped hole is used to screw the center support pad to a plate for machining the pad to the correct height.
2. An 8mm dia. dowel pin is required for assembly.

Drool Ring

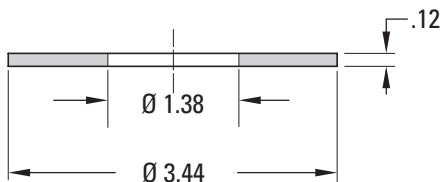

ITEM NO.
EHL1003

Machine Nozzle Seats

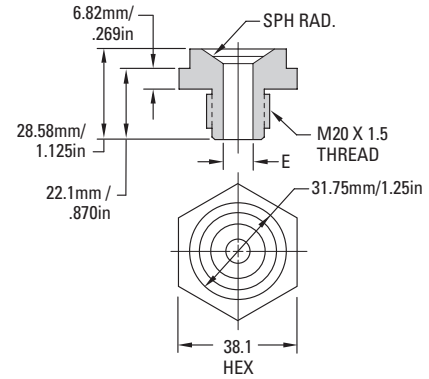

ITEM NO.	E FLOW CHANNEL		SPHERICAL RADIUS
	MM	IN	
MNS0009	9 MM	.354 IN	1/2 + 3/4 IN
MNS1009	9 MM	.354 IN	15.5 MM
MNS0012	12 MM	.472 IN	1/2 + 3/4 IN
MNS1012	12 MM	.472 IN	15.5 MM

NOTE: Machine nozzle tip orifice to be matched properly with nozzle seat flow channel.

Dowel Pins

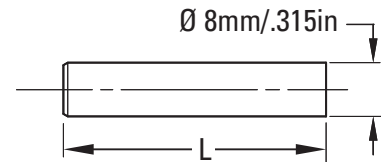

ITEM NO.	L	
	MM	IN
DP820	20	.787
DP828	28	1.102
DP832	32	1.260

Manifold Thermocouple

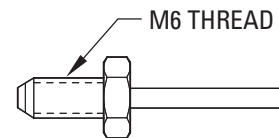

ITEM NO.
ETC0252

Meteor 1 & 2 Ancillary Component Options

Riser Pads and Screws

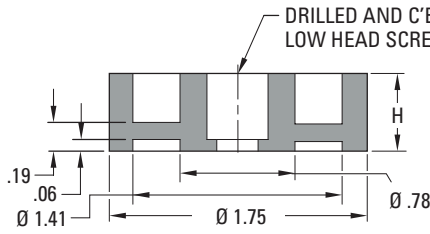

ITEM NO.
1412LH

1/4-20 x 1/2 lg. LOW HEAD CAP SCREW (L.H.C.S.)

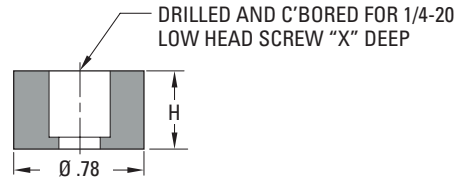

ITEM NO.	H		X	
	MM	IN	MM	IN
ERP1001	12.7	.500	10	.405
ERP1002	19	.750	16.6	.655

ITEM NO.	H		X	
	MM	IN	MM	IN
ERP1011	12.7	.500	10	.405
ERP1012	19	.750	16.6	.655

NOTE: For maximum support, use riser pads ERP1001 or ERP1002 whenever possible. Only use riser pads ERP1011 or ERP1012 when there are space constraints.

Meteor Spare Parts

MANIFOLD TYPE	MANIFOLD KIT ITEM NO.	TUBULAR HEATER		END PLUG ITEM NO.	SET SCREW ITEM NO.
		ITEM NO.	WATTAGE		
IN-LINE END EXIT	MEM0100K	MEH0100	600	MTP0009	MSS0001
	MEM150K	MEH0150	750		
	MEM0200K	MEH0200	900		
	MEM0300K	MEH0300	1225	MPT0012	
	MEM0400K	MEH0400	1550		
MEM0500K	MEH0500	1850			
IN-LINE CENTER EXIT	MCM0100K	MCH0100	600	MTP0009	
	MCM0150K	MCH0150	750		
	MCM0200K	MCH0200	900		
	MCM0300K	MCH0300	1225	MPT0012	
	MCM0400K	MCH0400	1550		
MCM0500K	MCH0500	1850			
X-STYLE	MXM0100K	MXH0100	575	MPT0009	
	MXM0150K	MXH0150	1350		
	MXM0200K	MXH0200	1675	MPT0012	
	MXM0300K	MXH0300	2150		

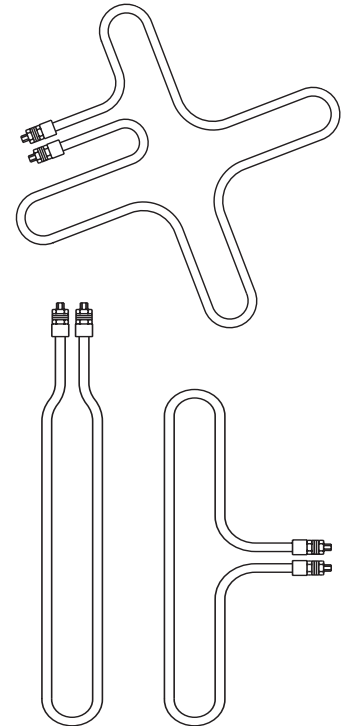

End Plugs

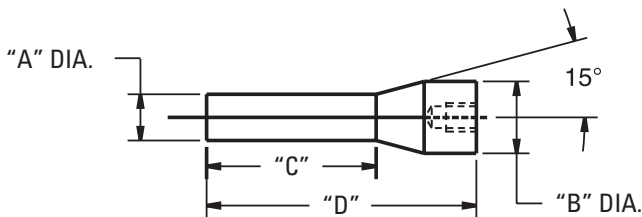

ITEM NO.	A		B		C		D	
	MM	IN	MM	IN	MM	IN	MM	IN
MTP0009	9	.354	14	.551	33	1.299	52.5	2.067
MTP0012	12	.472	16	.630	60	2.362	77.5	3.051

Set Screw

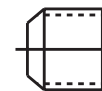

- Thread: M20 x 2.5
- Thickness: 20MM (.787IN)
- Hex flat: 10MM (.394IN)

DME Hot Sprue Bushings

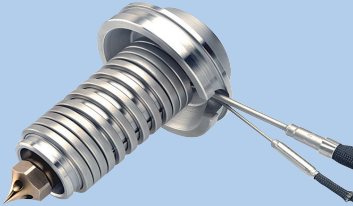

Table of Contents



D-MAX High Performance Hot Sprue Bushings..... 63-69

Capability with engineered and commodity-grade resins



Gate-Mate® Hot Sprue Bushings 70-77

Ideal for direct part gating, single-cavity molds



Straight Shot® Hot Sprue Bushings 78-88

Reduce cycle times and save material costs



Integally Heated Hot Sprue Bushings.....89-94

Advanced heat transfer capability promotes a more uniform heat profile

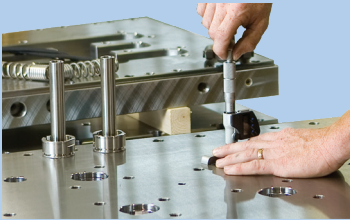

Hot Runner Services.....95-100

Total support for your hot runner systems



Obsolete Replacement Parts101-111

Obsolete replacement parts for hot runner systems and nozzles

D-MAX High Performance Hot Sprue Bushings

HIGH-PERFORMANCE CAPABILITY
WITH ENGINEERED AND
COMMODITY-GRADE RESINS



Plastic Materials and Specifications

- Large number of bushing and tip combinations
- Three flow channel sizes
- Lengths up to 190mm
- High performance capability
- Standard and wear-resistant tips
- Precise thermal control

PLASTIC MATERIAL PROCESS CONDITIONS

MATERIAL	STANDARD RESIN SYMBOL	PROCESS TEMPERATURE		MOLD TEMPERATURE		HOT RUNNER TEMPERATURE		DENSITY MELTING		SOLID DENSITY	
		[°C]	[°F]	[°C]	[°F]	[°C]	[°F]	[g/cm ³]	[lbs/inch ³]	[g/cm ³]	[lbs/inch ³]
Styrene Butadiene	SB	210	410	70	158	230	446	0.93	0.0366	1.02	0.0369
Polyurethane	PUR	220	428	45	113	240	464	0.93	0.0366	1.11	0.0401
Styrene-acrylonitrile	SAN	230	446	80	176	255	491	0.99	0.0358	1.08	0.0390
Polystyrene	PS	210	410	45	113	230	446	0.95	0.0343	1.05	0.0379
Polycarbonate	PC	300	572	80	176	330	626	1.08	0.0390	1.20	0.0434
Polyphenylene Oxide-Styrene	PPO	260	500	80	176	300	572	0.99	0.0358	1.13	0.0408
Polyethylene	PE	200	392	25	77	225	437	0.74	0.0267	0.96	0.0347
Polypropylene	PP	225	437	40	104	245	473	0.73	0.0264	0.91	0.0329
Polyether-etherketone	PEEK	330	626	165	329	370	698	1.13	0.0408	1.37	0.0495
Polyphenylene Sulfide	PPS	300	572	110	230	330	626	1.53	0.0553	1.70	0.0614
Polybutylene Terephthalate	PBT	265	509	60	140	290	554	1.44	0.0520	1.57	0.0567
Polyamide 6	PA 6	220	428	90	194	250	482	0.98	0.0354	1.14	0.0412
Polyamide 66	PA 66	255	491	90	194	280	536	1.09	0.0394	1.26	0.0455
Thermal Plastic Elastomers	TPE	240	464	35	95	265	509	0.78	0.0282	0.90	0.0325
Polyoxymethylene (Polyacetal)	POM	180	356	100	212	200	392	1.16	0.0419	1.42	0.0513
Polymethyl Methacrylate	PMMA	235	455	70	158	250	482	1.09	0.0394	1.18	0.0426
Acrylonitrile Butadiene Styrene	ABS	225	437	70	158	250	482	0.95	0.0343	1.08	0.0390

NOTE: Temperature and density values shown above are general, and may not apply to your application. Please refer to proper processing data for the resin grade intended for your specific application. Failure to use temperature settings appropriate to the specific resin and resin grade intended for your application may result in poor part quality, or inability to produce acceptable molded parts.

High Performance Hot Sprue Bushing 250 Series

NOTE: Dimensions shown in inches unless specified otherwise.

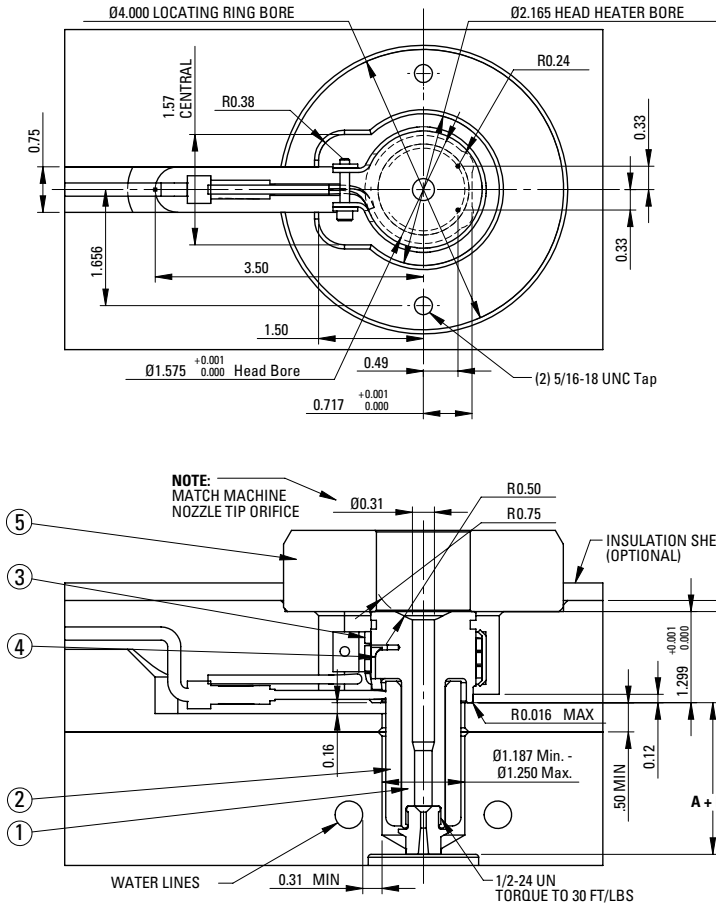

High Performance Hot Sprue Bushing - 250 Series

For selection of gate diameter it is important to take into consideration the material flow characteristics, share rate of resin, molding conditions, fill time requirements, gate vestige, wall thickness and configuration of parts to be molded. Situations requiring high injection velocities must be considered when selecting small gate diameters. High injection rates may require larger gates due to shear heat build up (e.g. high weight thin wall applications). See material manufacturer's literature for further information regarding material to be molded.

To compensate for nozzle's growth when heat is applied, the linear expansion of the nozzle (BE) at a given temperature must be added to the nominal "A" dimension. The formula below shows how to figure boring depth (dimension "A" + BE). The tip of the nozzle will now be flush with the cavity line at processing temperature.

Formula for determining this expansion factor is as follows:
 $BE = \text{"A" dimension} \times 0.00000633 \times \text{nozzle set point} - 68^{\circ}F$
 (assuming the mold is at 68°F during operation). If mold temperature is different, substitute 68°F with actual mold temperature.

EXAMPLE: Given a 4.134 inch "A" dimension, with a set point of 500°F:

$$BE = 4.134 \times 0.00000633 \times (500 - 68) = 0.011$$

Thus "A" + BE will be 4.145

NOTE: The above information is only given as an example; variations may occur based on mold configurations and cooling factor. In some instances, it may be necessary to obtain an empirical factor.

"O" DIA.		"S" DIA.
UNFILLED RESIN	FILLED RESIN	
0.028 Min.	0.062 Min.	*0.3750
		0.5005
		0.7505
		1.0005

* Point Gate (Full Body) only.

BUSHING AND COMPONENT SPECIFICATIONS							
ASSEMBLY	"A" DIMENSION	ASSEMBLY COMPONENTS					
		BUSHING BODY DETAIL #1	HIGH PERFORMANCE HEATER DETAIL #2	WATTAGE	HEAD HEATER DETAIL #3	WATTAGE	THERMOCOUPLE DETAIL #4
DMAX06055	2.165in (55.00mm)	DEP06055	CIH0081S	440			
DMAX06067	2.657in (67.50mm)	DEP06067	CIH0082S	350			
DMAX06080	3.150in (80.00mm)	DEP06080	CIH0083S	400			
DMAX06092	3.642in (92.50mm)	DEP06092	CIH0084S	565	RDP38021	500	DTC38001 or DTC38002* (High-Heat)
DMAX06105	4.134in (105.00mm)	DEP06105	CIH0085S	500			
DMAX06130	5.118in (130.00mm)	DEP06130	CIH0086S	500			
DMAX06155	6.102in (155.00mm)	DEP06155	CIH0087S	550			

* Locating rings must be ordered separately.

* NOTE: FOR HIGH-HEAT APPLICATIONS (>625F) PLEASE CONTACT DME APPLICATION ENGINEERING FOR DESIGN ASSISTANCE- appl_eng@dme.net

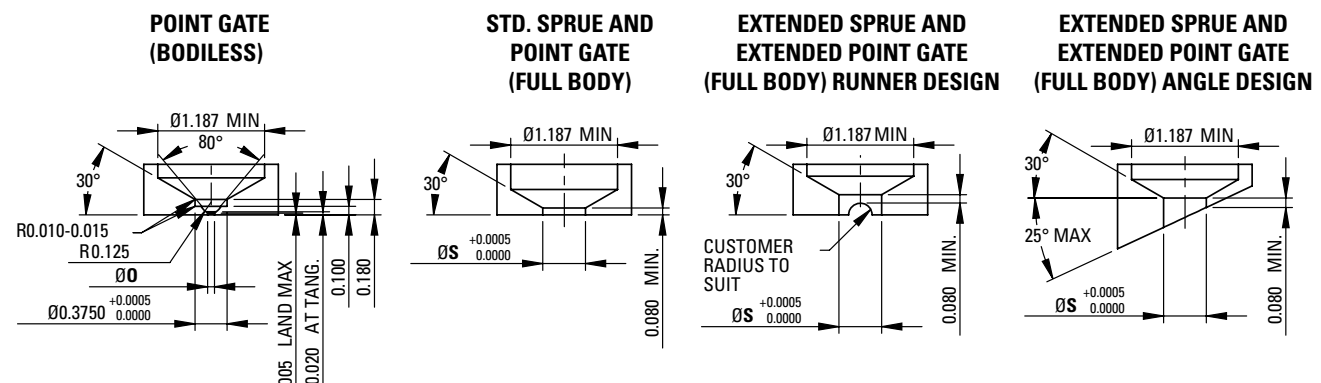

High Performance Hot Sprue Bushing 375 Series

NOTE: Dimensions shown in inches unless specified otherwise.

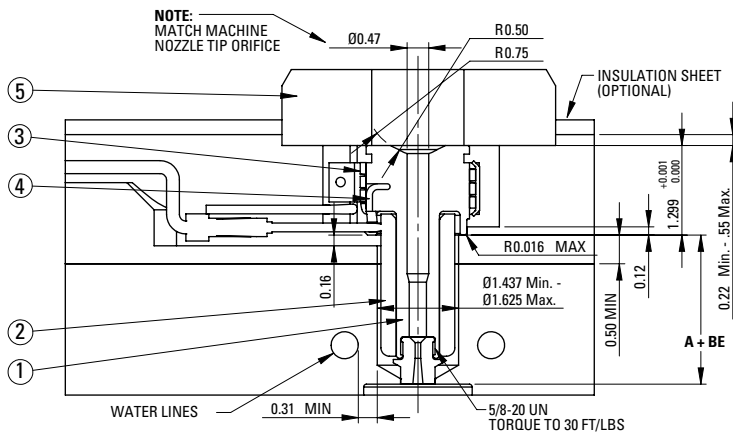
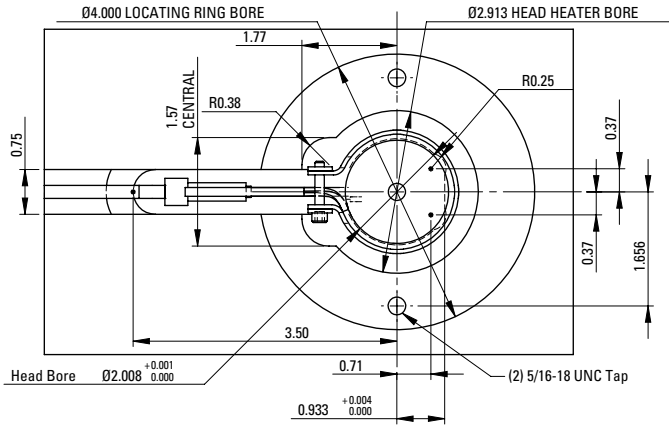

For selection of gate diameter it is important to take into consideration the material flow characteristics, share rate of resin, molding conditions, fill time requirements, gate vestige, wall thickness and configuration of parts to be molded. Situations requiring high injection velocities must be considered when selecting small gate diameters. High injection rates may require larger gates due to shear heat build up (e.g. high weight thin wall applications). See material manufacturer's literature for further information regarding material to be molded.

To compensate for nozzle's growth when heat is applied, the linear expansion of the nozzle (BE) at a given temperature must be added to the nominal "A" dimension. The formula below shows how to figure boring depth (dimension "A" + BE). The tip of the nozzle will now be flush with the cavity line at processing temperature.

Formula for determining this expansion factor is as follows:
 $BE = "A" \text{ dimension} \times 0.00000633 \times \text{nozzle set point} - 68^{\circ}\text{F}$
 (assuming the mold is at 68°F during operation). If mold temperature is different, substitute 68°F with actual mold temperature.

EXAMPLE: Given a 2.362 inch "A" dimension, with a set point of 500°F:
 $BE = 2.362 \times 0.00000633 \times (500 - 68) = 0.0064$
 Thus "A" + BE will be 2.368

NOTE: The above information is only given as an example; variations may occur based on mold configurations and cooling factor. In some instances, it may be necessary to obtain an empirical factor.

"O" DIA.		"S" DIA.
UNFILLED RESIN	FILLED RESIN	
0.028 Min.	0.062 Min.	0.5005
		0.7505
		1.0005

High Performance Sprue Bushing - 375 Series

BUSHING AND COMPONENT SPECIFICATIONS

ASSEMBLY	"A" DIMENSION	ASSEMBLY COMPONENTS					
		BUSHING BODY DETAIL #1	HIGH PERFORMANCE HEATER DETAIL #2	WATTAGE	HEAD HEATER DETAIL #3	WATTAGE	THERMOCOUPLE DETAIL #4
DMAX10060	2.362in (60.00mm)	DEP10060	CIH0088S	400	RDP50021	750	DTC38001 or DTC38002* (High-Heat)
DMAX10072	2.854in (72.50mm)	DEP10072	CIH0089S	450			
DMAX10085	3.346in (85.00mm)	DEP10085	CIH0090S	550			
DMAX10097	3.839in (97.50mm)	DEP10097	CIH0091S	700			
DMAX10110	4.331in (110.00mm)	DEP10110	CIH0092S	800			
DMAX10135	5.315in (135.00mm)	DEP10135	CIH0093S	900			
DMAX10160	6.299in (160.00mm)	DEP10160	CIH0094S	1000			
DMAX10185	7.283in (185.00mm)	DEP10185	CIH0095S	1100			

* Locating rings must be ordered separately.

* NOTE: FOR HIGH-HEAT APPLICATIONS (>625F) PLEASE CONTACT DME APPLICATION ENGINEERING FOR DESIGN ASSISTANCE- appl_eng@dme.net

POINT GATE (BODILESS)

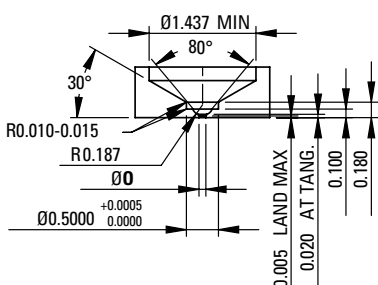

STD. SPRUE AND POINT GATE (FULL BODY)

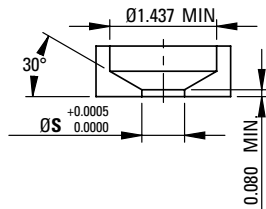

EXTENDED SPRUE AND EXTENDED POINT GATE (FULL BODY) RUNNER DESIGN

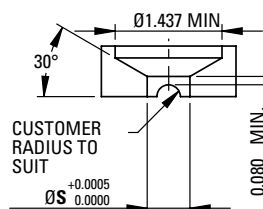

EXTENDED SPRUE AND EXTENDED POINT GATE (FULL BODY) ANGLE DESIGN

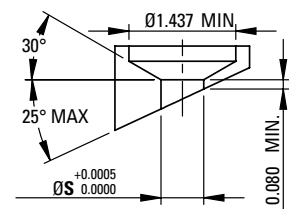

High Performance Hot Sprue Bushing 625 Series

NOTE: Dimensions shown in inches unless specified otherwise.

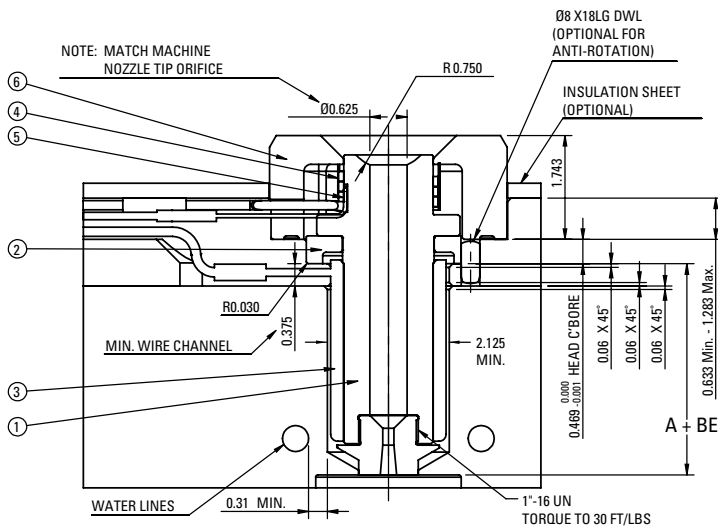
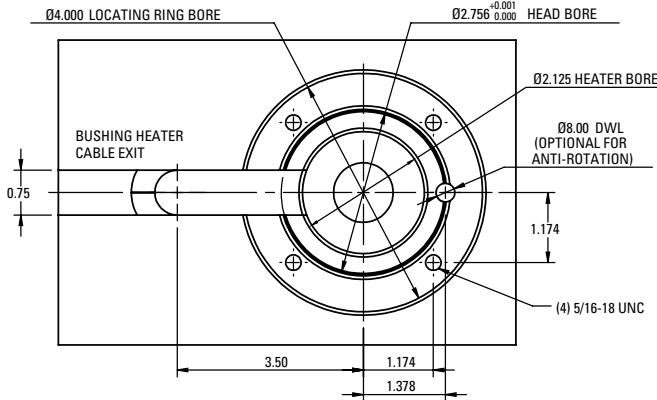

For selection of gate diameter it is important to take into consideration the material flow characteristics, shear rate of resin, molding conditions, fill time requirements, gate vestige, wall thickness and configuration of parts to be molded. Situations requiring high injection velocities must be considered when selecting small gate diameters. High injection rates may require larger gates due to shear heat build up (e.g. high weight thin wall applications). See material manufacturer's literature for further information regarding material to be molded.

To compensate for nozzle's growth when heat is applied, the linear expansion of the nozzle (BE) at a given temperature must be added to the nominal "A" dimension. The formula below shows how to figure boring depth (dimension "A" + BE). The tip of the nozzle will now be flush with the cavity line at processing temperature.

Formula for determining this expansion factor is as follows:
 $BE = \text{"A" dimension} \times 0.00000633 \times \text{nozzle set point} - 68^{\circ}F$
 (assuming the mold is at 68°F during operation). If mold temperature is different, substitute 68°F with actual mold temperature.

EXAMPLE: Given a 3.543in "A" dimension, with a set point of 500°F and mold temperature 68°F:
 $BE = 3.543 \times 0.00000633 \times (500 - 68) = .010$
 Thus "A" + BE will be 3.553

NOTE: The above information is only given as an example; variations may occur based on mold configurations and cooling factor. In some instances, it may be necessary to obtain an empirical factor.

"O" DIA.		"S" DIA.
UNFILLED RESIN	FILLED RESIN	
0.080 Min.	0.100 Min.	1.0005

High Performance Bushing - 625 Series

BUSHING AND COMPONENT SPECIFICATIONS

ASSEMBLY	"A" DIMENSION	ASSEMBLY COMPONENTS						
		BUSHING BODY DETAIL #1	BUSHING HEAD DETAIL #2	CAST-IN HEATER DETAIL #3	WATTAGE	HEAD HEATER DETAIL #4	WATTAGE	THERMOCOUPLE DETAIL #5
DMAX16090	3.543in (90.00mm)	DEP16090		CIH0104-S	847			
DMAX16115	4.528in (115.00mm)	DEP16115		CIH0096-S	1000			
DMAX16140	5.512in (140.00mm)	DEP16140		CIH0097-S	1030			
DMAX16165	6.496in (165.00mm)	DEP16165	DBP16001	CIH0098-S	1100	RDP38021	500	DTC62501
DMAX16190	7.480in (190.00mm)	DEP16190		CIH0099-S	1000			
DMAX16215	8.465in (215.00mm)	DEP16215		CIH0101-S	1200			
DMAX16240	9.449in (240.00mm)	DEP16240		CIH0102-S	1200			
DMAX16265	10.433in (265.00mm)	DEP16265		CIH0103-S	1200			

* Locating rings must be ordered separately.

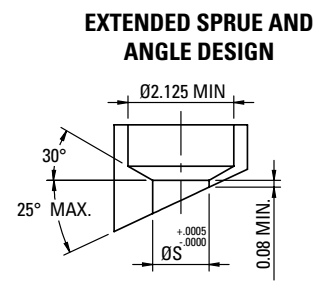
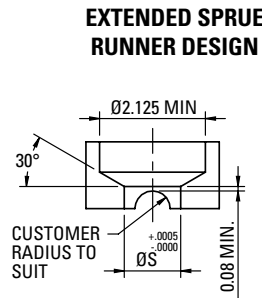
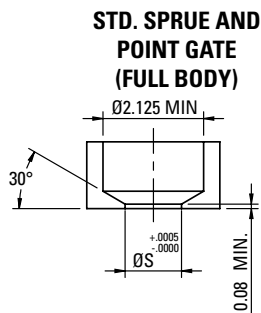
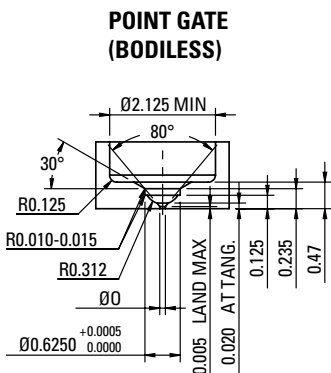

Gate Tip Detail

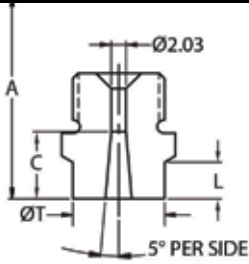

Sprue Gate/Extended Sprue Gate

SERIES	GATE TIP	ITEM NUMBER	B DIA.	T DIA.	L	C
250	SPRUE GATE	EHT0010	.080	.500	.250	.375
		EHT0011		.750		
		EHT0012		1.000		
	EXTENDED SPRUE GATE	EHT0013		.500	1.000	1.125
		EHT0014		.750		
		EHT0015		1.000		
375	SPRUE GATE	EHT0016	.125	.500	.250	.375
		EHT0017		.750		
		EHT0018		1.000		
	EXTENDED SPRUE GATE	EHT0019		.500	1.000	1.125
		EHT0020		.750		
		EHT0021		1.000		
625	SPRUE GATE	EHT0022	.187	.250	.500	.500
	EXTENDED SPRUE GATE	EHT0023		1.000		

(Add .750 to A dimension for extended sprue gate tips.)

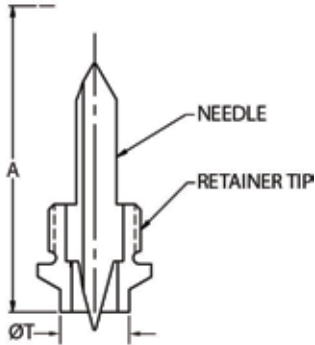

Point Gate (Bodiless)

SERIES	GATE TIP	ITEM NUMBER	T DIA.	INCLUDES	
				NEEDLE	RETAINER TIP
250	STANDARD	EHT0005	.375	EHN0015	EHT0024
		EHT1314			EHT0324
	WEAR RESISTANT	EHT1308		EHT0324	
		EHT1313		EHT1324	
375	STANDARD	EHT0039	.500	EHN0016	EHT0025
		EHT1312			EHT0325
	WEAR RESISTANT	EHT1303		EHT0325	
		EHT1309		EHT1325	
625	STANDARD	EHT1306	.625	EHN0019	EHT1354
		EHT1311			EHT0326
	WEAR RESISTANT	EHT1307		EHT0326	
		EHT1310		EHT1354	

Point Gate (Full Body)

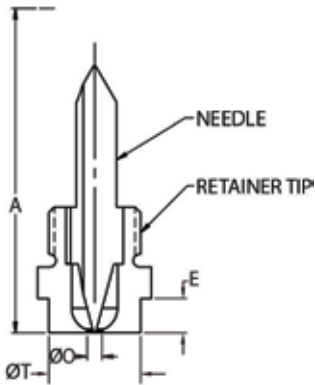

SERIES	TYPE	ITEM NUMBER	T DIA.	O DIA.	E	INCLUDES		
						NEEDLE	RETAINER TIP	
250	STANDARD	EHT2001	.375	.060	.187	EHN0015	EHT0026	
		EHT2002					EHT0027	
		EHT2003					EHT0028	
		EHT2004					EHT0029	
	WEAR RESISTANT	EHT2005	.500	.060		.080	EHN0401	EHT1326
		EHT2006						EHT1327
		EHT2007						EHT1328
		EHT2008						EHT1329
375	STANDARD	EHT2009	.500	.080	.230	EHN0016	EHT0030	
		EHT2010					EHT0031	
		EHT2011					EHT0032	
		EHT2012					EHT0033	
		EHT2013					EHT0034	
		EHT2014					EHT0035	
	WEAR RESISTANT	EHT2015	.750	.100		.080	EHN0400	EHT1330
		EHT2016						EHT1331
		EHT2017						EHT1332
		EHT2018						EHT1333
		EHT2019						EHT1334
		EHT2020						EHT1335
625	STANDARD	EHT2021	1.000	.125	.250	EHN0019	EHT0036	
	WEAR RESISTANT	EHT2022					EHN0402	EHT1336

Point Gate (Full Body Extended)

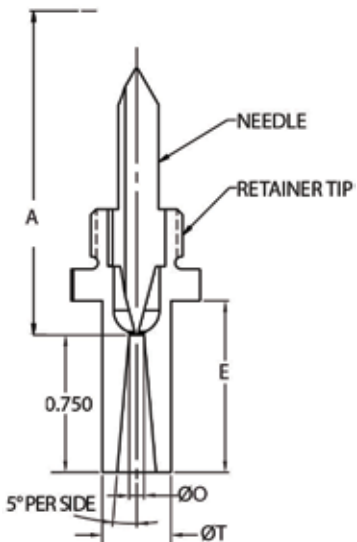

SERIES	TYPE	ITEM NUMBER	T DIA.	O DIA.	E	INCLUDES		
						NEEDLE	RETAINER TIP	
250	STANDARD	EHT2301	.375	.060	.938	EHN0015	EHT2326	
		EHT2302					EHT2327	
		EHT2303					EHT2328	
		EHT2304					EHT2329	
	WEAR RESISTANT	EHT2305	.500	.060		.080	EHN0401	EHT2326
		EHT2306						EHT2327
		EHT2307						EHT2328
		EHT2308						EHT2329
375	STANDARD	EHT2309	.500	.080	.980	EHN0016	EHT2330	
		EHT2310					EHT2331	
		EHT2311					EHT2332	
		EHT2312					EHT2333	
		EHT2313					EHT2334	
		EHT2314					EHT2335	
	WEAR RESISTANT	EHT2315	.750	.100		.080	EHN0400	EHT2330
		EHT2316						EHT2331
		EHT2317						EHT2332
		EHT2318						EHT2333
		EHT2319						EHT2334
		EHT2320						EHT2335
625	STANDARD	EHT2321	1.000	.125	1.000	EHN0019	EHT2336	
	WEAR RESISTANT	EHT2322					EHN0402	EHT2336

SERIES	THREAD TYPE
250	1/2-24 UN
375	5/8-20 UN
625	1"-16 UN

250, 375 & 625 Series Locating Rings

250, 375 & 625 Series Locating Rings

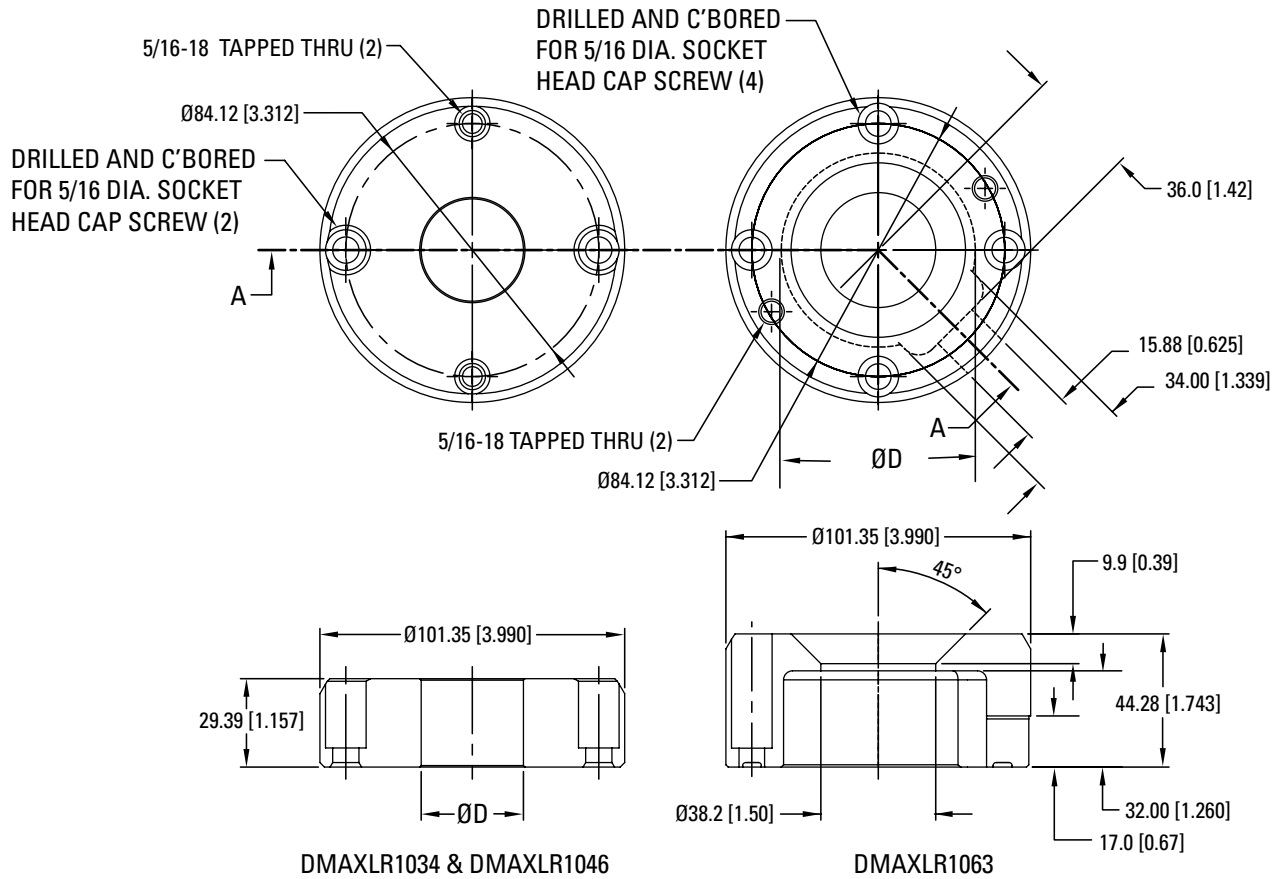

SECTION A-A

ITEM NUMBER	Ø D
DMAXLR1034	34.00 (1.34")
DMAXLR1046	46.00 (1.81")
DMAXLR1063	63.00 (2.48")

NOTE: Dimensions shown in millimeters, inches in parentheses

DME Gate-Mate® Hot Sprue Bushings

IDEAL FOR DIRECT
PART GATING,
SINGLE-CAVITY MOLDS



Gate-Mate® Applications and Benefits

DME Gate-Mate® Hot Sprue Bushings

The DME Gate-Mate® Hot Sprue Bushing is designed for direct part gating in single-cavity molds, eliminating the conventional cold sprue. The unique design of the bushing provides minimal gate vestige, without the objectionable witness lines so commonly found on direct gated parts.

The bushing transfers molten plastics from the machine nozzle to the mold cavity via a direct channel in the body. The plated copper alloy tip provides an improved temperature profile in the gate area.

The DME Gate-Mate® Hot Sprue Bushing utilizes an advanced design square coil heater and independent thermocouple, strategically located for precise temperature control. The bushing is available in three sizes to suit a variety of applications.

See the DME Control Systems Catalog for Smart Series® Single Zone Temperature Controllers.



Mini and Jumbo Style Gate-Mate Bushings Shown

Typical Applications

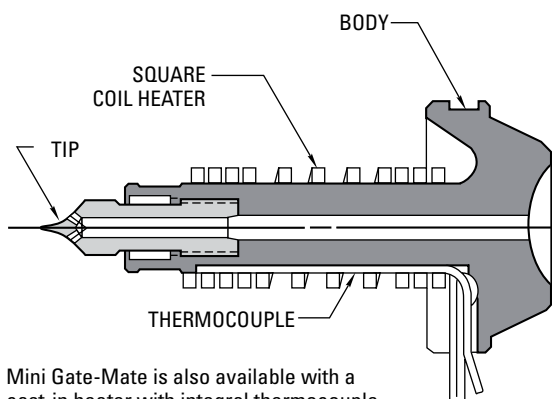
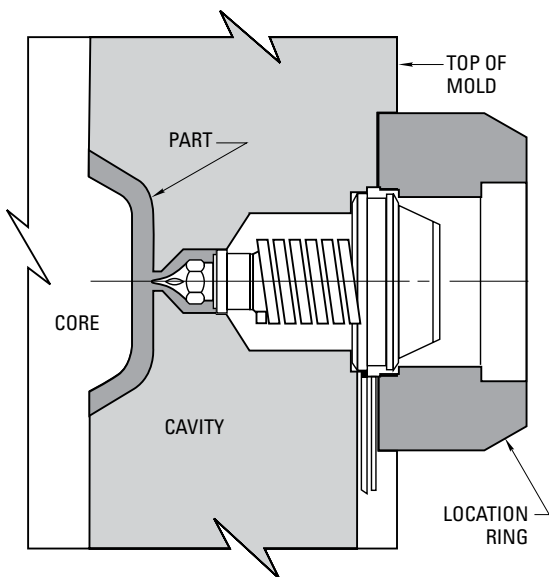

NOTE: Mini Gate-Mate is also available with a cast-in heater with integral thermocouple.

Benefits

- Eliminates sprues, reduces cycle time, improves part quality, increases production
- Provides optimum gate cosmetics
- Plated copper alloy tip improves temperature profile in gate area
- Self insulating material layer surrounds tip for better tip control and part cooling
- Square coil heater and independent thermocouple provide precise temperature control
- Optional cast in heater available for Mini Gate-Mate bushing

Advantages

- Direct part gating eliminating a cold sprue to trim and no witness lines on the molded part
- Minimal gate vestige resulting in better part appearance
- Faster start-ups providing positive temperature control of gate area
- Reduced cycle times because the bushing allows cooling channels to be placed closer to the gate area
- Cooler cavities with no direct contact between bushing tip and cavity
- Improved part quality with a shorter injection path and elimination of sprue, meaning no regrind
- Increased production with faster cycles and no sprue trimming
- Easy installation and operation, and available in three standard sizes suitable for most applications
- Positive temperature control with J-Type thermocouple and DME Smart-Series® (and G-Series) controllers

Mini Gate-Mate®



Radius Type



Flat Type

The Mini Gate-Mate Bushings are ideal for fast cycling single cavity molds. The compact design permits shorter overall stack-up of the "A" side mold plates. The Mini Gate-Mate Bushings are provided with either a square coil heater or a cast-in heater. Thermocouple placement provides better heater control, and the overall body design improves thermal insulation. Square coil heater, thermocouple and tip are all replaceable.

Sub-assemblies include square coil heater and thermocouple or cast-in heater with integral thermocouple. Tip to be ordered separately.

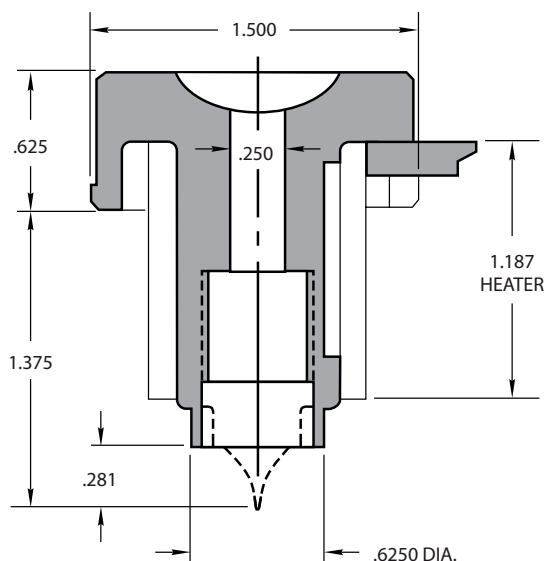
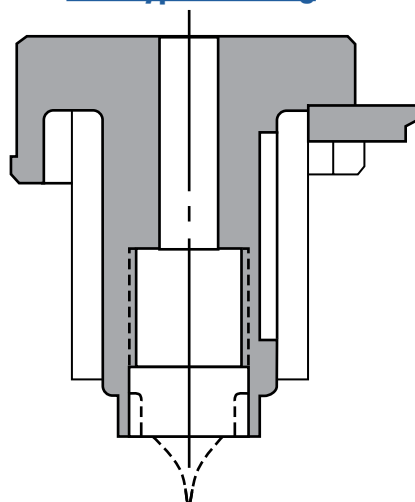
1/2" SPH. Radius Type Bushing**Flat Type Bushing**

Dimensions same as radius type bushing

1/2" SPH. RADIUS BUSHING SUB-ASSEMBLY

ITEM NUMBER	HEATER TYPE
GMB0116	SQUARE COIL
GMB0111	CAST-IN

NOTE:
Tip to be ordered separately

FLAT BUSHING SUB-ASSEMBLY

ITEM NUMBER	HEATER TYPE
GMB0117	SQUARE COIL
GMB0112	CAST-IN

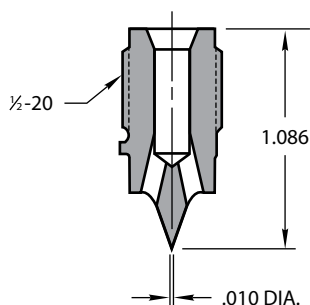
Mini Gate-Mate® Tips

ITEM NUMBER	TIP STYLE
GMT0100	STANDARD
GMT4101	WEAR RESISTANT

Contact for DME for tip recommendations and assistance with your application.

Mini Gate-Mate® Machining Dimensions

Machining Dimensions for Bushings

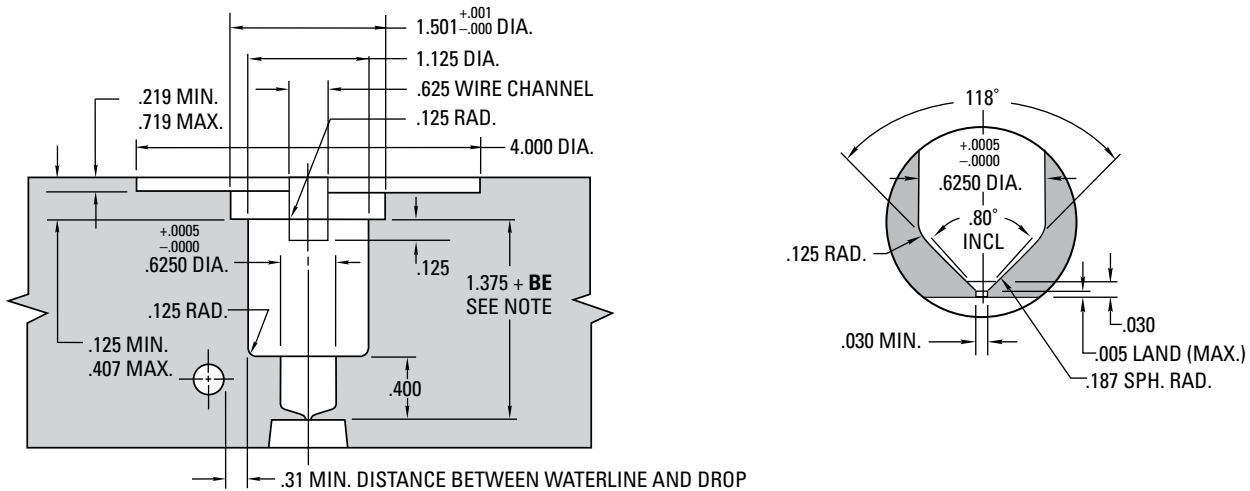

NOTE:

The expansion factor must be taken into consideration prior to machining for and installation of the bushing. This factor (BE) must then be added to the A dimension. The formula for determining this expansion factor is as follows:

BE = "A" dimension x 0.00000633 x nozzle set point - 68°F (assuming the mold is at 68°F during operation). If mold temperature is different, substitute 68°F with actual mold temperature.

EXAMPLE:

Given a setpoint of 500°F: BE = 1.375 x .00000633 x (500 - 68) = .004 thus 1.375 + .004 = 1.379.

Please note that the above information is given as an example. Variations may occur based on mold configuration and cooling factor. In some instances, it may be necessary to obtain an empirical factor.

Replacement Parts

SUB-ASSEMBLY REFERENCE	BODY TYPE	HEATER TYPE (240 VAC, 250 WATT)	THERMOCOUPLE (36" LEADS)	NOZZLE BODY ONLY
GMB0111	½ RADIUS	(CAST IN)	N/A	GMB0103
GMB0112	FLAT	CIH0100	(INTEGRAL TO HEATER)	GMB0104
GMB0116	½ RADIUS	(SQUARE COIL)	TCG0100	GMB0103
GMB0117	FLAT	SCH0004		GMB0104

Mini Gate-Mate Bushing Locating Ring

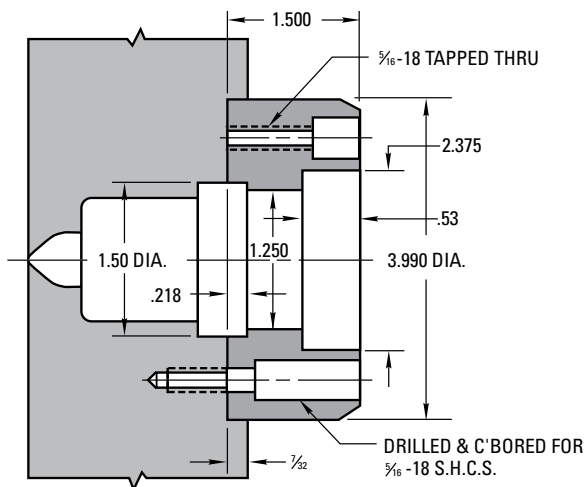

ITEM NUMBER
6548

NOTES:

- Two (2) 5/16-18 S.H.C.S. are included with Locating Ring
- Two (2) Drilled and C'bored holes for 5/16-18 S.H.C.S. are on a 1.656 circle radius in Locating Ring
- C'bore depth in Top Clamp Plate and C'bore depth in Locating Ring can be altered to suit application

Medium Gate-Mate®

The Medium Gate-Mate Bushing is designed for direct part gating in single cavity molds, eliminating the conventional cold sprue. The unique design of the bushing provides minimal gate vestige, without the objectionable witness lines so commonly found on direct gated parts.

The bushing transfers molten plastics from the machine nozzle to the mold cavity via a direct channel in the body. The bushing, in conjunction with the recommended tip and gate configuration, controls gate vestige height.

The Medium Gate-Mate Bushing utilizes an advanced design square coil heater and an independent thermocouple, strategically located for precise temperature control.



Bushing Assembly

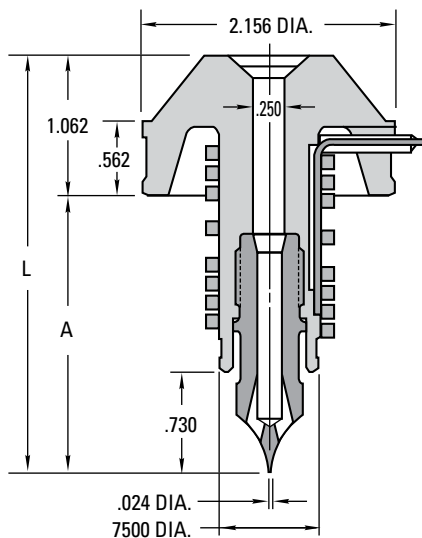

Bushing Sub-Assembly

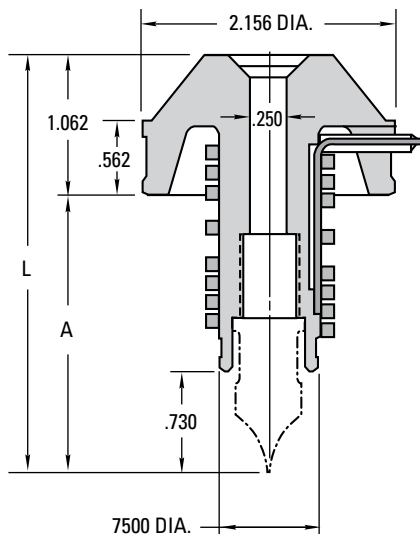

BUSHING ASSEMBLY (INCLUDES GMT2 TIP)

ITEM NUMBER	A	L	DUAL SPH. RAD.
GMB5232	2.375	3.437	1/2 & 3/4
GMB5332	3.375	4.437	

BUSHING SUB-ASSEMBLY (ORDER TIP SEPARATELY)

ITEM NUMBER	A	L	DUAL SPH. RAD.
GMB0020	2.375	3.437	1/2 & 3/4
GMB0030	3.375	4.437	

Medium Gate-Mate® Tips

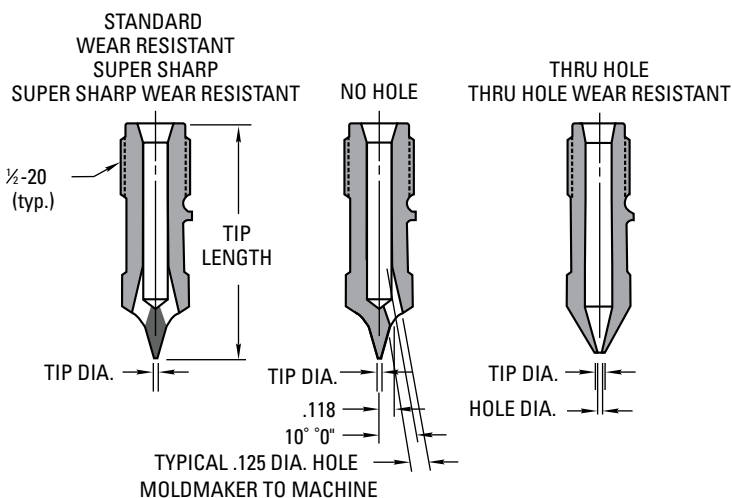

TIP STYLE	TIP ITEM NUMBER	O DIA.	TIP LENGTH	TIP DIA.	HOLE DIA.
STANDARD	GMT2	.044 MIN.	1.730	.024	N/A
WEAR RESISTANT	GMT0400	.055 MIN.			
SUPER SHARP	GMT0301	.030 MIN.			
SUPER SHARP WEAR RESISTANT	GMT0401	.055 MIN.	1.690	.090	.050
THRU HOLE	GMT0302*	.030 MIN. .050 MAX			
THRU HOLE WEAR RESISTANT	GMT0402*	.055 MIN.			
NO HOLE	GMT0303	.044 MIN.	1.730	.024	N/A

NOTES:

1. Thru-hole tip is designed .040 shorter in length to be a direct replacement for the standard tip; use a .030 to .060 diameter gate
2. A .030 minimum diameter gate is recommended when using the super sharp tip
3. Contact DME for tip recommendations and assistance with your application

*Contact DME for details to modify thru-hole tips for larger "O" diameters.

Medium Gate-Mate® Machining Dimensions

Machining Dimensions for Bushings

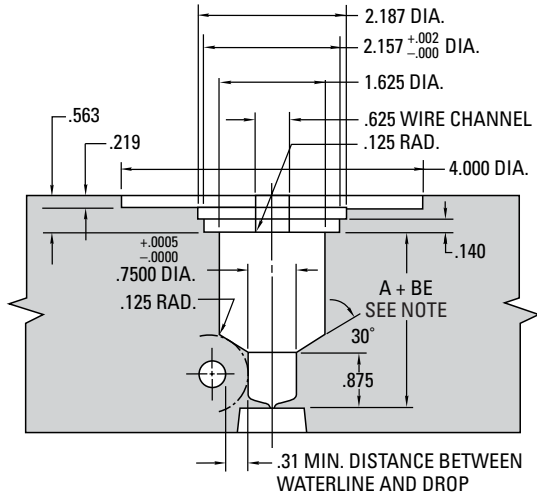

Improved tip insulation, elimination of material degradation in threaded area of tip, and faster color changes can be achieved through use of a Gate Shell Insulator.

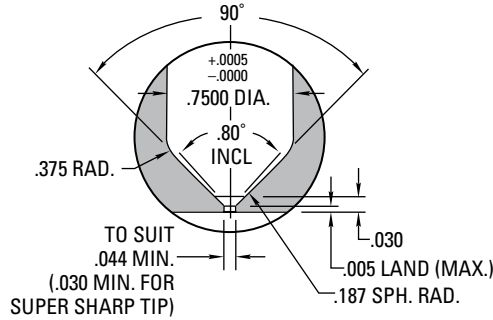

NOTE:

The expansion factor must be taken into consideration prior to machining for, and installing bushing. This factor (BE) must then be added to the nominal A dimension. Formula for determining this expansion is as follows: $BE = "A" \text{ dimension} \times 0.00000633 \times \text{nozzle set point} - 68^\circ\text{F}$ (assuming the mold is at 68°F during operation). If mold temperature is different, substitute 68°F with actual mold temperature.

EXAMPLE:

Given a 2.375 inch A dimension, with a Bushing Set Point temp. of 500°F :
 $BE = 2.375 \times .0000063 \times (500 - 68) = .006$ thus A + BE will be 2.381.

Please note that the above information is given as an example. Variations may occur based on mold configurations and cooling factor. In some instances, it may be necessary to obtain an empirical factor.

ITEM NUMBER REFERENCE		A
BUSHING ASSEMBLY	BUSHING SUB-ASSEMBLY	
GMB5232	GMB0020	2.375
GMB5332	GMB0030	3.375

Replacement Parts

ITEM NUMBER REFERENCE		SQUARE COIL HEATERS (240 VAC)			THERMOCOUPLE (TYPE J, 36" LEADS)		NOZZLE BODY ONLY
BUSHING ASSEMBLY	BUSHING SUB-ASSEMBLY	ITEM NUMBER	WATTS	LENGTH	ITEM NUMBER	LENGTH	
GMB5232	GMB0020	SCH3142	315	1.70	TC9600	1.35	GMC-523
GMB5332	GMB0030	SCH3242	315	2.70	TC9700	2.35	GMC-533

Medium Gate-Mate Locating Ring

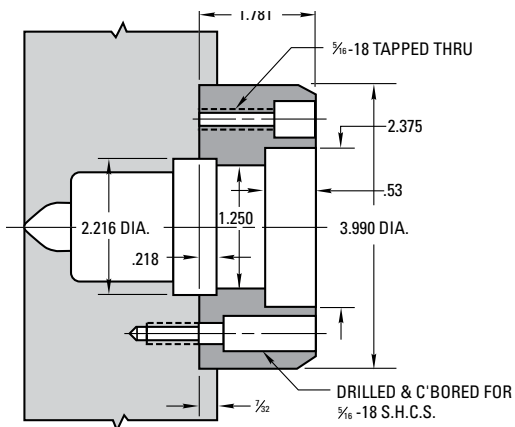

ITEM NUMBER
6545

NOTES:

- Two (2) $\frac{3}{16}$ -18 S.H.C.S. are included with Locating Ring
- Two (2) Drilled and C'bored holes for $\frac{3}{16}$ -18 S.H.C.S. are on a 1.656 circle radius in Locating Ring
- C'bore depth in Top Clamp Plate and C'bore depth in Locating Ring can be altered to suit application

Jumbo Gate-Mate®



The Jumbo Gate-Mate Bushing is designed for direct part gating in single cavity molds, eliminating the conventional cold sprue. The unique design of the bushing provides minimal gate vestige, without the objectionable witness lines so commonly found on direct gated parts.

The bushing transfers molten plastics from the machine nozzle to the mold cavity via a direct channel in the body. The bushing, in conjunction with the recommended tip and gate configuration, controls gate vestige height.

The Jumbo Gate-Mate Bushing utilizes an advanced design square coil heater and an independent thermocouple, strategically located for precise temperature control.

Bushing Assembly

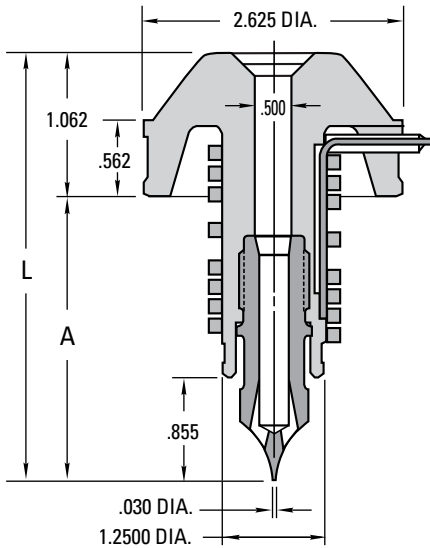

Bushing Sub-Assembly

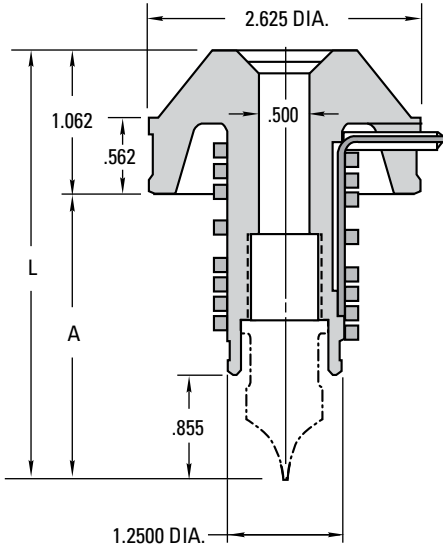

BUSHING ASSEMBLY (INCLUDES GMT0004 TIP)

ITEM NUMBER	A	L	SPH. RAD.
GMB0008	2.500	3.562	1/2 & 3/4
GMB0009	3.500	4.562	1/2 & 3/4

BUSHING SUB-ASSEMBLY (ORDER TIP SEPARATELY)

ITEM NUMBER	A	L	SPH. RAD.
GMB0113	2.500	3.562	1/2 & 3/4
GMB0114	3.500	4.562	1/2 & 3/4

Jumbo Gate-Mate® Tips

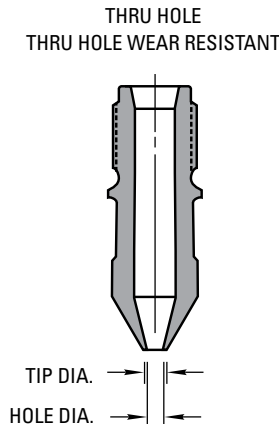
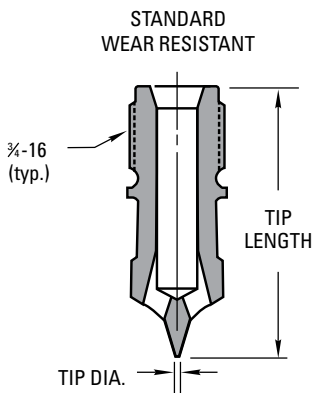

TIP STYLE	ITEM NUMBER	TIP LENGTH	TIP DIA.	HOLE DIA.
STANDARD	GMT0004	1.855	.030	N/A
WEAR RESISTANT	GMT0406			
THRU HOLE	GMT0007			
THRU HOLE WEAR RESISTANT	GMT0407	1.815	.140	.100

NOTES:

1. Thru-hole tip designed .040 shorter in length to be a direct replacement for the standard tip; use a .080 to .125 diameter gate
2. Contact DME for tip recommendations and assistance with your application

Jumbo Gate-Mate® Machining Dimensions

Machining Dimensions for Bushings

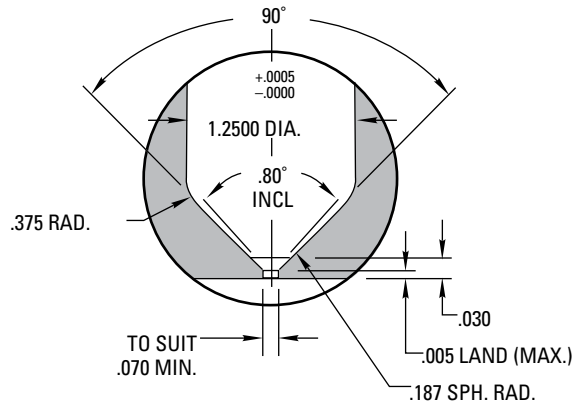
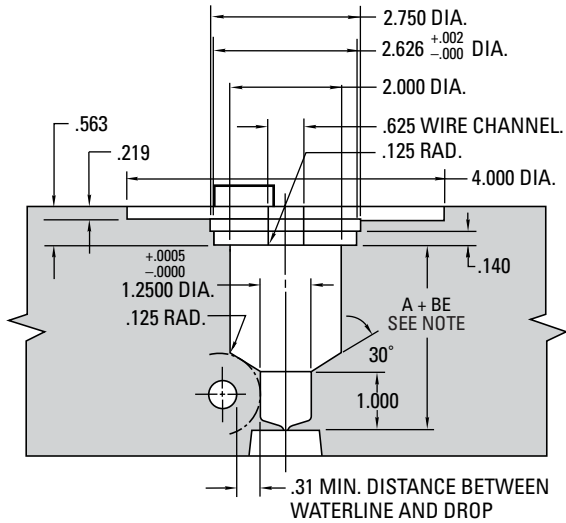

ITEM NUMBER REFERENCE		A
BUSHING ASSEMBLY	BUSHING SUB-ASSEMBLY	
GMB0008	GMB0113	2.500
GMB0009	GMB0114	3.500

NOTE:

The expansion factor must be taken into consideration prior to machining for, and installing bushing. This factor (BE) must then be added to the nominal A dimension. Formula for determining this expansion is as follows: BE = "A" dimension x 0.00000633 x nozzle set point - 68°F (assuming the mold is at 68°F during operation). If mold temperature is different, substitute 68°F with actual mold temperature.

EXAMPLE:

Given a 2.500 inch A dimension, with a Bushing Set Point temp. of 500°F: BE = 2.500 x 0.00000633 x (500 - 68) = .007 thus A + BE will be 2.507.

Please note that this information is given as an example. Variations may occur based on mold configurations and cooling factor. In some instances, it may be necessary to obtain an empirical factor.

Replacement Parts

Improved tip insulation, elimination of material degradation in threaded area of tip, and faster color changes can be achieved through use of a Gate Shell Insulator.

ITEM NUMBER REFERENCE		SQUARE COIL HEATERS (240 VAC)			THERMOCOUPLE (TYPE J, 36" LEADS)		NOZZLE BODY ONLY
BUSHING ASSEMBLY	BUSHING SUB-ASSEMBLY	ITEM NUMBER	WATTS	LENGTH	ITEM NUMBER	LENGTH	
GMB0008	GMB0113	SCH0002	600	1.70	TC0002	1.18	GMC0010
GMB0009	GMB0114	SCH0001	800	2.70	TC0001	2.18	GMC0005

Jumbo Gate-Mate Locating Ring

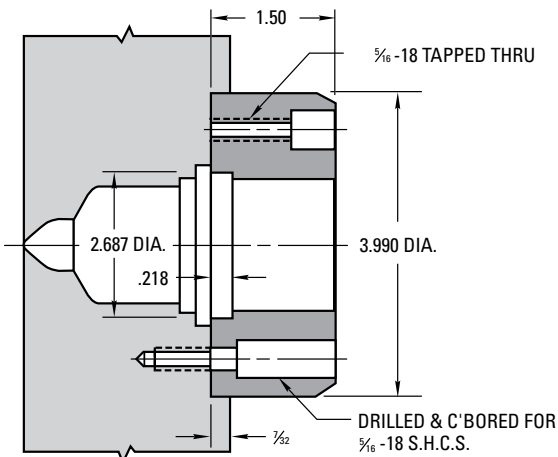

ITEM NUMBER
GMB0007

NOTES:

- Two (2) 3/16 -18 S.H.C.S. are included with Locating Ring
- Two (2) Drilled and C'bored holes for 3/16 -18 S.H.C.S. are on a 1.656 Circle radius in Locating Ring
- C'bore depth in Top Clamp Plate and C'bore depth in locating ring can be altered to suit application

DME Straight Shot® Hot Sprue Bushings



REDUCE CYCLE TIMES
AND SAVE MATERIAL COSTS

High-Performance Series Straight Shot®

High-Performance Straight Shot® bushings are available as S-type



NOTE:

The expansion factor must be taken into consideration prior to machining for and installation of the bushing. This factor (BE) must then be added to the A dimension. The formula for determining this expansion factor is as follows:

$$BE = "A" \text{ dimension} \times 0.00000633 \times \text{nozzle set point} - 68^{\circ}\text{F}$$

(assuming the mold is at 68°F during operation). If mold temperature is different, substitute 68°F with actual mold temperature.

EXAMPLE:

Given a setpoint of 500°F:
 $BE = 1.375 \times .0000063 \times (500 - 68) = .004$ thus $1.375 + .004 = 1.379$.
 Please note that the above information is given as an example. Variations may occur based on mold configuration and cooling factor. In some instances, it may be necessary to obtain an empirical factor.

"S" Type (Standard Tip Configuration)

- .062 or .125 DIA. Tips with .08 Land area
- Seven shoulder lengths from 7/8 to 3 7/8
- .500 And .750 Spherical radius for machine nozzle
- Replaces conventional cold sprue bushings to reduce cycle time and save material costs
- Efficiently processes commodity grade resins
- Provides low vestige gate cosmetics (.062 or .125 Gate diameters available)
- High-watt density heater with distributed wattage to help prevent tip freeze-offs

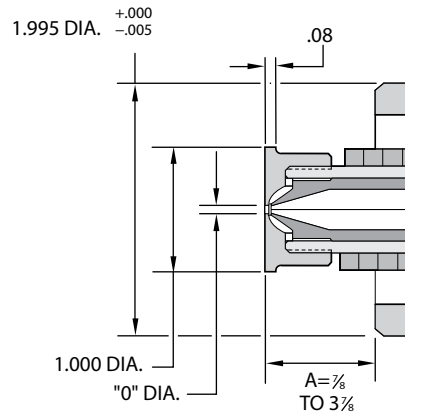
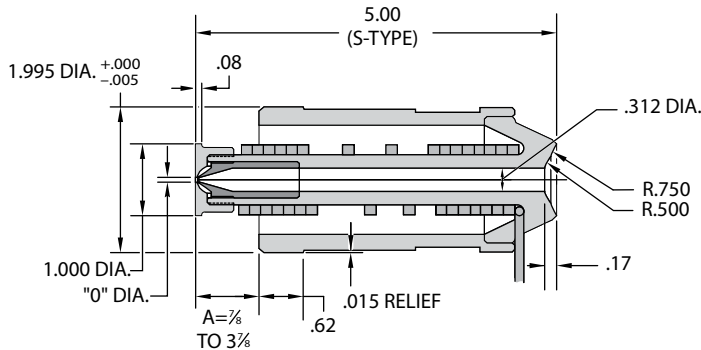

BUSHING ASSEMBLY			REPLACEMENT PARTS						
O DIA.	SHOULDER LENGTH A	BUSHING ASSEMBLY ITEM NUMBER	SHOULDER BUSHING ITEM NUMBER	TIP ITEM NUMBER	RETAINER ITEM NUMBER	BODY ITEM NUMBER	SPACER ITEM NUMBER	HEATER ITEM NUMBER	THERMOCOUPLE ITEM NUMBER
.062	7/8	HPS0607S2	HPS1007	HPT0001	HPT0601	HPS0001	HPT1001	HPS2001	HPS3001
	1 3/8	HPS0613S2	HPS1013						
	1 7/8	HPS0617S2	HPS1017						
	2 3/8	HPS0623S2	HPS1023						
	2 7/8	HPS0627S2	HPS1027						
	3 3/8	HPS0633S2	HPS1033						
	3 7/8	HPS0637S2	HPS1037						
.125	7/8	HPS1207S2	HPS1007	HPT0002	HPT1201	HPS0001	HPT1001	HPS2001	HPS3001
	1 3/8	HPS1213S2	HPS1013						
	1 7/8	HPS1217S2	HPS1017						
	2 3/8	HPS1223S2	HPS1023						
	2 7/8	HPS1227S2	HPS1027						
	3 3/8	HPS1233S2	HPS1033						
	3 7/8	HPS1237S2	HPS1037						

NOTE: High-Performance Series Straight Shot® Hot Sprue Bushings heater has voltage of 240 VAC, 700 watts. Thermocouple is "J" type.

High-Performance Series Straight Shot®

High-Performance Straight Shot® Bushings are available as E-type



"E" Type (Extended Tip Configuration)

- Replaces conventional cold sprue bushings to reduce cycle time and save material costs
- Efficiently processes commodity grade resins
- High-watt density heater with distributed wattage to help prevent tip freeze-offs
- .062 or .125 DIA. Tips with 0.49 Land area for machining of molded part details
- Seven shoulder lengths from 7/8 to 3 7/8
- 500 and .750 Spherical radius for machine nozzle

Always machine runner or part contour to the .277 maximum depth at centerline of gate. However, do not weaken the bushing face by exceeding this maximum dimension (Figures 1 and 2). Always machine part contour to the .277 maximum depth at edge of retainer, with 15° maximum angle. Machine a 3° minimum taper to the gate diameter. This will result in a small sprue on the part being molded (Figure 3). Machine a 3° minimum taper to the gate for a reverse taper sprue on the part being molded (Figure 4). Retainer material is H-13 steel 46-52 HRC.

NOTE:

The expansion factor must be taken into consideration prior to machining for and installation of the bushing. This factor (BE) must then be added to the A dimension. The formula for determining this expansion factor is as follows:
 $BE = "A" \text{ dimension} \times 0.00000633 \times \text{nozzle set point} - 68^{\circ}\text{F}$ (assuming the mold is at 68°F during operation). If mold temperature is different, substitute 68°F with actual mold temperature.

EXAMPLE:

Given a setpoint of 500°F:
 $BE = 1.375 \times .00000633 \times (500 - 68) = .004$ thus $1.375 + .004 = 1.379$.
 Please note that the above information is given as an example. Variations may occur based on mold configuration and cooling factor. In some instances, it may be necessary to obtain an empirical factor.

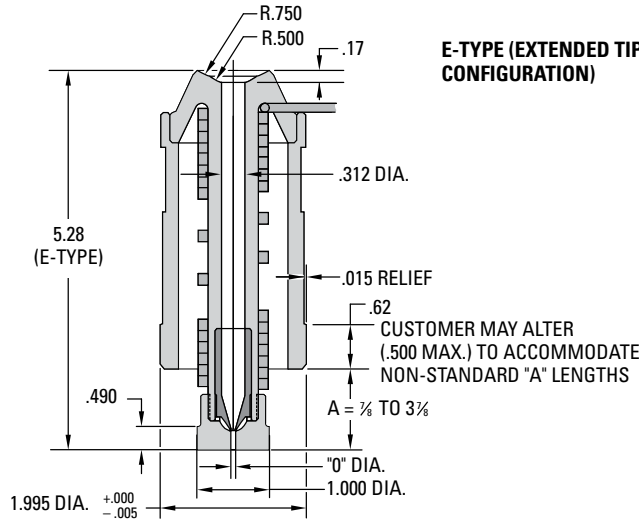
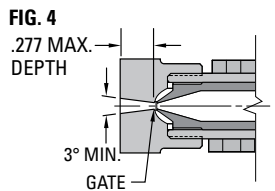
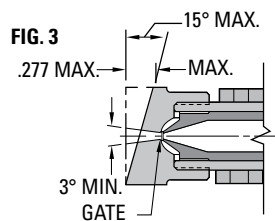
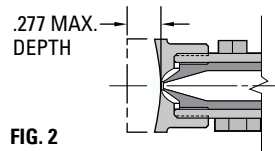
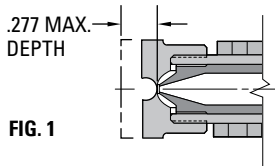

Straight Shot® Hot Sprue Bushings High-Performance Series Straight Shot®

Ø DIA.	SHOULDER LENGTH A	BUSHING ASSEMBLY ITEM NUMBER	SHOULDER BUSHING ITEM NUMBER	TIP ITEM NUMBER	RETAINER ITEM NUMBER	BODY ITEM NUMBER	SPACER ITEM NUMBER	HEATER ITEM NUMBER	THERMOCOUPLE ITEM NUMBER
.062	7/8	HPS0607E2	HPS2007	HPT0001	HPT0602	HPS0001	HPT1001	HPS2001	HPS3001
	1 3/8	HPS0613E2	HPS2013						
	1 7/8	HPS0617E2	HPS2017						
	2 3/8	HPS0623E2	HPS2023						
	2 7/8	HPS0627E2	HPS2027						
	3 3/8	HPS0633E2	HPS2033						
	3 7/8	HPS0637E2	HPS2037						
.125	7/8	HPS1207E2	HPS2007	HPT0002	HPT1202	HPS0001	HPT1001	HPS2001	HPS3001
	1 3/8	HPS1213E2	HPS2013						
	1 7/8	HPS1217E2	HPS2017						
	2 3/8	HPS1223E2	HPS2023						
	2 7/8	HPS1227E2	HPS2027						
	3 3/8	HPS1233E2	HPS2033						
	3 7/8	HPS1237E2	HPS2037						

NOTE: High-Performance Series Straight Shot® Hot Sprue Bushings heater has voltage of 240 VAC, 700 watts. Thermocouple is "J" type.

S-Series Straight Shot®

Larger Shots – Extended Heater Life

DME developed Straight Shot® Hot Sprue Bushings to eliminate sprues, permit larger shots and faster fills, and greatly extend heater life.

The bushings feature an unrestricted “straight-shot” channel to feed the part or runner. Material in the channel is heated by a special helical tubular heater which surrounds the melt stream. This heater distributes heat uniformly throughout the bushing and is virtually impervious to moisture, gases and plastics contamination.



U.S. Patent No. 4,273,525

The helical tubular heater (120 or 240 volt) is thermocouple equipped so temperature can be closely controlled using a DME single-zone Closed Loop Temperature Controller.

The standard S-Series Straight Shot is designed for direct part gating or for feeding half-round or trapezoidal runners. It is supplied with a .16 diameter gate and no gate land. Available in seven standard shoulder lengths with either a 1/2" or 3/4" spherical radius and 120 or 240 volt heater. The S-Series Straight Shot can be retrofitted to almost any mold that uses a conventional sprue bushing.

NOTE: 5° heater lead is standard. For 90° lead, add “90” to end of item number (e.g., SSBT4507S190).

R	WITH 120 VOLT HEATER	SHOULDER LENGTH A	WITH 240 VOLT HEATER
	ITEM NUMBER		ITEM NUMBER
1/2	SSBT4507S1	7/8	SSBT4507S2
	SSBT4513S1	1 1/8	SSBT4513S2
	SSBT4517S1	1 7/8	SSBT4517S2
	SSBT4523S1	2 3/8	SSBT4523S2
	SSBT4527S1	2 7/8	SSBT4527S2
	SSBT4533S1	3 3/8	SSBT4533S2
	SSBT4537S1	3 7/8	SSBT4537S2
3/4	SSBT6507S1	7/8	SSBT6507S2
	SSBT6513S1	1 1/8	SSBT6513S2
	SSBT6517S1	1 7/8	SSBT6517S2
	SSBT6523S1	2 3/8	SSBT6523S2
	SSBT6527S1	2 7/8	SSBT6527S2
	SSBT6533S1	3 3/8	SSBT6533S2
	SSBT6537S1	3 7/8	SSBT6537S2

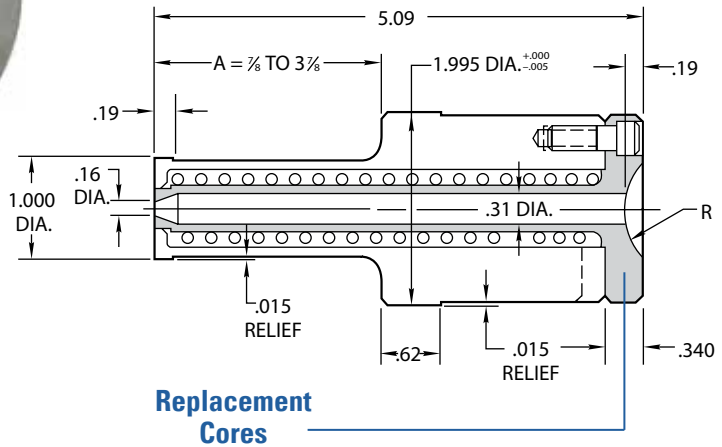

Replacement Cores

ITEM NUMBER	SPH. RAD.
SSBT45	.500
SSBT65	.750

NOTE: The expansion factor must be taken into consideration prior to machining for and installation of the bushing. This factor (BE) must then be added to the A dimension. The formula for determining this expansion factor is as follows:

BE = “A” dimension x 0.00000633 x nozzle set point - 68°F (assuming the mold is at 68°F during operation). If mold temperature is different, substitute 68°F with actual mold temperature.

EXAMPLE:

Given a setpoint of 500°F:

BE = 1.375 x .0000063 x (500 - 68) = .004 thus 1.375 + .004 = 1.379.

Please note that the above information is given as an example. Variations may occur based on mold configuration and cooling factor. In some instances, it may be necessary to obtain an empirical factor.

Typical Applications

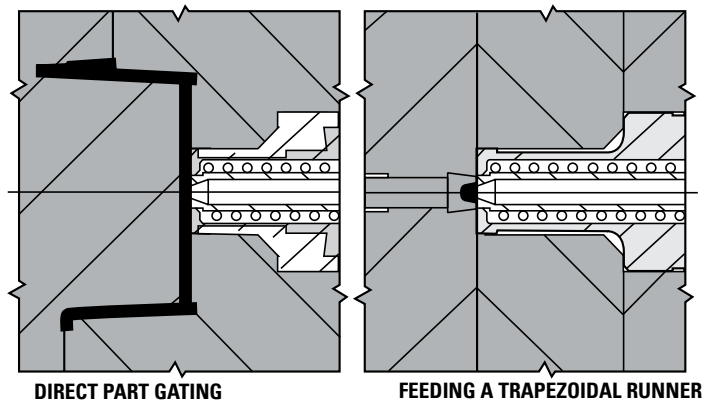

E-Series Straight Shot®

DME standard E-Series Straight Shot Hot Sprue Bushings (Long and Short Styles) provide a .25 inch extra stock allowance on the front face to permit machining of runner profiles or part contours into that face. They are supplied with a .06 diameter gate and a .25 inch gate land. The gate diameter can be enlarged to suit the particular molding application.



Long Style

See DME Control Systems Catalog for temperature controllers.

E-Series (Long Style)

NOTE:

Must always be altered as shown in Figures 1 thru 6 (see next page).

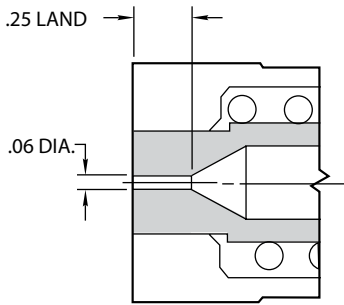

ENLARGED VIEW AS SUPPLIED

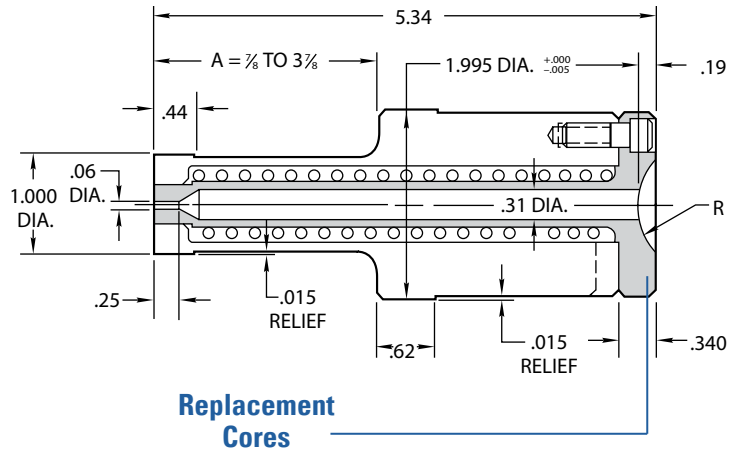

Replacement Cores

NOTE:

The expansion factor must be taken into consideration prior to machining for and installation of the bushing. This factor (BE) must then be added to the A dimension. The formula for determining this expansion factor is as follows:

BE = "A" dimension x 0.00000633 x nozzle set point - 68°F (assuming the mold is at 68°F during operation). If mold temperature is different, substitute 68°F with actual mold temperature.

EXAMPLE:

Given a setpoint of 500°F:

$$BE = 1.375 \times 0.0000633 \times (500 - 68) = .004 \text{ thus } 1.375 + .004 = 1.379.$$

Please note that the above information is given as an example. Variations may occur based on mold configuration and cooling factor. In some instances, it may be necessary to obtain an empirical factor.

The DME standard E-Series Straight Shot (Long Style) is available in seven standard shoulder lengths with either a 1/2" or 3/4" spherical radius and 120 or 240 volt heater. The E-Series Straight Shot (Long Style) can be retrofitted to suit the particular molding application.

NOTE: 5° heater lead is standard. For 90° lead, add "90" to end of item number (e.g., SSBT4507E190).

IEM NUMBER	SPH.RAD.
SSBT45E	.500
SSBT65E	.750

E-Series Straight Shot (Long Style) Hot Sprue Bushings

R	WITH 120 VOLT HEATER	SHOULDER LENGTH A	WITH 240 VOLT HEATER
	ITEM NUMBER		ITEM NUMBER
1/2	SSBT4507E1	7/8	SSBT4507E2
	SSBT4513E1	1 1/8	SSBT4513E2
	SSBT4517E1	1 1/4	SSBT4517E2
	SSBT4523E1	2 3/8	SSBT4523E2
	SSBT4527E1	2 7/8	SSBT4527E2
	SSBT4533E1	3 3/8	SSBT4533E2
	SSBT4537E1	3 7/8	SSBT4537E2
3/4	SSBT6507E1	7/8	SSBT6507E2
	SSBT6513E1	1 1/8	SSBT6513E2
	SSBT6517E1	1 1/4	SSBT6517E2
	SSBT6523E1	2 3/8	SSBT6523E2
	SSBT6527E1	2 7/8	SSBT6527E2
	SSBT6533E1	3 3/8	SSBT6533E2
	SSBT6537E1	3 7/8	SSBT6537E2

E-Series Straight Shot®

The DME standard E-Series Straight Shot (Short Style) is intended to suit the requirements of smaller injection molding machines and is supplied with a 7/8" A dimension. The A dimension can be altered to suit the particular molding application.



Short Style
See the DME Control Systems Catalog for temperature controllers.

E-Series Straight Shot Hot Sprue Bushings (Short Style)

WITH 240 VOLT HEATER	R	A DIMENSION
ITEM NUMBER		
SSBT4407E2	1/2	7/8
SSBT0407E2	NONE	

NOTE: 5° heater lead is standard. For 90° lead, add "90" to end of item number (e.g., SSBT4407E290).

E-Series (Short Style)

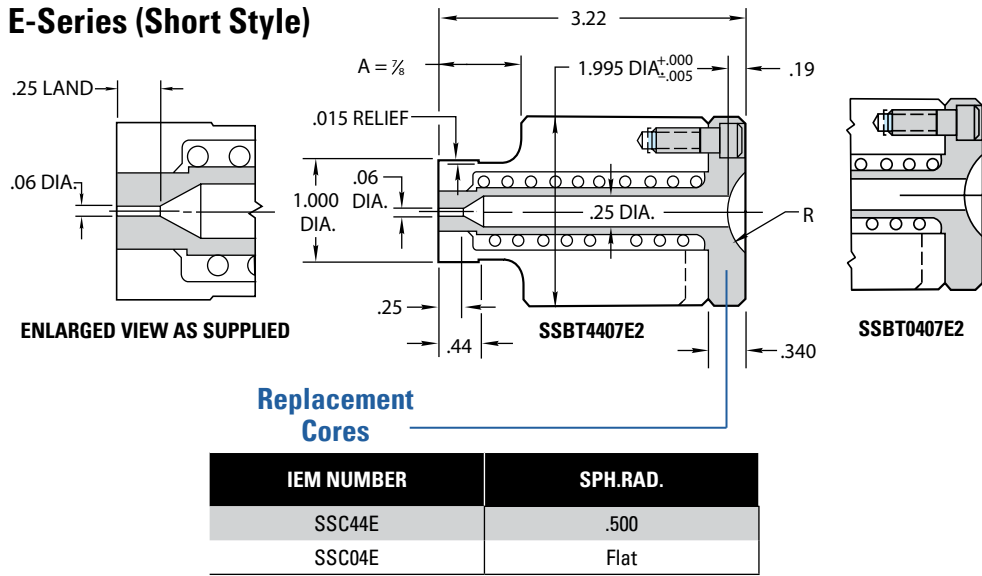

NOTE: The expansion factor must be taken into consideration prior to machining for and installation of the bushing. This factor (BE) must then be added to the A dimension. The formula for determining this expansion factor is as follows:
 $BE = "A" \text{ dimension} \times 0.0000633 \times \text{nozzle set point} - 68^{\circ}\text{F}$ (assuming the mold is at 68°F during operation). If mold temperature is different, substitute 68°F with actual mold temperature.

EXAMPLE:
 Given a setpoint of 500°F:
 $BE = 1.375 \times .0000633 \times (500 - 68) = .004$ thus $1.375 + .004 = 1.379$.
 Please note that the above information is given as an example. Variations may occur based on mold configuration and cooling factor. In some instances, it may be necessary to obtain an empirical factor.

NOTE: Must always be altered as shown in Figures 1 thru 6 (see below).

Design Guidelines for Altering E-Series Straight Shot® Hot Sprue Bushings (Long and Short Styles)

Always remove the .25 extra stock allowance and alter the A dimension to suit whenever gating into a flat part surface. Minimum stock removal of .25 provides an approximate .06 gate diameter (Figure 1).

Maximum stock removal of .268 provides an approximate .08 gate diameter (Figure 2). Maximum stock removal of .268 is recommended for gate diameters larger than .08 (Figures 3 and 4).

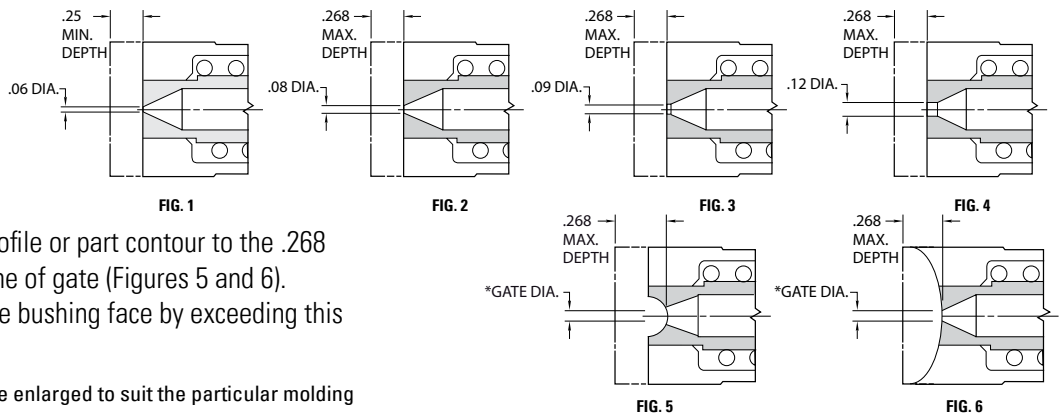

Always machine runner profile or part contour to the .268 maximum depth at centerline of gate (Figures 5 and 6). However, do not weaken the bushing face by exceeding this maximum dimension.

* Resultant gate diameter may be enlarged to suit the particular molding application.

ER-Series Straight Shot®

The DME standard ER-Series Straight Shot® Hot Sprue Bushings (Long and Short Styles), like the standard E-Series, are supplied with a .25 inch extra stock allowance on the front face to permit machining of runner profiles or part contours into that face. These bushings feature a "reverse taper" design that originates from under the heat source, providing easier start-ups.

The ER-Series design can also be used when a reverse taper will benefit a particular application. These bushings are supplied with a .12 diameter orifice and a .50 long reverse taper. The orifice may be enlarged and the taper increased to suit.



(Long Style)

ER-Series (Long Style)

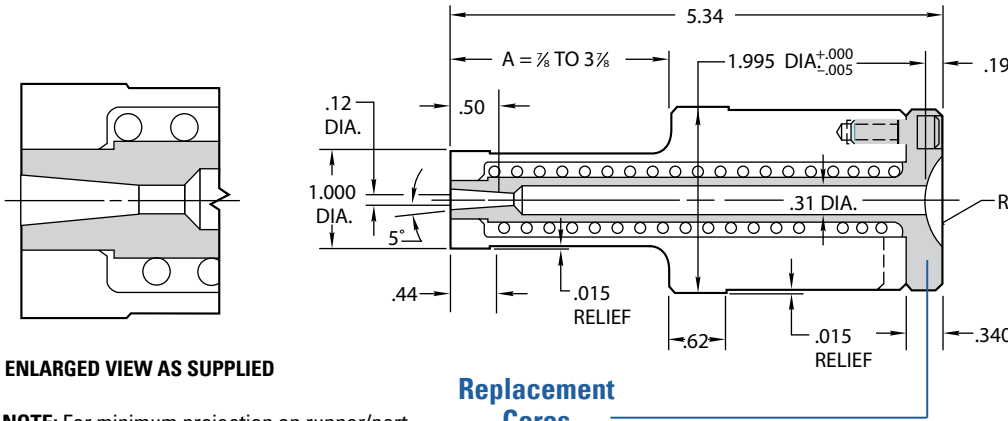

ENLARGED VIEW AS SUPPLIED

NOTE: For minimum projection on runner/part, alter the bushing face (See figures 1 thru 3 on next page).

Replacement Cores

IEM NUMBER	SPH.RAD.
SSC45ER	.500
SSC65ER	.750

NOTE:

The expansion factor must be taken into consideration prior to machining for and installation of the bushing. This factor (BE) must then be added to the A dimension. The formula for determining this expansion factor is as follows:

$$BE = "A" \text{ dimension} \times 0.00000633 \times \text{nozzle set point} - 68^{\circ}\text{F (assuming the mold is at } 68^{\circ}\text{F during operation). If mold temperature is different, substitute } 68^{\circ}\text{F with actual mold temperature.}$$

EXAMPLE:

Given a setpoint of 500°F:
 $BE = 1.375 \times 0.000063 \times (500 - 68) = .004$ thus $1.375 + .004 = 1.379$.

Please note that the above information is given as an example. Variations may occur based on mold configuration and cooling factor. In some instances, it may be necessary to obtain an empirical factor.

ER-Series Straight Shot (Long Style) Hot Sprue Bushings

R	WITH 120 VOLT HEATER	SHOULDER LENGTH A	WITH 240 VOLT HEATER
	ITEM NUMBER		ITEM NUMBER
1/2	SSBT4507ER1	7/8	SSBT4507ER2
	SSBT4513ER1	1 1/8	SSBT4513ER2
	SSBT4517ER1	1 1/4	SSBT4517ER2
	SSBT4523ER1	2 1/8	SSBT4523ER2
	SSBT4527ER1	2 1/4	SSBT4527ER2
	SSBT4533ER1	3 1/8	SSBT4533ER2
	SSBT4537ER1	3 1/4	SSBT4537ER2
3/4	SSBT6507ER1	7/8	SSBT6507ER2
	SSBT6513ER1	1 1/8	SSBT6513ER2
	SSBT6517ER1	1 1/4	SSBT6517ER2
	SSBT6523ER1	2 1/8	SSBT6523ER2
	SSBT6527ER1	2 1/4	SSBT6527ER2
	SSBT6533ER1	3 1/8	SSBT6533ER2
	SSBT6537ER1	3 1/4	SSBT6537ER2

The DME standard ER-Series Straight Shot® (Long Style) is available in seven standard shoulder lengths with either a 1/2" or 3/4" spherical radius and 120 or 240 volt heater. The ER-Series Straight Shot (Long Style) can be retrofitted to suit the particular molding application.

NOTE: 5° heater lead is standard. For 90° lead, add "90" to end of item number (e.g., SSBT4507ER190).

ER-Series Straight Shot®

The DME standard ER-Series Straight Shot® (Short Style) is intended to suit the requirements of smaller injection molding machines and is supplied with a 7/8" A dimension. The A dimension can be altered to suit the particular molding application.

NOTE: 5° heater lead is standard. For 90° lead, add "90" to end of item number (e.g., SSBT4407ER290).

NOTE:

The expansion factor must be taken into consideration prior to machining for and installation of the bushing. This factor (BE) must then be added to the A dimension. The formula for determining this expansion factor is, as follows: $BE = "A" \text{ dimension} \times 0.00000633 \times \text{nozzle set point} - 68^{\circ}\text{F}$ (assuming the mold is at 68°F during operation). If mold temperature is different, substitute 68°F with actual mold temperature.

EXAMPLE:

Given a setpoint of 500°F: $BE = 1.375 \times .0000063 \times (500 - 68) = .004$ thus $1.375 + .004 = 1.379$. Please note that the above information is given as an example. Variations may occur based on mold configuration and cooling factor. In some instances, it may be necessary to obtain an empirical factor.

Short Style



ER-Series Straight Shot Hot Sprue Bushings (Short Style)

WITH 240 VOLT HEATER	R	A DIMENSION
ITEM NUMBER		
SSBT4407ER2	1/2	7/8
SSBT0407ER2	NONE	

ER-Series (Short Style)

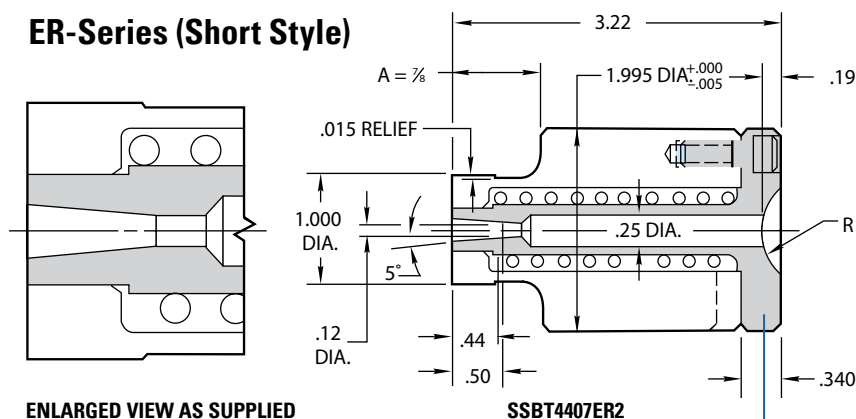

ENLARGED VIEW AS SUPPLIED

SSBT4407ER2

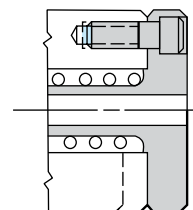

SSBT0407ER2

NOTE: For minimum projection on runner/part, alter the bushing face (See figures 1 through 3 below).

Replacement Cores

ITEM NUMBER	SPH. RAD.
SSC44ER	.500
SSC04ER	Flat

Design Guidelines for Altering ER-Series Straight Shot® Hot Sprue Bushings (Long and Short Styles)

FIG. 1

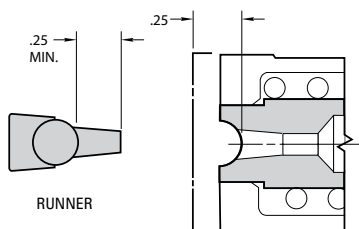

FIG. 2

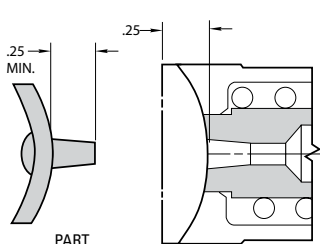
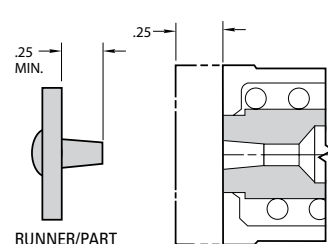

FIG. 3



For minimum projection on runner/part, machine the runner profile or part contour .25 inch deep into the bushing face at the centerline of the orifice (See Figures 1 and 2). When gating into a flat surface, remove the .25 inch extra stock allowance on the bushing face (See Figure 3). However, do not weaken the bushing face by exceeding the .25 inch dimension. The A dimension can be altered by removing stock from the front face of the 2.00 diameter bushing shoulder.

T-Series Straight Shot®

The DME standard "T" Series Straight Shot® improves the performance of three-plate molds by virtually eliminating the sprue from the runner system. It is available with either 1/2" or 3/4" spherical radius, 120 or 240 volt heater and a 7/8" or 1 1/8" long stripper plate bushing to suit the application.



NOTE: 5° heater lead is standard. For 90° lead, add "90" to end of item number (e.g., SSBT4517T10790).

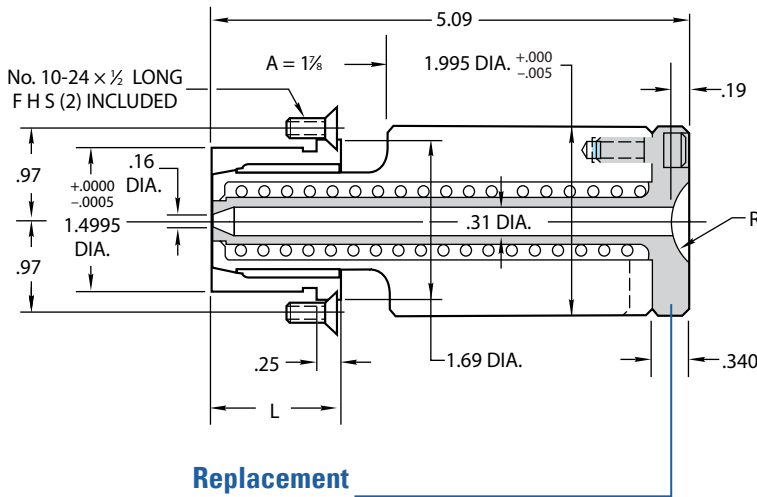

Replacement Cores

IEM NUMBER	SPH.RAD.
SSBT45	.500
SSBT65	.750

NOTE:

The expansion factor must be taken into consideration prior to machining for and installation of the bushing. This factor (BE) must then be added to the A dimension. The formula for determining this expansion factor is as follows:

BE = "A" dimension x 0.00000633 x nozzle set point - 68°F (assuming the mold is at 68°F during operation). If mold temperature is different, substitute 68°F with actual mold temperature.

EXAMPLE:

Given a setpoint of 500°F:

$$BE = 1.375 \times .0000063 \times (500 - 68) = .004 \text{ thus } 1.375 + .004 = 1.379.$$

Please note that the above information is given as an example. Variations may occur based on mold configuration and cooling factor. In some instances, it may be necessary to obtain an empirical factor.

T-Series Straight Shot Hot Sprue Bushings

R	WITH 120 VOLT HEATER	L	WITH 240 VOLT HEATER
	ITEM NUMBER		ITEM NUMBER
1/2	SSBT4517T107	7/8	SSBT4517T207
	SSBT4517T113	1 1/8	SSBT4517T213
3/4	SSBT6517T107	7/8	SSBT6517T207
	SSBT6517T113	1 1/8	SSBT6517T213

Replacement Stripper Bushings

ITEM NUMBER*	L
SSSB07	7/8
SSSB13	1 1/8

*Includes mounting screws.

Typical Application

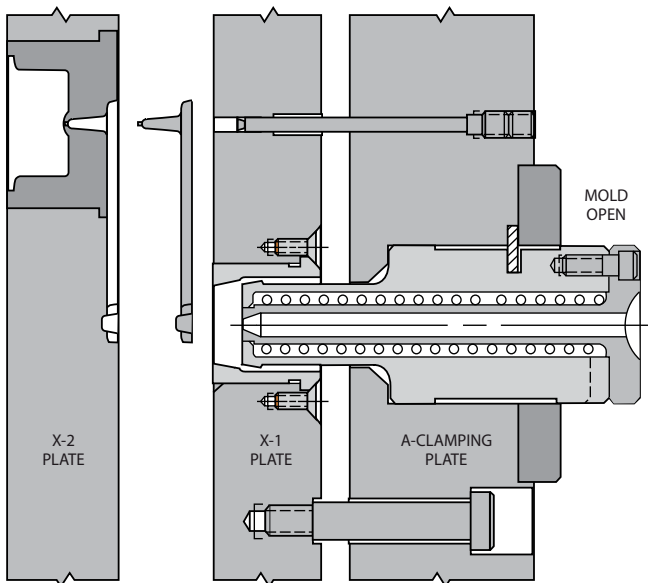

For Improved Performance and Increased Productivity:

- Use DME standard T-Series (3-Plate) Mold Bases (See DME Mold Bases and Plates Catalog)

TR-Series Straight Shot®



NOTE:

The expansion factor must be taken into consideration prior to machining for and installation of the bushing. This factor (BE) must then be added to the A dimension. The formula for determining this expansion factor is as follows:

$$BE = "A" \text{ dimension} \times 0.0000633 \times \text{nozzle set point} - 68^\circ\text{F}$$

(assuming the mold is at 68°F during operation). If mold temperature is different, substitute 68°F with actual mold temperature.

EXAMPLE:

Given a setpoint of 500°F:

$$BE = 1.375 \times 0.000063 \times (500 - 68) = .004 \text{ thus } 1.375 + .004 = 1.379.$$

Please note that the above information is given as an example. Variations may occur based on mold configuration and cooling factor. In some instances, it may be necessary to obtain an empirical factor.

TR-Series Straight Shot Hot Sprue Bushings

R	WITH 120 VOLT HEATER	L	WITH 240 VOLT HEATER
	ITEM NUMBER		ITEM NUMBER
1/2	SSBT4517TR107	7/8	SSBT4517TR207
	SSBT4517TR113	1 3/8	SSBT4517TR213
3/4	SSBT6517TR107	7/8	SSBT6517TR207
	SSBT6517TR113	1 3/8	SSBT6517TR213

NOTE:

5° heater lead is standard. For 90° lead, add "90" to end of item number (e.g., SSBT4517TR10790).

Typical Application

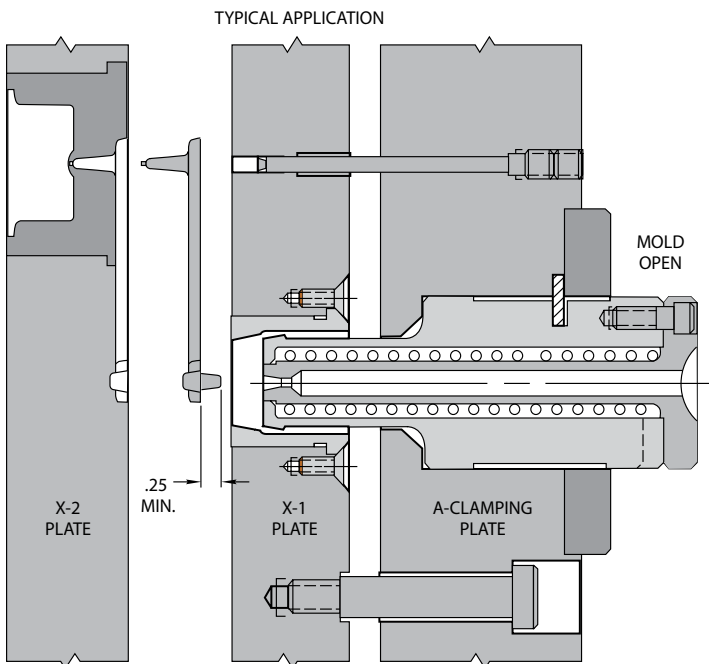

The DME standard TR-Series Straight Shot® Hot Sprue Bushing, like the standard T-Series, improves the performance of three-plate runner molds by minimizing the length of protrusion on the runner system. This bushing features a "reverse taper" design that originates from under the heat source, providing easier start-ups.

The TR-Series design can also be used when a reverse taper will benefit a particular application. The bushing is supplied with a .12 diameter orifice and a .25 long reverse taper. The orifice may be enlarged and the taper increased to suit. The bushing is available with either 1/2" or 3/4" spherical radius, 120 or 240 volt heater and a 7/8" or 1 3/8" long stripper-plate bushing to suit the application.

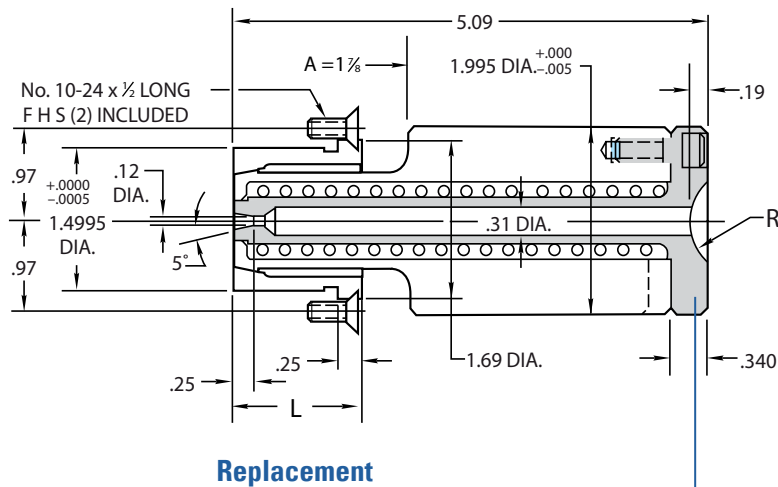

Replacement Cores

ITEM NUMBER	SPH.RAD.
SSC45R	.500
SSC65R	.750

Important:

To prevent "pushback" of the hot sprue bushing due to injection pressure – and assure a positive tapered seal with the stripper plate bushing – secure the hot sprue bushing to the A-Clamping Plate. A dowel or flat key installed under the locating ring (shown) or clamping-type locating ring may be used.

Straight Shot® Bushings Replacement Parts

Replacement Heaters for Straight Shot Hot Sprue Bushings Standard

ITEM NUMBER*	VOLTS	WATTS	L	BUSHING SERIES
SSTC31	120	300	4 $\frac{5}{8}$ "	S, E & ER (Long Style), T & TR
SSTC32	240	300	4 $\frac{5}{8}$ "	S, E & ER (Long Style), T & TR
SSTC42	240	250	2 $\frac{1}{2}$ "	E & ER (Short Style)

* Includes installation wrench.

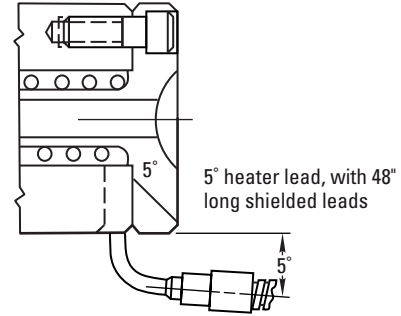

Straight Shot Heater Installation and Removal Wrench

(Included with heaters above).

ITEM NUMBER	USED WITH
WR0875	SSTC31 & 32 Series
WR0874	SSTC42 Series

Available On Request:
Heaters with 90° exit leads. Add "90" to item number.
Example: SSTC3190

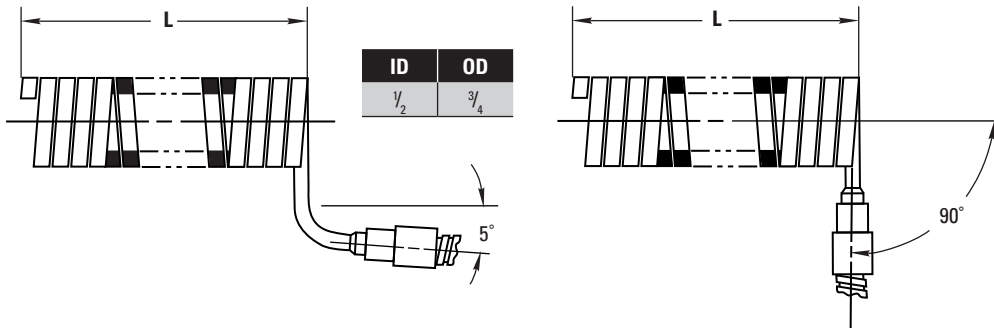

Replacement Parts for Discontinued Hot Sprue Bushings (HBT6630 through 6636), Temperature Controllers (PFC5) and Control Modules (FC5)

Cartridge Heaters

DIA.	LENGTH	WATTS	VOLTS	ITEM NUMBER
1/4"	2 $\frac{1}{2}$ "	240	200	
1/4"	3 $\frac{3}{4}$ "	240	300	HBC2032**

* Used with Hot Sprue Bushings 5 $\frac{3}{16}$ " long; heater supplied with leads 48" long.

** Used with Hot Sprue Bushings 6 $\frac{3}{16}$ " long; heater supplied with leads 46" long.

Thermocouple Cartridge Heaters

DIA.	LENGTH	VOLTS	WATTS	ITEM NUMBER
1/4"	2 $\frac{1}{2}$ "	240	200	HBTC2022*
1/4"	3 $\frac{3}{4}$ "	240	300	HBTC2032**

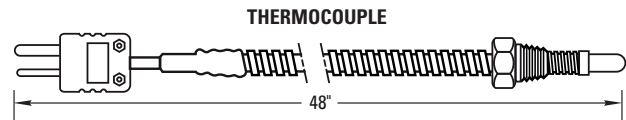

Threaded type thermocouple is spring loaded and supplied with cable and mini plug.

ITEM NUMBER
TCT4

ITEM NUMBER	AMPS
ABC5	5
13X5	5

Replacement Fuses for Temperature Control Modules (FC5) and Temperature Controllers (PFC5)

See the DME Control Systems Catalog for new controllers.

Integrally Heated Sprue Bushings .750" SERIES

The **Integrally Heated Sprue Bushing** is uniquely designed for high performance and reliability for direct gating applications, even with the most demanding molding cycles and plastic resins.

The product's advanced heat transfer capability is attributed to its integrally heated design, resulting in a more uniform heat profile. Maximum heat 600°F.

A replaceable thermocouple is strategically located near the melt flow channel to optimize processing conditions with all thermoplastics.

Features and Benefits:

- **Distributed watt density** – maintains a more uniform heat profile.
- **High refractory insulation** – provides superior heat transfer.
- **Streamlined flow channel** – minimizes pressure loss.
- **Fully sealed construction** – maintains highest product reliability.
- **High-grade alloy steel construction** – increases durability and longer life.
- **Replaceable thermocouple** – allows for Type "J" or "K".



Tip Styles and Flow Diagrams

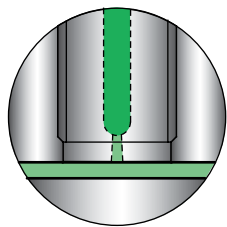

Sprue Tip

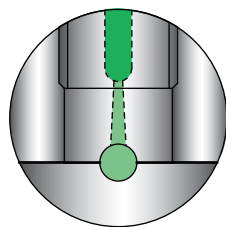

Extra Stock Sprue Tip

Maximum heat 600°F

**Recommended for
Commodity Resins
Only**

Direct Gating Diagram

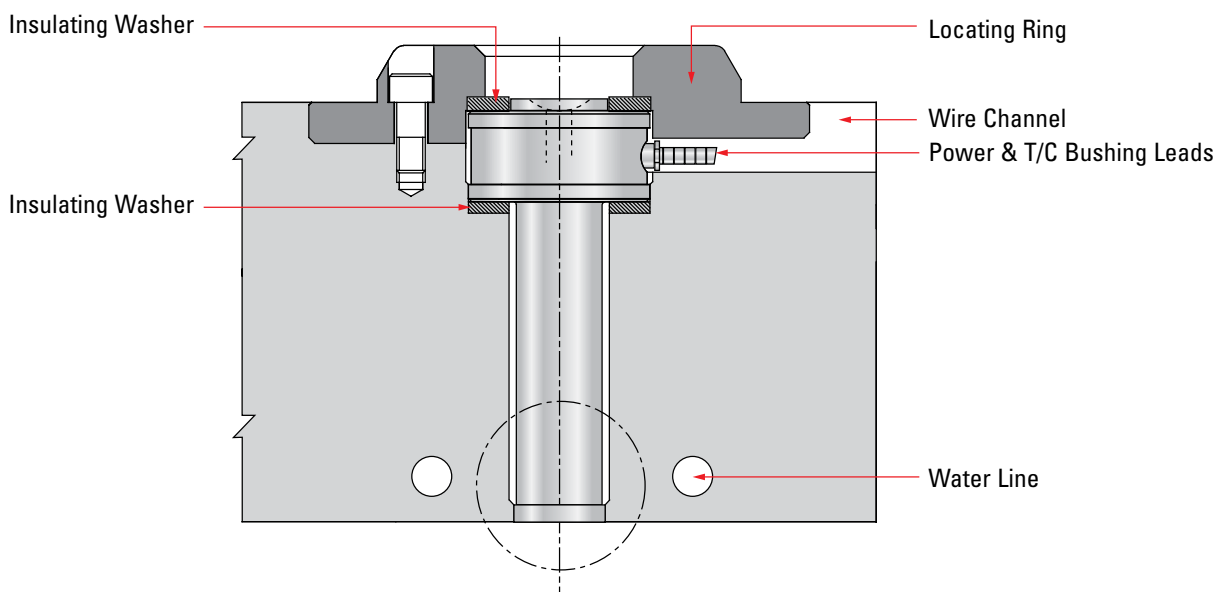

Integrally Heated Sprue Bushings .750" SERIES USER GUIDE

Integrally Heated Sprue Bushings

The DME Integrally Heated Sprue Bushing is an exclusive medium volume bushing with the ability to process a wide range of resins. Its streamlined flow channel terminates in a reverse taper gate, providing minimal pressure loss and allowing for rapid gate freeze. The formation of a small gate stub on the part or runner results in a machine hold-time reduction, with no increase in sink marks on the part.

The Sprue Bushing's superior heat transfer capacity is attributed to its integrally heated design. To optimize processing conditions for all thermoplastics, a replaceable thermocouple is strategically located near the flow channel. The Integrally Heated Sprue Bushing has a .187" flow diameter, and is offered in two head styles and two gate styles to suit a broad range of applications.

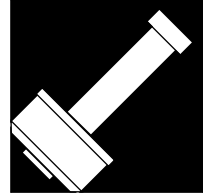

Gating Options for Sprue Bushings

SPRUE GATE

Suitable for most applications, the Sprue Gate is provided as standard on the Heated Sprue Bushing. **(Please note that this gate style is not intended for machining.)** The press fit areas are held to $\pm .0005"$.

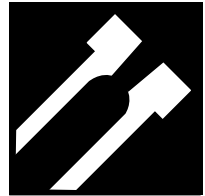

EXTRA STOCK SPRUE GATE

The Extra Stock Sprue Gate is available for applications requiring machining of the gate area for runner profiles, part contours, or adjustment of the bushing height. The .750" diameter bushing has .500" of extra stock. The press fit areas are held to $\pm .0005"$.

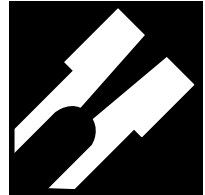

Head Options for Sprue Bushings

.500" Radius*

Provided with a 0.500" radius to mate with 0.500" radius machine nozzles. Reinforced contact area for improved strength and heat transfer.



.750" Radius*

Provided with a 0.750" radius to mate with 0.750" radius machine nozzles. Reinforced contact area for improved strength and heat transfer.



***Other radii are available by special request.**

Gating Options	Gate Diameters
Sprue	.080" to .125"* max. (2mm to 3.2mm* max.)
Extra Stock Sprue	.080" to .125"* max. (2mm to 3.2mm* max.)

* Re-machine gate diameter, if necessary, for larger shot weights. Maintain gate angle and remove all machine marks.

.750" Series Maximum Shot Weights (0.080" Gate)

Gating Options	Resin Viscosity		
	High	Medium	Low
Sprue	50g	150g	300g
Extra Stock Sprue	50g	150g	300g

Contact DME when exceeding minimum shot weight and process heat temperature at 600°F.

Reference: High Viscosity = Melt Flow (0.02 – 6); Medium Viscosity = Melt Flow (7 – 15); Low Viscosity = Melt Flow (16 – up). The values expressed in grams are for reference purposes only. Part dimensions, wall thickness, mold condition, and molding parameters must also be considered.

.750" Series Resin Compatibility

Gating Options	Commodity Resin
Sprue	⚡
Extra Stock Sprue	⚡

⚡ = Recommended

Integrally Heated Sprue Bushings .750" SERIES

Head Options

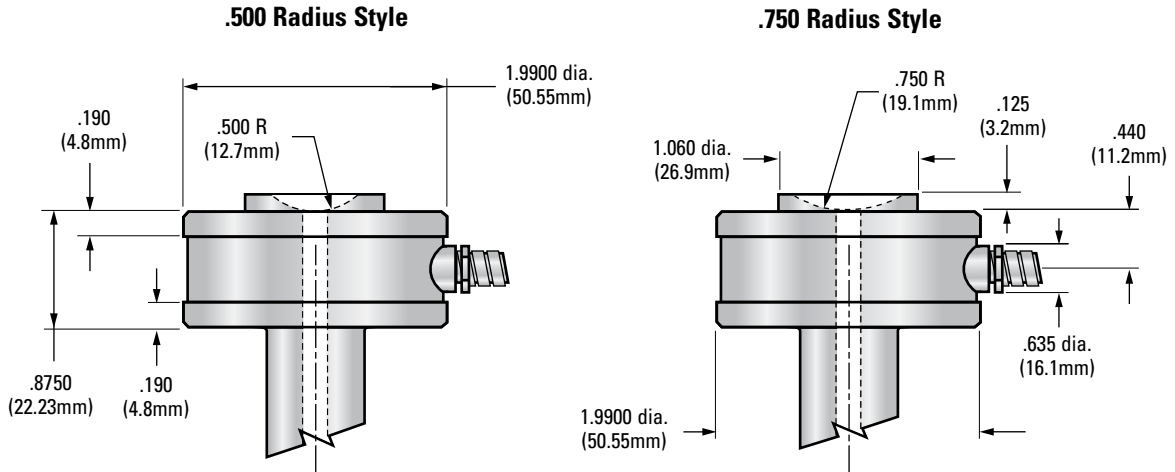

Gating Options / Bushing Dimensions

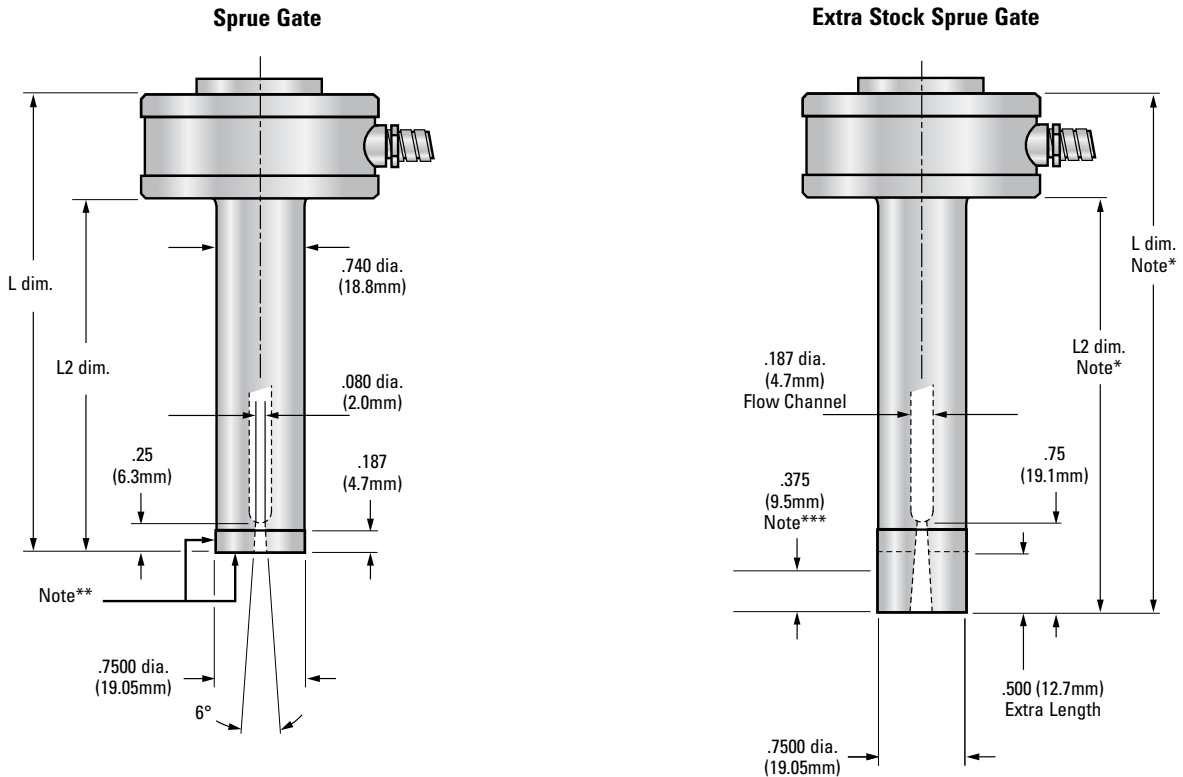

* Dimensions include extra length.

** This surface cannot be machined, modified or altered.

*** Maximum machining stock; only this area can be machined.

Dimensions are in inches; millimeters are in parentheses.

Note: For additional gate dimensions see page 82

Integrally Heated Sprue Bushings .750" SERIES SPECIFICATIONS

Integrally Heated Sprue Bushing - 750 Series

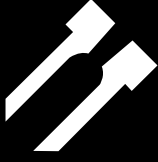
Gate Style	L Dim.		L2 Dim.		.500 Radius Head	.750 Radius Head	Watts	Thermocouple
 Sprue	2.375"	(60.3)	1.500"	(38.1)	SB031000	SB031001	315	MT020020
	2.875"	(73.0)	2.000"	(50.8)	SB031008	SB031009	370	MT020020
	3.375"	(85.7)	2.500"	(63.5)	SB031016	SB031017	425	MT020020
	3.875"	(98.4)	3.000"	(76.2)	SB031024	SB031025	480	MT020020
	4.375"	(111.1)	3.500"	(88.9)	SB031032	SB031033	535	MT020021

Gate Style	L Dim.		L2 Dim.		.500 Radius Head	.750 Radius Head	Watts	Thermocouple
 Extra Stock Sprue	2.875"	(73.0)	2.000"	(50.8)	SB031004	SB031005	315	MT020020
	3.375"	(85.7)	2.500"	(63.5)	SB031012	SB031013	370	MT020020
	3.875"	(98.4)	3.000"	(76.2)	SB031020	SB031021	425	MT020020
	4.375"	(111.1)	3.500"	(88.9)	SB031028	SB031029	480	MT020020
	4.875"	(123.8)	4.000"	(101.6)	SB031036	SB031037	535	MT020021

All specifications are subject to change without notification.
Dimensions are in inches; millimeters are in parentheses.

Right (Standard)*

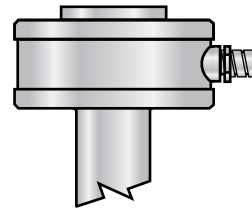

* Standard Lead exit –
60" (1.52m) wrapped - 600 volt leads;
right angle lead exit; and 6" (15.2cm)
stainless steel, square-lock armored cable.

ITEM NUMBER

CKPTIC1

**Mold Power-Thermocouple Input Connector**

A Single-Zone Power-Thermocouple Input Connector is available for mounting in or on the mold to accept the power-thermocouple cable from the mainframe. The water-resistant connector has an integral retaining latch for a secure cable connection and numbered screw-type terminals for power and thermocouple lead wires.

*Can be mounted on top of mold

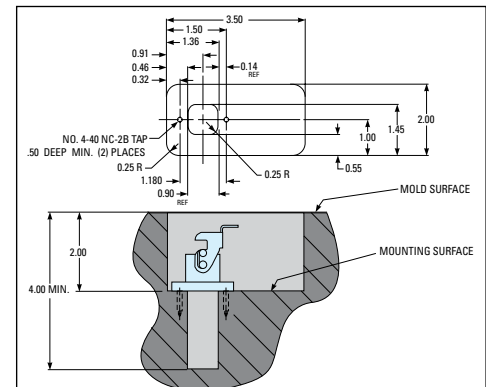
Recommended Mold Pocket Layout For Mold Power-Thermocouple Input Connector (CKPTIC1)

ITEM NUMBER

MPTC10

MPTC20

**Armored Mold Power-Thermocouple Cables**

Single-Zone Mold Power-Thermocouple Cables are constructed of special lead wire for use in high temperature environments, and are available to connect the mainframe to the input connector on the mold. Available in lengths of 10 or 20 feet. Integral retaining latches on the mainframe and mold connections provide secure cable connections. Connector configurations ensure proper insertion of cable.

For complete information on temperature controls, please see DME Control Systems Catalog.

U.S. 800-626-6653 ■ Canada 800-387-6600 ■ dme.net ■ store.dme.net

Integrally Heated Sprue Bushings .750" SERIES

.750" Series Bore & Gate Dimensions

Insulating Washer Specifications

	Top	Bottom
Item Number	MAX10015	MAX10027
O.D.	1.99 (50.5mm)	1.99 (50.5mm)
I.D.	1.07 (27.2mm)	.810 (20.6mm)
Thickness	.125 (3.2mm)	.125 (3.2mm)

Note: Insulating Washers are not required, but are recommended for high temperature applications.

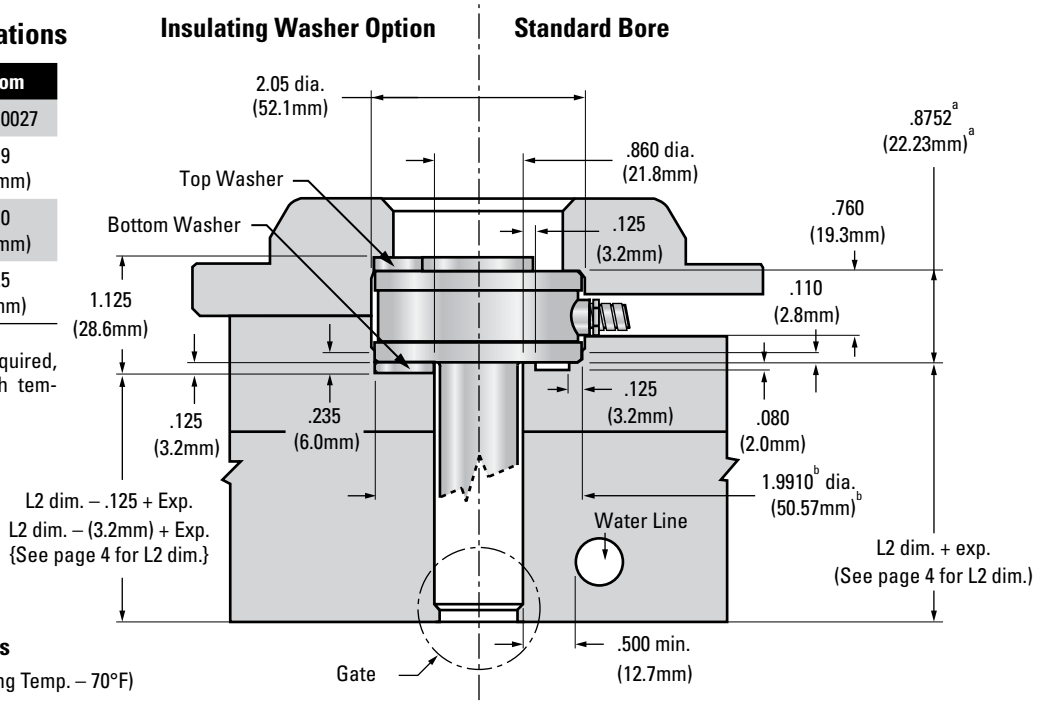

Thermal Expansion (Exp.) Formulas

$$\text{Exp. in} = \text{L2 in.} \times 6.88 \times 10^{-6} \times (\text{Processing Temp.} - 70^\circ\text{F})$$

$$\text{Exp. mm} = \text{L2 mm} \times 13 \times 10^{-6} \times (\text{Processing Temp.} - 21^\circ\text{C})$$

Ref: $10^{-6} = 0.000001$

All specifications are subject to change without notification.

Sprue Gate

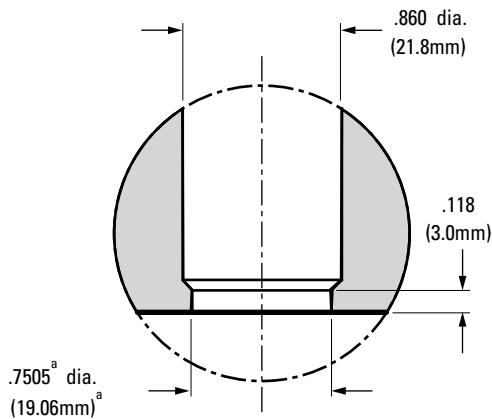

Extra Stock Sprue Gate

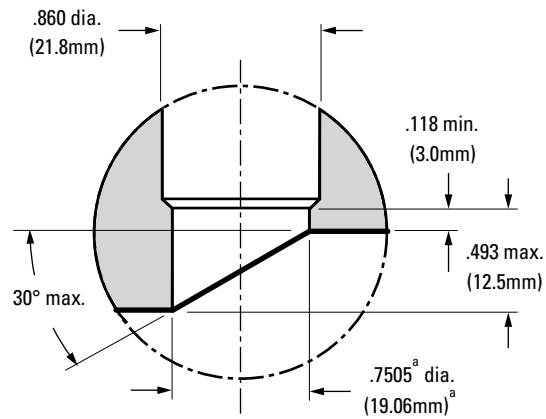

Bore & Gate Tolerances

Tol. "a" Table	
in:	+ 0.0005 - 0
mm:	+ 0.01 - 0

Tol. "b" Table	
in:	+ 0.0010 - 0
mm:	+ 0.02 - 0

Dimensions are inches. Millimeters are in parentheses.

Integrally Heated Sprue Bushings .750" SERIES

Operating & Servicing Instructions

The Integrally Heated Sprue Bushing bodies are identical in design, but differ in length and head style. All Sprue Bushings feature an integrated heater; Type "J" thermocouple; 60" wrapped - 600 volt leads; right angle lead exit; and 6" stainless steel, square-lock armored cable.

Start-Up/Operating Procedures

If the temperature controller does not utilize "soft start" technology, set the controller to 200°F (93.3°C) in automatic mode or 10% in manual mode. Allow bushing to "soak" for 15 minutes before increasing to processing temperature. This step will allow the unit to dissipate potential moisture and prolong heater life.

Power Requirements

- 240 Volts AC – 15 amp fuse
- Grounding – Integrally Heated Bushings utilize the direct contact of the bushing, mold plates, and machine platens to establish a path for grounding.

WARNING

There must be a ground \equiv present between the mold "hot half" and the temperature control system or damage may occur to the bushing, thermocouple and/or temperature control system.

Maximum heat 600°F

Locating Ring Dimensions

ITEM NUMBER	L.R.D.
ML010012	3.990" (101.3mm)

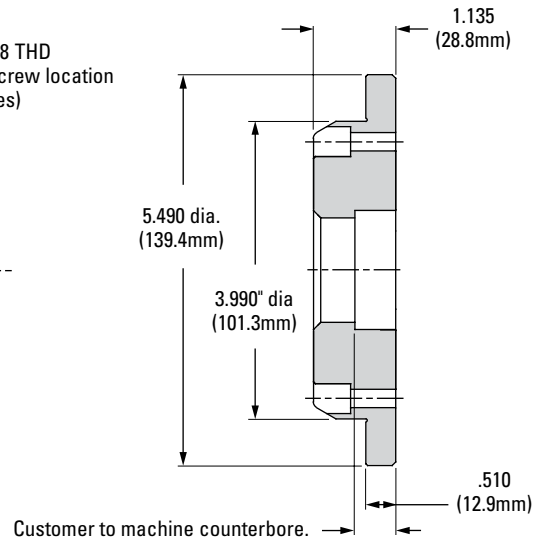
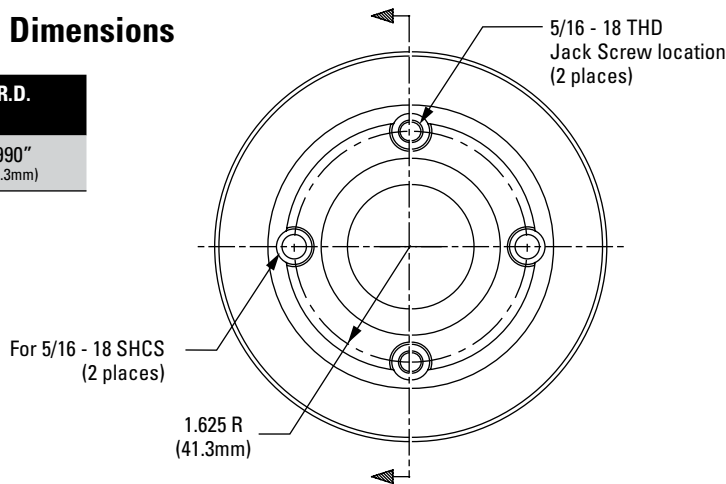

Machining Options for Keying

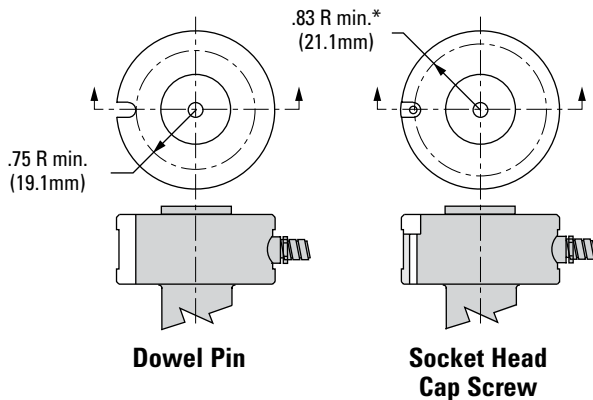

*Centerline for #10 Screw

Dimensions are in inches; millimeters are in parentheses.

DME Hot Runner Services

TOTAL SUPPORT FOR YOUR
HOT RUNNER SYSTEMS

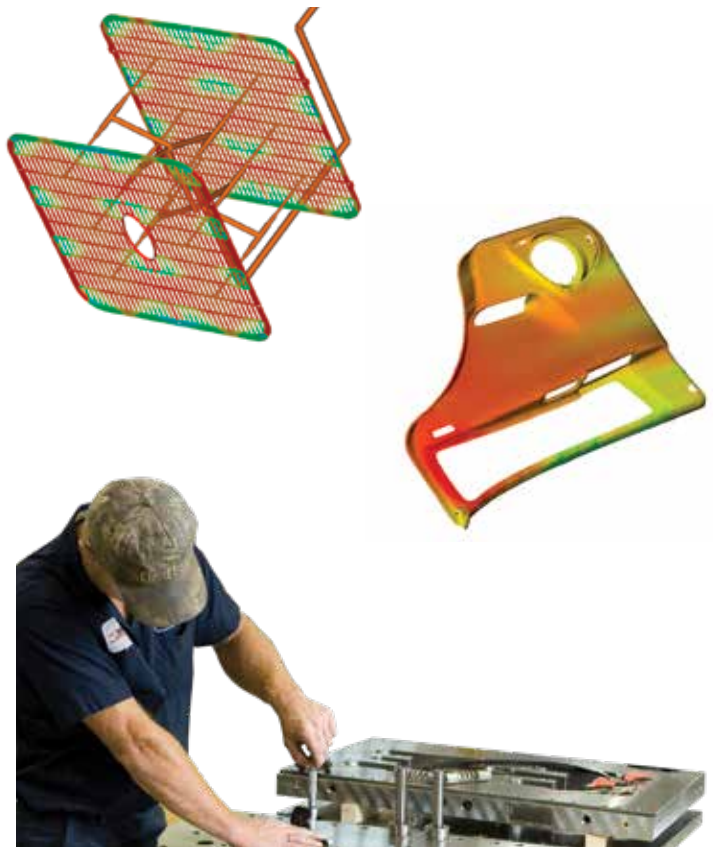

Moldflow Services — Optimize Part and Mold Design

[Hot Runner Services](#)

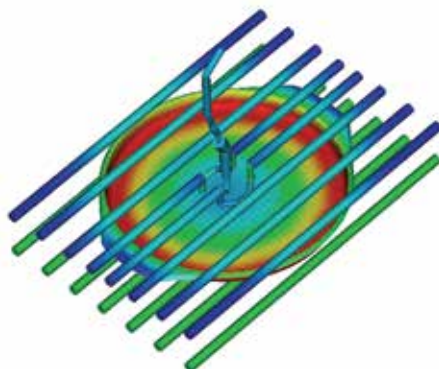
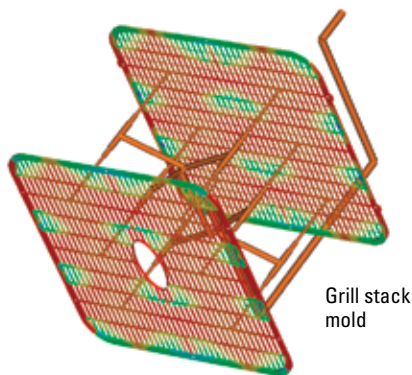
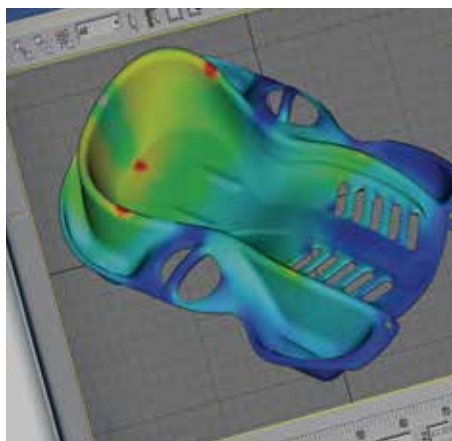

Comprehensive Analysis and Modeling

With today's shrinking time-to-market window, development speed is essential. As part of its commitment to the molding industry, DME is now offering Moldflow™ analysis to help optimize part and mold design – especially for hot runner molds. DME is the first mold technologies supplier to earn Moldflow's silver certification in this advanced technology.

A Competitive Advantage

Predictive analysis, utilizing Moldflow software, yields tremendous benefits, including:

- Optimize part design
- Reduce time-to-market
- Save cost and time on mold tryouts
- Lower development and production costs
- Provide a framework to establish reputable processes
- Improve product quality
- Decrease cycle times

What is Moldflow?

DME uses Moldflow Plastics Insight™ (MPI) software which is an integrated suite of analysis tools that utilize CAD files and apply advanced Finite Element Analysis (FEA) techniques to quickly and easily enable a virtual "what if" design environment before initiating mold construction. MPI provides in-depth part/mold design and process parameter optimization. This is in contrast to Moldflow Plastics Advisor™ (MPA) which is primarily useful for parts with low to medium complexity, conceptual designs, and quick part design validation. DME is a certified, licensed provider of Moldflow analysis services.

Mold Fill Analysis

The Mold Fill module uses predictive technology to simulate the filling process. Key analyses include:

- Optimize the number, size, and location of gates
- Balance the runner system design
- Reduce material stress levels
- Predict weld line locations
- Validate pressure and temperature distribution within the mold
- Optimize processing conditions – including melt temperature, injection rate, and cavity pressure

Moldflow Services — Optimize Part and Mold Design

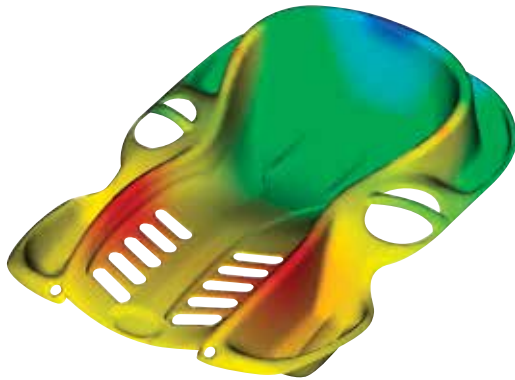

Mold Pack Analysis

Building on the results of a Mold Fill analysis, the Mold Pack module optimizes the packing phase to ensure a uniform packing condition. As an indication of part warpage, volumetric shrinkage is evaluated and the pack pressure profile is optimized. The result is minimized warpage with an improved surface appearance.

Mold Cool Analysis

The Cool Analysis module assesses an existing cooling layout to determine potential molding problems. Steel types, cooling channel sizes, bubblers, baffles, coolant temperatures, and flow rates are all evaluated. Using this analysis, the Mold Cool module recommends practical tooling design changes to ensure uniform cooling. Mold Cool takes into account:

- Number, location, depth, and pitch of cooling channels
- Steel types
- Cooling circuit layouts
- Coolant temperatures and flow rates
- Cycle times

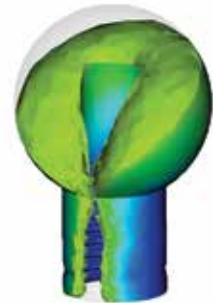
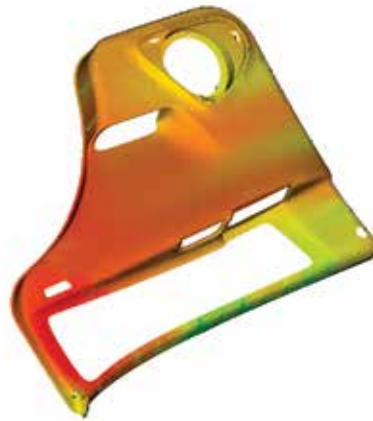

Warp Analysis

Using the results from the Fill and Cool analyses, the Warp Analysis module enables prediction of plastic part shrinkage and warpage. Warp Analysis diagnoses the cause(s) of warping and recommends the appropriate solution, such as gate location changes, design parameter changes, and reduction of wall thickness variations.

MPI 3D

MPI 3D addresses a class of problems previously unsolvable using traditional Finite Element Analysis techniques. In thick-walled parts, molten plastic can flow in all directions. Using a proven methodology based on a solid tetrahedral, finite element volume mesh, MPI 3D enables true, three-dimensional simulations on thick-walled parts.

Where Do I Start?

Contact your DME representative for more information regarding Moldflow Services. The DME Applications Engineering Department is available to provide a customized Moldflow analysis and assist you in maximizing the results of your next application.

Mold Filling/Mold Cooling Analysis Quote Request Form

THIS FORM IS REQUIRED FOR ALL ANALYSIS WORK FOR EACH PART

NOTE: Changes made after this form is received require written confirmation

[Online Form](#)

Fax completed form to 248-544-5707 or
email dme_appl_eng@dme.net

 CUSTOMER REQUEST FOR DATA Mold Filling / Mold Cooling Analysis	
(THIS FORM IS REQUIRED FOR ALL ANALYSIS WORK FOR EACH PART) NOTE: CHANGES MADE AFTER THIS FORM IS RECEIVED REQUIRE WRITTEN CONFIRMATION	
AE002.1 Rev: 11/5/14 Fax completed form to: 248-544-5707 or email: dme_appl_eng@milacron.com	
Customer:	Date:
	P.O. #:
Phone:	Job #:
Fax:	Project Engineer:
Resin Supplier:	Contact:
Phone:	
Mold Maker:	Contact:
Phone:	
Manifold Supplier:	Contact:
Phone:	
PART INFORMATION	RESIN INFORMATION
Part Name:	Resin Type:
Part Number:	Resin Grade:
Nominal Wall:	Melt Index:
Part Weight:	Max Flow length:
Gate Type:	Min Temp. Max. Temp.
PROTOTYPE <input type="checkbox"/> PRODUCTION <input type="checkbox"/> Mold Material: <input type="checkbox"/> P20 <input type="checkbox"/> Aluminum <input type="checkbox"/> Other	NOTES: <input checked="" type="checkbox"/> RESIN CHANGES REQUIRE WRITTEN APPROVAL <input checked="" type="checkbox"/> IN THE EVENT ABOVE MATERIAL IS NOT IN THE DATABASE, A MATERIAL AS CLOSE AS POSSIBLE WITH BE SUBSTITUTED
PROCESSING INFORMATION	MACHINE INFORMATION
Injection Time:	Flow Rate Capability (in ³ /sec):
Cycle Time:	Clamp Force (Press Size):
Mold Temperature:	Injection Pressure:
Melt Temperature:	Number of Cavities:
Cooling Water Temp:	Is there a water manifold?
Cooling Time:	
MOLDFILLING OBJECTIVE	MOLDCOOLING OBJECTIVE
Balance Filling Pattern <input type="checkbox"/>	Optimize Cycle Time <input type="checkbox"/>
Determine Optimal Gating <input type="checkbox"/>	Optimize Cooling Time <input type="checkbox"/>
Minimize Wall Thickness <input type="checkbox"/>	Reduce Warpage <input type="checkbox"/>
Evaluate Knit Lines <input type="checkbox"/>	Evaluate Existing Mold <input type="checkbox"/>
TIME SCHEDULE	
Molding Trial Date:	Molding Facility:
Manifold Locations due by:	Manifold/Drop Information due by:
Cold Runner Information due by:	Water Line Information due by:

COMMENTS:

This form was filled out by _____
Please sign and date: _____

DME Company ■ 29111 Stephenson Highway ■ Madison Heights ■ MI ■ 48071
Phone 248-398-6000 ■ DME@dme.net

U.S. 800-626-6653 ■ Canada 800-387-6600 ■ dme.net ■ store.dme.net

DME Service Centers

Ensuring the Productivity of every Hot Runner System

Full-Service Hot Runner Support

Mold technology leader DME - known for servicing its customers every step of the way - provides total support for your hot runner systems. No matter what brand of hot runner, DME will repair, reconfigure or even totally rebuild it to ensure maximum performance of your system.

A Dedicated Center for Hot Runner Systems

Our Service Center, located in Madison Heights, Mich., is exclusively dedicated to supporting your hot runner systems. Staffed by a team of industry experts whose sole focus is hot runner systems, we aim to provide optimal repair and troubleshooting to maintain and get your system operating at maximum efficiency. This group has over three decades of experience installing, assembling, and repairing hot runner systems. And, our dedicated staff will get your system back into your facility quickly and cost-effectively. Please contact us for other service center locations.

Hot Runner Services Overview

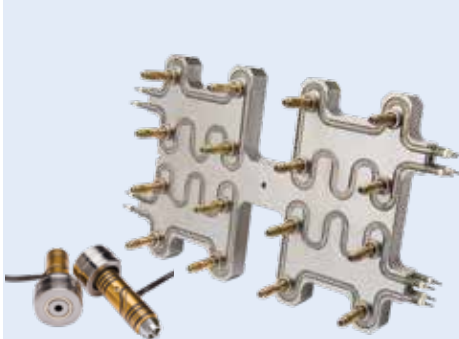

The DME family of hot runner products and services offers a comprehensive array of solutions for a wide range of applications.



Unrivalled Support When and Where You Need It

Since the 1970s, DME has developed and marketed a full spectrum of hot runner systems and components. From Moldflow analysis to turnkey hot half systems and everything in between, the DME family of hot runner products and services offers a comprehensive array of solutions for a wide range of applications. Whether your need is for standard, off-the-shelf components, customer engineered manifolds, or fully assembled systems ready for bolt-on installation, DME has a proven solution to match your application.

Moldflow Services

As the first mold technologies supplier to earn Moldflow's silver certification, DME is highly adept at applying Finite Element Analysis (FEA) techniques to help optimize part and mold design. Whether you need Mold Fill, Mold Pack, Mold Cool or Warp analyses, DME can assist you in maximizing the results of your next application.

Applications Engineering and Technical Service

Our dedicated and experienced team of mold designers, technicians and applications engineers assists DME customers with product selection, system design, performance analysis and technical advice. DME technical service representatives are globally located for complete coverage and quick availability no matter where your hot runner production takes place. Technical experts employed worldwide are available for start-ups, personnel training or system service.

Comprehensive Hot Runner and Aftermarket Service

Staffed by a team whose sole focus is hot runner systems, the DME Hot Runner Service Center offers a single source for hot runner system optimization and maintenance. Our services include expedited repairs, system cleaning, system rebuilds, re-configuration and refurbishment for virtually any type of hot runner system.

DME Service Centers

A Wide Range of Services

We recognize the value of your time - that's why we've developed a comprehensive suite of hot runner services to provide a single source for maintenance and optimization of your system.

Key capabilities and services include:

- System evaluations
- Repairs - systems and components
- System cleaning and rewiring of all hot runner systems - including complete bake-out
- Total system rebuild/reburishment
- Re-configuration
- Operating training
- All machining capabilities
- Processing support

Cost-Effective Reconfiguration

When your process needs change, without a significant tooling change, we can adapt your hot runner to the new process. Whether it's a material switch, or a part design change, DME can help reconfigure your existing system.

Training Maximizes Productivity, Speeds Set-Up

The DME Hot Runner Service Center and technicians can provide comprehensive operator training from start-up to production processing. Our hands-on programs help your operators get up-to-speed, or stay current on hot runner technology.

Preventative Maintenance (PM)

It is important to protect and update your hot runner system to ensure it is running at the highest efficiency. The PM Program is designed to provide life cycle management of your systems and enhance equipment reliability by:

- Replacing worn components before they fail
- Maximizes system performance
- Reduces cost of replacement
- Ensures peak part quality
- Decreases system downtime
- Protects your investment

The PM Program can be set up either by system cycles or by scheduled PM

Rebuilds Ensure Performance

After tens of thousands of cycles you may have noticed your system just doesn't perform the way it used to. Or maybe you've run high-temperature engineered materials and the tolerances just aren't as tight. Key benefits of system rebuilds include:

- Cost savings of at least 40% as compared to new systems
- Extended life for your tool
- Maximizing system uptime and performance

Whether you need a total system rebuild, or a simple cleaning and inspection DME can help. System rebuilds can be performed on any brand of hot runner system and typically include:

- Complete bake-out cleaning
- Check and replace heaters and thermocouples
- Inspect and correct wiring
- Replace seals, bushings and other wear items
- Clean or replace nozzle components
- Check and validate all dimensions before re-assembling the system

Repairs Get You Back Up Quickly

Time is money. When a critical tool is out of commission, productivity is lost and production schedules can be threatened. We understand this at DME. That's why our team of hot runner technical specialists are always available to get you back in service.

Whether you're experiencing leaks, heating issues, flow problems, or would simply like a system bake-out, we'll repair your system quickly and cost-effectively.

Standard turnaround for repairs on systems from 1-12 drops (depending on parts availability for non-DME systems) is 5 working days or less. If your system has over 12 drops, contact us for an estimated turnaround time. And, we offer emergency 24-hour service.

Mold Tryouts

Our Technical specialists can also support your mold tryouts to optimize hot runner performance.

DME Obsolete Replacement Parts

REPLACEMENT PARTS FOR OBSOLETE
HOT RUNNER SYSTEMS & NOZZLES



Mini Gate-Mate® Nozzles

NOZZLE SUB-ASSEMBLY (ORDER TIP SEPARATELY)		INCLUDES				
		1	2		3	4
ITEM NUMBER	HEATER TYPE	NOZZLE BODY	HEATER	WATTS	THERMO-COUPLE	SEAL RING
GMB0110	CAST-IN	GMB0105	CIH0100	250	N/A (INTEGRAL)	EHR7155
GMB0118	SQUARE COIL	GMB0105	SCH0004	250	TCG0100	

1/2" SPH. RADIUS BUSHING SUB-ASSEMBLY		FLAT BUSHING SUB-ASSEMBLY	
ITEM NUMBER	HEATER TYPE	ITEM NUMBER	HEATER TYPE
GMB0116	SQUARE COIL	GMB0117	SQUARE COIL
GMB0111	CAST-IN	GMB0112	CAST-IN

Mini Gate-Mate® Tips

Contact DME for tip recommendations and assistance with your application.

ITEM NUMBER	TIP STYLE
GMT0100	STANDARD
GMT4101	WEAR RESISTANT

Mini Gate-Mate Bushing Locating Ring

ITEM NUMBER
6548

Gate-Mate® 4 Nozzles and Tips

[Obsolete Replacement Parts](#)

A	NOZZLE ASSEMBLY (INCLUDES GMT2 TIP)	NOZZLE SUB ASSEMBLY (TIP ORDERED SEPARATELY)	INCLUDES				
			1	2		3	4
			NOZZLE BODY	SQUARE COIL HEATER	WATTS	THERMO-COUPLE	SEAL RING
2.000	GMB0050	GMB0150	GMB0060	SCH0060	250	TCG0060	EHR7155
2.500	GMB0051	GMB0151	GMB0061	SCH0061	300	TCG0061	
3.000	GMB0052	GMB0152	GMB0062	SCH0062	350	TCG0062	
3.500	GMB0053	GMB0153	GMB0063	SCH0063	400	TCG0063	
4.000	GMB0054	GMB0154	GMB0064	SCH0064	425	TCG0064	
5.000	GMB0055	GMB0155	GMB0065	SCH0065	500	TCG0065	
6.000	GMB0056	GMB0156	GMB0066	SCH0066	500	TCG0066	

NOTES:

- Items 1 thru 4 are available separately for replacement purposes
- Items 2 is 240 VAC, 36" leads, 34" fiberglass lead protection
- Item 3 is type J, with 36" leads, 34" fiberglass lead protection
- Item 4 (for replacement) is sold in packs of 4 only

INCLUDES			
1	2		3
NOZZLE BODY	FRONT LOAD HEATER	WATTS	SEAL RING
GMB0060	SCH1060	250	EHR7155
GMB0061	SCH1061	300	
	SCH2061		
GMB0062	SCH1062	350	
	SCH2062		
GMB0063	SCH1063	400	
	SCH2063		
GMB0064	SCH1064	425	
	SCH2064		
GMB0065	SCH1065	500	
	SCH2065		
GMB0066	SCH1066	500	
	SCH2066		

NOTES:

- Items 1, 2 and 3 are available separately for replacement purposes
- Item 2 is 240 VAC, type J thermocouple, 36" leads, 34" Teflon lead protection
- Item 3 (for replacement) is sold in packs of 4 only

Replacement Seal Rings

ITEM NUMBER
EHR7155

Gate-Mate® 4 Tips

TIP STYLE	TIP ITEM NUMBER	O DIA.	TIP LENGTH	TIP DIA.	HOLE DIA.
STANDARD	GMT2	.044 MIN.	1.730	.024	N/A
WEAR RESISTANT	GMT0400	.055 MIN.			
SUPER SHARP	GMT0301	.030 MIN.			
SUPER SHARP WEAR RESISTANT	GMT0401	.055 MIN.	1.690	.010	.050
THRU HOLE	GMT0302*	.030 MIN. .050 MAX			
THRU HOLE WEAR RESISTANT	GMT0402*	.055 MIN.	1.730	.024	N/A
NO HOLE	GMT0303	.044 MIN.			

NOTES:

- Thru hole tip is designed .040 shorter in length to be a direct replacement for the standard tip; use a .030 to .060 diameter gate
- A .030 minimum diameter gate is recommended when using the super sharp tip
- Contact DME for tip recommendations and assistance with your application

*Contact DME for details to modify thru hole tips for larger "O" diameters

Gate Shell Insulators

Gate Shell Insulators

- Improves insulation in the tip area
- Provides seal-off to eliminate material degradation in threaded area of tip
- Minimizes material in gate area to allow for faster color changes
- Withstands temperatures up to 550° F



Typical Application

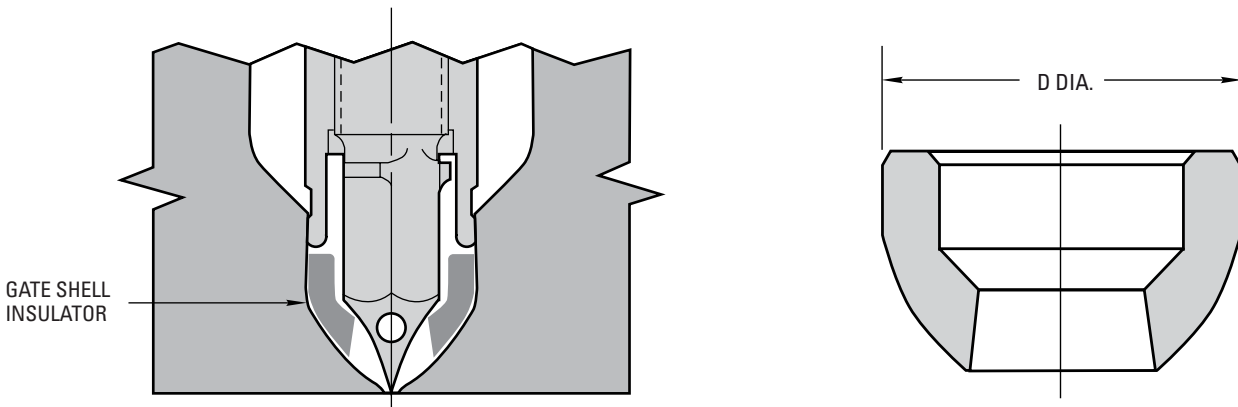

FOR BUSHING OR NOZZLE STYLE	FOR TIP STYLE	ITEM NUMBER
Gate-Mate 4 Nozzle	Standard, Super Sharp, No Hole	GSI0001
	Thru Hole	GSI0002
Jumbo Gate-Mate Bushing or Nozzle	Standard	GSI0003
	Thru Hole	GSI0004
Medium Gate-Mate Bushing	Standard, Super Sharp, No Hole	GSI0005
	Thru Hole	GSI0006

D DIA.	ITEM NUMBER
.748	GSI0001
	GSI0002
1.248	GSI0003
	GSI0004
.748	GSI0005
	GSI0006

APPLICATION NOTES:

1. Use only with bushings, nozzles and tip styles shown in the reference chart above
2. Gate machining must be done according to DME specifications
3. Nozzle tip cannot be altered in any way for the Gate Shell Insulator to perform properly
4. If dissimilar resins are to be processed in the same mold, it is recommended that their processing temperatures be within a similar range
5. For best results, the outer surface of the tip should be free from all resin before the Gate Shell Insulator is installed or used

Components for Micro Cool One® Split Plate/Solid Block Designs

Obsolete Replacement Parts

Thermocouple (T/C) Distributor Tube Heaters (240 VAC, T/C Type J, 34" Leads)

Distributed wattage heater design for more uniform temperature control. Sealed, flexible teflon covered leads to prevent lead damage and improve moisture resistance.

DIA (AMPS)*	ITEM NUMBER	OVERALL LENGTH	HEATED LENGTH	WATTS	DIA (AMPS)*	ITEM NUMBER	OVERALL LENGTH	HEATED LENGTH	WATTS
.375 (10 AMP)	HCTC034	5.000	4.000	320	.375 (10 AMP)	HCTC0375	8.500	7.500	515
	HCTC0345	5.500	4.500	340		HCTC038	9.000	8.000	550
	HCTC035	6.000	5.000	400		HCTC039	10.000	9.000	650
	HCTC0355	6.500	5.500	430		HCTC0310	11.000	10.000	710
	HCTC036	7.000	6.000	450		HCTC0311	12.000	11.000	720
	HCTC0365	7.500	6.500	470		HCTC0312	13.000	12.000	760
	HCTC037	8.000	7.000	480		HCTC0313	14.000	13.000	810

*(AMPS) = Amperage requirement for temp. control module.

Distributor Tubes

MATERIAL: AISI 4140 STEEL

HARDNESS: 28-35 HRC

ITEM NUMBER	LENGTH
HT050312	11.82
HT050316	15.76

End Cap

MATERIAL: AISI 4140 STEEL

ITEM NUMBER
EC1105

Components for Micro Cool One® Solid Block Designs

Auto-fixed® "Integral Heater" Micro Probes (240 VAC, T/C Type J, 48" Leads)

MATERIAL: AISI D-2 STEEL

HARDNESS: 50-55 HRC

ITEM NUMBER*	A	B	WATTS
AFIP331090	3.095	2.720	110
AFIP336090	3.595	3.220	130
AFIP341090	4.095	3.720	150
AFIP346090	4.595	4.220	170



NOTE: Probes are special order only

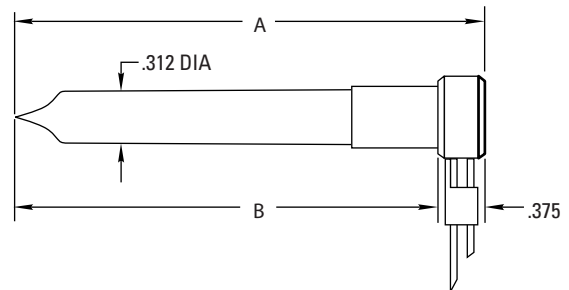

Replacement Thermocouple

ITEM NUMBER	LEAD LENGTH
TC9900	48"

Register Ring

MATERIAL: AISI H-13 STEEL

HARDNESS: 48-52 HRC

I.D. = .313

O.D. = 1.000

ITEM NUMBER*
RAF3062

*Package of 10.



The Cool One – Heated Nozzle Locator Replacement Parts

Heated Nozzle Locator Assemblies

HNL462 and HNL662 assemblies include:

- HNC46 or HNC66 core, respectively
- SSTC6290 heater
- HNS67 spacer

HNL472 and HNL672 assemblies include:

- HNC47 or HNC67 core, respectively
- SSTC7290 heater
- HNS67 spacer

R	ITEM NUMBER
1/2	HNL462
	HNL472
3/4	HNL662
	HNL672

[Obsolete Replacement Parts](#)

Cores

R	ITEM NUMBER
1/2	HNC46
	HNC47
3/4	HNC66
	HNC67



Thermocouple Heaters

(240 VAC, 250 WATTS T/C type J 36" leads)

ITEM NUMBER	USED WITH CORES
SSTC6290	HNC46 & 66
SSTC7290	HNC47 & 67



Spacer

ITEM NUMBER
HNS67



ITEM NUMBER	R
NL6702	1/2
NL6703	3/4



The Cool One – End Caps and Distributor Tubes

End Caps (for use with solid distributor block designs)

Obsolete Replacement Parts

MATERIAL: AISI 4140 STEEL

End caps provide concentricity between distributor tube and distributor bore. Thread accommodates heater stop or lead wire protector.

END CAPS FOR SPLIT PLATE DESIGNS: Moldmaker to supply to suit.

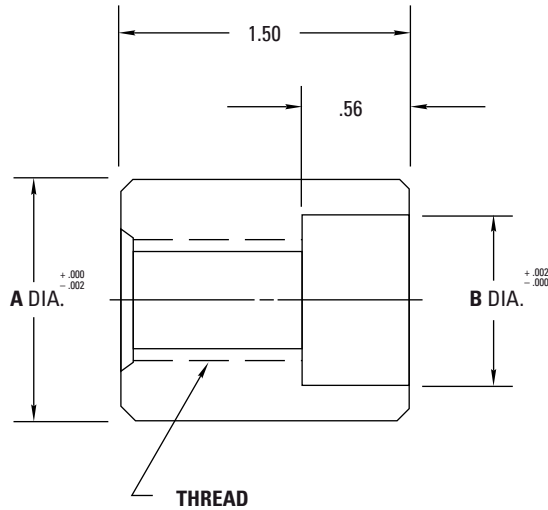

ITEM NUMBER	DIA. A	DIA. B	THREAD	USED WITH DIST. BORE/TUBE
EC1207	1.249	0.875	5/8" - 11	1.25 DIA./ .87 O.D.
EC2015	1.999	1.625	3/4" - 10	2.00 DIA./1.62 O.D.

Distributor Tubes

MATERIAL: AISI P-20 STEEL

HARDNESS: 28-35 HRC

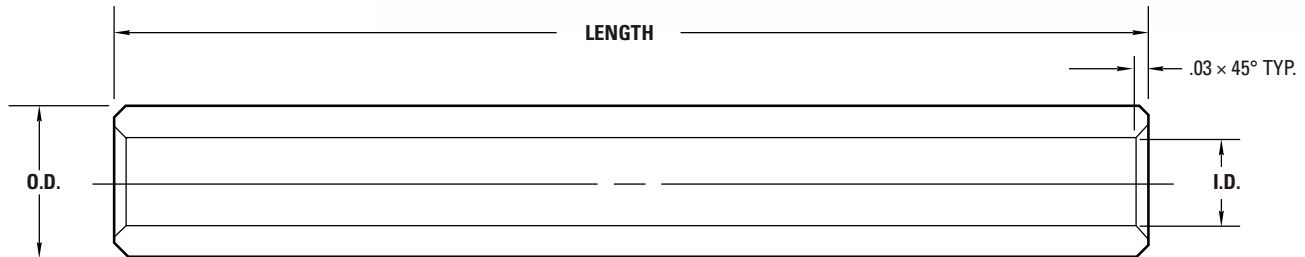

USED WITH 1.25 DIAMETER DISTRIBUTOR BORE/CHANNEL	
LENGTH	I.D. = .50 O.D. = .87
	ITEM NUMBER
6"	HT07046
10"	HT070410
16"	HT070416
20"	HT070420
24"	HT070424
29"	HT070429
34"	HT070434

USED WITH 2.00 DIAMETER DISTRIBUTOR BORE/CHANNEL	
LENGTH	I.D. = .62 O.D. = 1.62
	ITEM NUMBER
10"	HT150510
18"	HT150518
24"	HT150524
29"	HT150529
34"	HT150534
40"	HT150540
46"	HT150546

NOTES:

Stainless Steel Distributor Tubes available on special order for molding highly corrosive plastics materials.

The Cool One – Thermocouple Distributor Tube Heaters

Obsolete Replacement Parts

Thermocouple (T/C) Distributor Tube Heaters

(240 VAC, T/C type J, 34" leads)



DIA. (AMPS)*	ITEM NUMBER	LENGTH	WATTS
.500 (10 AMP)	HCTC044	4"	380
	HCTC045	5"	500
	HCTC046	6"	600
	HCTC047	7"	700
	HCTC048	8"	820
	HCTC049	9"	920
	HCTC0410	10"	1030
	HCTC0411	11"	1140
	HCTC0412	12"	1250
	HCTC0413	13"	1350
	HCTC0414	14"	1460
	HCTC0415	15"	1570
	HCTC0416	16"	1680
	HCTC0417	17"	1780
	HCTC0418	18"	1900
	HCTC0419	19"	2010
	HCTC0420	20"	2110
	HCTC0421	21"	2220
	HCTC0422	22"	2330
	HCTC0423	23"	2400
.625 (10 AMP)	HCTC0424	24"	2400
	HCTC0425	25"	2400
	HCTC0426	26"	2400
	HCTC0427	27"	2400
	HCTC0428	28"	2400
	HCTC0429	29"	2400
	HCTC0430	30"	2400
	HCTC055	5"	620
HCTC056	6"	750	
HCTC057	7"	880	
HCTC058	8"	1020	
HCTC059	9"	1160	
HCTC0510	10"	1300	

DIA. (AMPS)*	ITEM NUMBER	LENGTH	WATTS
.625 (10 AMP)	HCTC0511	11"	1430
	HCTC0512	12"	1570
	HCTC0513	13"	1700
	HCTC0514	14"	1840
	HCTC0515	15"	1980
	HCTC0516	16"	2110
	HCTC0517	17"	2250
	HCTC0518	18"	2390
	HCTC0519	19"	2520
	HCTC0520	20"	2660
.625 (15 AMP)	HCTC0521	21"	2800
	HCTC0522	22"	2930
	HCTC0523	23"	3070
	HCTC0524	24"	3200
	HCTC0525	25"	3340
	HCTC0526	26"	3480
	HCTC0527	27"	3620
	HCTC0528	28"	3750
	HCTC0529	29"	3900
	HCTC0530	30"	4020
.625 (30 AMP)	HCTC0531	31"	4160
	HCTC0532	32"	4300
	HCTC0534	34"	4570
	HCTC0535	35"	4710
	HCTC0536	36"	4840
	HCTC0537	37"	4980
	HCTC0538	38"	5120
	HCTC0539	39"	5250
	HCTC0540	40"	5390
	HCTC0541	41"	5520
	HCTC0542	42"	5520
	HCTC0543	43"	5520
	HCTC0544	44"	5520

*(AMPS) Amperage requirement for temperature control module.

NOTE: Heaters should be at least 2" shorter than distributor tube length in mold design.

The Cool One – Components

Obsolete Replacement Parts

Auto-Fixed™ “Integral Heater” Probes (240 VAC, T/C Type J Grounded, 48" Leads)

MATERIAL: AISI D-2 STEEL HARDNESS: 50-55 HRC

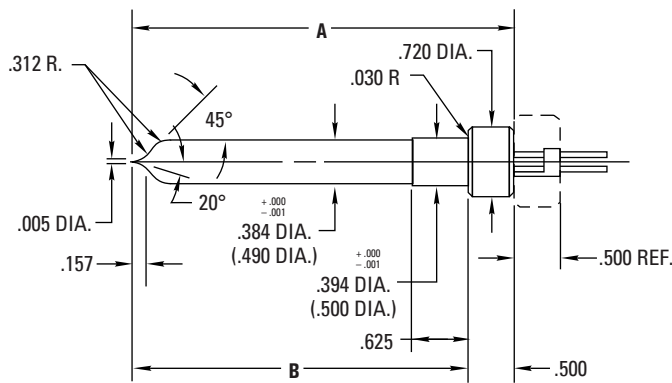

AVAILABLE WITH STRAIGHT OR 90° EXIT HEATER LEADS

NOTE: Probes are special order only



These probes feature a swaged in heating element which is an integral part of the probe. A separate replaceable thermocouple is installed in each probe as supplied. The integral heater design provides highly efficient heat transfer, uniform heat distribution and is guaranteed for one year.

Important: Dimensions shown in parentheses apply to larger probes AFIP5372 thru 622 only. Tolerances shown also apply to dimensions in parentheses.

ITEM NUMBER**		AFIP4 SERIES PROBES .394 (10 mm) DIAMETER		
STRAIGHT EXIT LEADS	90° EXIT LEADS	A DIM.	B DIM.	WATTS
AFIP4322	AFIP432290	3.220	2.720	135
AFIP4372	AFIP437290	3.720	3.220	160
AFIP4422	AFIP442290	4.220	3.720	185
AFIP4472	AFIP447290	4.720	4.220	210

**Includes probe, integral heater, thermocouple, adjustment ring and hold down nut.

ITEM NUMBER**		AFIP5 SERIES PROBES .500 (12.9 mm) DIAMETER		
STRAIGHT EXIT LEADS	90° EXIT LEADS	A DIM.	B DIM.	WATTS
AFIP5372	AFIP537290	3.720	3.220	200
AFIP5422	AFIP542290	4.220	3.720	230
AFIP5472	AFIP547290	4.720	4.220	265
AFIP5522	AFIP552290	5.220	4.720	295
AFIP5572	AFIP557290	5.720	5.220	325
AFIP5622	AFIP562290	6.220	5.720	360

Replacement Thermocouples

(ALL PROBES)

ITEM NUMBER	LEAD LENGTH
TC9900	48"

Gate Inserts

MATERIAL: AISI S-7 STEEL (pre-hardened)

HARDNESS: 30-34 HRC

Hardness can be increased to a higher value by heat treatment, if desired.

ITEM NUMBER	O.D.	I.D.	USED WITH
AFGI04N	1.625	.875	AFIP4 SERIES
AFGI110N	1.750	1.000	AFIP5 SERIES

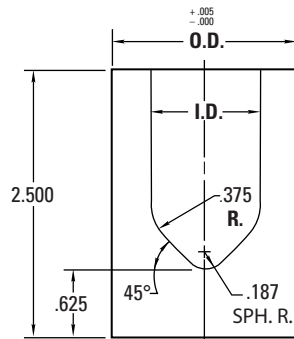

Adjustment Rings

(Packaged with all probes)

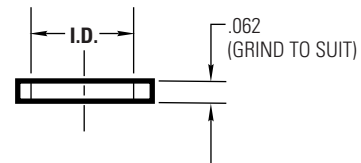

ITEM NUMBER†	I.D.	USED WITH
RAF4062	.469	AFIP4 SERIES
RAF5062	.565	AFIP5 SERIES

†Bag of 5 rings.

Register Rings

MATERIAL: AISI H-13 STEEL

HARDNESS: 48-52 HRC

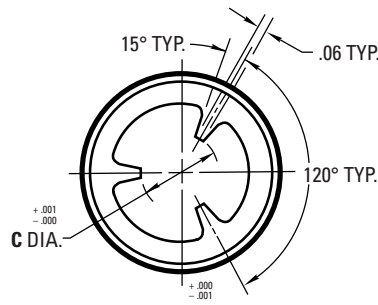
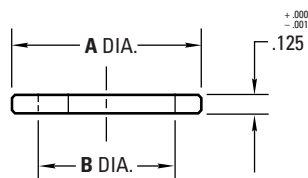

ITEM NUMBER	A DIM.	B DIM.	C DIM.	USED WITH
AFRR04N	1.062	.865	.387	AFIP4 SERIES
AFRR05N	1.187	.937	.493	AFIP5 SERIES

Hold-Down Nut

(Packaged with all probes)

THICKNESS = .500

THREAD = 1" - 8

HEX FLAT = 3/16

ITEM NUMBER
AFN100



Hold-Down Nut Wrench*

ITEM NUMBER
WR916

*Required for straight exit leads only.

The Cool One – Probes and Probe Heaters

Auto-Fixed™ Probes (3" to 6" long)

MATERIAL: AISI D-2 STEEL
HARDNESS: 50-55 HRC

Obsolete Replacement Parts

LENGTH A	ITEM NUMBER **
2.893	AFP310
3.625	AFP410
4.625	AFP510
5.609	AFP610

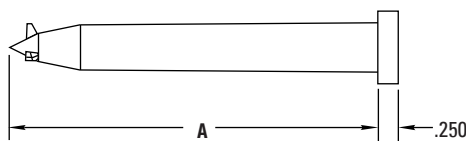

**Includes probe, stop sleeve and hold down nut only.

These finned style Auto-Fixed probes employ a precision engineered tip configuration that automatically “fixes” the relationship between probe tip and gate, centering the probe and limiting tip protrusion into the gate. Thermocouple heaters are guaranteed for one year as detailed under the

heater chart below. Gate inserts (shown on next page), pre-machined for use with these probes, can save valuable machining time and help assure optimum probe performance.

Auto-Fixed™ Finless Probes (3" to 6" long)

MATERIAL: AISI D-2 STEEL
HARDNESS: 50-55 HRC

LENGTH A	ITEM NUMBER **
2.893	AFPN310
3.625	AFPN410
4.625	AFPN510
5.609	AFPN610

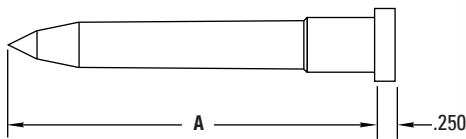

**Includes probe, stop sleeve and hold down nut only.

These finless style Auto-Fixed probes are available in the same sizes as the finned probes above and also in lengths up to 10". An optional register ring is available to provide added stability at the probe tip if desired. As with the finned probes, thermocouple heaters are guaranteed for one year and pre-machined gate inserts are available.

NOTE: Due to minimum distance requirements specified, the AFPO310 and AFPN310 probes cannot be used in a Cool One system. They may, however, be used in an insulated runner system.

Thermocouple (T/C) Probe Heaters†

(.246 diameter, 240 VAC, T/C type J grounded, 34" leads)



ITEM NUMBER	FOR PROBE	WATTS	LENGTH
AFTC2132	AFP(N)310	150	3.00
AFTC2142	AFP(N)410	220	3.75
AFTC2152	AFP(N)510	275	4.75
AFTC2162	AFP(N)610	350	5.75

Non-Thermocouple Probe Heaters

(.246 diameter, 240 VAC, 34" leads)



ITEM NUMBER	FOR PROBE	WATTS	LENGTH
AFC2132	AFP(N)310	150	3.00
AFC2142	AFP(N)410	220	3.75
AFC2152	AFP(N)510	275	4.75
AFC2162	AFP(N)610	350	5.75

†Thermocouple (T/C) Probe Heaters are guaranteed for one year from date of shipment.

The Cool One – Accessories and Replacement Parts

[Obsolete Replacement Parts](#)

Accessories/Replacement Parts for 3" to 6" Long Auto-fixed Probes

See design and machining guidelines at the end of this Internally Heated Hot Runner Systems section.

Hold-Down Nut

(Packaged with all probes)

Thickness = .50
Thread = 1"-8
Hex Flat = $\frac{9}{16}$



ITEM NUMBER

AFN100

Stop Sleeve

(Packaged with all probes)

Length = 1.375
Thread = $\frac{3}{8}$ "-24
Dia. = .375



ITEM NUMBER

AFSS38

Register Ring

(For Finless Probes Only)

AISI H-13 STEEL
48-52 HRC
I.D. = .562
O.D. = 1.375
Thickness = .125



ITEM NUMBER

AFRR10N

Gate Inserts

MATERIAL: AISI S-7 STEEL (pre-hardened)

HARDNESS: 30-34 HRC

Hardness can be increased to a higher value by heat treatment, if desired.

I.D. = 1.000 O.D. = 1.750 Height = 2.500



ITEM NUMBER

AFGI10

FOR PROBE

AFP310 thru 610

AFGI10N

AFPN310 thru 610

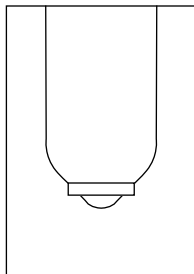

AFGI10

Gate inserts are supplied premachined. See design and machining guidelines at the end of this Internally Heated Hot Runner Systems section.

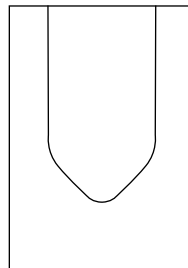

AFGI10N

Adjustment Rings

For simplified counterbore depth adjustment (No change from previous rings).

I.D. = .687 O.D. = .868



ITEM NUMBER*

THICKNESS

RAF002	.002
RAF003	.003
RAF005	.005
RAF007	.007
RAF032	.032
RAF062	.062
RAF125	.125

*Package of 10.

Replacement Thermocouple (T/C) And Non T/C Heaters

FOR DISCONTINUED AUTO-FIXED PROBES AFP300, 400, 500, 600
(.250 diameter, 240 VAC, T/C type J grounded, 36" leads)

While the original Auto-Fixed probes (AFP300, 400, 500, 600) have been replaced with the AFP310 thru 610 series, replacement heaters for these previous probes are still available as detailed here.

T/C HEATERS ITEM NUMBER	NON T/C HEATERS ITEM NUMBER	FOR PROBE	WATTS	LENGTH
AFTC2022	AFC2022	AFP300	200	2"
AFTC2032	AFC2032	AFP400	300	3"
AFTC2042	AFC2042	AFP500	375	4"
AFTC2052	AFC2052	AFP600	475	5"

The Cool One – Accessories and Replacement Parts

Obsolete Replacement Parts

Auto-Fixed™ Finless Probes (7" to 10" long)

MATERIAL: AISI D-2 STEEL
HARDNESS: 50-55 HRC

These longer probes are ideal for larger molds or gating into deeper cavity configurations. The optional register ring shown below may be used to provide added stability at the probe tip if desired. Thermocouple heaters are guaranteed for one year as detailed under the heater chart below.

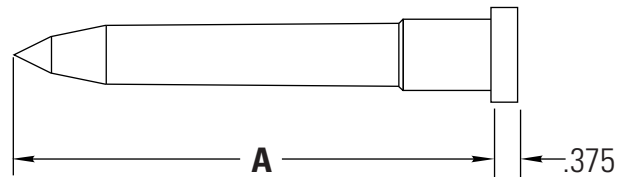

LENGTH A	ITEM NUMBER**
7.000	AFPN720
8.000	AFPN820
9.000	AFPN920
10.000	AFPN1020

**Includes probe, stop sleeve and hold down nut only.

Hold-Down Nut

(Packaged with all probes)

Thickness = .50
Thread = 1/4"-12
Hex Flat = 5/8



ITEM NUMBER

AFN125

Stop Sleeve

(Packaged with all probes)

Length = 1.375
Thread = 1/2"-20
Dia. = .500



ITEM NUMBER

AFSS12

Register Ring

AISI H-13 STEEL
48-52 HRC
I.D. = .693
O.D. = 1.500



ITEM NUMBER

AFRR20N

Thermocouple (T/C) Probe Heaters[†]

(.375 diameter, 240 VAC, T/C type J grounded, 46" leads)



ITEM NUMBER	FOR PROBE	WATTS	LENGTH
AFTC3272	AFPN720	645	7.15
AFTC3282	AFPN820	760	8.15
AFTC3292	AFPN920	870	9.15
AFTC32102	AFPN1020	980	10.15

[†]Thermocouple (T/C) Probe Heaters are guaranteed for one year from date of shipment.

Gate Insert

MATERIAL: AISI S-7 STEEL (pre-hardened)
HARDNESS: 30-34 HRC

Hardness can be increased to a higher value by heat treatment, if desired.

I.D. = 1.125 O.D. = 2000 Height = 2.500

ITEM NUMBER

AFGI20N



Adjustment Rings

Moldmaker to supply to suit (.990 O.D., .820 I.D.)

Modular Components Deliver High-Performance Solutions



Today's increasingly feature-packed plastic products benefit tremendously from the right hot runner solution. Increasing resin costs and the complexity of engineered materials only compound this challenge. From hot sprue bushings to turnkey hot halves, DME offers a wide range of solutions to almost any molding application.

Get the modular advantage with DME hot runner systems

DME's newest family of hot runner systems are built on an architecture of modular components so we can quickly custom configure a system that is ideal for your application. With the tremendous time pressures on moldmakers today, our modular architecture enables industry-leading delivery times. This modular approach shortens delivery, improves cost-effectiveness and optimizes performance. DME's Meteor and Stellar hot runner systems offer standardized products, custom-configured to each application in only a few days.

Our dedicated team of application engineers works to understand the critical variables of your molding equation.

Here are a few areas in which our global capabilities make hot runner solutions more efficient and more economical.

Micromolding solutions

As plastic parts get smaller and more complex, micromolding solutions become more challenging. DME Stellar Hot Runner Systems were designed for the demands of very small part molding with engineered or commodity materials. The Stellar hot runner system is available for applications with center-to-center dimensions as close as 17mm.

Application engineered solutions

As an industry leader in hot runner systems, DME is able to offer our customers a comprehensive resource for hot runner solutions. Our dedicated team of application engineers works to understand the critical variables of your molding equation and engineer a hot runner system solution that is optimal for your project.

Powerful custom manufacturing capabilities

For more complex, custom and even high cavitation applications, DME offers extensive manufacturing capabilities enabling complete, custom solutions. For example, turnkey hot half systems — fully assembled, wired, and electrically tested — are ready to drop in with no machining and minimal installation demands.

DME Service Centers

Ensuring the Productivity of every Hot Runner System

Full-Service Hot Runner Support

Mold technology leader DME - known for servicing its customers every step of the way - provides total support for your hot runner systems. No matter what brand of hot runner, DME will repair, reconfigure or even totally rebuild it to ensure maximum performance of your system.

A Dedicated Center for Hot Runner Systems

Our Service Center, located in Madison Heights, Mich., is exclusively dedicated to supporting your hot runner systems. Staffed by a team of industry experts whose sole focus is hot runner systems, we aim to provide optimal repair and troubleshooting to maintain and get your system operating at maximum efficiency. This group has over three decades of experience installing, assembling, and repairing hot runner systems. And, our dedicated staff will get your system back into your facility quickly and cost-effectively. Please contact us for other service center locations.

Hot Runner Services Overview

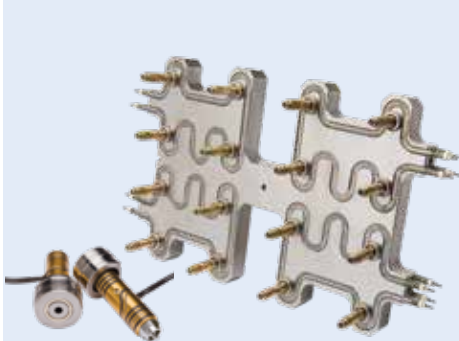

The DME family of hot runner products and services offers a comprehensive array of solutions for a wide range of applications.



Unrivalled Support When and Where You Need It

Since the 1970s, DME has developed and marketed a full spectrum of hot runner systems and components. From Moldflow analysis to turnkey hot half systems and everything in between, the DME family of hot runner products and services offers a comprehensive array of solutions for a wide range of applications. Whether your need is for standard, off-the-shelf components, customer engineered manifolds, or fully assembled systems ready for bolt-on installation, DME has a proven solution to match your application.

Moldflow Services

As the first mold technologies supplier to earn Moldflow's silver certification, DME is highly adept at applying Finite Element Analysis (FEA) techniques to help optimize part and mold design. Whether you need Mold Fill, Mold Pack, Mold Cool or Warp analyses, DME can assist you in maximizing the results of your next application.

Applications Engineering and Technical Service

Our dedicated and experienced team of mold designers, technicians and applications engineers assists DME customers with product selection, system design, performance analysis and technical advice. DME technical service representatives are globally located for complete coverage and quick availability no matter where your hot runner production takes place. Technical experts employed worldwide are available for start-ups, personnel training or system service.

Comprehensive Hot Runner and Aftermarket Service

Staffed by a team whose sole focus is hot runner systems, the DME Hot Runner Service Center offers a single source for hot runner system optimization and maintenance. Our services include expedited repairs, system cleaning, system rebuilds, re-configuration and refurbishment for virtually any type of hot runner system.

DME Service Centers

A Wide Range of Services

We recognize the value of your time - that's why we've developed a comprehensive suite of hot runner services to provide a single source for maintenance and optimization of your system.

Key capabilities and services include:

- System evaluations
- Repairs - systems and components
- System cleaning and rewiring of all hot runner systems - including complete bake-out
- Total system rebuild/reburishment
- Re-configuration
- Operating training
- All machining capabilities
- Processing support

Cost-Effective Reconfiguration

When your process needs change, without a significant tooling change, we can adapt your hot runner to the new process. Whether it's a material switch, or a part design change, DME can help reconfigure your existing system.

Training Maximizes Productivity, Speeds Set-Up

The DME Hot Runner Service Center and technicians can provide comprehensive operator training from start-up to production processing. Our hands-on programs help your operators get up-to-speed, or stay current on hot runner technology.

Preventative Maintenance (PM)

It is important to protect and update your hot runner system to ensure it is running at the highest efficiency. The PM Program is designed to provide life cycle management of your systems and enhance equipment reliability by:

- Replacing worn components before they fail
- Maximizes system performance
- Reduces cost of replacement
- Ensures peak part quality
- Decreases system downtime
- Protects your investment

The PM Program can be set up either by system cycles or by scheduled PM

Rebuilds Ensure Performance

After tens of thousands of cycles you may have noticed your system just doesn't perform the way it used to. Or maybe you've run high-temperature engineered materials and the tolerances just aren't as tight. Key benefits of system rebuilds include:

- Cost savings of at least 40% as compared to new systems
- Extended life for your tool
- Maximizing system uptime and performance

Whether you need a total system rebuild, or a simple cleaning and inspection DME can help. System rebuilds can be performed on any brand of hot runner system and typically include:

- Complete bake-out cleaning
- Check and replace heaters and thermocouples
- Inspect and correct wiring
- Replace seals, bushings and other wear items
- Clean or replace nozzle components
- Check and validate all dimensions before re-assembling the system

Repairs Get You Back Up Quickly

Time is money. When a critical tool is out of commission, productivity is lost and production schedules can be threatened. We understand this at DME. That's why our team of hot runner technical specialists are always available to get you back in service.

Whether you're experiencing leaks, heating issues, flow problems, or would simply like a system bake-out, we'll repair your system quickly and cost-effectively.

Standard turnaround for repairs on systems from 1-12 drops (depending on parts availability for non-DME systems) is 5 working days or less. If your system has over 12 drops, contact us for an estimated turnaround time. And, we offer emergency 24-hour service.

Mold Tryouts

Our Technical specialists can also support your mold tryouts to optimize hot runner performance.

DME Obsolete Replacement Parts

REPLACEMENT PARTS FOR OBSOLETE
HOT RUNNER SYSTEMS & NOZZLES



Mini Gate-Mate® Nozzles

NOZZLE SUB-ASSEMBLY (ORDER TIP SEPARATELY)		INCLUDES				
		1	2		3	4
ITEM NUMBER	HEATER TYPE	NOZZLE BODY	HEATER	WATTS	THERMO-COUPLE	SEAL RING
GMB0110	CAST-IN	GMB0105	CIH0100	250	N/A (INTEGRAL)	EHR7155
GMB0118	SQUARE COIL	GMB0105	SCH0004	250	TCG0100	

1/2" SPH. RADIUS BUSHING SUB-ASSEMBLY		FLAT BUSHING SUB-ASSEMBLY	
ITEM NUMBER	HEATER TYPE	ITEM NUMBER	HEATER TYPE
GMB0116	SQUARE COIL	GMB0117	SQUARE COIL
GMB0111	CAST-IN	GMB0112	CAST-IN

Mini Gate-Mate® Tips

Contact DME for tip recommendations and assistance with your application.

ITEM NUMBER	TIP STYLE
GMT0100	STANDARD
GMT4101	WEAR RESISTANT

Mini Gate-Mate Bushing Locating Ring

ITEM NUMBER
6548

Gate-Mate® 4 Nozzles and Tips

[Obsolete Replacement Parts](#)

A	NOZZLE ASSEMBLY (INCLUDES GMT2 TIP)	NOZZLE SUB ASSEMBLY (TIP ORDERED SEPARATELY)	INCLUDES				
			1	2		3	4
			NOZZLE BODY	SQUARE COIL HEATER	WATTS	THERMO-COUPLE	SEAL RING
2.000	GMB0050	GMB0150	GMB0060	SCH0060	250	TCG0060	EHR7155
2.500	GMB0051	GMB0151	GMB0061	SCH0061	300	TCG0061	
3.000	GMB0052	GMB0152	GMB0062	SCH0062	350	TCG0062	
3.500	GMB0053	GMB0153	GMB0063	SCH0063	400	TCG0063	
4.000	GMB0054	GMB0154	GMB0064	SCH0064	425	TCG0064	
5.000	GMB0055	GMB0155	GMB0065	SCH0065	500	TCG0065	
6.000	GMB0056	GMB0156	GMB0066	SCH0066	500	TCG0066	

NOTES:

- Items 1 thru 4 are available separately for replacement purposes
- Items 2 is 240 VAC, 36" leads, 34" fiberglass lead protection
- Item 3 is type J, with 36" leads, 34" fiberglass lead protection
- Item 4 (for replacement) is sold in packs of 4 only

INCLUDES			
1	2		3
NOZZLE BODY	FRONT LOAD HEATER	WATTS	SEAL RING
GMB0060	SCH1060	250	EHR7155
GMB0061	SCH1061	300	
	SCH2061		
GMB0062	SCH1062	350	
	SCH2062		
GMB0063	SCH1063	400	
	SCH2063		
GMB0064	SCH1064	425	
	SCH2064		
GMB0065	SCH1065	500	
	SCH2065		
GMB0066	SCH1066	500	
	SCH2066		

NOTES:

- Items 1, 2 and 3 are available separately for replacement purposes
- Item 2 is 240 VAC, type J thermocouple, 36" leads, 34" Teflon lead protection
- Item 3 (for replacement) is sold in packs of 4 only

Replacement Seal Rings

ITEM NUMBER
EHR7155

Gate-Mate® 4 Tips

TIP STYLE	TIP ITEM NUMBER	O DIA.	TIP LENGTH	TIP DIA.	HOLE DIA.
STANDARD	GMT2	.044 MIN.		.024	
WEAR RESISTANT	GMT0400	.055 MIN.			
SUPER SHARP	GMT0301	.030 MIN.	1.730	.010	N/A
SUPER SHARP WEAR RESISTANT	GMT0401	.055 MIN.			
THRU HOLE	GMT0302*	.030 MIN. .050 MAX	1.690	.090	.050
THRU HOLE WEAR RESISTANT	GMT0402*	.055 MIN.			
NO HOLE	GMT0303	.044 MIN.	1.730	.024	N/A

NOTES:

- Thru hole tip is designed .040 shorter in length to be a direct replacement for the standard tip; use a .030 to .060 diameter gate
- A .030 minimum diameter gate is recommended when using the super sharp tip
- Contact DME for tip recommendations and assistance with your application

*Contact DME for details to modify thru hole tips for larger "O" diameters

Gate Shell Insulators

Gate Shell Insulators

- Improves insulation in the tip area
- Provides seal-off to eliminate material degradation in threaded area of tip
- Minimizes material in gate area to allow for faster color changes
- Withstands temperatures up to 550° F



Typical Application

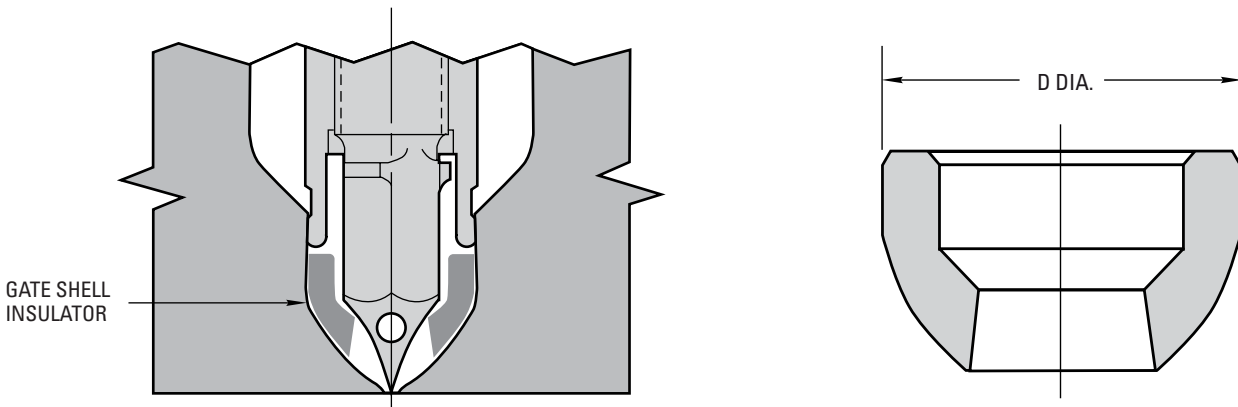

FOR BUSHING OR NOZZLE STYLE	FOR TIP STYLE	ITEM NUMBER
Gate-Mate 4 Nozzle	Standard, Super Sharp, No Hole	GSI0001
	Thru Hole	GSI0002
Jumbo Gate-Mate Bushing or Nozzle	Standard	GSI0003
	Thru Hole	GSI0004
Medium Gate-Mate Bushing	Standard, Super Sharp, No Hole	GSI0005
	Thru Hole	GSI0006

D DIA.	ITEM NUMBER
.748	GSI0001
	GSI0002
1.248	GSI0003
	GSI0004
.748	GSI0005
	GSI0006

APPLICATION NOTES:

1. Use only with bushings, nozzles and tip styles shown in the reference chart above
2. Gate machining must be done according to DME specifications
3. Nozzle tip cannot be altered in any way for the Gate Shell Insulator to perform properly
4. If dissimilar resins are to be processed in the same mold, it is recommended that their processing temperatures be within a similar range
5. For best results, the outer surface of the tip should be free from all resin before the Gate Shell Insulator is installed or used

Components for Micro Cool One® Split Plate/Solid Block Designs

Obsolete Replacement Parts

Thermocouple (T/C) Distributor Tube Heaters (240 VAC, T/C Type J, 34" Leads)

Distributed wattage heater design for more uniform temperature control. Sealed, flexible teflon covered leads to prevent lead damage and improve moisture resistance.

DIA (AMPS)*	ITEM NUMBER	OVERALL LENGTH	HEATED LENGTH	WATTS	DIA (AMPS)*	ITEM NUMBER	OVERALL LENGTH	HEATED LENGTH	WATTS
.375 (10 AMP)	HCTC034	5.000	4.000	320	.375 (10 AMP)	HCTC0375	8.500	7.500	515
	HCTC0345	5.500	4.500	340		HCTC038	9.000	8.000	550
	HCTC035	6.000	5.000	400		HCTC039	10.000	9.000	650
	HCTC0355	6.500	5.500	430		HCTC0310	11.000	10.000	710
	HCTC036	7.000	6.000	450		HCTC0311	12.000	11.000	720
	HCTC0365	7.500	6.500	470		HCTC0312	13.000	12.000	760
	HCTC037	8.000	7.000	480		HCTC0313	14.000	13.000	810

*(AMPS) = Amperage requirement for temp. control module.

Distributor Tubes

MATERIAL: AISI 4140 STEEL

HARDNESS: 28-35 HRC

ITEM NUMBER	LENGTH
HT050312	11.82
HT050316	15.76

End Cap

MATERIAL: AISI 4140 STEEL

ITEM NUMBER
EC1105

Components for Micro Cool One® Solid Block Designs

Auto-fixed® "Integral Heater" Micro Probes (240 VAC, T/C Type J, 48" Leads)

MATERIAL: AISI D-2 STEEL

HARDNESS: 50-55 HRC

ITEM NUMBER*	A	B	WATTS
AFIP331090	3.095	2.720	110
AFIP336090	3.595	3.220	130
AFIP341090	4.095	3.720	150
AFIP346090	4.595	4.220	170



NOTE: Probes are special order only

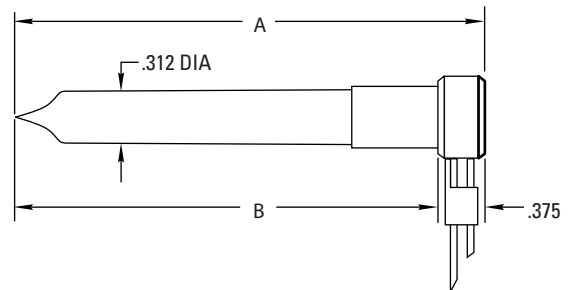

Replacement Thermocouple

ITEM NUMBER	LEAD LENGTH
TC9900	48"

Register Ring

MATERIAL: AISI H-13 STEEL

HARDNESS: 48-52 HRC

I.D. = .313

O.D. = 1.000

ITEM NUMBER*
RAF3062

*Package of 10.



The Cool One – Heated Nozzle Locator Replacement Parts

Heated Nozzle Locator Assemblies

HNL462 and HNL662 assemblies include:

- HNC46 or HNC66 core, respectively
- SSTC6290 heater
- HNS67 spacer

R	ITEM NUMBER
1/2	HNL462
	HNL472
3/4	HNL662
	HNL672

[Obsolete Replacement Parts](#)

HNL472 and HNL672 assemblies include:

- HNC47 or HNC67 core, respectively
- SSTC7290 heater
- HNS67 spacer

Cores

R	ITEM NUMBER
1/2	HNC46
	HNC47
3/4	HNC66
	HNC67



Thermocouple Heaters

(240 VAC, 250 WATTS T/C type J 36" leads)

ITEM NUMBER	USED WITH CORES
SSTC6290	HNC46 & 66
SSTC7290	HNC47 & 67



Spacer

ITEM NUMBER
HNS67



ITEM NUMBER	R
NL6702	1/2
NL6703	3/4



The Cool One – End Caps and Distributor Tubes

End Caps (for use with solid distributor block designs)

Obsolete Replacement Parts

MATERIAL: AISI 4140 STEEL

End caps provide concentricity between distributor tube and distributor bore. Thread accommodates heater stop or lead wire protector.

END CAPS FOR SPLIT PLATE DESIGNS: Moldmaker to supply to suit.

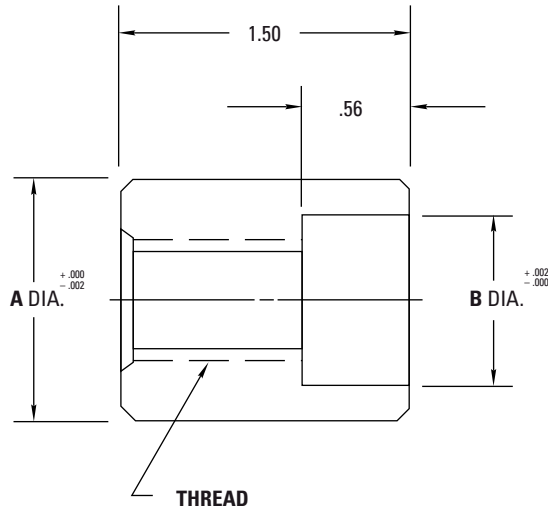

ITEM NUMBER	DIA. A	DIA. B	THREAD	USED WITH DIST. BORE/TUBE
EC1207	1.249	0.875	5/8" - 11	1.25 DIA./ .87 O.D.
EC2015	1.999	1.625	3/4" - 10	2.00 DIA./1.62 O.D.

Distributor Tubes

MATERIAL: AISI P-20 STEEL

HARDNESS: 28-35 HRC

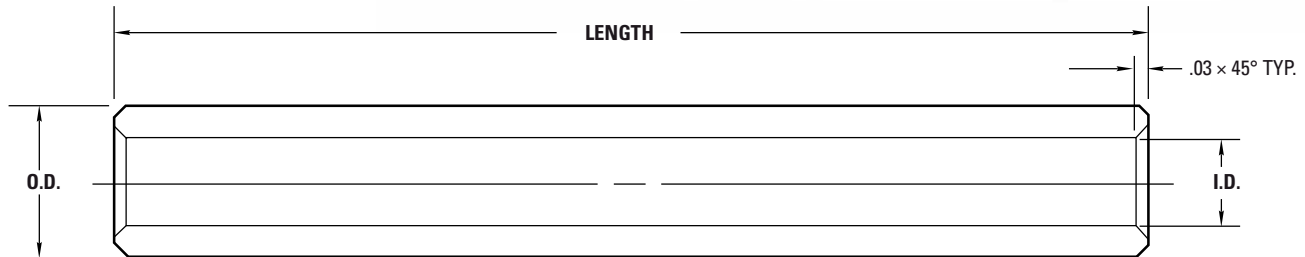

USED WITH 1.25 DIAMETER DISTRIBUTOR BORE/CHANNEL	
LENGTH	I.D. = .50 O.D. = .87
	ITEM NUMBER
6"	HT07046
10"	HT070410
16"	HT070416
20"	HT070420
24"	HT070424
29"	HT070429
34"	HT070434

USED WITH 2.00 DIAMETER DISTRIBUTOR BORE/CHANNEL	
LENGTH	I.D. = .62 O.D. = 1.62
	ITEM NUMBER
10"	HT150510
18"	HT150518
24"	HT150524
29"	HT150529
34"	HT150534
40"	HT150540
46"	HT150546

NOTES:

Stainless Steel Distributor Tubes available on special order for molding highly corrosive plastics materials.

The Cool One – Thermocouple Distributor Tube Heaters

Obsolete Replacement Parts

Thermocouple (T/C) Distributor Tube Heaters

(240 VAC, T/C type J, 34" leads)



DIA. (AMPS)*	ITEM NUMBER	LENGTH	WATTS
.500 (10 AMP)	HCTC044	4"	380
	HCTC045	5"	500
	HCTC046	6"	600
	HCTC047	7"	700
	HCTC048	8"	820
	HCTC049	9"	920
	HCTC0410	10"	1030
	HCTC0411	11"	1140
	HCTC0412	12"	1250
	HCTC0413	13"	1350
	HCTC0414	14"	1460
	HCTC0415	15"	1570
	HCTC0416	16"	1680
	HCTC0417	17"	1780
	HCTC0418	18"	1900
	HCTC0419	19"	2010
	HCTC0420	20"	2110
	HCTC0421	21"	2220
	HCTC0422	22"	2330
	HCTC0423	23"	2400
.625 (10 AMP)	HCTC0424	24"	2400
	HCTC0425	25"	2400
	HCTC0426	26"	2400
	HCTC0427	27"	2400
	HCTC0428	28"	2400
	HCTC0429	29"	2400
	HCTC0430	30"	2400
	HCTC055	5"	620
HCTC056	6"	750	
HCTC057	7"	880	
HCTC058	8"	1020	
HCTC059	9"	1160	
HCTC0510	10"	1300	

DIA. (AMPS)*	ITEM NUMBER	LENGTH	WATTS
.625 (10 AMP)	HCTC0511	11"	1430
	HCTC0512	12"	1570
	HCTC0513	13"	1700
	HCTC0514	14"	1840
	HCTC0515	15"	1980
	HCTC0516	16"	2110
	HCTC0517	17"	2250
	HCTC0518	18"	2390
	HCTC0519	19"	2520
	HCTC0520	20"	2660
.625 (15 AMP)	HCTC0521	21"	2800
	HCTC0522	22"	2930
	HCTC0523	23"	3070
	HCTC0524	24"	3200
	HCTC0525	25"	3340
	HCTC0526	26"	3480
	HCTC0527	27"	3620
	HCTC0528	28"	3750
	HCTC0529	29"	3900
	HCTC0530	30"	4020
.625 (30 AMP)	HCTC0531	31"	4160
	HCTC0532	32"	4300
	HCTC0534	34"	4570
	HCTC0535	35"	4710
	HCTC0536	36"	4840
	HCTC0537	37"	4980
	HCTC0538	38"	5120
	HCTC0539	39"	5250
	HCTC0540	40"	5390
	HCTC0541	41"	5520
	HCTC0542	42"	5520
	HCTC0543	43"	5520
	HCTC0544	44"	5520

*(AMPS) Amperage requirement for temperature control module.

NOTE: Heaters should be at least 2" shorter than distributor tube length in mold design.

The Cool One – Components

Obsolete Replacement Parts

Auto-Fixed™ “Integral Heater” Probes (240 VAC, T/C Type J Grounded, 48" Leads)

MATERIAL: AISI D-2 STEEL HARDNESS: 50-55 HRC

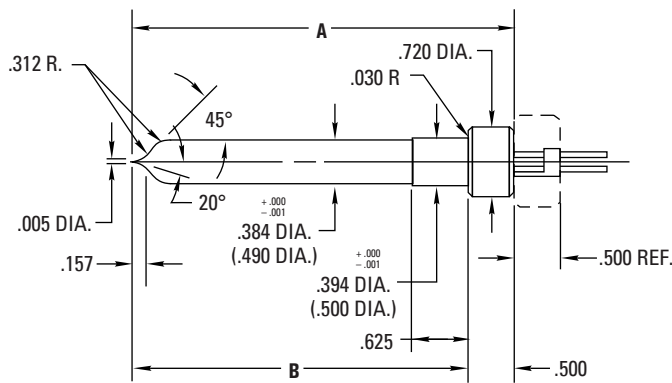

AVAILABLE WITH STRAIGHT OR 90° EXIT HEATER LEADS

NOTE: Probes are special order only



These probes feature a swaged in heating element which is an integral part of the probe. A separate replaceable thermocouple is installed in each probe as supplied. The integral heater design provides highly efficient heat transfer, uniform heat distribution and is guaranteed for one year.

Important: Dimensions shown in parentheses apply to larger probes AFIP5372 thru 622 only. Tolerances shown also apply to dimensions in parentheses.

ITEM NUMBER**		AFIP4 SERIES PROBES .394 (10 mm) DIAMETER		
STRAIGHT EXIT LEADS	90° EXIT LEADS	A DIM.	B DIM.	WATTS
AFIP4322	AFIP432290	3.220	2.720	135
AFIP4372	AFIP437290	3.720	3.220	160
AFIP4422	AFIP442290	4.220	3.720	185
AFIP4472	AFIP447290	4.720	4.220	210

**Includes probe, integral heater, thermocouple, adjustment ring and hold down nut.

ITEM NUMBER**		AFIP5 SERIES PROBES .500 (12.9 mm) DIAMETER		
STRAIGHT EXIT LEADS	90° EXIT LEADS	A DIM.	B DIM.	WATTS
AFIP5372	AFIP537290	3.720	3.220	200
AFIP5422	AFIP542290	4.220	3.720	230
AFIP5472	AFIP547290	4.720	4.220	265
AFIP5522	AFIP552290	5.220	4.720	295
AFIP5572	AFIP557290	5.720	5.220	325
AFIP5622	AFIP562290	6.220	5.720	360

Replacement Thermocouples

(ALL PROBES)

ITEM NUMBER	LEAD LENGTH
TC9900	48"

Gate Inserts

MATERIAL: AISI S-7 STEEL (pre-hardened)

HARDNESS: 30-34 HRC

Hardness can be increased to a higher value by heat treatment, if desired.

ITEM NUMBER	O.D.	I.D.	USED WITH
AFGI04N	1.625	.875	AFIP4 SERIES
AFGI110N	1.750	1.000	AFIP5 SERIES

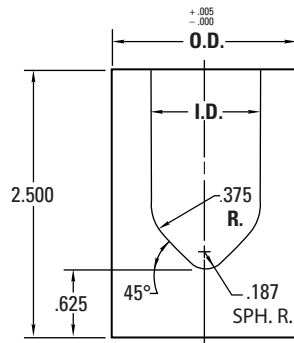

Adjustment Rings

(Packaged with all probes)

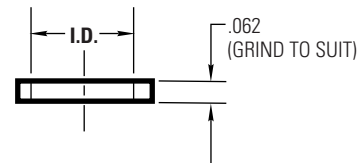

ITEM NUMBER†	I.D.	USED WITH
RAF4062	.469	AFIP4 SERIES
RAF5062	.565	AFIP5 SERIES

†Bag of 5 rings.

Register Rings

MATERIAL: AISI H-13 STEEL

HARDNESS: 48-52 HRC

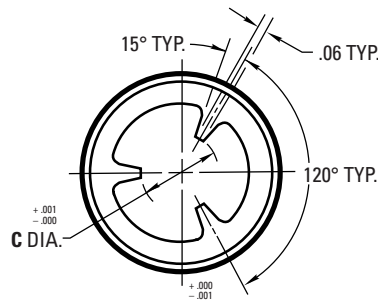
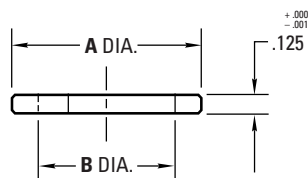

ITEM NUMBER	A DIM.	B DIM.	C DIM.	USED WITH
AFRR04N	1.062	.865	.387	AFIP4 SERIES
AFRR05N	1.187	.937	.493	AFIP5 SERIES

Hold-Down Nut

(Packaged with all probes)

THICKNESS = .500

THREAD = 1" - 8

HEX FLAT = 3/16

ITEM NUMBER
AFN100



Hold-Down Nut Wrench*

ITEM NUMBER
WR916

*Required for straight exit leads only.

The Cool One – Probes and Probe Heaters

Auto-Fixed™ Probes (3" to 6" long)

MATERIAL: AISI D-2 STEEL
HARDNESS: 50-55 HRC

Obsolete Replacement Parts

LENGTH A	ITEM NUMBER **
2.893	AFP310
3.625	AFP410
4.625	AFP510
5.609	AFP610

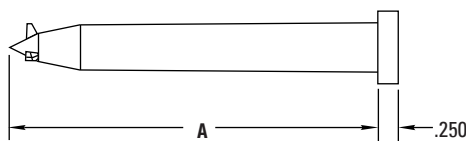

**Includes probe, stop sleeve and hold down nut only.

These finned style Auto-Fixed probes employ a precision engineered tip configuration that automatically “fixes” the relationship between probe tip and gate, centering the probe and limiting tip protrusion into the gate. Thermocouple heaters are guaranteed for one year as detailed under the

heater chart below. Gate inserts (shown on next page), pre-machined for use with these probes, can save valuable machining time and help assure optimum probe performance.

Auto-Fixed™ Finless Probes (3" to 6" long)

MATERIAL: AISI D-2 STEEL
HARDNESS: 50-55 HRC

LENGTH A	ITEM NUMBER **
2.893	AFPN310
3.625	AFPN410
4.625	AFPN510
5.609	AFPN610

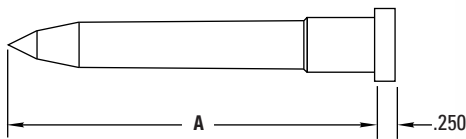

**Includes probe, stop sleeve and hold down nut only.

These finless style Auto-Fixed probes are available in the same sizes as the finned probes above and also in lengths up to 10". An optional register ring is available to provide added stability at the probe tip if desired. As with the finned probes, thermocouple heaters are guaranteed for one year and pre-machined gate inserts are available.

NOTE: Due to minimum distance requirements specified, the AFPO310 and AFPN310 probes cannot be used in a Cool One system. They may, however, be used in an insulated runner system.

Thermocouple (T/C) Probe Heaters†

(.246 diameter, 240 VAC, T/C type J grounded, 34" leads)



ITEM NUMBER	FOR PROBE	WATTS	LENGTH
AFTC2132	AFP(N)310	150	3.00
AFTC2142	AFP(N)410	220	3.75
AFTC2152	AFP(N)510	275	4.75
AFTC2162	AFP(N)610	350	5.75

Non-Thermocouple Probe Heaters

(.246 diameter, 240 VAC, 34" leads)



ITEM NUMBER	FOR PROBE	WATTS	LENGTH
AFC2132	AFP(N)310	150	3.00
AFC2142	AFP(N)410	220	3.75
AFC2152	AFP(N)510	275	4.75
AFC2162	AFP(N)610	350	5.75

†Thermocouple (T/C) Probe Heaters are guaranteed for one year from date of shipment.

The Cool One – Accessories and Replacement Parts

[Obsolete Replacement Parts](#)

Accessories/Replacement Parts for 3" to 6" Long Auto-fixed Probes

See design and machining guidelines at the end of this Internally Heated Hot Runner Systems section.

Hold-Down Nut

(Packaged with all probes)

Thickness = .50
Thread = 1"-8
Hex Flat = $\frac{9}{16}$



ITEM NUMBER

AFN100

Stop Sleeve

(Packaged with all probes)

Length = 1.375
Thread = $\frac{3}{8}$ "-24
Dia. = .375



ITEM NUMBER

AFSS38

Register Ring

(For Finless Probes Only)

AISI H-13 STEEL
48-52 HRC
I.D. = .562
O.D. = 1.375
Thickness = .125



ITEM NUMBER

AFRR10N

Gate Inserts

MATERIAL: AISI S-7 STEEL (pre-hardened)

HARDNESS: 30-34 HRC

Hardness can be increased to a higher value by heat treatment, if desired.

I.D. = 1.000 O.D. = 1.750 Height = 2.500



ITEM NUMBER

AFGI10

FOR PROBE

AFP310 thru 610

AFGI10N

AFPN310 thru 610

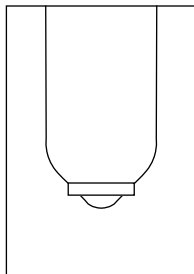

AFGI10

Gate inserts are supplied premachined. See design and machining guidelines at the end of this Internally Heated Hot Runner Systems section.

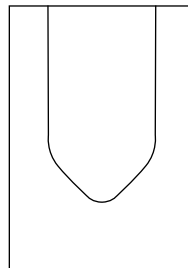

AFGI10N

Adjustment Rings

For simplified counterbore depth adjustment (No change from previous rings).

I.D. = .687 O.D. = .868



ITEM NUMBER*

THICKNESS

RAF002

.002

RAF003

.003

RAF005

.005

RAF007

.007

RAF032

.032

RAF062

.062

RAF125

.125

*Package of 10.

Replacement Thermocouple (T/C) And Non T/C Heaters

FOR DISCONTINUED AUTO-FIXED PROBES AFP300, 400, 500, 600
(.250 diameter, 240 VAC, T/C type J grounded, 36" leads)

While the original Auto-Fixed probes (AFP300, 400, 500, 600) have been replaced with the AFP310 thru 610 series, replacement heaters for these previous probes are still available as detailed here.

T/C HEATERS ITEM NUMBER	NON T/C HEATERS ITEM NUMBER	FOR PROBE	WATTS	LENGTH
AFTC2022	AFC2022	AFP300	200	2"
AFTC2032	AFC2032	AFP400	300	3"
AFTC2042	AFC2042	AFP500	375	4"
AFTC2052	AFC2052	AFP600	475	5"

The Cool One – Accessories and Replacement Parts

Obsolete Replacement Parts

Auto-Fixed™ Finless Probes (7" to 10" long)

MATERIAL: AISI D-2 STEEL
HARDNESS: 50-55 HRC

These longer probes are ideal for larger molds or gating into deeper cavity configurations. The optional register ring shown below may be used to provide added stability at the probe tip if desired. Thermocouple heaters are guaranteed for one year as detailed under the heater chart below.

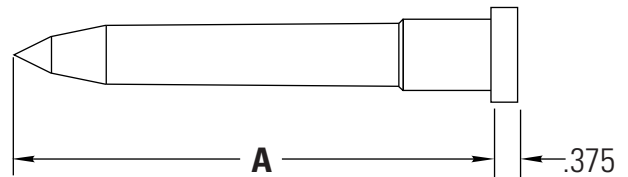

LENGTH A	ITEM NUMBER**
7.000	AFPN720
8.000	AFPN820
9.000	AFPN920
10.000	AFPN1020

**Includes probe, stop sleeve and hold down nut only.

Hold-Down Nut

(Packaged with all probes)

Thickness = .50
Thread = 1/4"-12
Hex Flat = 5/8



ITEM NUMBER

AFN125

Stop Sleeve

(Packaged with all probes)

Length = 1.375
Thread = 1/2"-20
Dia. = .500



ITEM NUMBER

AFSS12

Register Ring

AISI H-13 STEEL
48-52 HRC
I.D. = .693
O.D. = 1.500



ITEM NUMBER

AFRR20N

Thermocouple (T/C) Probe Heaters[†]

(.375 diameter, 240 VAC, T/C type J grounded, 46" leads)



ITEM NUMBER	FOR PROBE	WATTS	LENGTH
AFTC3272	AFPN720	645	7.15
AFTC3282	AFPN820	760	8.15
AFTC3292	AFPN920	870	9.15
AFTC32102	AFPN1020	980	10.15

[†]Thermocouple (T/C) Probe Heaters are guaranteed for one year from date of shipment.

Gate Insert

MATERIAL: AISI S-7 STEEL (pre-hardened)
HARDNESS: 30-34 HRC

Hardness can be increased to a higher value by heat treatment, if desired.

I.D. = 1.125 O.D. = 2000 Height = 2.500

ITEM NUMBER

AFGI20N



Adjustment Rings

Moldmaker to supply to suit (.990 O.D., .820 I.D.)

Modular Components Deliver High-Performance Solutions

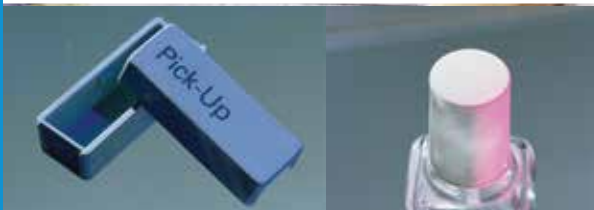

Today's increasingly feature-packed plastic products benefit tremendously from the right hot runner solution. Increasing resin costs and the complexity of engineered materials only compound this challenge. From hot sprue bushings to turnkey hot halves, DME offers a wide range of solutions to almost any molding application.

Get the modular advantage with DME hot runner systems

DME's newest family of hot runner systems are built on an architecture of modular components so we can quickly custom configure a system that is ideal for your application. With the tremendous time pressures on moldmakers today, our modular architecture enables industry-leading delivery times. This modular approach shortens delivery, improves cost-effectiveness and optimizes performance. DME's Meteor and Stellar hot runner systems offer standardized products, custom-configured to each application in only a few days.

Our dedicated team of application engineers works to understand the critical variables of your molding equation.

Here are a few areas in which our global capabilities make hot runner solutions more efficient and more economical.

Micromolding solutions

As plastic parts get smaller and more complex, micromolding solutions become more challenging. DME Stellar Hot Runner Systems were designed for the demands of very small part molding with engineered or commodity materials. The Stellar hot runner system is available for applications with center-to-center dimensions as close as 17mm.

Application engineered solutions

As an industry leader in hot runner systems, DME is able to offer our customers a comprehensive resource for hot runner solutions. Our dedicated team of application engineers works to understand the critical variables of your molding equation and engineer a hot runner system solution that is optimal for your project.

Powerful custom manufacturing capabilities

For more complex, custom and even high cavitation applications, DME offers extensive manufacturing capabilities enabling complete, custom solutions. For example, turnkey hot half systems — fully assembled, wired, and electrically tested — are ready to drop in with no machining and minimal installation demands.



DME

CONTROL SYSTEMS



Table of Contents



Smart Series® ITSP Plus Temperature Control System..... 114-119

Touch screen panel, powerful, flexible and affordable



Smart Series® Temperature Control Systems..... 120-161

RoHS/WEEE-compliant temperature controls for hot runner systems



Smart Series® Me Temperature Control System..... 162-163

Powerful performance made simple & economical



Smart Series® M2+ Temperature Control System..... 164-166

Advanced Hot Runner Temperature Control & Process Monitoring



Smart Series® Mt2 Temperature Control System..... 167-168

Precision control for 2-zone hot sprue applications



Valve Gate Controls..... 169-175

Energy efficient, reliable and compact hydraulic and pneumatic controls

Technical Support..... 176-177

*Customer power requirement worksheet
Breaker wattage size table
Control system repairs/calibrations
Product returns*

Smart Series® ITSP Plus™ Temperature Control System Series

POWERFUL, FLEXIBLE
AND AFFORDABLE



Features and Benefits

Everything you loved about the original TSP controller with new enhanced features for optimal control

- **Automatic Leak detection**
- Enhanced 7" Color Touch screen
- Storage : up to 100 Tools
- Optional Thermocouple to monitor steel temperature and alarm if cooling is off
- Accuracy 0.01 oF
- Ability to control Small Mass / High Watt density nozzles
- Field selectable PID (parameters) to optimize control process
- APS technology (Adaptive Process System)
- SPI communication Protocol via RS232/RS485 included
- Optional Full IO function card with 4 input + 4 output for communication (ordered separately - IOCARD-KIT)



ITEM NUMBER	SLOTS	# OF ZONES	MAIN
ITSP-12-15	2	12	40 AMPS
ITSP-24-15	4	24	63 AMPS
ITSP-36-15	6	36	
ITSP-48-15	8	48	

ITEM NUMBER	DESCRIPTION
ITSCGR-A	PCB replacement card, 6 zones @ 15 AMP

Custom zone configurations available upon request

ITSP Specifications

SMART SERIES USER-FRIENDLY PERFORMANCE

- Intuitive, leading edge touch screen display with adjustable viewing angle
- Automatically employed diagnostics to ensure optimal hardware configuration and performance
- Advanced micro controller technology
- Continuous ground fault and current measurement

PLUG-AND-PLAY SYSTEM ARCHITECTURE

- “All-in-one” control card designed for reliability
- Modular 6-zone cards; 15 amps per zone
- Field calibration mode
- Universal power supply

OPTIMIZES PERFORMANCE FOR ALL HOT RUNNER SYSTEMS

- Unique low voltage soft-start feature maximizes heater life
- Uniform startup feature reduces scrap and energy usage
- Proprietary adaptive auto-tuning control algorithm
- Phase angle or burst firing modes (time proportional, zero-crossing)









ROBUST, HIGH-QUALITY DESIGN

- Compact solid metal enclosure with heavy-duty industrial connectors
- Mold and controller protection features
- On-board heater and thermocouple fuses
- Portable stand available

IMPORTANT NOTICE: Smart Series Controllers are not designed to control all zones as manifold zones. Doing so will cause the main circuit breaker to trip.



ITSP Plus Component Ordering Information

ZONES	CONTROLLER	CABLES	TERMINAL MOUNTING BOX
12 ZONES OF CONTROL (15 AMP)	 <p><u>ITSP-12-15</u></p>	<p>MPC12C10G</p> <p>(1 each)</p> <p>TC12C10G</p>	<p><u>PTC12TBTS</u></p>  <p>(1 each)</p>
24 ZONES OF CONTROL (15 AMP)	 <p><u>ITSP-24-15</u></p>	<p>MPC12C10G</p> <p>(2 each)</p> <p>TC12C10G</p>	<p><u>PTC12TBTS</u></p>  <p>(2 each)</p>
36 ZONES OF CONTROL (15 AMP)	 <p><u>ITSP-36-15</u></p>	<p>MPC12C10G</p> <p>(3 each)</p> <p>TC12C10G</p>	<p><u>PTC12TBTS</u></p>  <p>(3 each)</p>
48 ZONES OF CONTROL (15 AMP)	 <p><u>ITSP-48-15</u></p>	<p>MPC12C10G</p> <p>(4 each)</p> <p>TC12C10G</p>	<p><u>PTC12TBTS</u></p>  <p>(4each)</p>

ITSP Plus Temperature Control System

Mold Power Cables (15 AMP Max)



[MPC12C10G](#)

ITEM NUMBER	ITEM NUMBER	ITEM NUMBER	NUMBER OF ZONES (MAX.)	FROM 15 AMP FRAME (S)	TO POWER INPUT CONNECTOR
10 FOOT LONG	20 FOOT LONG	30 FOOT LONG		FOR CONNECTIONS	
MPC12C10G	MPC12C20G	MPC12C30G	12	12 ZONE	PIC12G

Thermocouple Cables (for 15 or 30 AMP Mainframes)



[TC12C10G](#)

ITEM NUMBER	ITEM NUMBER	ITEM NUMBER	NUMBER OF ZONES (MAX.)	FROM 15 AMP FRAME (S)	TO POWER INPUT CONNECTOR
10 FOOT LONG	20 FOOT LONG	30 FOOT LONG		FOR CONNECTIONS	
TC12C10G	TC12C20G	TC12C30G	12	12 ZONE	MTC12G

- ITEM
- [ITS-TK15KVA](#)
- [ITS-TK30KVA](#)



480/240VAC Transformer and Trolley Assembly (controller not included)

- ITEM
- [ITSPTROLLEY](#)

Controller not included



- ITEM
- [ALARM BEACON](#)



ITSP Plus controllers do not come standard with wiring for the alarm beacon. Controller and beacon must be purchased together as a special.

Contact customer service at 800-626-6653 or dme@dme.net.

Smart Series®

ROHS/WEEE-COMPLIANT
TEMPERATURE CONTROLS
FOR HOT RUNNER SYSTEMS



RoHS/WEEE Compliant Advanced Temperature Control for Hot Runner Systems



Capability/RoHS and WEEE Compliant

DME offers 2-, 5-, 8-, and 12-zone standard mainframes for 15A operation and 1-, 2-, 3-, and 5-zone standard mainframes for 30A operation. Components listed in this catalog satisfy all international compliances. This includes RoHS (Restriction of Hazardous Substances) that prohibits or restricts the use of six potentially harmful materials in electronic equipment, and WEEE (Waste Electrical and Electronic Equipment) that requires equipment made after August 2005 to be taken back and recycled by the manufacturer, rather than just “thrown away.”

Two-Year Warranty

All DME temperature controllers are now covered by a two-year warranty, excluding fuses and triacs.

Electrical Noise Immunity

To enhance immunity from electrical noise, power and thermocouple wire are harnessed in separate wire ways within the body of the frame. Additional noise immunity is provided through the use of shielded thermocouple wires.

The DME Smart Series® is the result of intensive and dedicated research with a goal of designing today's most versatile and reliable line of temperature controllers. DME achieved this goal by not only incorporating the latest technology, but by also making certain that each controller is easy to install and above all...easy to operate.

Heavy Duty Welded Construction

With years of experience behind its design, the Smart Series line is built to last under the most rigorous conditions. The mainframe's welded 16 gauge steel construction ensures long life and peak performance. Cooling fans in the frame are strategically located to increase air ventilation, maintain cooler running conditions, and promote control module reliability.



CE COMPLIANT! DME Mainframes and Modules comply with Electromagnetic compatibility and low voltage directives



SSM1512



TSM1512

Control Modules

SSM (15 AMP): The SSM module provides accurate temperature control, including Smart Start® heater dry out circuitry, thermocouple fault displays and auto/manual modes of operation. The SSM features automatic or manual bumpless transfer which, in the event of a thermocouple fault, provides switch over to manual mode at the proper power setting to continue molding until the fault can be corrected. This module can also trigger remote standby heat (idle), boost, off, and alarm functions when used with the TAS module.

TSM (15 AMP): The TSM15 Smart Series Module has a color touch screen digital display providing readouts for Actual Temperature, Current Mode, Percentage Power and Current Reading. Closed-loop, fuzzy logic PID control, and auto-tuning of PID parameters provide precise control even under the most adverse processing conditions..

Accessory Modules

TAS: The TAS module provides over/under visual and audible alarms, boost, and standby heat control with control modules as stated above. The TAS module can accommodate up to 63 zones of control. Alarm is activated at $\pm 30^\circ$ F. See pages 143-144 for details.

NOTE: The TAS accessory module requires the use of "MFC" style communications mainframes. Non-communications frames may be upgraded on-site with installable kits.

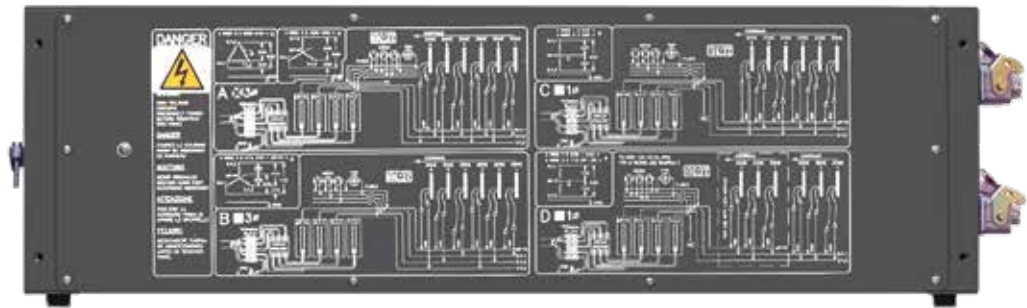

Simplified Power Hook-Up

Concern for user convenience didn't stop with improved operation features. DME went one step beyond to ensure that the power hook-up procedure goes smoothly as well. For this reason, detailed schematics for various hook-ups are provided directly on all mainframe back panels. If it is ever necessary to change the configuration, these diagrams will help ensure wiring diagrams can be referenced at the end of this section.

SSH Controller (10 AMP)

The SSH is a stand-alone single zone controller ideal for use with hot sprue bushings or machine nozzles.



SSH1022

Smart Series® Temperature Control Systems

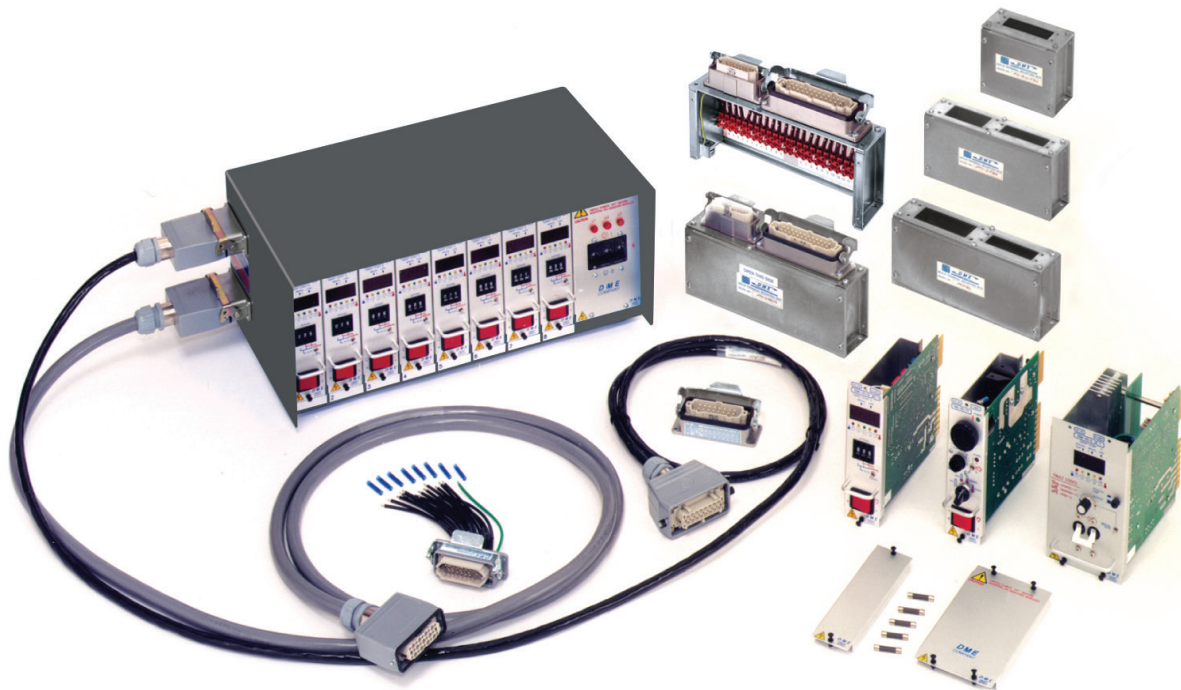

- ① Mainframe
- ② Circuit Breaker/Disconnect
- ③ Mold Power Cable
- ④ Thermocouple Cable
- ⑤ Mold Power Input Connector
- ⑥ Insulated Crimp Connector
- ⑦ Thermocouple Connector
- ⑧ Terminal Mounting Boxes
- ⑨ Mainframe Blank Panels
- ⑩ Module Replacement Fuses
- ⑪ Control Modules

Typical System Configurations

SSM1512
TSM1512

5 Zones of Control (15 AMP)



X5

+



MFP5G

+



MPC5C10G

+



TC5C10G

PTC5TBTS



+



MFS512G

SSM1512
TSM1512

8 Zones of Control (15 AMP)



X8

+



MFP8G

+



MPC8C10G

+



TC8C10G

PTC8TBTS



+



MFS512G

SSM1512
TSM1512

12 Zones of Control (15 AMP)



X12

+



MFP12G

+



MPC12C10G

+



TC12C10G

PTC12TBTS



+



MFS512G

RoHS/WEEE Compliant Smart Series® Single Zone Temperature Controller

SSH1022/

- Compact
- Easy-to-use
- Includes new, improved and unique features
- Provides microprocessor- based PID control
- More accurate than analog or variac controllers
- Built-in thermocouple diagnostics
- Ideal for use with a hot sprue bushing or a machine nozzle



Key Features

- **Large Digital Display**
 - For easier readability of temperature, % power and faults
- **Setpoint Pushwheel**
 - For setting desired setpoint temperature
 - Allows adjustment of setpoint before turning power on
- **AUTO % Power Display**
 - Shows % power output while in AUTO mode
 - Indicates average % power requirement on thermocouple failure
 - A diagnostic tool for solving problems

Switchable Options

- **Shorted Thermocouple Sensitivity Adjustment**
 - Operation can be tailored to fast or slow reaction times
 - Sensitivity can be adjusted with internal switches
 - Very useful for zones with long startup times
- **Switchable °C/°F Operation**
 - Scale indicated at startup
- **K Type Thermocouple Support**
- **Cut Feature**
 - Gain cut feature for small nozzles and heaters with ungrounded internal thermocouples

Operational Refinements

- **Improved SmartStart®**
 - A more gradual temperature rise leads to a more effective heater dry out period, thereby extending heater life
 - SmartStart® now available as an option in manual mode
- **SelectiveCycle®**
 - A very high speed power output approach
 - Enables accurate temperature control and longer heater life
- **Bumpless Transfer**
 - When a thermocouple failure occurs, operation is automatically continued with a learned % power
 - Unique software accurately assigns percent power setting
- **Third Fuse**
 - Allows for display of low temperature alarm when the load fuses are blown

Front Panel Digital LED Indicators

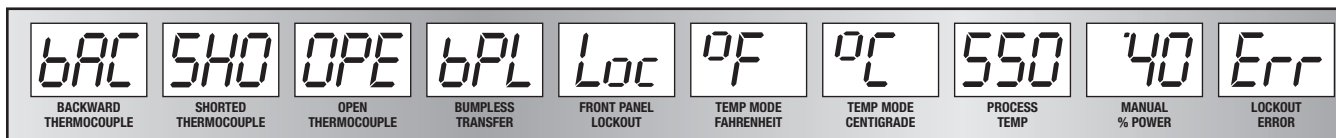

RoHS/WEEE Compliant Smart Series® Single Zone Temperature Controller

SSH1022

Controller includes 19-foot power cord, mating mold power and thermocouple connector (CKPTM1) and two spare fuses (ABC10). Additional cables and/or connectors must be ordered separately. See Page 121 for detailed information on cables and connectors.
Warranty: Two year (excluding triac and fuses).

CONTROLLER ITEM NUMBER	VOLTS (VAC)
SSH1022	240

CABLE* ITEM NUMBER	LENGTH (FEET)
MPTC10	10
MPTC20	20

See page 119



MOLD POWER AND THERMOCOUPLE CONNECTOR* ITEM NUMBER
CKPTIC1

See page 119



*** ITEMS ORDERED SEPARATELY**

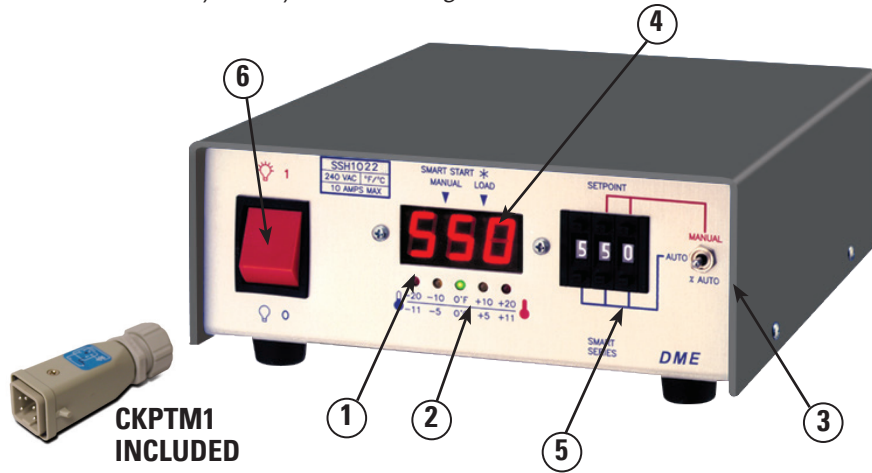

CKPTM1 INCLUDED

Front Panel Controls and Indicators

- Process Temperature Display:**
Shows process temperature, thermocouple faults and other operational modes. Displays % power when switch (3) is pressed down.
- Temperature Deviation Lights:**
Indicates deviation from setpoint. Outer lights blink at more than $\pm 40^{\circ}\text{F}$ (22°C) from setpoint.
- Auto / Manual / % Auto Power Switch:**
Selects AUTO or MANUAL control mode. Shows % power when pressed into “% AUTO” position.
- LED Mode Indicators:**
Left LED illuminates during manual mode. Right LED illuminates when power is supplied to heater. Right LED blinks during SmartStart®.
- Setpoint Pushwheel:**
Three digit switch programs setpoint in AUTO mode. Right two digits program % power in MANUAL mode.
- Power On/Off Switch:**
Controls AC power to module.

Rear Panel

- Mold Power and Thermocouple Output Connector:**
CKPTIC1 connects to the heater and thermocouple. Mating connector CKPTM1 is supplied with controller.
- Power Input Cord:**
Nineteen foot cord supplies power to controller. Plug supplied with SSH1021 (120 VAC) units. No plug supplied with SSH1022.
- Load Fuse Receptacles:**
Provides safe and easy replacement of load fuses.

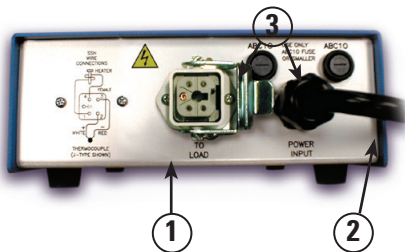

RoHS/WEEE Compliant Smart Series® Single and 2-Zone Mainframes (10 AMP max.)



MFP1G
MFP1G1

A: AC2024F (Power to Mainframe);
AC1512F supplied with MFP1G1

B: CKPTM1 (Connector to heater)

This single-zone controller is ideal for use with Straight-Shot and Gate-Mate hot sprue bushings.



MFPR2G

A: AC2024F (Power to Mainframe)

B: CKPTM1 (Connector to heater)

**Single zone, horizontal
10 amp controllers
(SSH1022/21) also
available. See page 116**

DIMENSIONS

(all frames)
7"W x 9"H x 10"D
(9"H dimension does not
include connectors or handle)

Single and Two-Zone 10 AMP Mainframes

The DME Portable 10 AMP Mainframes are designed for use with 10 or 15 AMP* Smart Series or G-Series Temperature Control Modules. Mainframe is supplied with power input and power-thermocouple output connectors. Circuit breaker provides safety for operation. Control modules and cables are to be ordered separately.

NOTE: Maximum safe operating amperage is 10 AMPS per zone when using 15 AMP modules. If application will draw more than 10 AMPS per zone, use 15 AMP Mainframe (MFFPR2G).

*User must install ABC10 (10 AMP) fuses in the 15 AMP control modules to protect the mainframe.

Single and Two-Zone 10 AMP Mainframes (50-60 Hz, single phase)

ZONES	ITEM NUMBERS **	VOLTS	WATTS PER ZONE	CONNECTORS SUPPLIED
1	MFP1G1	120	1200	(1) AC1512F (POWER IN) (1) CKPTM1 (POWER-T/C OUT)
1	MFP1G	240	2400	(1) AC2024F (POWER IN) (1) CKPTM1 (POWER-T/C OUT)
2	MFPR2G	240	2400	(1) AC2024F (POWER IN) (2) CKPTM1 (POWER-T/C OUT)

**Includes frame and connectors listed. Modules and cables ordered separately.

NOTE: Replacement power connectors in frame are also available on special order.

Recommended Mold Pocket Layout

(For Mold Power-Thermocouple Input Connector CKPTIC1)

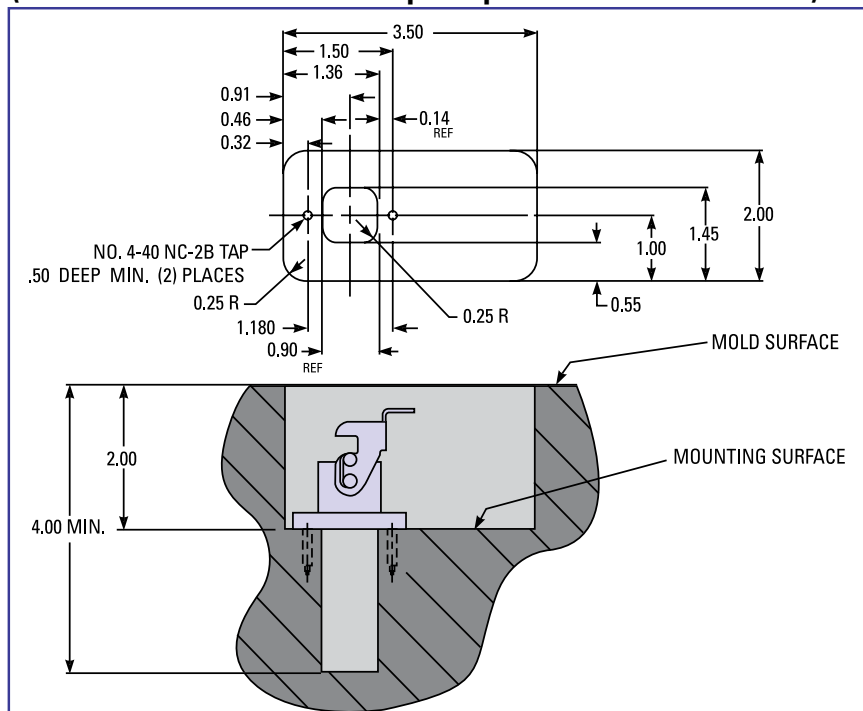

RoHS/WEEE Compliant: Smart Series® Single and 2-Zone Mainframe Accessories (10 AMP)

For Use With MFP1G, MFP1G1, MFPR2G, SSH1022 and SSH1021

Mold Power-Thermocouple Input Connector

ITEM NUMBER
CKPTIC1



A Single-Zone Power-Thermocouple Input Connector is available for mounting in or on the mold to accept the power-thermocouple cable from the mainframe. Water resistant, the connector has an integral retaining latch for a secure cable connection and numbered screw-type terminals for power and thermocouple lead wires.

*Can be mounted on top of mold for use with hot sprue bushings.

Armored Mold Power-Thermocouple Cables

ITEM NUMBER
MPTC10
MPTC20



Single-Zone Mold Power-Thermocouple Cables are constructed of special lead wire for use in high temperature environments, and are available to connect the mainframe to the connector on the mold. Available in lengths of 10 or 20 feet. Integral retaining latches on the mainframe and mold connections provide secure cable connections. Connector configurations ensure proper insertion of cable.

Replacement Connector Kits (for Controller & Cables)

MALE POWER – T/C CONNECTORS:

- CKPTM1 is on MPTC10/20 Cables; Mates with Frame or CKPTF1L only
- CKPTM1L Mates With CKPTF1 only

FEMALE POWER – T/C CONNECTORS:

- CKPTF1 is on MPTC10/20 Cables; Mates with Mold or CKPTM1L only
- CKPTF1L Mates with CKPTM1 only

Power Input Connectors For Mainframe



AC1512F



CKPTM1



CKPTF1



PTC210



AC2024F



CKPTM1L



CKPTF1L

ITEM NUMBER	VOLTS
AC1512F	120
AC2024F	240

ITEM NUMBER
CKPTM1
CKPTM1L

ITEM NUMBER
CKPTF1
CKPTF1L

ITEM NUMBER
PTC210

Power-Thermocouple Output Connector (for Mainframe Bulkhead)

ITEM NUMBER
CKPTOC1

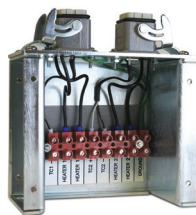

ITEM NUMBER
PTC210TBGTS

Terminal Mounting Boxes – Prewired (10 AMP) 5 Pin

Terminal Mounting Boxes provide the easiest and most economical method of mounting power and thermocouple connectors on the mold. Constructed of plated heavy gauge steel, each box is pre-cut and drilled for quick mounting of the box to the mold (2-zone, prewired terminal mounting box with terminal strip shown with cover plate removed).

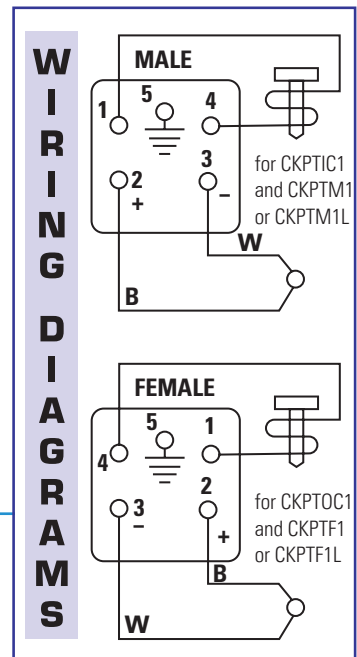

Smart Series® 2-Zone Mainframes (15 AMP) and Accessories

MFFPR2G



Two-Zone 15 AMP Mainframes

Provides 15 AMP (3600 watts) per zone. For use with Smart Series or G-Series modules. Supplied with built-in cooling fan, power input, power output and thermocouple input connectors. Control modules and cables are ordered separately.

TWO-ZONE 15 AMP MAINFRAME (240 VAC, 50-60 Hz, SINGLE PHASE)

ITEM NUMBER	WATTS PER ZONE	CONNECTORS SUPPLIED
MFFPR2G	3500	(1) AC1240F (POWER IN) (1) AC1524M (POWER OUT) (2) M2MJ (T/C IN)

Includes frame and connectors listed. Modules and cables ordered separately.

NOTE: Replacement parts in frame are also available by special order. See pages 146-147.

FRAME DIMENSIONS:

7"W x 9"H x 10"D
(9"H dimension does not include connectors or handle)

ITEM NUMBERS	DESCRIPTION
AC1240F*	Female 240 VAC twist-lock power input connector (mates with male frame power input)
AC1524M*	Male 240 VAC power output connector (mates with female frame power outputs)
M2MJ*	Thermocouple mini-plug (mates with frame jack strip connector)
PTC2TBGTS	2 zone, pre-wired terminal mounting box with terminal strip (mounts to mold; mates with PTC0110 or PTC0129 cables)

* Included with MFFPR2G



ITEM NUMBER
PTC0110
PTC0120

For use with MFFPR2G only

Armored Mold Power – Thermocouple Cables (15 AMP)

Single-Zone Mold Power-Thermocouple Cable is constructed of special lead wire for use in high temperature environments. This cable connects the mainframe to the connector on the mold. Available in lengths of 10 or 20 feet. Retaining latches on the mold connector provide secure cable connections.

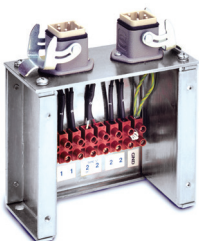

ITEM NUMBER
PTC2TBGTS

For use with MFFPR2G only

Terminal Mounting Boxes – Prewired (15 AMP)

Terminal Mounting Boxes provide the easiest and most economical method of mounting power and thermocouple connectors on the mold. Constructed of plated heavy gauge steel, each box is pre-cut and drilled for quick mounting of the box to the mold (2-zone, prewired terminal mounting box with terminal strip shown with cover plate removed).

NOTE: 6-pin connectors and pins are available as a special order only. These are crimp contacts. (See pages 148-149 for mounting dimensions.)

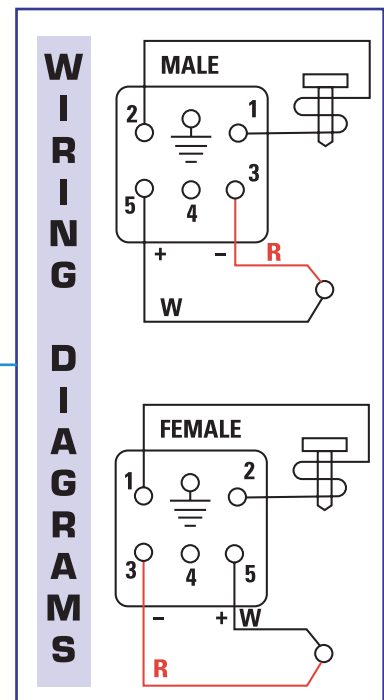

Smart Series® Single Zone High Power Mainframes (30 AMP Max.)

MFHP1G



The DME Portable Single-Zone High Power Mainframe is designed for use with 30 AMP Smart Series or G-Series temperature control modules. Mainframe is supplied with built-in cooling fan, power input, power output, and thermocouple input connectors. Circuit breaker provides safety for the operator. Control modules and cable are ordered separately.

Single Zone 30 AMP Mainframes (240 VAC, 50-60 Hz, Single Phase)

ITEM NUMBER	WATTS (OUTPUT)	CONNECTORS SUPPLIED
MFHP1G	7200	(1) AC1240F (POWER IN) (1) AC1240M (POWER OUT) (1) M2MJ (T / C IN)

Replacement Connectors and Accessories

ITEM NUMBER	DESCRIPTION
MPCH110	10 ft. mold power cable (240 VAC) (1 AC1240F twist-lock connector on mold end; 1 AC1240M twist-lock connector on frame end)
MPCH120	20 ft. mold power cable (240 VAC) (same connectors as MPCH110)
AC1240MI	1-Zone twist-lock mold power input connector (mounts in mold or terminal mounting box; accepts AC1240F twist-lock connector or MPCH110 or MPCH120 cable)
TC120	20 ft. thermocouple cable (1 M2MJ mini-plug each end)
AC1240F*	240 VAC twist-lock power input connector (mates with frame power input)
AC1240M*	240 VAC twist-lock power output connector (mates with frame power output)
M2MJ*	thermocouple mini-plug (mates with frame or jack strip connector)
PTCH1TBG	terminal mounting box (mounts to mold; accepts 1 AC1240MI and 1 TCS1)
TCS1	jack strip connector

This product is no longer available

FRAME DIMENSIONS:
7"W x 9"H x 10"D
(9"H dimension does not include connectors or handle)

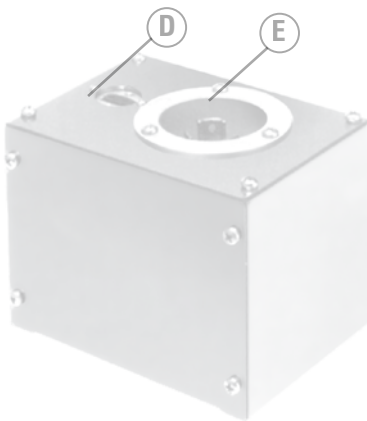

TERMINAL MOUNTING BOX PTCH1TBG
(Connectors shown are ordered separately)
D: TCS1
E: AC1240MI

*Included with MFHP1G mainframe

TERMINAL MOUNTING BOX PTCH1TBG

NOTE: Overall dimensions shown include allowances for hardware (assembly screws) but not connectors.

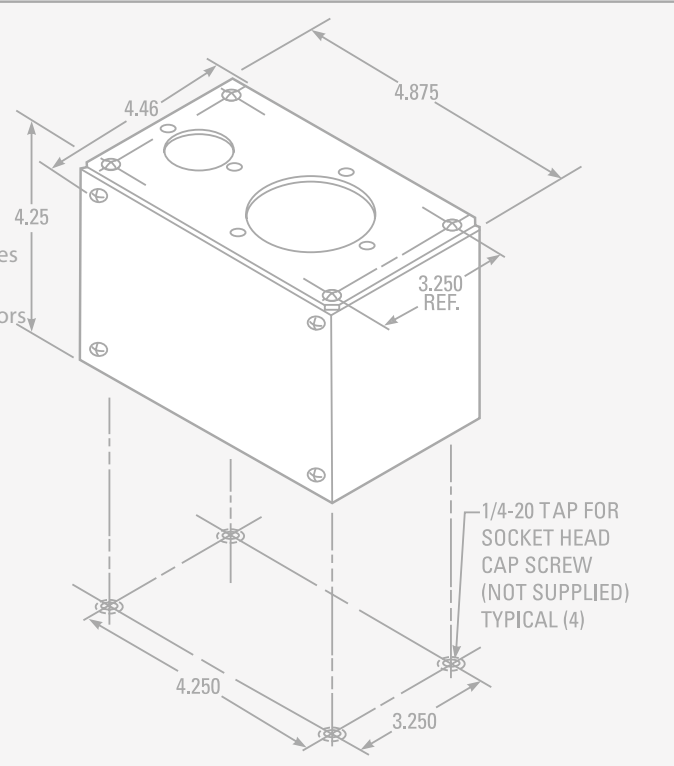

Smart Series® Mainframes (15 AMP)

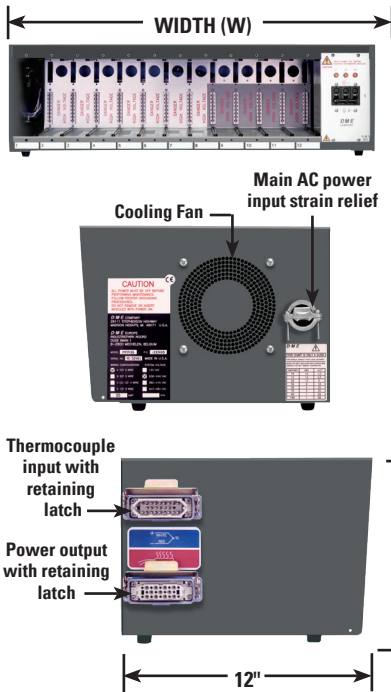

Smart Series® Mainframe (15 AMP Max.) Configurations

The 12 configurations illustrated below provide a wide selection of zone capacities to suit most control applications. The 5-, 8- and 12-zone frames (MFP5, 8, and 12G) use individual frame sections. The 16 thru 48 zone frames use 2, 3, or 4 frame sections rigidly fastened together into one prewired integral unit which requires only one main AC power input connection. The Current Voltage monitor option will be factory installed when ordered at same time as Mainframe. Control modules, cables, mold connectors and other accessories are ordered separately (see table on next page).

MAINFRAMES (Supplied with 50 AMP, 3-phase circuit breaker)

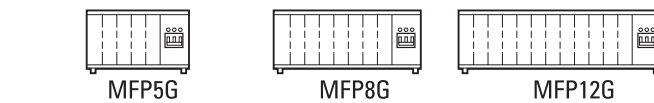

STACK FRAMES (Supplied with 70 AMP, 3-phase circuit breaker)

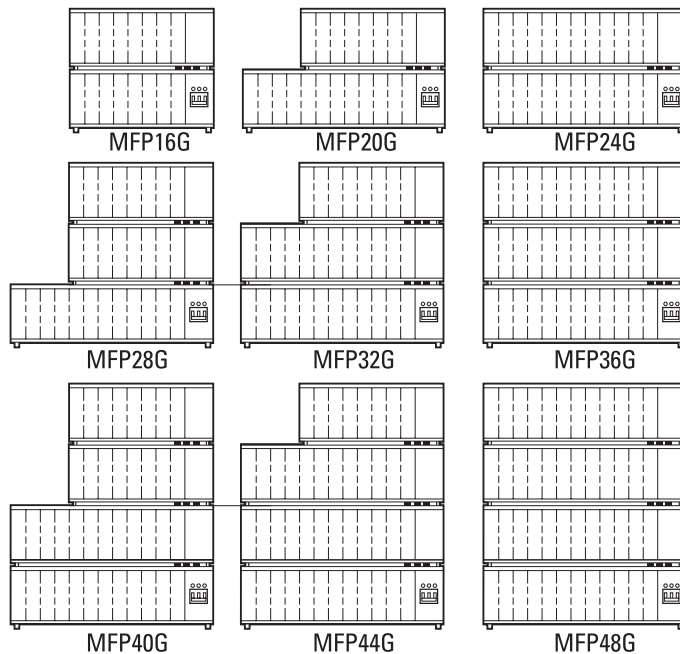

- Each frame section (MFP5G, MFP8G, and MFP12G) has its own cooling fan.
- Multi-section frame heights are multiples of 9" height shown (e.g. MFP32G is 27" high).
- Main AC input shown will always be in bottom frame section. For higher power requirements, individual power inputs and circuit breakers can be factory installed in each section of a stack frame on a special order basis.

WORLDWIDE WIRING CAPABILITIES

Unless otherwise specified, all Smart Series Mainframes will be supplied to accept 240 VAC, 3 phase, 4-wire, 50-60 Hz input power. Wiring diagram (included on the access cover) illustrates the variety of other voltage, phase and load balancing arrangements possible, such as: (380-415V, 3 phase, 5-wire, 50-60 Hz), (208-240V, single phase, 3-wire, 50-60 Hz) and (110-120V, single phase, 3-wire, 50-60 Hz).

These wiring adjustments can be performed in the field to suit the requirements of the application. If specified at the time of original order, DME will supply the Mainframe required.

ITEM NUMBER	W*
MFP5G	14 ³ / ₁₆
MFP8G	20 ³ / ₁₆
MFP12G	28 ³ / ₁₆

* Dimension does not include connectors

NOTE: Combination frames to accommodate both 15 and 30 AMP modules (with or without communications) are available by special order.

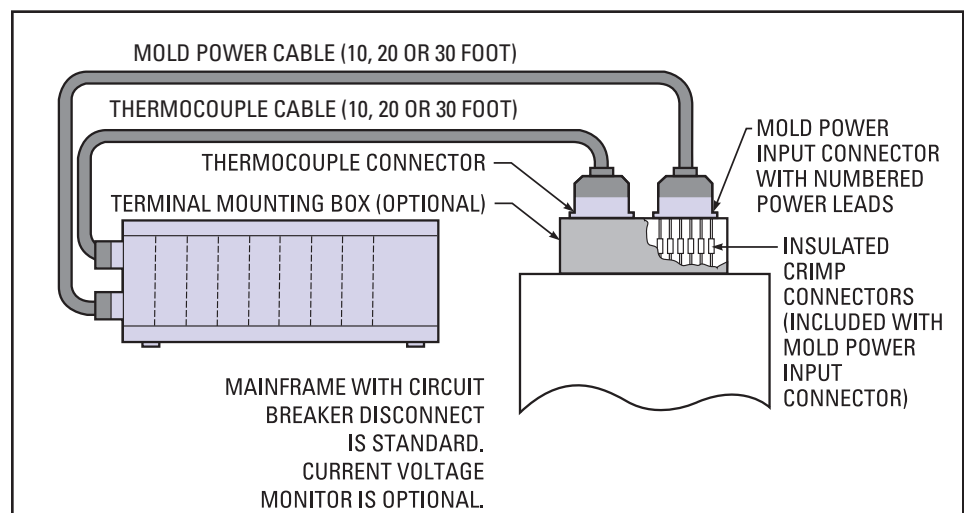

Smart Series® Mainframes (15 AMP)

Smart Series Mainframes

Cables & Connectors

SMART SERIES MAINFRAMES				CABLES AND MOLD CONNECTORS REQUIRED (Not included with Mainframes and Must be Ordered Separately)							
ZONES	"MFP" TYPE FOR TEMP. AND POWER CONTROL		"MFPC" TYPE FOR TEMP. CONTROL AND COMMUNICATIONS	MOLD POWER CABLES C10=10 FT. C20=20 FT. C30=30 FT. (SELECT LENGTH DESIRED)		THERMOCOUPLE CABLES C10=10 FT. C20=20 FT. C30=30 FT. (SELECT LENGTH DESIRED)		MOLD POWER INPUT CONNECTORS (INCL. CRIMP CONNECTORS)		THERMOCOUPLE CONNECTORS	
	ITEM NUMBER		ITEM NUMBER	QTY.	ITEM NUMBER	QTY.	ITEM NUMBER	QTY.	ITEM NUMBER	QTY.	ITEM NUMBER
5	MFP5G		MFPC5G	1	MPC5C10G, C20G or C30G	1	TC5C10G, C20G or C30G	1	PIC5G	1	MTC5G
8	MFP8G		MFPC8G	1	MPC8C10G, C20G or C30G	1	TC8C10G, C20G or C30G	1	PIC8G	1	MTC8G
12	MFP12G		MFPC12G	1	MPC12C10G, C20G or C30G	1	TC12C10G, C20G or C30G	1	PIC12G	1	MTC12G
16	MFP16G		MFPC16G	2	MPC8C10G, C20G or C30G	2	TC8C10G, C20G or C30G	2	PIC8G	2	MTC8G
20	MFP20G		MFPC20G	1	MPC8C10G, C20G or C30G	1	TC8C10G, C20G or C30G	1	PIC8G	1	MTC8G
				1	MPC12C10G, C20G or C30G	1	TC12C10G, C20G or C30G	1	PIC12G	1	MTC12G
24	MFP24G		MFPC24G	2	MPC12C10G, C20G or C30G	2	TC12C10G, C20G or C30G	2	PIC12G	2	MTC12G
28	MFP28G		MFPC28G	2	MPC8C10G, C20G or C30G	2	TC8C10G, C20G or C30G	2	PIC8G	2	MTC8G
				1	MPC12C10G, C20G or C30G	1	TC12C10G, C20G or C30G	1	PIC12G	1	MTC12G
32	MFP32G		MFPC32G	1	MPC8C10G, C20G or C30G	1	TC8C10G, C20G or C30G	1	PIC8G	1	MTC8G
				2	MPC12C10G, C20G or C30G	2	TC12C10G, C20G or C30G	2	PIC12G	2	MTC12G
36	MFP36G		MFPC36G	3	MPC12C10G, C20G or C30G	3	TC12C10G, C20G or C30G	3	PIC12G	3	MTC12G
40	MFP40G		MFPC40G	2	MPC8C10G, C20G or C30G	2	TC8C10G, C20G or C30G	2	PIC8G	2	MTC8G
				2	MPC12C10G, C20G or C30G	2	TC12C10G, C20G or C30G	2	PIC12G	2	MTC12G
44	MFP44G		MFPC44G	1	MPC8C10G, C20G or C30G	1	TC8C10G, C20G or C30G	1	PIC8G	1	MTC8G
				3	MPC12C10G, C20G or C30G	3	TC12C10G, C20G or C30G	3	PIC12G	3	MTC12G
48	MFP48G		MFPC48G	4	MPC12C10G, C20G or C30G	4	TC12C10G, C20G or C30G	4	PIC12G	4	MTC12G

NOTE: For details on cables and connectors, see pages 130-132.

Terminal Mounting Boxes

ZONES	ORDER ITEMS A and B or C					
	(A) FOR POWER INPUT CONNECTORS		(B) FOR THERMOCOUPLE CABLES CONNECTORS		(C) COMBINATION POWER & TC	
	QTY.	ITEM NUMBER	QTY.	ITEM NUMBER	QTY.	ITEM NUMBER
5	1	PIC512TBG	1	MTC5TBG	1	PTC5TBG
8	1	PIC512TBG	1	MTC8TBG	1	PTC8TBG
12	1	PIC512TBG	1	MTC12TBG	1	PTC12TBG
16	2	PIC512TBG	2	MTC8TBG	2	PTC8TBG
20	2	PIC512TBG	1	MTC8TBG	1	PTC8TBG
			1	MTC12TBG	1	PTC12TBG
24	2	PIC512TBG	2	MTC12TBG	2	PTC12TBG
28	3	PIC512TBG	2	MTC8TBG	2	PTC8TBG
			1	MTC12TBG	1	PTC12TBG

ZONES	ORDER ITEMS A and B or C					
	(A) FOR POWER INPUT CONNECTORS		(B) FOR THERMOCOUPLE CABLES CONNECTORS		(C) COMBINATION POWER & TC	
	QTY.	ITEM NUMBER	QTY.	ITEM NUMBER	QTY.	ITEM NUMBER
32	3	PIC512TBG	1	MTC8TBG	1	PTC8TBG
			2	MTC12TBG	2	PTC12TBG
36	3	PIC512TBG	3	MTC12TBG	3	PTC12TBG
40	4	PIC512TBG	2	MTC8TBG	2	PTC8TBG
			2	MTC12TBG	2	PTC12TBG
44	4	PIC512TBG	1	MTC8TBG	1	PTC8TBG
			3	MTC12TBG	3	PTC12TBG
48	4	PIC512TBG	4	MTC12TBG	4	PTC12TBG

NOTES: Combination terminal mounting boxes are available with connectors prewired to terminal strips. See page 135 for details. See page 136 for dimensional details. For below flush mounting of connectors, see mold pocket layouts on pages 133-134. See page 125 for current voltage monitor.

Smart Series® High Power Mainframes (30 AMP)

This product is no longer available

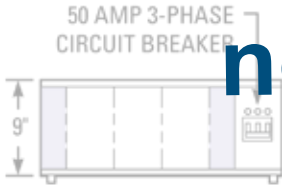
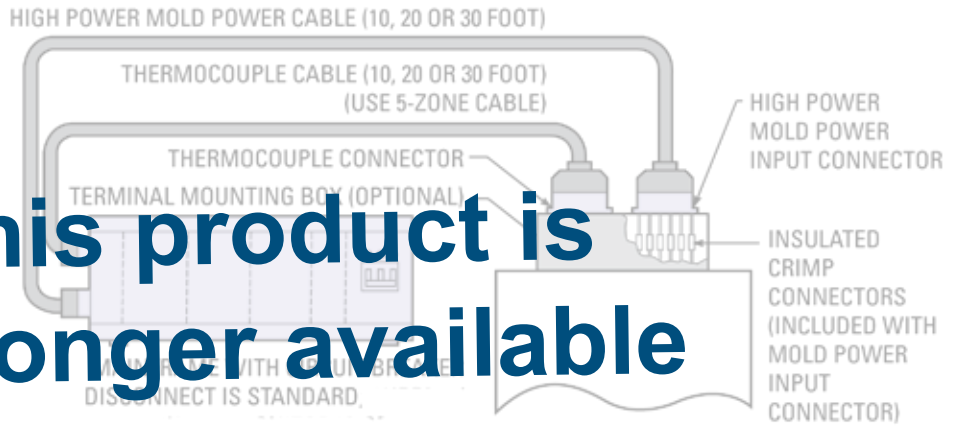

MFHP3G
(20 3/16" WIDE)

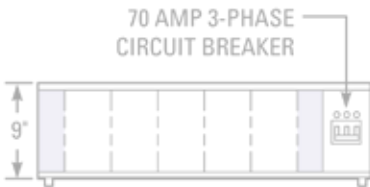

MFHP5G
(28 3/16" WIDE)

DIMENSIONS ABOVE DO NOT INCLUDE CONNECTORS

all frames are 12" deep

NOTE: Blank panels cover unused zones in frames (shaded panels above). For communications (MFCHP) type frames, these zones may be used for communication modules.



NOTE: Combination frames to accommodate both 15 and 30 AMP modules (with or without communications) are available by special order.

The 3 configurations illustrated at left provide 2, 3 or 5-zones of 30 AMP control for higher wattage heater applications. The Current Voltage monitor option will be factory installed when ordered at the same time as Mainframe. Control modules, cables, mold connectors and other accessories are ordered separately.

SMART SERIES HIGH POWER MAINFRAMES		
Optional Current Voltage Monitor is Factory Installed in CV-Style Frames		
ZONES	"MFHP" TYPE FOR TEMP. CONTROL	"MFCHP" TYPE FOR TEMP. CONTROL AND COMMUNICATIONS
	ITEM NUMBER	ITEM NUMBER
3	MFHP3G	MFCHP3G
5	MFHP5G	MFCHP5G

CABLES AND MOLD CONNECTORS REQUIRED										
(Not included with Mainframes and Must be Ordered Separately)										
ZONES	MOLD POWER CABLES C10=10 FT. C20=20 FT. C30=30 FT. (SELECT LENGTH DESIRED)			THERMOCOUPLE CABLES C10=10 FT. C20=20 FT. C30=30 FT. (SELECT LENGTH DESIRED)			MOLD POWER INPUT CONNECTORS (INCL. CRIMP CONNECTORS)		THERMOCOUPLE CONNECTORS	
	QTY.	ITEM NUMBER	QTY.	ITEM NUMBER	QTY.	ITEM NUMBER	QTY.	ITEM NUMBER		
2	1	MPCH23C10G, C20G or C30G	1	TC5C10G, C20G or C30G	1	PICH23G	1	MTC5G		
3	1	MPCH23C10G, C20G or C30G	1	TC5C10G, C20G or C30G	1	PICH23G	1	MTC8G		
5	1	MPCH5C10G, C20G or C30G	1	TC5C10G, C20G or C30G	1	PICH5G	1	MTC12G		

NOTE: For details on cables and connectors, see pages 130-132.

Terminal Mounting Boxes

ZONES	ORDER ITEMS A and B or C					
	(A) FOR POWER INPUT CONNECTORS		(B) FOR THERMOCOUPLE CABLES CONNECTORS		(C) COMBINATION POWER & TC	
	QTY.	ITEM NUMBER	QTY.	ITEM NUMBER	QTY.	ITEM NUMBER
2	1	PICH23TBG	1	MTC5TBG	1	PTCH23TBG
3	1	PICH23TBG	1	MTC5TBG	1	PTCH23TBG
4	1	PICH5TBG	1	MTC5TBG	1	PTCH5TBG

NOTE: See page 135-136 for dimensional details. For below-flush mounting of connectors, see mold pocket layouts on pages 133-134.

Smart Series® Digital Current/Voltage Monitor

Streamlined Design For Improved Performance

The new Current/Voltage Monitor is simple to operate and features a large easy-to-read digital display. Ease of operation has been enhanced by streamlining the unit and eliminating unnecessary switches and controls. When setting the selector switch to the desired zone number, the 'AMPS' function is selected. The meter will then display the amount of current being delivered by the selected module. Input voltage to the system can be measured by rotating the selector switch to one of the three 'line voltage' positions. This will set the meter in the 'voltage' function and display the voltage of the selected phase.

Current Supply To Each Zone

To monitor the current supply to each zone, simply set the rotary selector switch to the desired module zone number. The "AMPS" function is then automatically selected and is indicated by the letter 'A' just to the right of the numbers in the display window. The meter displays the current being delivered to the heater load in amperes.

Input Voltage From Each Phase

Set the rotary selector to the desired phase voltage position. This automatically selects the 'volts' function which is indicated when the letter 'V' appears to the right of the numbers in the display window. The meter will display the line voltage of the selected phase.

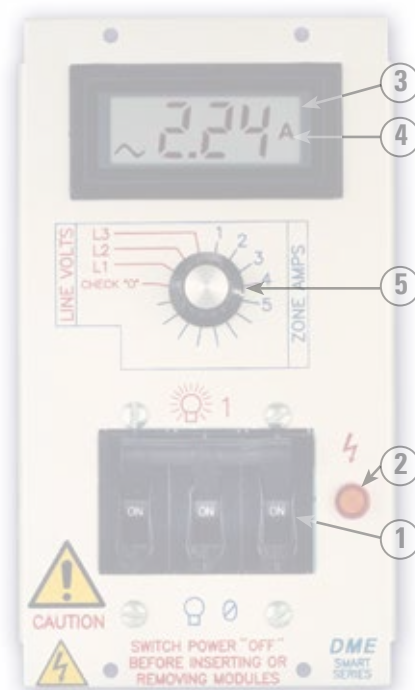

**This product is
no longer available**

- 1. CIRCUIT BREAKER/DISCONNECT** – Applies or removes power to all modules in the frame.
- 2. POWER ON LIGHT (amber)** – Illuminates when CIRCUIT BREAKER is in the ON position.
- 3. AMPS/VOLTS METER** – Digital multi-scale meter provides accurate readings of zone current (AMPS) or input voltage (VOLTS).
- 4. AMPS/VOLTS INDICATOR** – Appears automatically when either AMPS or VOLTS is selected.
- 5. SELECTOR SWITCH** – Multi-position switch automatically selects zone current or phase line voltage to be monitored. For systems with more than 12-zones, additional meter and selector switch panels are supplied.

Specifications

Voltmeter Range	190 to 290 VAC (for 240 volt systems) 90 to 145 VAC (for 120 volt systems)
Voltmeter Accuracy	± 3% of reading, 50 to 60 Hz
Maximum Voltmeter Input	400 VAC
Input Voltage	240/120 VAC, 50 to 60 Hz
Ammeter Range	0 to 2; 0 to 30; 0 to 40 Amperes
Ammeter Accuracy	± 2% @ 0 to 100% Duty Cycle, 50-60 Hz
Maximum Ammeter Input	30 Amperes

NOTE: The Digital Current/Voltage Monitor is a factory installed option which replaces the standard circuit breaker/disconnect, and is supplied when "CV-style" mainframes are ordered.

See pages 123 and 124 for appropriate mainframe item numbers.

Smart Series® Accessories

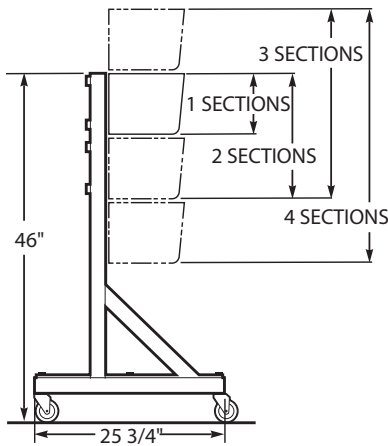

Universal Floor Stand

The Universal Floor Stand will accommodate all 15 or 30 amp Mainframes from one to four sections high. Stand is made from heavy gauge steel and includes locking casters (400 lb. rating). All assembly and Mainframe mounting hardware is included. Heavy duty floor stand available for larger systems (1000 lb. rating).

ITEM NUMBER	RATING
MFS512G	400 LBS
MFS512GHD*	1000 LBS

* HD stand not shown.

Floor stand comes with plates for 5-zone frame mounting on 8-zone "x" pattern

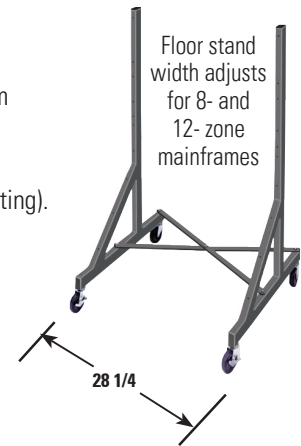

Step-Down Transformer Kits (from 480 VAC to 240 VAC)

Transformer Kits are pre-wired and include enclosed transformer (480 VAC input, 240 VAC output) with adjustable transformer voltage taps, one 10-foot cable for AC power-in (no connector), one 6-foot cable for mainframe (AC input), one safety switch, two extra fuses, floor stand (MFS512G) and all mounting brackets and hardware required. Shipped with instructions for easy assembly.

Single section frames mount to front or rear of stand.

ITEM NUMBER	RATING
TK91AG*	9 KVA
TK151AG*	15 KVA
TK301AG**	30 KVA

Mainframe not included.

Adapter plates for narrower frames available by special order.

* Comes with plates for mounting 8-zone on 12-zone "x" pattern

** Supplied with MFS512GHD for this transformer size or larger and transformers mounted flat.

NOTE: Power capacity needed depends on total load of system (i.e. number of zones and heater load per zone).

Also Available:

1. Transformer only
 2. Transformer and cables only
 3. Transformers with other voltage or current capacities
 4. Isolation Transformers
- Contact DME for details and prices.



Mainframe Blank Panels

Used. to cover unused zones in mainframes. Push-pull fasteners included in panel.

MFBP10G covers one 15 AMP zone;

MFBP30G covers one 30 AMP zone (or two 15 AMP zones).

ITEM NUMBER
MFBP10G
MFBP30G

Module Replacement Fuses

(sold in packages of 5)



ITEM NUMBER	AMPS
ABC1	1
ABC15	15
ABC10	10
13X10	10
13X15	15
RPM0123	15
RPM0124	.062

Insulated Crimp Connectors

For connection of mold power input connector leads to heater leads. (195°F / 90°C maximum temperature)



ITEM NUMBER	AMPS	RATING
HWCC1 (Bag of 30)	10-15	16-22 RED
HWCC3 (Bag of 30)	10-15	14-16 BLUE
HWCC2 (Bag of 20)	15-30	10-12 YELLOW

NOTE: Initial supply is provided with mold power input connectors.

Smart Series® Mainframe Connector Wiring

Standard Mainframe Connector Wiring

SIDE OF MAINFRAME

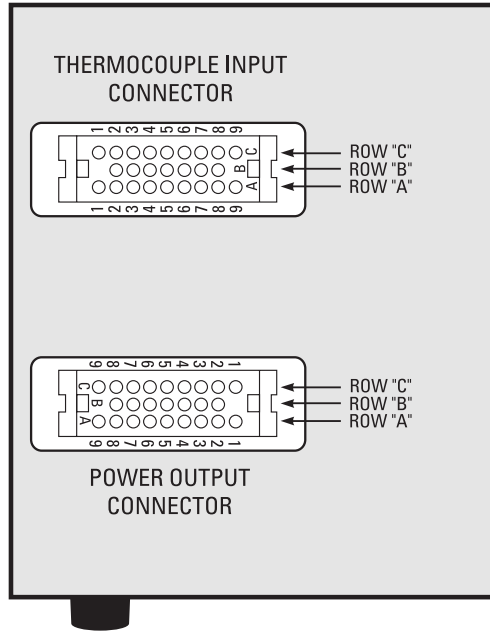

ZONE	THERMOCOUPLE INPUT
1	ROW "A" TERMINALS 1 (WHT) + 2 (RED)
2	ROW "A" TERMINALS 3 (WHT) + 4 (RED)
3	ROW "A" TERMINALS 5 (WHT) + 6 (RED)
4	ROW "A" TERMINALS 7 (WHT) + 8 (RED)
5	ROW "B" TERMINALS 2 (WHT) + 3 (RED)
6	ROW "B" TERMINALS 4 (WHT) + 5 (RED)
7	ROW "B" TERMINALS 6 (WHT) + 7 (RED)
8	ROW "C" TERMINALS 1 (WHT) + 2 (RED)
9	ROW "C" TERMINALS 3 (WHT) + 4 (RED)
10	ROW "C" TERMINALS 5 (WHT) + 6 (RED)
11	ROW "C" TERMINALS 7 (WHT) + 8 (RED)
12	ROW "A" TERM. 9 (WHT) ROW "C" TERM. 9 (RED)
ROW "B" TERMINAL 8 IS NOT USED	

ZONE	POWER OUTPUT
1	ROW "A" TERMINALS 1 + 2
2	ROW "A" TERMINALS 3 + 4
3	ROW "A" TERMINALS 5 + 6
4	ROW "A" TERMINALS 7 + 8
5	ROW "B" TERMINALS 2 + 3
6	ROW "B" TERMINALS 4 + 5
7	ROW "B" TERMINALS 6 + 7
8	ROW "C" TERMINALS 1 + 2
9	ROW "C" TERMINALS 3 + 4
10	ROW "C" TERMINALS 5 + 6
11	ROW "C" TERMINALS 7 + 8
12	ROW "A" + "C" TERMINALS 9
ROW "B" TERMINAL 8 IS NOT USED	

- NOTE:**
1. Mating cable connectors are wired the same as frame connectors shown.
 2. Wires in frames are color coded for reference when rewiring of frame connectors is necessary (see owner's manual).
 3. All grounds must be connected to ensure operator safety.

High Power Mainframe Connector Wiring

SIDE OF MAINFRAME

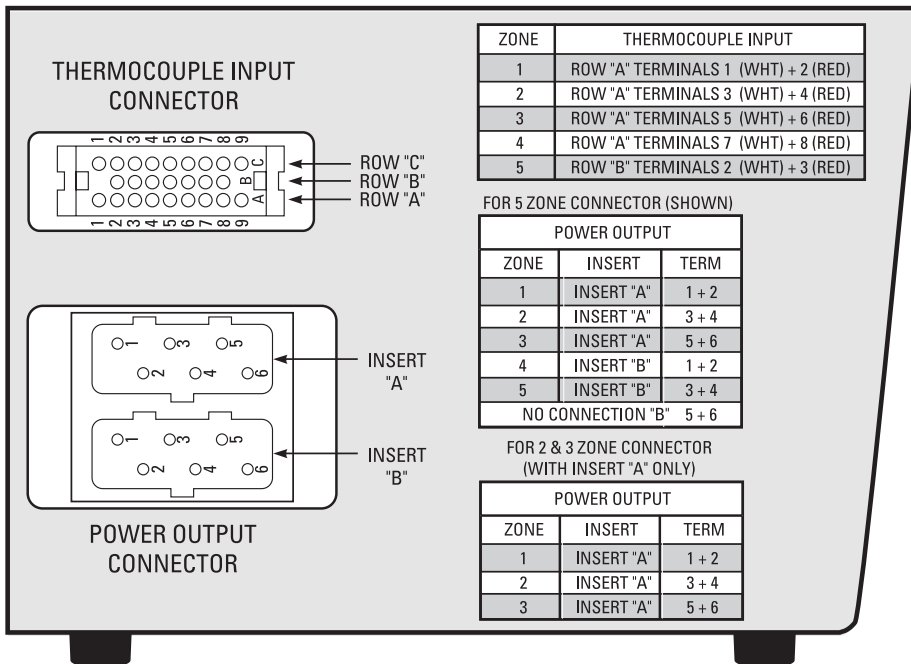

ZONE	THERMOCOUPLE INPUT
1	ROW "A" TERMINALS 1 (WHT) + 2 (RED)
2	ROW "A" TERMINALS 3 (WHT) + 4 (RED)
3	ROW "A" TERMINALS 5 (WHT) + 6 (RED)
4	ROW "A" TERMINALS 7 (WHT) + 8 (RED)
5	ROW "B" TERMINALS 2 (WHT) + 3 (RED)

FOR 5 ZONE CONNECTOR (SHOWN)

POWER OUTPUT		
ZONE	INSERT	TERM
1	INSERT "A"	1 + 2
2	INSERT "A"	3 + 4
3	INSERT "A"	5 + 6
4	INSERT "B"	1 + 2
5	INSERT "B"	3 + 4
NO CONNECTION "B" 5 + 6		

FOR 2 & 3 ZONE CONNECTOR (WITH INSERT "A" ONLY)

POWER OUTPUT		
ZONE	INSERT	TERM
1	INSERT "A"	1 + 2
2	INSERT "A"	3 + 4
3	INSERT "A"	5 + 6

Wiring Diagram for DME Hot Runner Molding System with Smart Series® Mold Connectors

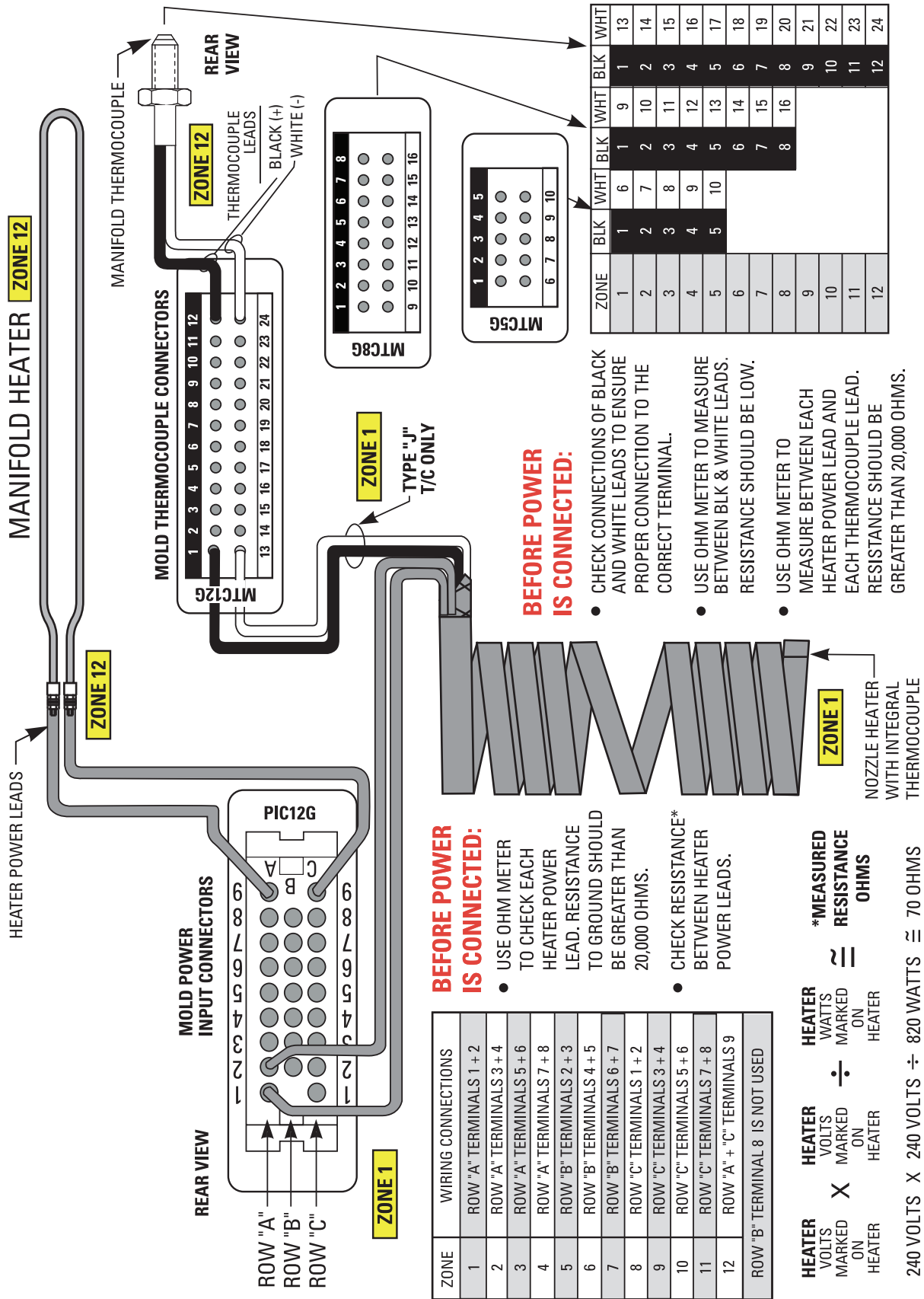

Wiring Diagram for DME Hot Runner Molding System with High Power Smart Series® Mold Connectors

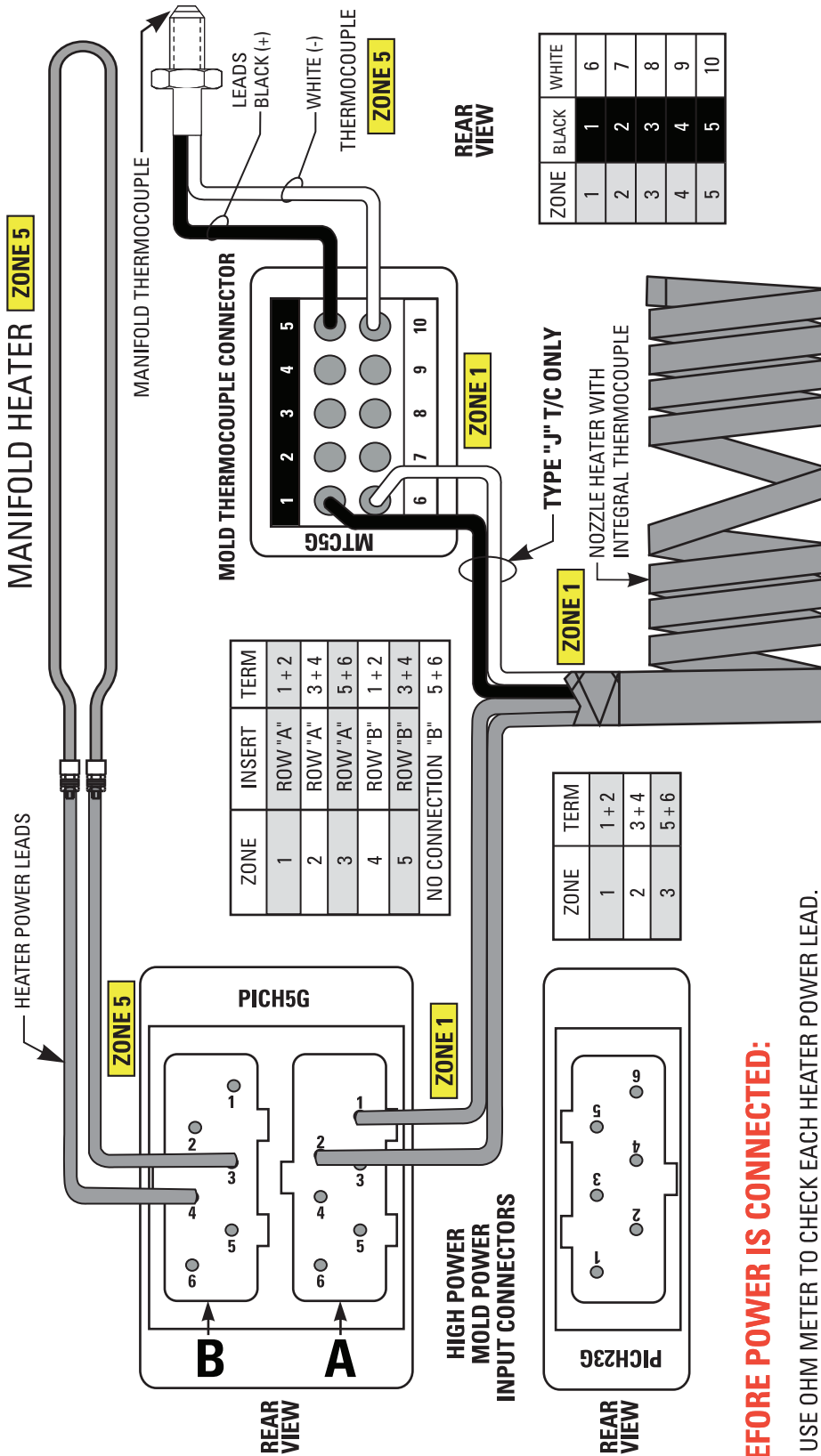

BEFORE POWER IS CONNECTED:

- CHECK CONNECTIONS OF BLACK AND WHITE LEADS TO ENSURE PROPER CONNECTION TO THE CORRECT TERMINAL.
- USE OHM METER TO MEASURE BETWEEN BLACK AND WHITE LEADS. RESISTANCE SHOULD BE LOW.
- USE OHM METER TO MEASURE BETWEEN EACH HEATER POWER LEAD AND EACH THERMOCOUPLE LEAD. RESISTANCE SHOULD BE GREATER THAN 20,000 OHMS.

BEFORE POWER IS CONNECTED:

- USE OHM METER TO CHECK EACH HEATER POWER LEAD. RESISTANCE TO GROUND SHOULD BE GREATER THAN 20,000 OHMS.
- CHECK RESISTANCE* BETWEEN HEATER POWER LEADS.

HEATER VOLTS MARKED ON HEATER	HEATER VOLTS MARKED ON HEATER	HEATER WATTS MARKED ON HEATER	*MEASURED RESISTANCE OHMS
240 VOLTS X	240 VOLTS ÷	820 WATTS ÷	≈ 70 OHMS

NOTES: All grounds must be connected to mold to ensure operator safety. All crimp connections may be eliminated. Simply remove 6" leads from PIC connectors and wire directly.

Mold Power and Thermocouple Cables

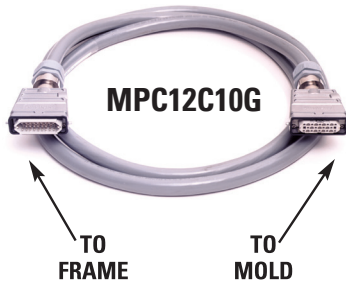

Mold Power Cables are used to connect the Mainframe to the Power Input Connector on the mold. Available in lengths of 10, 20 or 30 feet. Integral retaining latches on both the frame and mold connectors provide secure cable connections. Connector configurations ensure proper insertion of cable. Cables are wired for 5, 8 or 12 zones and 3 or 5 zones (30 AMP) for use with the appropriate Smart Series Mainframes and Mold Power Input Connectors.

Universal Mold Power Cable

The MPC12C10G, 20G or 30G Mold Power Cable also serves as a universal cable for connecting any Smart Series Mainframe to any Mold Power Input Connector. The maximum number of zones will be determined by the connector in the mold.

Mold Power Cables

10 FOOT LONG ITEM NUMBER	20 FOOT LONG ITEM NUMBER	30 FOOT LONG ITEM NUMBER	NUMBER OF ZONES (MAX.)	FOR CONNECTIONS	
				FROM FRAME (S)	TO POWER INPUT CONNECTOR
MPC5C10G	MPC5C20G	MPC5C30G	5	5, 8, 12 ZONE	PIC5G
MPC8C10G	MPC8C20G	MPC8C30G	8	8, 12 ZONE	PIC8G
MPC12C10G	MPC12C20G	MPC12C30G	12	12 ZONE	PIC12G

Mold Power Cables (30 AMP Max)

10 FOOT LONG ITEM NUMBER	20 FOOT LONG ITEM NUMBER	NUMBER OF ZONES (MAX.)	FOR CONNECTIONS	
			FROM 30 AMP FRAME (S)	TO POWER INPUT CONNECTOR
MPCH23C10G	MPCH23C20G	3	2-3 ZONE	PICH23G
MPCH5C10G	MPCH5C20G	5	5 ZONE	PICH5G

SPECIAL CABLES

Virtually any type of Conversion or Special Cable configuration can be provided by special order

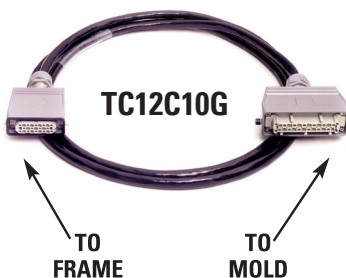

Thermocouple Cables are used to connect the Mainframe to the Thermocouple Connector on the mold, and are available in lengths of 10, 20 or 30 feet. Integral retaining latches on both the frame and mold connectors provide secure cable connections. Connector configurations ensure proper insertion of cable. Cables available are wired for 5, 8 or 12 zones for use with the appropriate Smart Series Mainframes and Thermocouple Connectors.

Thermocouple Cables (for use with 15 or 30 AMP Mainframes)

These Thermocouple Cables serve as cables for connecting dissimilar Mainframes and Thermocouple Connectors. For example, the TC8C10G could be used to connect a 12-zone frame to an 8-zone MTC8G connector. The maximum number of zones will be determined by the connector in the mold.

Thermocouple Cables

10 FOOT LONG ITEM NUMBER	20 FOOT LONG ITEM NUMBER	30 FOOT LONG ITEM NUMBER	NUMBER OF ZONES (MAX.)	FOR CONNECTIONS	
				FROM 15 AMP FRAME (S)	TO THERMOCOUPLE CONNECTOR
TC5C10G	TC5C20G	TC5C30G	5	5, 8, 12 ZONE	MTC5G
TC8C10G	TC8C20G	TC8C30G	8	8, 12 ZONE	MTC8G
TC12C10G	TC12C20G	TC12C30G	12	12 ZONE	MTC12G

* Used with all 30 AMP Mainframes.

RoHS/WEEE Compliant: Mold Power Input Connectors

For 15 AMP Applications



PIC5G



PIC8G



PIC12G

For 30 AMP Applications



PICH23G

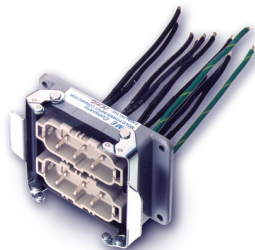

PICH5G

NOTES:
Connector PICH23G is dimensionally identical to thermocouple connector MTC8G. See next page.

For PICH23G and PICH5G, direct wiring without crimp connectors is possible by removing 6" leads.

Mold Power Input Connectors are mounted on the mold to accept power cable(s) from the Mainframe. They are supplied with six inches of numbered leads and a ground wire. All three 15 AMP connectors are the same physical size and use 14-gauge wire. Only the number of active pins change. The 30 AMP connectors are supplied with 10-gauge leads and are attached to screw terminals. Each is equipped with an integral retaining latch to provide a secure cable connection. Connector configuration ensures proper insertion of cable. Splicing of 6" leads to heater power leads is easily accomplished with the Insulated Crimp Connectors supplied.

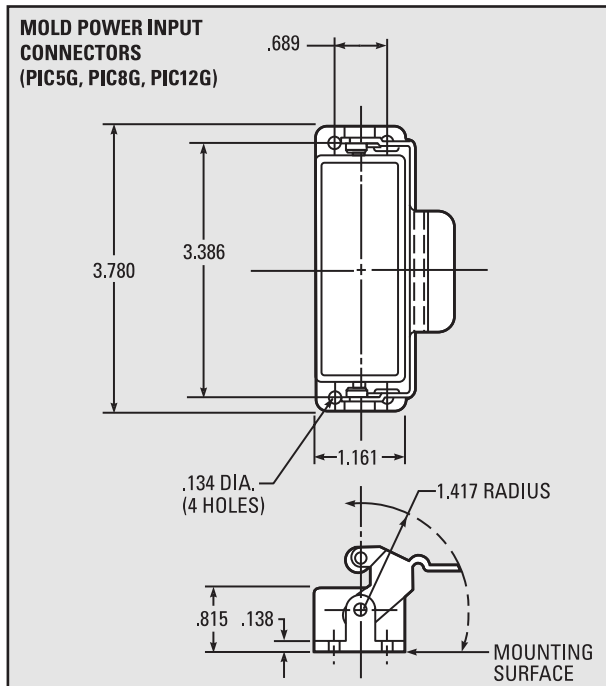

NOTE: Dimensions shown may vary slightly.

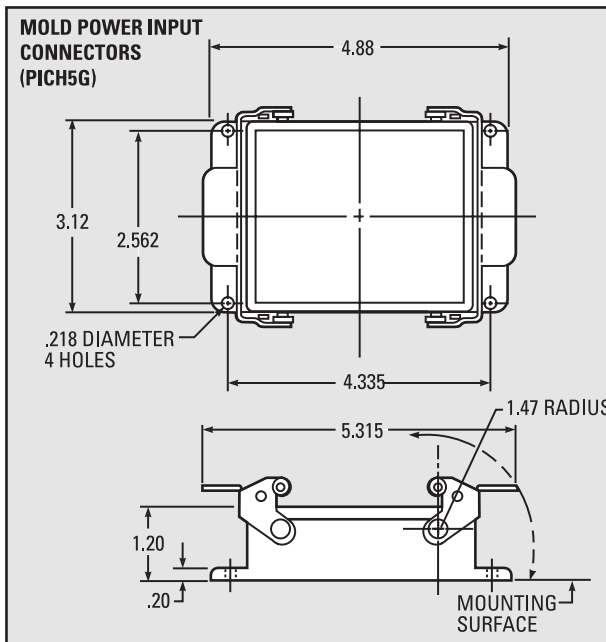

NOTE: Ground wire must be connected to mold to ensure operator safety.

Mold Power Input Connectors

ITEM NUMBER	NUMBER OF ZONES (MAX.)	AMPS (MAX.) PER ZONE
PIC5G	5	15
PIC8G	8	15
PIC12G	12	15
PICH23G	3	30
PICH5G	5	30

NOTE: Replacement parts and extraction tools can be found on page 146

Insulated Crimp Connectors

ITEM NUMBER	AMPS	FOR WIRE GAUGE
HWCC1 30 PCS.	10-15	16-22
HWCC3 30 PCS.	15	14-16
HWCC2 20 PCS.	30	10-12

NOTE: Initial supply is provided with mold power input connectors. Also, see page 126.



RoHS/WEEE Compliant: Mold Thermocouple Connectors



MTC5G



MTC8G



MTC12G

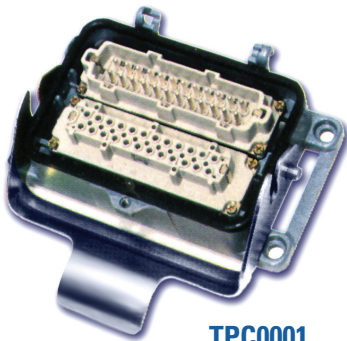

TPC0001

Thermocouple Connectors are mounted on the mold to use with thermocouple cable(s) from the Mainframe. Screw type terminals for use with iron(+) and constantan(-) thermocouple leads are numbered and coded on the side and bottom of each connector. All three connectors are equipped with integral retaining latches to provide a secure cable connection. Connector configuration ensures proper insertion of cable. Pins are made of copper alloy and are silver plated. Experience has proven that iron and constantan are not required.

ITEM NUMBER	NUMBER OF PINS	DIMENSION	
		M2	H
MTC5G	10	3.268	3.662
MTC8G	16	4.055	4.449
MTC12G	24	5.118	5.512
TPC0001	48	5.827	6.496

NOTE: MOLD POWER INPUT CONNECTOR PICH23G IS DIMENSIONALLY IDENTICAL TO MTC8G

Connectors

ITEM NUMBER	NUMBER OF ZONES (MAX.)
MTC5G*	5
MTC8G	8
MTC12G	12
TPC0001	12

* Use with 2, 3 and 5-zone, 30 AMP mainframes

**MOLD THERMOCOUPLE CONNECTOR
MTC5G
MTC8G
MTC12G**

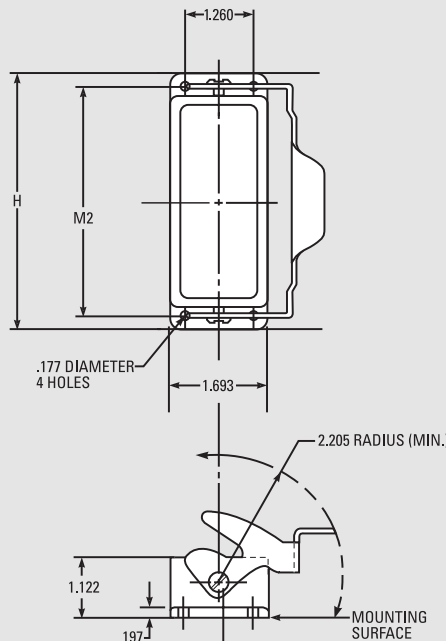

NOTE: DIMENSIONS SHOWN ARE FOR THE MTC5G, MTC8G AND MTC12G CONNECTORS

MOLD POWER AND THERMOCOUPLE CONNECTOR TPC0001

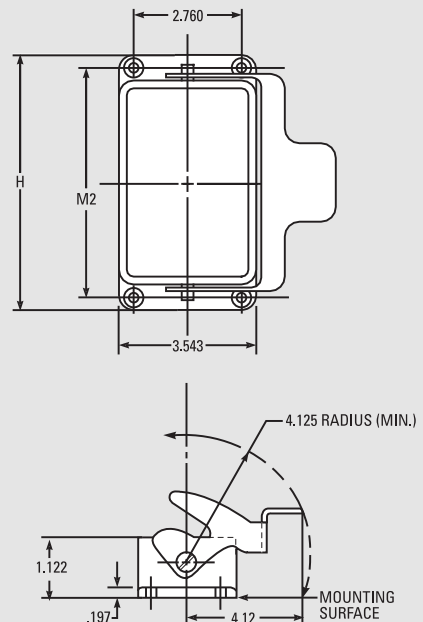

Mold Connector Pocket Layouts

NOTE: Drawing depicts below-flush mounting. Disregard dimensions marked with * for surface mounting.

Where space or mold handling and storage requirements do not permit the use of Terminal Mounting Boxes, the connectors can be below-flush or surface mounted. See drawings below and next page for dimensions.

Below-Flush and Surface Mounting of Mold Power Input Connectors (15 AMP)

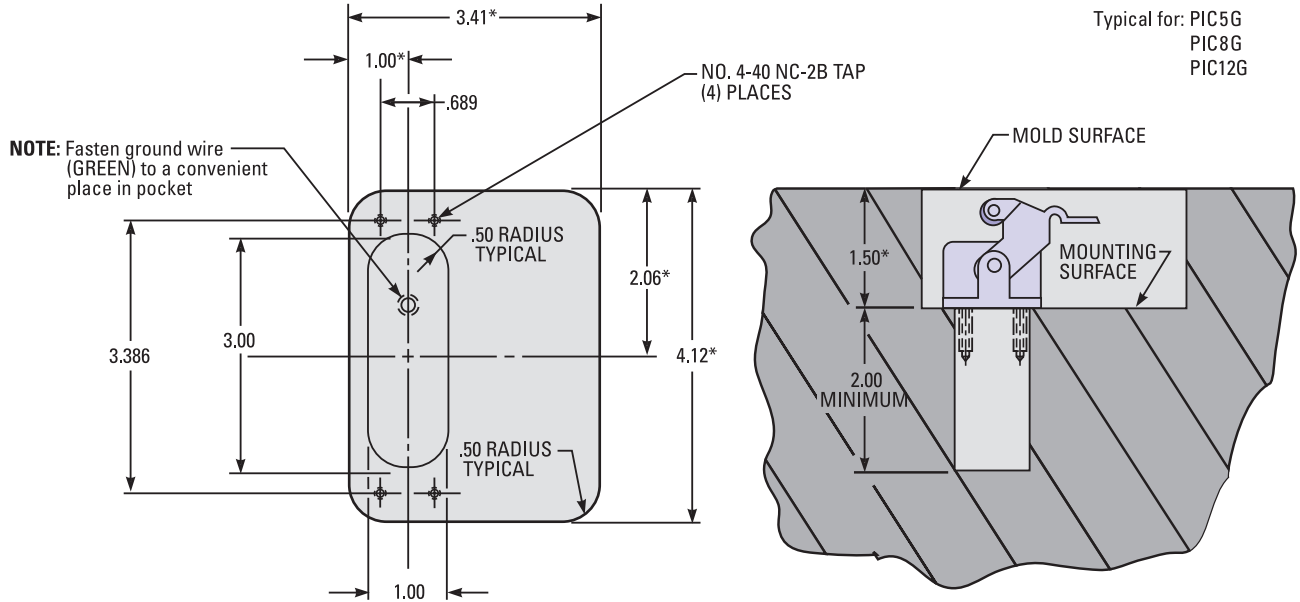

NOTE: Disregard dimensions marked with * for surface mounting.

Below-Flush and Surface Mounting of Thermocouple Connectors

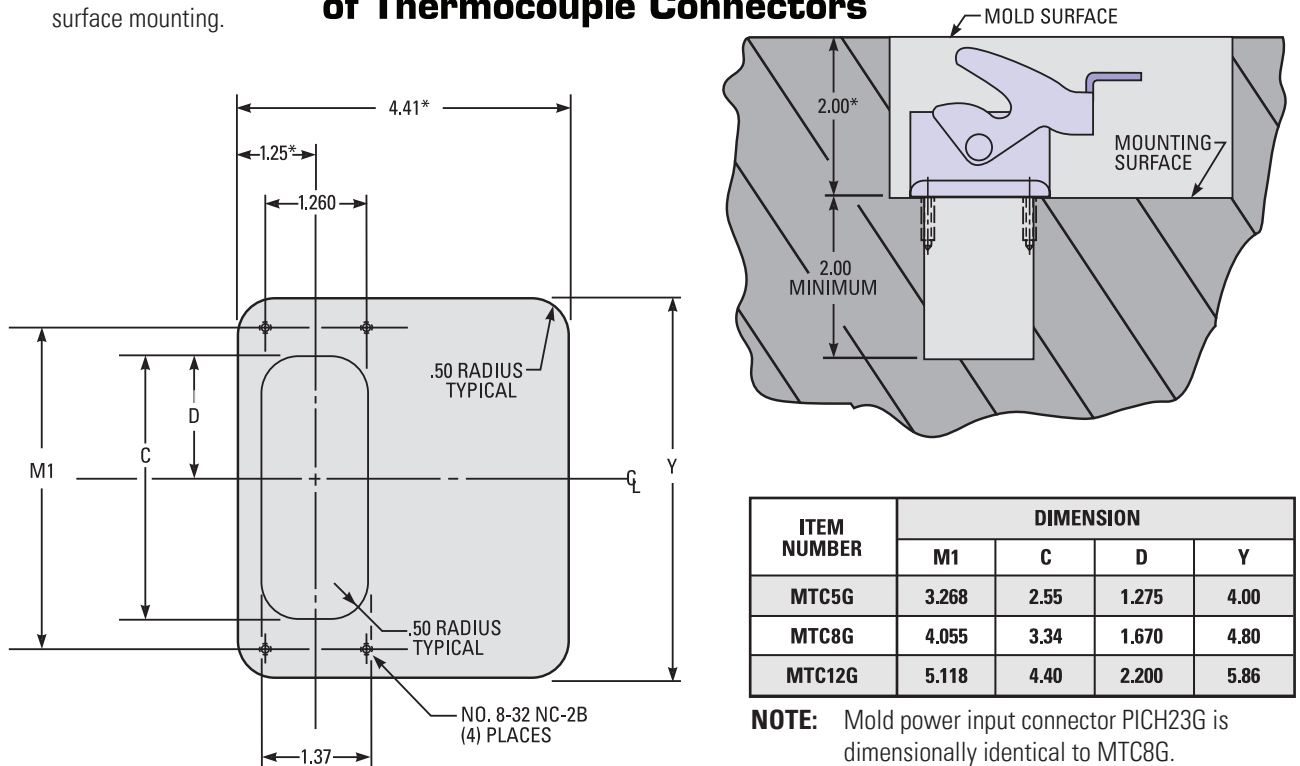

ITEM NUMBER	DIMENSION			
	M1	C	D	Y
MTC5G	3.268	2.55	1.275	4.00
MTC8G	4.055	3.34	1.670	4.80
MTC12G	5.118	4.40	2.200	5.86

NOTE: Mold power input connector PICH23G is dimensionally identical to MTC8G.

Mold Connector Pocket Layouts

Below-Flush and Surface Mounting of Mold Power Input Connectors (30 AMP)

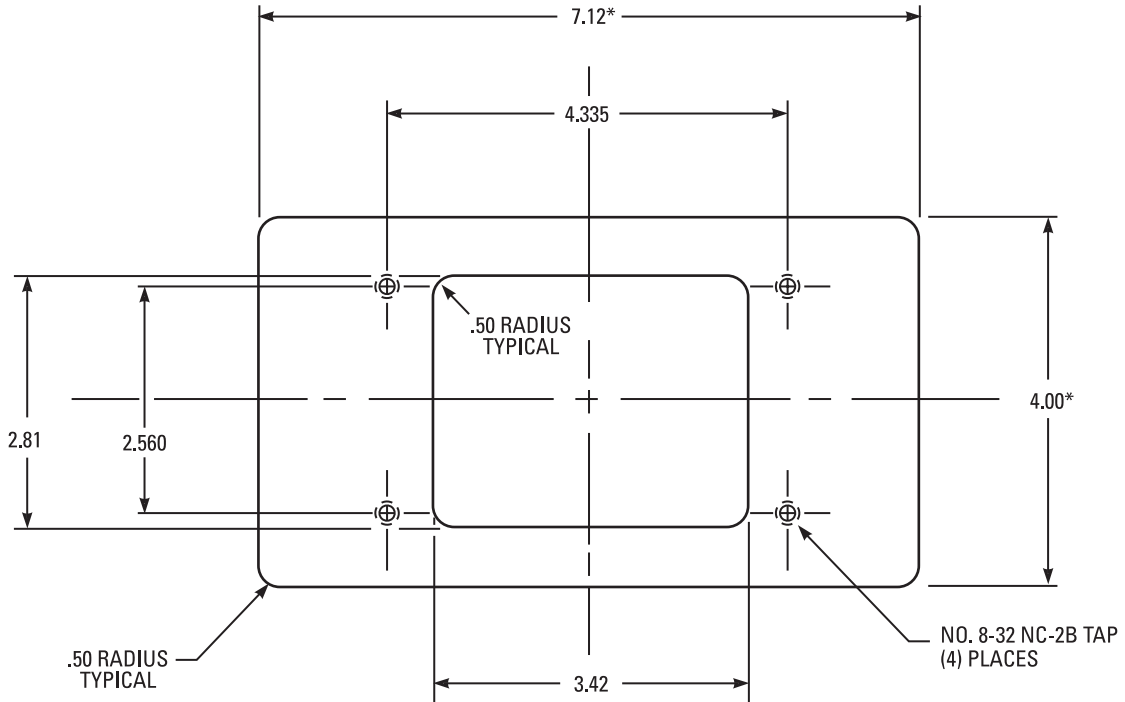

For PIC5G

NOTE: Drawing depicts below-surface mounting. Disregard dimensions marked with * for surface mounting.

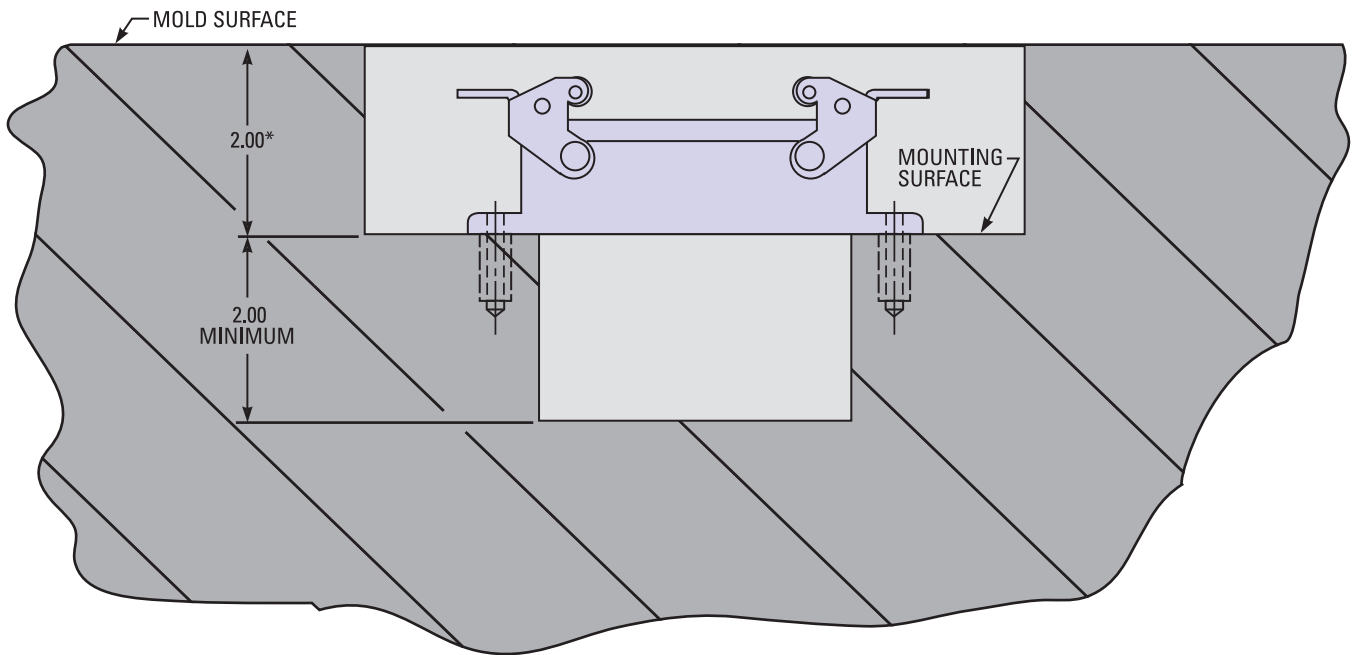

For PIC23G

(Use pocket dimensions shown on pages 131-132 as detailed for thermocouple connector MTC8G.)

RoHS/WEEE Compliant: Terminal Mounting Boxes

Pre-wired Combination Terminal Mounting Boxes

Includes terminal strip for ease of wiring, all necessary connectors installed, and power connector pre-wired to a terminal strip. All units shown without covers.



PTC5TBGTS



PTC8TBGTS

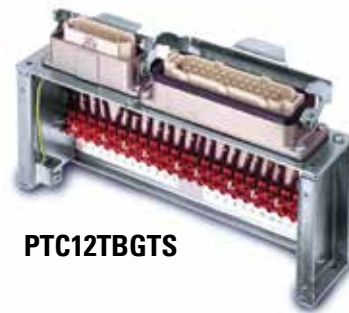

PTC12TBGTS

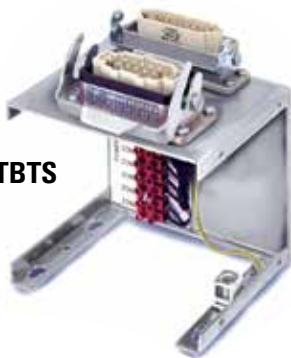

PTC5TBTS



PTC8TBTS

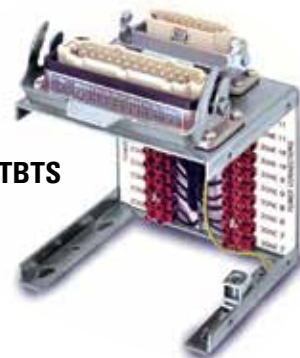

PTC12TBTS



PTC210TBGTS

PTC2TBGTS is not to be used with SSH1022, SSH1021, MFP1G, MFP1G1, MFP2G, MFPR2G controls & mainframes

Combination Terminal Mounting Boxes – with Terminal Strip

ITEM NUMBER	X	Y	H	M1	M2	ACCEPTS
PTC210TBGTS*	2.75	4.88	4.25	1.500	4.250	MPTC10/MPTC20
PTC2TBGTS*	2.75	4.88	4.25	1.500	4.250	PTC0110/PTC0120
PTC5TBGTS**	2.75	8.66	4.25	1.500	8.031	MPC5C(10 or 20)G/TC5C(10 or 20)G
PTC8TBGTS**	2.75	9.47	4.25	1.500	8.843	MPC8C(10 or 20)G/TC8C(10 or 20)G
PTC12TBGTS**	2.75	10.53	4.25	1.500	9.906	MPC12C(10 or 20)G/TC12C(10 or 20)G
PTC5TBTS**	5.00	6.13	5.12	2.625	5.000	MPC5C(10 or 20)G/TC5C(10 or 20)G
PTC8TBTS**	5.00	6.13	5.12	2.625	5.000	MPC8C(10 or 20)G/TC8C(10 or 20)G
PTC12TBTS**	5.00	6.13	5.12	2.625	5.000	MPC12C(10 or 20)G/TC12C(10 or 20)G

** Comes with all necessary connectors installed and power connector pre-wired to a terminal strip.

* Power and thermocouple connectors are pre-wired.

Terminal Mounting Boxes



PTC8TBG



PTC5TBG



PTC0012



PIC512TBG



PTC210

Terminal Mounting Boxes provide the easiest and most economical method of mounting power and thermocouple connectors on the mold. Constructed of plated heavy gauge steel, each box is pre-cut and drilled for quick mounting of the connector to the box, and box to the mold. Connector mounting hardware is supplied. Connectors are ordered separately.

Terminal Mounting Boxes for Mol Power Input Connectors

ITEM NUMBER	X*	Y	H	M1	M2	ACCEPTS
PIC512TBG	2.75	4.875	4.25	1.500	4.250	PIC5, 8 OR 12G
PICH23TBG	2.75	5.614	4.25	1.500	4.990	PICH23G
PICH5TBG	4.46	6.676	4.25	3.250	6.052	PICH5G

Terminal Mounting Boxes for Mol Power Input Connectors

ITEM NUMBER	X*	Y	H	M1	M2	ACCEPTS
MTC5TBG	2.75	4.875	4.25	1.500	4.250	MTC5G
MTC8TBG	2.75	5.614	4.25	1.500	4.990	MTC8G
MTC12TBG	2.75	6.676	4.25	1.500	6.052	MTC12G

Terminal Mounting Boxes for Mol Power Input Connectors

ITEM NUMBER	X*	Y	H	M1	M2	ACCEPTS
PTC210	2.75	4.88	4.25	1.50	4.250	(2) CKPTIC1
PTC5TBG	2.75	8.66	4.25	1.50	8.031	PIC5G, MTC5G
PTC8TBG	2.75	9.47	4.25	1.50	8.843	PIC8G, MTC8G
PTC12TBG	2.75	10.53	4.25	1.50	9.906	PIC12G, MTC12G
PTC0012	4.46	7.66	4.25	3.350	7.160	TPC0001

Terminal Mounting Boxes

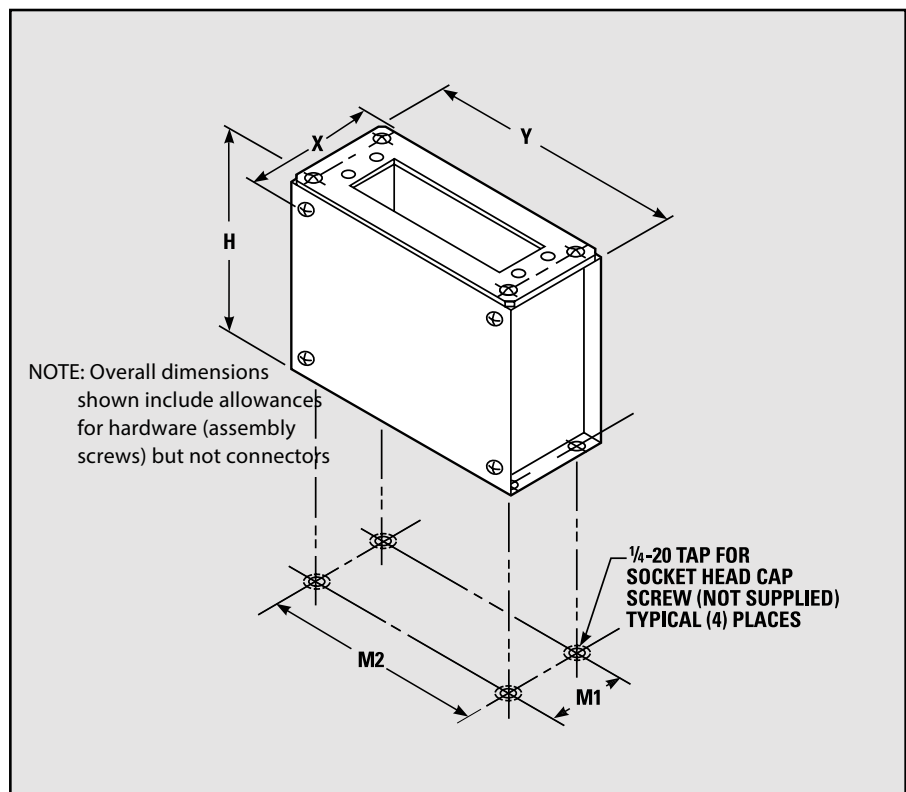

RoHS/WEEE Compliant: Microprocessor-Based Temperature Control Modules with Digital Display and Setpoint Pushwheel

COMPATIBLE WITH TAS0512

ALARM AND SYSTEM CONTROL FUNCTIONS. SEE PAGES 143-144.



SSM1512/11 (15 AMP)

The SSM1512 is the second generation of the popular SSM15G. This version maintains simplicity of operation with simultaneous display of setpoint and temperature. Other new, improved, and unique features include:

Key Features

- **Large Digital Display**
 - For easier readability of temperature, % power and faults
- **Setpoint Pushwheel**
 - For setting desired setpoint temperature
 - Allows adjustment of setpoint before turning power on
- **Auto % Power Display**
 - Shows % power output while in AUTO mode
 - Indicates average % power requirement on thermocouple failure
 - Serves as a diagnostic tool for solving hot runner system problems

Operational Refinements

- **Improved SmartStart®**
 - A more gradual temperature rise leads to a more effective heater dry-out period, thereby extending heater life
 - SmartStart® now available in MANUAL mode (optional)
- **SelectiveCycle®**
 - A very high speed power output approach
 - Enables accurate temperature control and longer heater life
- **Bumpless Transfer**
 - When a thermocouple failure occurs, operation is automatically continued with a learned % power
 - Unique software accurately assigns percent power setting
- **Third Fuse**
 - Allows for alarm output when the load fuses are blown
 - Protects module from application of excessive voltage
- **Anti-Arcing Feature**
 - Protects circuit board from damage when module is either inserted or removed under power

Switchable Options

- **Boost, Idle and Power Off Features**
 - Provides system-wide adjustment of temperatures
 - Enables alarm audio/visual output and remote alarms
 - Requires TAS0512 module and communications mainframe (See pages 148-149 for more information on these capabilities)
- **Unique AutoBoost Option**
 - Instantaneously opens frozen gates on startup
 - TAS module or mainframe communications are not required
- **Lights Out Feature**
 - After stabilizing at setpoint, display turns off; when a fault occurs, display is turned on and flashes
 - For easier detection of faults
- **Shorted Thermocouple Sensitivity Adjustment**
 - Operation can be tailored to fast or slow reaction times
 - Sensitivity can be adjusted with internal switches
 - Very useful for manifold zones with long startup times
- **Switchable °C/°F Operation**
 - Scale indicated at startup
- **K Type Thermocouple Support**
- **Cut Feature**
 - Gain cut feature for small nozzles and heaters with ungrounded internal thermocouples

RoHS/WEEE Compliant: Microprocessor-Based Temperature Control Modules with Digital Display and Setpoint Pushwheel

Warranty:

Two years
(excluding triac and fuses)

Fuse Requirements

(15 AMP only)

- (2) ABC15 fuses (Bussman only)
- (2) spare fuses included with module

SSM1512/11 (15 AMP)

MODULE ITEM NUMBER	VOLTAGE (VAC)	AMPS	WATTS
SSM1512	240	15	3600
SSM1511	120	15	1800

NOTE: Standard (240 VAC) modules are compatible with mainframes wired for either 240 VAC three phase (standard) or 240 VAC single phase.

Front Panel Controls and Indicators

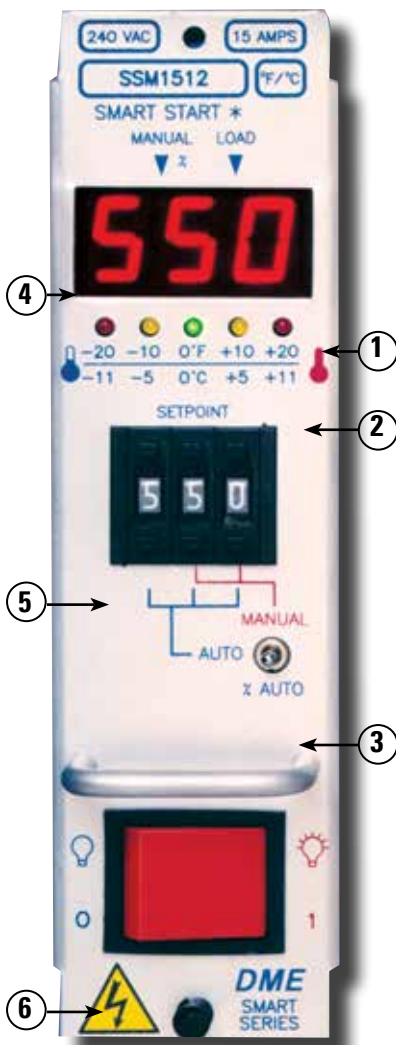

1. Process Temperature Display

Indicates process temperature, thermocouple faults and other operational modes. Displays % power when switch (3) is in “% Auto” position.

2. Temperature Deviation Lights

Indicates deviation from setpoint. Outer lights blink when temperature is more than ±40°F (22°C) from setpoint.

3. Auto/Manual/Auto % Power Switch

Selects AUTO or MANUAL control mode. Shows % power when pressed into “% AUTO” position.

4. LED Mode Indicators

Left LED illuminates during MANUAL mode. Right LED illuminates when power is supplied to heater. Right LED blinks on and off during SmartStart®.

5. Setpoint Pushwheel

Three-digit switch programs setpoint in AUTO mode. Right two digits program % power in MANUAL mode.

6. Power On/Off Switch

Controls AC power to module.

**CHECK OLDER MAINFRAMES!
CONTACT REQUIRED TO ACTIVATE CONTROLLER!**

MAINFRAME ZONE EDGE CONNECTOR (WHITE)



RPM0046 REQUIRED

Front Panel Digital LED Indicators

BACKWARD THERMOCOUPLE	SHORTED THERMOCOUPLE	OPEN THERMOCOUPLE	BUMPLESS TRANSFER	POWER OFF	STANDBY HEAT	BOOST
TEMP MODE FAHRENHEIT	TEMP MODE CENTIGRADE	PROCESS TEMP	MANUAL % POWER	FRONT PANEL LOCKOUT	LOCKOUT ERROR	

RoHS/WEEE Compliant: Microprocessor-Based Temperature Control Modules with Color Touch Screen Display



TSM-15-12

The TSM15 Smart Series Module has a color touch screen digital display providing readouts for Actual Temperature, Current Mode, Percentage Power and Current Reading. Closed-loop, fuzzy logic PID control, and auto-tuning of PID parameters provide precise control even under the most adverse processing conditions.

In the event of a thermocouple failure, the TSM can automatically invoke bumpless transfer to a percent power mode based on the last valid percentage learned before the thermocouple failure. If desired, manual bumpless transfer may be selected, in which case a thermocouple fault will turn off power to the heater until the manual percent power mode is activated by the operator.

The TSM boost level option limits boosting of the temperature by 75°C or 135°F to limit the degradation of material.

The TSM module also includes a Smart Start® mode to safely bake out damaging internal heater moisture at system start-up and to prolong heater life. Fast or slow load modes may also be selected to protect smaller heaters or compensate for “slow” loads such as externally heated manifolds. An accurate, durable and full-featured module, the TSM is fully compatible with all Smart Series or G-Series® 15 AMP mainframes.

Leak Detection capabilities (reference TSM1512 User Manual)

TSM15 SmartSeries® Controller with Default Settings (Factory Settings)

Zone temperature	260°C or 500°F
Standby level	100°C or 180°F
Boost level	75°C or 135°F
Over temperature range	10°C or 18°F
Under temperature range	
Ramp	On
Auto-Manual	On
Extended alarms for Manual, Standby and Boost	Off

Front Panel Controls and Indicators



- ← ① Actual temperature (and scale)
- ← ② Current mode shows set-point
- ← ③ Percentage power applied
- ← ④ Current reading

When reconfiguring your controller for a new tool or environment, this chapter of the manual shows how to alter controller default settings to your preferred values and afterward to save them.

Should anything seem wrong with your new settings then it is possible to restore the default settings at any time.

MAINFRAME ZONE EDGE CONNECTOR (WHITE)



RPM0046 REQUIRED

CHECK OLDER MAINFRAMES! CONTACT REQUIRED TO ACTIVATE CONTROLLER!

RoHS/WEEE Compliant: Microprocessor-Based Temperature Control Modules with Color Touch Screen Display

Individual Card Diagnostics

The control system has several features which provide a diagnosis of faults in the control system, the tool heaters and thermocouple sensors.

If a zone temperature is seen to deviate from the actual setting beyond the alarm limits then the display will change to White text in Red box and generate a remote alarm.

The following is a list of alarm conditions that may be detected and which will also activate the output contacts.

ERROR MESSAGE	CAUSE	ACTION
ERR!	Little or no temperature rise has been detected in that zone. When the console starts to apply power it expects to see an equivalent heat rise at the thermocouple. If the thermocouple has been trapped and pinched elsewhere in the tool or cable then it cannot sense the full heat rise that occurs at the tip. If left uncorrected, there is a danger that the zone could overheat and damage the tip. Instead the circuit maintains the output at whatever level it reached when the monitor circuit detected the fault.	Check thermocouple wiring; it may be reversed. Heater wiring may be faulty or element may be open circuit.
FUSE	The output fuse for that zone has failed. Please note: A fuse can only fail due to a fault external to the controller. Identify and rectify the fault before replacing the fuse. Note: The fuse detection circuit requires a continuous low level current through a high impedance bleed resistor to maintain the alarm condition. As a result the load circuit is still connected to the main's voltage supply and it is not safe to attempt to repair or replace the fuse without first isolating the circuit. If the fuse in question is mounted on a control card then it is safe to unplug the board in order to isolate the circuit and replace the fuse on the card.	Replace the fuse with one of the same rating and type; i.e. High Rupture Current load fuse. The blown fuse is located on the control card.
GND	The system has detected an ground fault.	Check your heater wiring for a low impedance path to the ground.
LINE	No mains supply synchronization pulses being received. The 3-phase supply is used in a cross-over detection circuit to generate timing pulses for accurate phase control and firing the triac. If the phase detection fails on one or two phases then there is no pulse to use to measure phase angle and the LINE error message is generated. Meanwhile, all circuits on the healthy phases will continue to work normally.	There is a phase detection circuit on each TMS15-Series card and a common phase detection circuit on all other controller types. Although a fault in such circuits may cause the LINE error message, such fault is very rarely seen. The most common error is either the absence of one phase or, if a plug has been re-wired incorrectly, a swapped phase and neutral. If a LINE error message occurs then switch off and isolate the controller then check supply wiring for presence of all three phases.
REV	The card has detected an abnormal input at the T/C termination that indicates a shorted or reversed thermocouple.	If the REV alarm persists, switch off the controller and investigate the offending zone.
T/C	An open circuit thermocouple has been detected and no auto-response has been selected in the T/C Open Error column of the Setup page.	For immediate recovery, change to open loop control. Make a note of the above action so that when the controller is free you can check to see whether the input fuse on the control card has ruptured. If the fuse is good then you may need to check the wiring for faults or even replace the thermocouple.

Temperature Alarm/System Control Modules

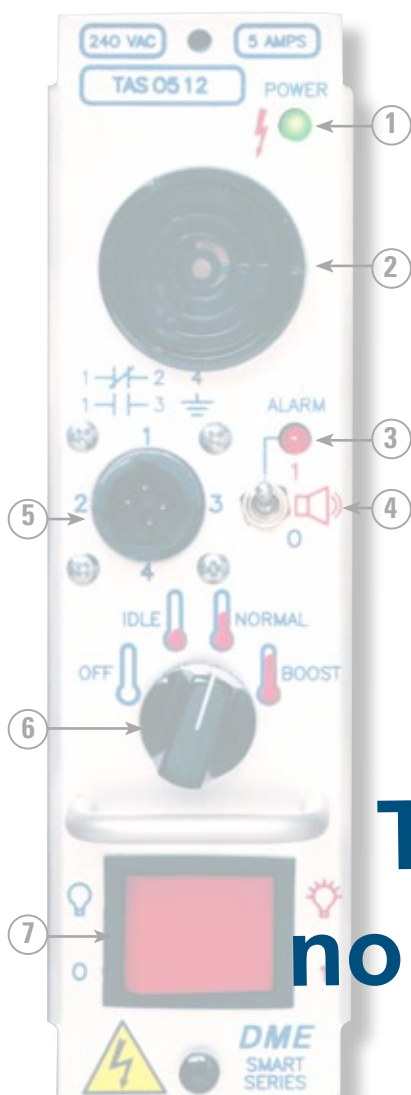

TAS0512/11 Temperature Alarm Function

- Provides alarm for over or under temperature, or diagnostic error
- Provides visual and audible indications of an alarm
- The audible alarm (2) can be turned on or off with switch (4)
- Relay contacts (5) are provided to allow hook-up of remote equipment such as a light, a conveyor or a machine function
- Relay contacts are unaffected by the position switch (4)
- An infinite number of zones of control can be monitored as long as they are contained within the same communications-style mainframe as the TAS module

System Control Functions

Up to 63 zones can be controlled remotely at one time. These zones must be contained within the same communications-style mainframe as the TAS module.

NORMAL / IDLE

- Rotary switch (6) provides remote control of DSS1502/01, DSS1512/11, CSS1502/01, SSM1502/01, and SSM1512/11
- Control modules can all be commanded to respond from NORMAL to IDLE (Standby Heat)
- In IDLE, the modules will adjust to a setting of 93°C (200°F)

Exceptions: SSM1502/01 and SSM1512/11 adjust to a setting of 100°C (212°F)

- Moving a rotary switch from NORMAL to IDLE causes all zones to return to their established setpoints
- The user can set IDLE for temporary lowering of all zones to prevent material degradation
- This feature can be used to keep heaters warm enough to prevent absorption of moisture

BOOST / OFF

- The SSM1502/01 and SSM1512/11 can be placed into BOOST and OFF
- BOOST will raise the setpoint of the module by 10, 20, or 30%
- OFF shuts off power to the heater but allows the user to monitor cool down of the hot runner system
- Each SSM1502/01 and SSM1512/11 can be individually programmed to respond to OFF, IDLE and BOOST commands
- The user can quickly drive all nozzle zones into BOOST to open frozen gates

Front Panel Controls and Indicators

- 1. Power On Indicator:** LED illuminates when power is applied to the module.
- 2. Audible Alarm:** Emits a loud audible alarm when the alarm switch (4) is placed in the "1" position (ON) and an alarm condition is sent by a compatible control module.
- 3. Alarm Indicator:** LED illuminates when an alarm condition is sent by a compatible module.
- 4. Audio Alarm On/Off Switch:** Turns the audio alarm (2) on or off.
- 5. Alarm Relay Connector** Provides relay contacts for use with remote equipment. Mating connector is supplied.
- 6. System Control Switch:** Activates the OFF, IDLE and BOOST mode in all compatible modules.
- 7. Power On/Off Switch:** Controls AC power to the module.

This product is no longer available

Temperature Alarm/System Control Modules

ITEM NUMBER	VOLTS
TAS0512	240 VAC
TAS0511	120 VAC

NOTE: Standard (240 VAC) modules are compatible with mainframes wired for either 240 VAC three-phase (standard) or 240 VAC single-phase. Use TAS0511 for 120 VAC operation.

FUSE REQUIREMENTS: (2) ABC1 fuses. **NOTE:** (2) spare fuses included with module.

WARRANTY: Two years (excluding fuses).

TAS Module Compatibility

NOTE:

TAS module is not compatible with older CSS15G/30G or DSS15G/30G modules.

MODULE	FUNCTIONS			
	ALARM	IDLE	BOOST	OFF
SSM1502/01/12/11	✓	✓	✓	✓
SSM3002/12	✓	✓	✓	✓
TSM1512	✓	✓	✓	✓

MODULE	FUNCTIONS			
	ALARM	IDLE	BOOST	OFF
CSS1502/01	✓	✓		
CSS3002	✓	✓		
SSM15G	✓			
SSM15G1	✓			
SSM30G	✓			

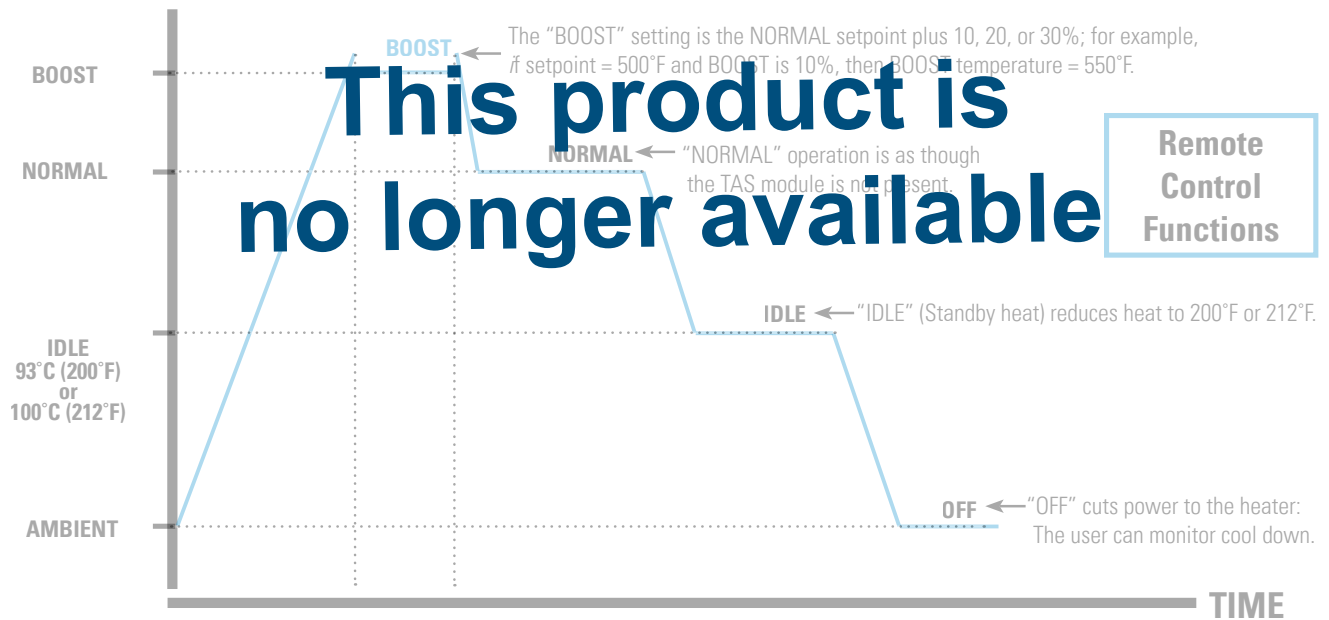

Upgrade Kits For Converting to Communications Mainframes

ITEM NUMBER	MAIN FRAME	ITEM NUMBER	MAIN FRAME
CIK4	4-ZONE	CIK28	28-ZONE
CIK5	5-ZONE	CIK32	32-ZONE
CIK7	7-ZONE	CIK36	36-ZONE
CIK8	8-ZONE	CIK40	40-ZONE
CIK11	11-ZONE	CIK44	44-ZONE
CIK12	12-ZONE	CIK48	48-ZONE
CIK16	16-ZONE	CIK2HP	2-ZONE HIGH POWER
CIK20	20-ZONE	CIK3HP	3-ZONE HIGH POWER
CIK24	24-ZONE	CIK5HP	5-ZONE HIGH POWER

Replacement Parts and Service Items for DME Smart Series® Temperature Control Systems

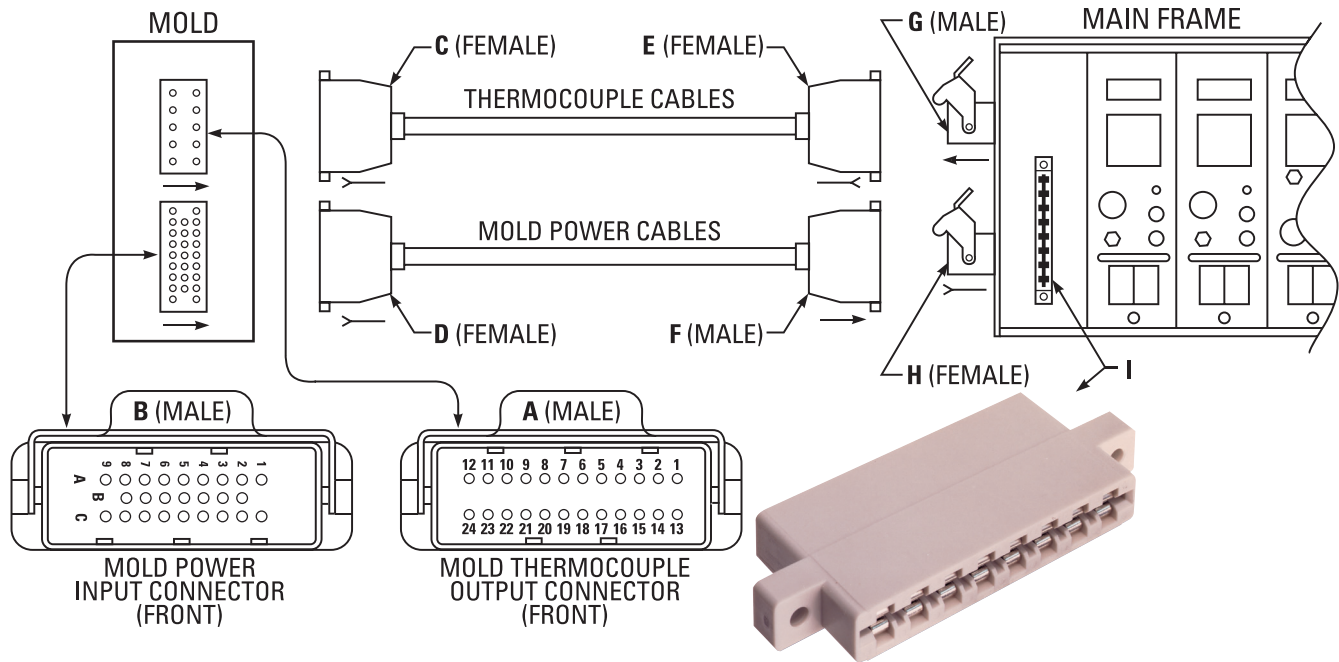

NOTE: For upper inside communications connectors, see previous page.

Connectors / Connector Kits (5-48 zone, 15 Amp; 2-5 zone, 30 Amp)

REFERENCE LETTER	DESCRIPTION	ITEM NUMBER
A	Mold Thermocouple Output Connector	see page 132
B	Mold Power Input Connector	see page 131
C	Mold End Kit for 5-Zone Thermocouple Cable (10, 15 or 30 AMP)	CKTF15G
	Mold End Kit for 8-Zone Thermocouple Cable (10, 15 or 30 AMP)	CKTF18G
	Mold End Kit for 12-Zone Thermocouple Cable (10, 15 or 30 AMP)	CKTF112G
D	Mold End Kit for all 10 or 15 AMP Power Cables	CKPF112BG
	Mold End Kit for all 2 or 3-Zone 30 AMP Power Cables	CKPF13CG
	Mold End Kit for all 5-Zone 30 AMP Power Cables	CKPF15CG
E	Frame End Kit for all Thermocouple Cables (10, 15 or 30 AMP)	CKTF112AG
F	Frame End Kit for all 10 or 15 AMP Power Cables	CKPM112BG
	Frame End Kit for 2 or 3-Zone 30 AMP Power Cables	CKPM13CG
	Frame End Kit for all 5-Zone 30 AMP Power Cables	CKPM15CG
G	Thermocouple Input Kit for all Mainframes (10, 15 or 30 AMP)	CKTM212AG
H	Power Output Kit for all 10 or 15 AMP Mainframe	CKPF212BG
	Power Output for all 2 or 3-Zone 30 AMP Mainframe	CKPF32CG
	Power Output Kit for all 5-Zone 30 AMP Mainframe	CKPF25CG
I	Edge Card Connector Kit for all Mainframe PC Boards (10, 15 or 30 AMP)	CKF312G

Replacement Parts and Service Items for DME Smart Series® Temperature Control Systems

Mainframe, Cable Components, and Service Tools*

CBD10M	10 AMP 2 POLE, CIRCUIT BREAKER USED IN MFP1G AND MFP1G1	
CBD20M	20 AMP 2 POLE, CIRCUIT BREAKER USED IN MFR2G	
CBD30M	30 AMP 2 POLE, CIRCUIT BREAKER USED IN MFFPR2G AND MFHP1G	
CBD50	50 AMP 3 POLE, CIRCUIT BREAKER USED IN 5 THROUGH 12 ZONE MAINFRAMES	
CBD70	70 AMP 3 POLE, CIRCUIT BREAKER USED IN 16 THROUGH 48 ZONE & HIGH POWER MAINFRAMES	
PIN0114	14 GAUGE MALE PIN FOR "B" & "F" POWER CONNECTORS (PACKAGE OF 30)	SEE PREVIOUS PAGE
PIN0214	14 GAUGE FEMALE SOCKET FOR "D" & "H" POWER CONNECTORS (PACKAGE OF 30)	SEE PREVIOUS PAGE
PIN0120	20 GAUGE MALE PIN FOR "G" THERMOCOUPLE CONNECTOR (PACKAGE OF 30)	SEE PREVIOUS PAGE
PIN0220	20 GAUGE FEMALE PIN FOR "E" THERMOCOUPLE CONNECTOR (PACKAGE OF 30)	SEE PREVIOUS PAGE
RPM0048	EXTRACTION TOOL FOR ALL PIN-TYPE CONNECTOR PINS	
RPM0038	NEON INDICATORS USED ON 240 VAC MAINFRAME CIRCUIT BREAKER PANELS	
RPM0044	CARD GUIDES FOR ALL MAINFRAMES	
RPM0046	PINS FOR WHITE EDGE CARD CONNECTORS "I" (PACKAGE OF 20)	
RPM0059	PANEL MOUNT BASE & LATCH FOR 5-ZONE THERMOCOUPLE MOLD CONNECTION "A"	SEE PREVIOUS PAGE
RPM0060	PANEL MOUNT BASE & LATCH FOR 8-ZONE THERMOCOUPLE MOLD CONNECTION "A"	SEE PREVIOUS PAGE
RPM0061	PANEL MOUNT BASE & LATCH FOR 12-ZONE THERMOCOUPLE MOLD CONNECTION "A"	SEE PREVIOUS PAGE
RPM0062	MALE INSERT FOR 5 ZONE THERMOCOUPLE MOLD CONNECTION "A"	SEE PREVIOUS PAGE
RPM0063	MALE INSERT FOR 8-ZONE THERMOCOUPLE MOLD CONNECTION "A"	SEE PREVIOUS PAGE
RPM0064	MALE INSERT FOR 12-ZONE THERMOCOUPLE MOLD CONNECTION "A"	SEE PREVIOUS PAGE
RPM0065	FEMALE INSERT FOR 5-ZONE THERMOCOUPLE CABLE CONNECTOR "C"	SEE PREVIOUS PAGE
RPM0066	FEMALE INSERT FOR 8-ZONE THERMOCOUPLE CABLE CONNECTOR "C"	SEE PREVIOUS PAGE
RPM0067	FEMALE INSERT FOR 12-ZONE THERMOCOUPLE CABLE CONNECTOR "C"	SEE PREVIOUS PAGE
RPM0068	HOOD FOR 5 ZONE THERMOCOUPLE CABLE CONNECTOR "C"	SEE PREVIOUS PAGE
RPM0069	HOOD FOR 8 ZONE THERMOCOUPLE CABLE CONNECTOR "C"	SEE PREVIOUS PAGE
RPM0070	HOOD FOR 12 ZONE THERMOCOUPLE CABLE CONNECTOR "C"	SEE PREVIOUS PAGE
RPM0071	HOOD FOR 5, 8 & 12 POWER & THERMOCOUPLE CABLE CONNECTIONS "D", "E" & "F"	SEE PREVIOUS PAGE
RPM0072	MALE INSERT FOR "B", "F" & "G" (15 AMP CONNECTOR RATING IS EXCLUSIVE TO DME)	SEE PREVIOUS PAGE
RPM0073	FEMALE INSERT FOR "D", "E" & "H" (15 AMP CONNECTOR RATING IS EXCLUSIVE TO DME)	SEE PREVIOUS PAGE

*(Reference page 134-147 for Letter Designations)

All Smart Series Modules

ABC1	1 AMP 250 VAC FUSE
ABC3	3 AMP 250 VAC FUSE - NOTE: THESE LOWER POWER FUSES ARE RECOMMENDED FOR NOZZLES
ABC5	5 AMP 250 VAC FUSE - NOTE: THESE LOWER POWER FUSES ARE RECOMMENDED FOR NOZZLES
ABC10	10 AMP 250 VAC FUSE - NOTE: REQUIRED FOR 15 AMP MODULES USED IN 10 AMP FRAMES
ABC15	15 AMP 250 VAC FUSE
RPM0123	15 AMP 250 VAC FUSE - ULTRAFast
RPM0124	.062 AMP TC FUSE FOR TSM MODULES ONLY
NYL0001	"NYLATCH" MODULE RETENTION PLUNGER AND GROMMET (10/PKG) - NOTE: AT THE BOTTOM OF EACH MODULE
RPM0008	POWER ROCKER SWITCH FOR ALL MODULES EXCEPT DSS AND CSS1524
RPM0009	TRANSFORMER TYPE DST416 FOR ALL MODULES EXCEPT DSS & TAS
RPM0027	ALUMINUM HANDLE FOR 15 AMP MODULES
RPM0039	30 AMP 2 POLE, CIRCUIT BREAKER FOR MODULES
RPM0023	TRIAC - TYPE Q6040P 40 AMP 600 VOLT FOR USE ON ALL MODULES
RPM0054	TRIAC - TYPE BTA40800B 40 AMP 800 VOLT FOR USE ON ALL MODULES EXCEPT CSS
RPM0050	2200 OHM FLAME PROOF FUSIBLE LINK RESISTOR USED IN THERMOCOUPLE CIRCUIT (10/PK) USED ON ALL MODULES
RPM0088	A/D CONVERTER FOR SSM15G, SSM15G1, SSM30G, SSH1001, SSH-1002 AND ALL CSS MODULES

U.S. 800-626-6653 ▪ Canada 800-387-6600 ▪ dme.net ▪ store.dme.net

Replacement Parts and Service Items for DME Smart Series® Temperature Control Systems

SSM15G, SSM30G, SSH1002, ESH1012

RPM0010	TRIAC DRIVER U5
RPM0012	OPTOCOUPLER U6 & U7
RPM0013	OPERATIONAL AMPLIFIER U2
RPM0014	OPERATIONAL AMPLIFIER U8
RPM0015	SETPOINT POTENTIOMETER (FRONT PANEL)

CSS15G, CSS30G, CSS1502, CSS3002

CSS0001	MICROPROCESSOR FOR CSS15G
CSS0002	MICROPROCESSOR FOR CSS1502
RPM0011	TRIAC DRIVER U14
RPM0012	OPTOCOUPLER U9 & U11
RPM0013	OPERATIONAL AMPLIFIER U8 & U13
RPM0014	OPERATIONAL AMPLIFIER U3

**These products are
no longer available**

SSM1501, SSM1502, SSM3002, SSH1011, SSH1012, ESH1012

SSM0002	MICROPROCESSOR
RPM0010	TRIAC DRIVER U5
RPM0014	OPERATIONAL AMPLIFIER U3 & U8
RPM0053	PUSHWHEEL ASSEMBLY, WITH CABLE
RPM0055	AUTO/MANUAL/AUTO% SWITCH FOR FRONT PANEL (SSM ONLY) (FRONT PANEL)
RPM0056	AUTO/MANUAL/AUTO% SWITCH FOR FRONT PANEL (SSH & ESH) (FRONT PANEL)
RPM0087	250 MA TIME LAG FUSE F3; CHECK YOUR MODULE!
RPM0090	160 MA TIME LAG FUSE F3; CHECK YOUR MODULE!

TAS0501, TAS0502, TAS0511, TAS0512

RPM0025	BEEPER
RPM0026	TRANSFORMER
RPM0028	SWITCH STANDBY HEAT (TAS0501, TAS0502, ONLY) & ALARM (ALL UNITS) (FRONT PANEL)
RPM0057	ROTARY SWITCH FOR OFF, STANDBY HEAT, NORMAL, BOOST (TAS0511, TAS0512, ONLY)
RPM0058	KNOB FOR RPM0057
RPM0029	RECEPTACLE CONNECTOR FOR FRONT PANEL
RPM0030	MATING CONNECTOR (PLUG) FOR RPM0029
RPM0031	PINS FOR RPM0030
RPM0032	SOCKETS FOR RPM0029
RPM0033	RELAY #1 - ALARM OUTPUT CONNECTOR
RPM0034	RELAY #2 - BEEPER CONTACTS

Input Power Wiring Diagrams (Option A)

The diagrams on pages 148 through 150 are printed on the back panels of the mainframes. For your convenience, they are depicted here along with additional information.

For information on input wiring for 30 AMP mainframes, contact DME.

Standard input wiring for mainframes, unless specified otherwise at time of order, is 240 VAC, three-phase, 4-wire, 50/60 Hz. (OPTION A). If it becomes necessary to change to another configuration, refer to the appropriate diagram and information on the following pages:

Page 148: (OPTION A) 208-240 VAC, 3-phase, 4-wire

Page 149: (OPTION B) 380-415 VAC, 3-phase, 5-wire

Page 150: (OPTION C) 240 VAC, 2-phase, 4-wire

(OPTION D) 208-240 VAC, single phase, 3-wire 120 VAC, 2-phase, 4-wire

NOTE: For mold power and thermocouple connector wiring information, see pages 128-129.

OPTION A (Standard) 208 – 240 VAC, Three-Phase, 4-Wire Delta or “Y” Power Distribution System

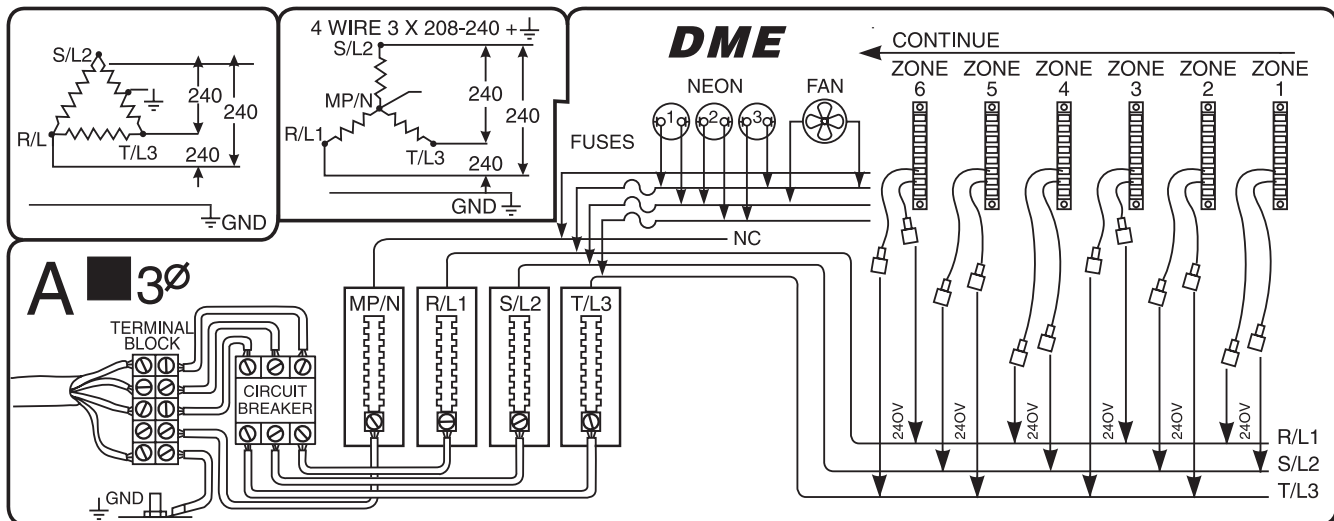

As shown above, each module is powered from one of the three phases. Zone (1), for example, is powered from Phase 1, which is supplied by R/L1 and S/L2. Zone (2) is powered by Phase 2, which is supplied by S/L2 and T/L3. Zone (3) is powered by Phase 3, which is supplied by R/L1 and T/L3.

NOTE: At this point, the sequence repeats itself. For example, Zone (4) is connected the same as Zone (1) to R/L1 and S/L2 and Zone (5) is connected the same as Zone (2) to S/L2 and T/L3 and Zone (6) is connected the same as Zone (3) to R/L1 and T/L3. Zone (7) is then connected to the same phase as Zone (1) and (4), etc. This method of connection assures the greatest likelihood of line balance.

Input Power Wiring Diagrams (Option B)

OPTION B 380 – 415 VAC, Three-Phase, 5-Wire "Y" Power Distribution System

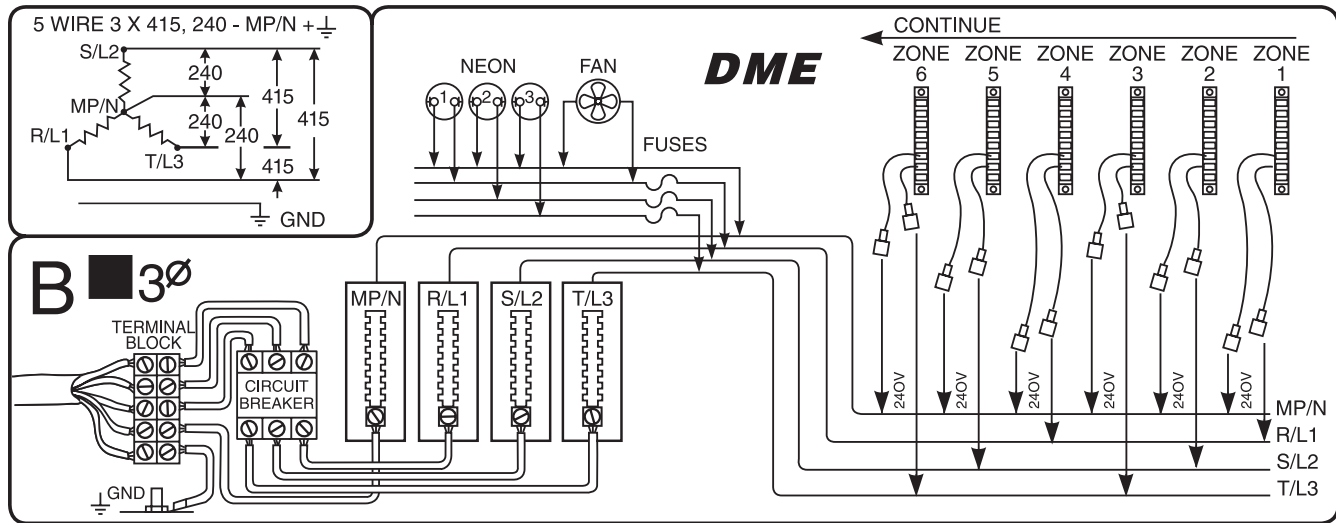

CAUTION NOTE: The voltages from line-to-line in this system are 380 to 415 volts. Severe damage to module and mainframe could result if this type of AC input system is connected to a mainframe wired as OPTION A. This type of power distribution is not found or is very uncommon in the United States but is the most common system found in many other countries worldwide.

WARNING: If export of this system is intended, make sure that wiring is reconfigured for the country where it is to be used.

Please note that the 380-415 Volt Power Distribution System is the same as the "Y" connection shown in OPTION A except for the voltage levels and the use of the MP/N to develop the 240 volt from the 380-415 volt system. Notice that all modules have one line connected to MP/N and the other side connected to one of the three phase lines.

Example: Zone (1) is connected to Phase 1, which is supplied by R/L1 and MP/N.
Zone (2) is connected to Phase 2, which is supplied by S/L2 and MP/N.
Zone (3) is connected to Phase 3, which is supplied by T/L3 and MP/N.
Zone (4) starts the sequence over again. It is connected to Phase 1 R/L1 and MP/N, etc.

Input Power Wiring Diagrams (Options C and D)

Example: Zone (1) is connected to MP/N and R/L1. Zone (2) is connected to MP/N and S/L2, etc. Zone (3) starts the sequence over again. It is connected to MP/N and R/L2, same as zone (1).

OPTION C 240 VAC, Two-Phase, 4-Wire

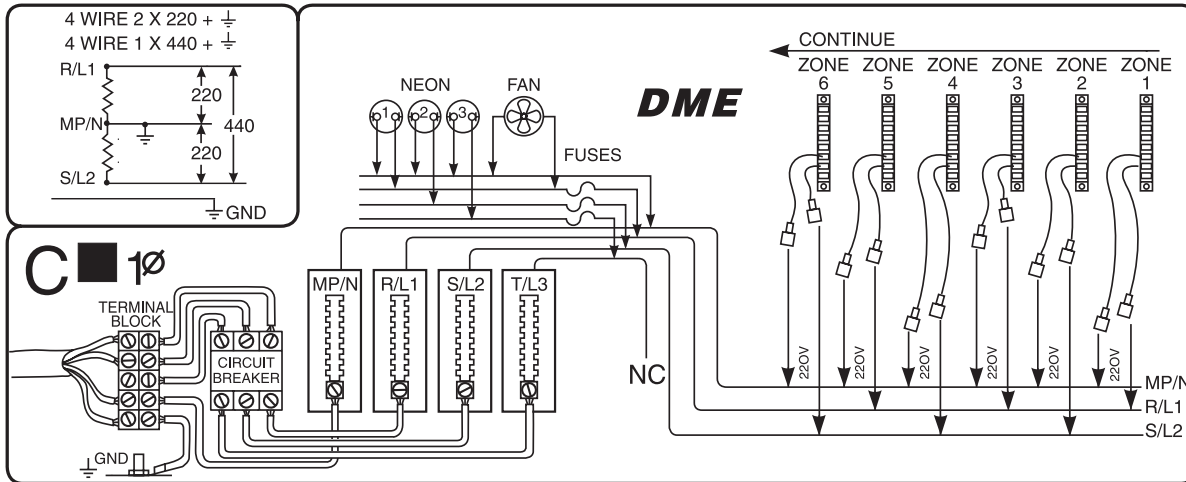

The 240 volt single-phase connection only uses two power lines plus ground.

CAUTION: Only power conductors should be connected through the circuit breaker. Never make ground connections through a circuit breaker. Notice that the output of the circuit breaker is connected to terminal strips R/L1 and S/L2. Also notice that ground is common with MP/N in this system. All zones in this system have to be connected to MP/N and either R/L1 or S/L2. Line balance is achieved by alternating between R/L1 and S/L2.

OPTION D 208 – 240 VAC, Single-Phase, 3-Wire or 120 VAC, Two-Phase, 4-Wire

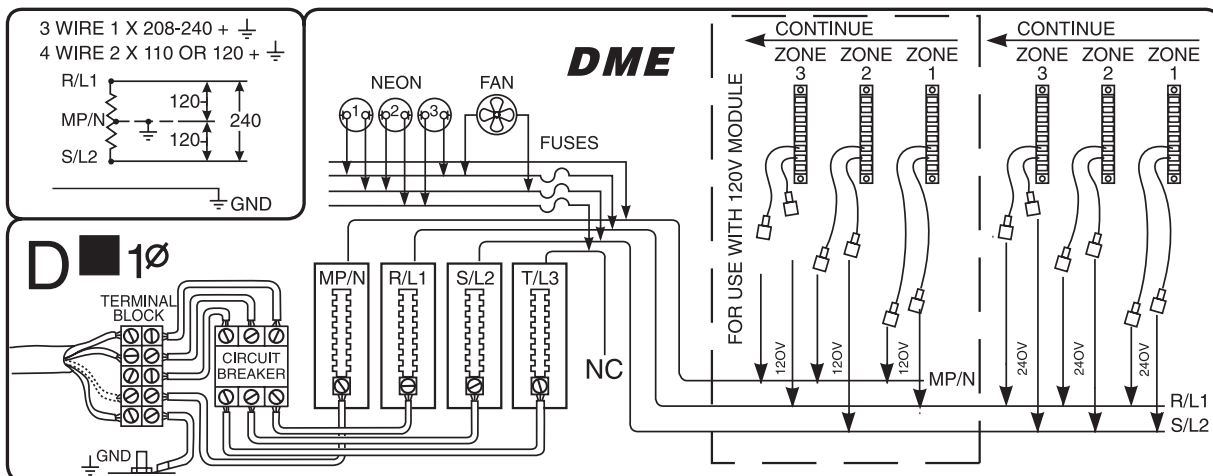

Above diagram depicts two different wiring configurations. One is 208-240 volt, single-phase, 3-wire. Note that lines R/L1 and S/L2 are connected through the circuit breaker to the appropriate terminal strips. All zones will be connected between R/L1 and S/L2. MP/N is common with ground and is not connected through the circuit breaker.

In the 120 volt connection (zone connections shown within the dashed-line area), the 120 volts is developed between R/L1 and MP/N and S/L2 and MP/N. Again, ground and MP/N are not connected through the circuit breaker. Each zone in this system will be connected to MP/N and either R/L1 or S/L2. Line balance is achieved by alternating between R/L1 and S/L2.

Alternate Cable Configuration

DME® Smart Series® Conversion Cables



Combination Mold Power and Thermocouple Conversion Cables allow ease of conversion between Mold-Masters and DME systems

- Mold Power and Thermocouple combined in a single cable
- Conversion for 12 zones
- Cables available in standard lengths of 10' and 20' (custom lengths are available)

Item Number	Mold Power Zones	Thermocouple Zones	Cable Length	Mainframe Connector	Mold Connector	Splits
PITC1210YFE	12	12	10'	DME "G" Series	HBE48 (Mold Master MPlug.12)	5 (Frame End)
PITC1220YFE			20'			
PITC1210YME			10'	HBE48 (Mold Master MPlug.12)	DME "G" Series	5 (Mold End)
PITC1220YME			20'			

Works with the following connectors:



[PIC12G](#)



[MTC12G](#)



[MPlug.12](#)

Alternate Cable Configuration

DME® Smart Series® Conversion Cables

5-ZONES OF CONTROL		
B	PTC05TB	5-ZONE TERMINAL MOUNTING BOX
C	MPC05C10 / 20G	5-ZONE MOLD POWER CABLE; 10' OR 20' O.A.L.
D	PIC05	5-ZONE MOLD POWER INPUT CONNECTOR
E	TC05C10 / 20G	5-ZONE THERMOCOUPLE CABLE; 10' OR 20' O.A.L.
F	MTC05	5-ZONE MOLD THERMOCOUPLE CONNECTOR



8-ZONES OF CONTROL		
B	PTC08TB	8-ZONE TERMINAL MOUNTING BOX
C	MPC08C10 / 20G	8-ZONE MOLD POWER CABLE; 10' OR 20' O.A.L.
D	PIC08	8-ZONE MOLD POWER INPUT CONNECTOR
E	TC08C10 / 20G	8-ZONE THERMOCOUPLE CABLE; 10' OR 20' O.A.L.
F	MTC08	8-ZONE MOLD THERMOCOUPLE CONNECTOR



12-ZONES OF CONTROL		
B	PTC12TB	12-ZONE TERMINAL MOUNTING BOX
C	MPC12C10 / 20G	12-ZONE MOLD POWER CABLE; 10' OR 20' O.A.L.
D	PIC12	12-ZONE MOLD POWER INPUT CONNECTOR
E	TC12C10 / 20G	12-ZONE THERMOCOUPLE CABLE; 10' OR 20' O.A.L.
F	MTC12	12-ZONE MOLD THERMOCOUPLE CONNECTOR

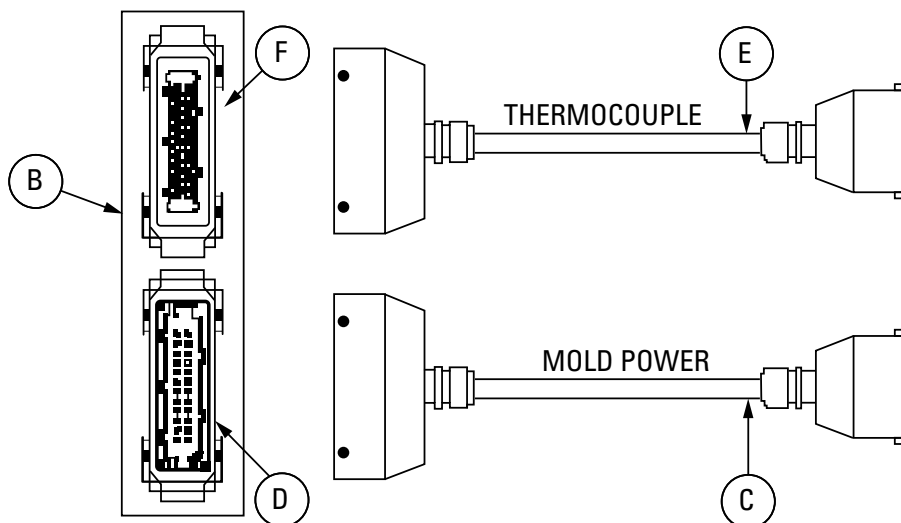

Alternate Cable Configuration

TYPICAL MOLD CONNECTOR WIRING DIAGRAM (REVISION "A")

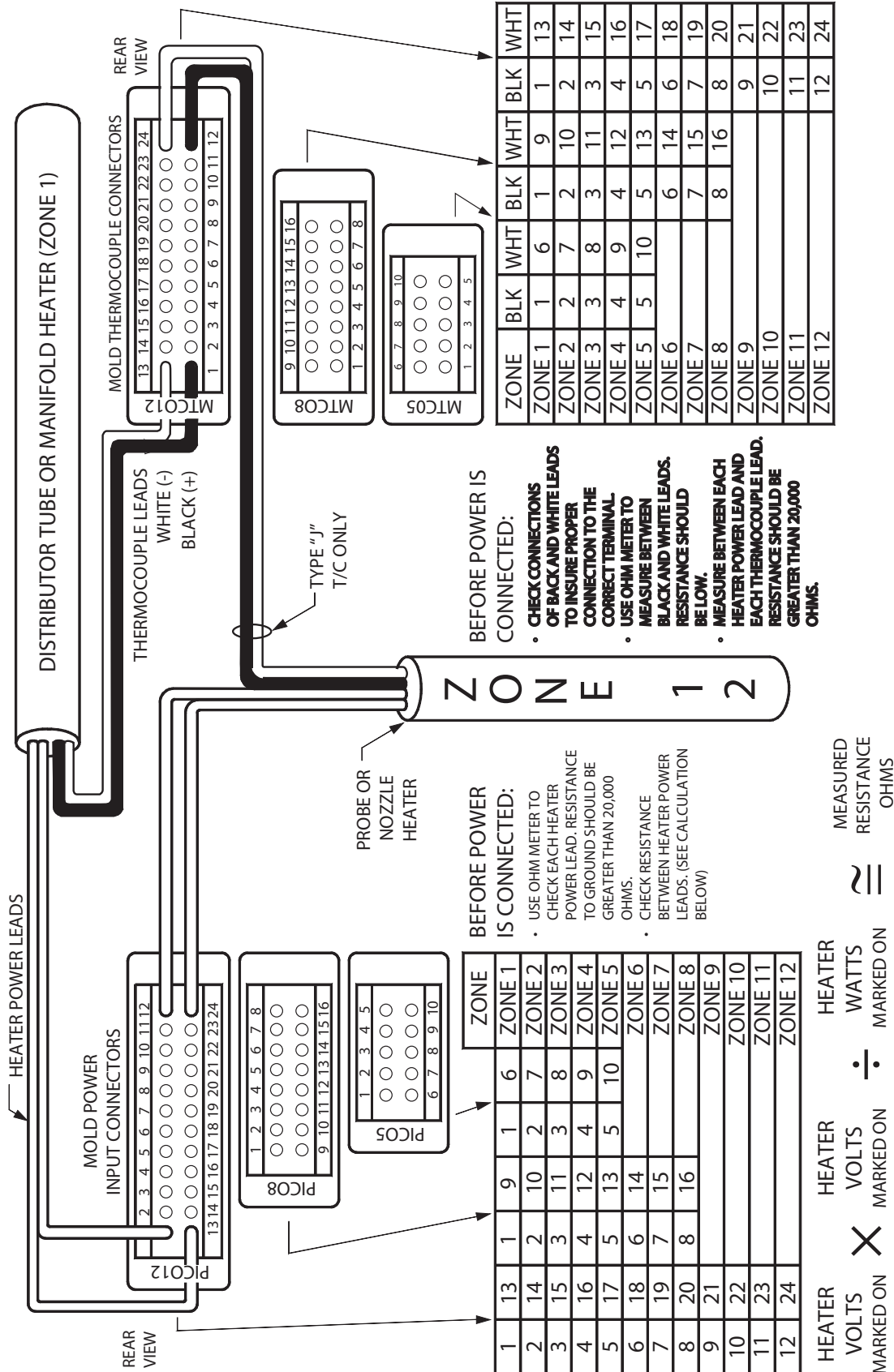

Terminal Box Detail & Mold Connectors

EUROPEAN CONFIGURATION

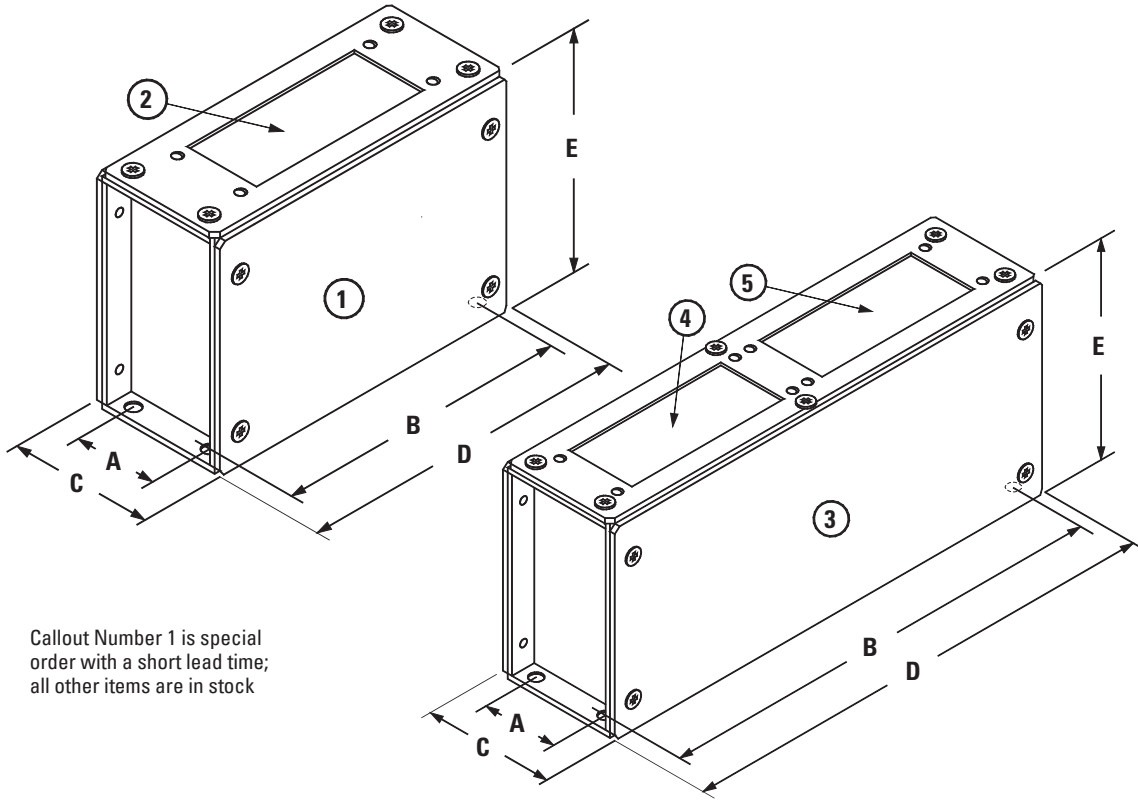

Callout Number 1 is special order with a short lead time; all other items are in stock

CALLOUT NUMBER	ITEM NUMBER TERMINAL BOX	CALLOUT NUMBER	ITEM NUMBER MOLD CONNECTOR	DIMENSIONS									
				A		B		C		D		E	
1	PT05TB	2	PIC05	1.50"	38mm	4.25"	108mm	2.44"	62mm	4.88"	124mm	4.10"	104mm
1	PT05TB	2	MTC05	1.50"	38mm	4.25"	108mm	2.44"	62mm	4.88"	124mm	4.10"	104mm
1	PT08TB	2	PIC08	1.50"	38mm	4.99"	127mm	2.44"	62mm	5.61"	142mm	4.10"	104mm
1	PT08TB	2	MTC08	1.50"	38mm	4.99"	127mm	2.44"	62mm	5.61"	142mm	4.10"	104mm
1	PT012TB	2	PIC012	1.50"	38mm	6.05"	154mm	2.44"	62mm	6.68"	170mm	4.10"	104mm
1	PT012TB	2	MTC012	1.50"	38mm	6.05"	154mm	2.44"	62mm	6.68"	170mm	4.10"	104mm
3	PTC05TB	4	PIC05	1.50"	38mm	8.84"	225mm	2.44"	62mm	9.47"	241mm	4.10"	104mm
		5	MTC05	1.50"	38mm	8.84"	225mm	2.44"	62mm	9.47"	241mm	4.10"	104mm
3	PTC08TB	4	PIC08	1.50"	38mm	9.91"	252mm	2.44"	62mm	10.53"	267mm	4.10"	104mm
		5	MTC08	1.50"	38mm	9.91"	252mm	2.44"	62mm	10.53"	267mm	4.10"	104mm
3	PTC012TB	4	PIC012	1.50"	38mm	12.17"	309mm	2.44"	62mm	12.79"	325mm	4.10"	104mm
		5	MTC012	1.50"	38mm	12.17"	309mm	2.44"	62mm	12.79"	325mm	4.10"	104mm

NOTE: ALLOW AN ADDITIONAL 0.25" (10mm) IN HEIGHT AND WIDTH FOR SCREW HEAD CLEARANCE

Me Temperature Controllers

SMART SERIES® Me

Hot Runner Temperature Control Made Simple and Economical

The Me controller platform combines essential features with advanced APS Technology for precision hot runner temperature control. Powerful performance from a compact unit that helps improve part quality and minimize scrap. Optimize the performance of any hot runner system and unlock your operations full potential .

KEY FEATURES

INTUITIVE TOUCH SCREEN COLOR DISPLAY

- Simple, user friendly interface.
- Allows for immediate familiarization.
- Monitor up to 12 zones at once.

INTEGRATED 15-AMP CONTROL CARDS

- Power to control a wide range of hot runner zones from nozzle tips to larger manifolds.
- On-board heater fuses.
- Quick and easy service access from the cabinet top and bottom.

COMPACT, STACKABLE CABINET DESIGN

- Preserves valuable space.
- Can be placed almost anywhere.
- Available in 6 or 12 zone configurations.
- Lightweight.

2 YEAR COMPREHENSIVE WARRANTY

- Worry free global support coverage.
- Protects against manufacturers defects (fuses excluded).



ITEM NUMBER	DESCRIPTION
Me6-15SS	6 Zones of Control
Me12-15SS	12 Zones of Control

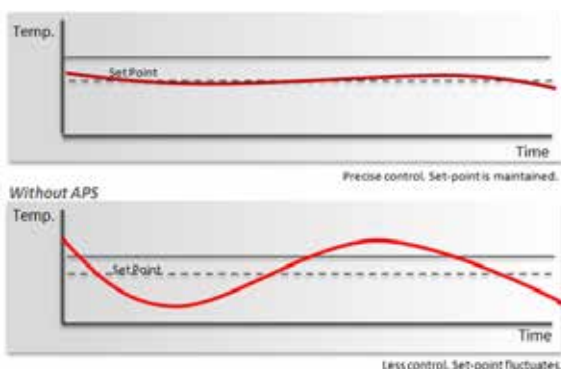

SIMPLE TOUCH SCREEN CONTROLS

Probe 1	Probe 2	Probe 3	Probe 4	
250	250	249	249	Run
250 °C	250 °C	250 °C	250 °C	Standby
1.0 A	1.1 A	1.2 A	1.3 A	Shutdn
Probe 5	Probe 6	Probe 7	Probe 8	
249	249	250	250	Boost
250 °C	250 °C	250 °C	250 °C	Stop
1.4 A	1.5 A	1.6 A	1.7 A	
Probe 9	Probe 10	Probe 11	Probe 12	
250	250	250	250	Tool
250 °C	250 °C	250 °C	250 °C	
1.8 A	1.9 A	2.0 A	2.1 A	
Mode RUN				Status NORMAL

Me Temperature Controllers

SMART SERIES® Me

CAPABILITIES

Control Features	Operational Features	Protection Features	Alarms
APS (Adaptive Process System)	Auto/Manual Control	On-Board Load Fuses	Audible Alarm
Phase Angle, Burst Firing	Zone "on," "off" and "locked off"	Soft Start	Zone Alarm Configure
Infield Calibration Mode	Menu "Auto Save"	Continuous Ground Fault Detection	(+) High Temperature
Thermocouple Slave (Manual)	Tool Store (4)	Current Measurement	(-) Low Temperature
Auto Standby/Alarm Output	USB Port	Overload Protection	T/C Open (remembered % output)
Wet Heater Bakeout		Automatic Tool Diagnostics	T/C Reversed
T/C Filtering		Plastic Leak Detection (Manual)	Open Fuse
Delta/Wye Convertible Option		LED Fault Indicator (Scan)	Open Heater
Interface Autopilot Control			Shorted Heater/Wet
Set Point Limit			Ground Fault Detection
Set Power Limit			Plastic Leak Detection
Auto Load % Output			
Uniform Start-Up			

SPECIFICATIONS

User Interface	Full Color LCD Touch Screen	Frequency	50 - 60 Hz Automatic Switching
Display Size	5"	Ambient Temperature Range	5 - 450°C (41 - 113°F)
Cabinet Dimensions	36cm x 39cm x 20cm (14" x 15" x 8")	Humidity Range	Up to 95% non-condensing
# of Zones (Max)	6 or 12	Ground Fault Detection	40mA per Zone
Control Algorithm	APS (Adaptive Process System)	Alarm Output	Closing Contact Relay 5A, 230V (Max)
Power Control	Phase Angle & Burst Firing Modes (Time Proportional, Zero-Crossing)	T/C Connector	HD25 Male - DME Standard
Temp. Resolution	1 (0°C or 0°F)	Power Connector	HD25 Female - DME Standard
Power Response Time	8.3 ms at 60 Hz	Main Circuit Breaker	32Amp 3 pole
Temperature Scale	0°C or 0°F (Software Selectable)	Overload Protection	Semi-conductor fuses on both heater legs
Thermocouple	J or K-Type (Software Selectable)	Heater Fuses	15A @ 220V Super Fast Blow Type (FF)
Operating Range	0 - 472°C (32 - 882°F)	Control Modes	Closed Loop (Auto), Open Loop (Manual), Standby, Boost, Slave
Output Voltage (Max)	264 VAC	Ports	USB
Supply Voltage	200/240V 3P Delta or 380/415V 3P Star with Neutral (480V, 3P with optional transformer)	LED Indicators	Scan
		Languages	English, French, German, Spanish, Polish, Russian, Chinese, Japanese, Czech, Italian, Hungarian, Turkish, Portuguese, Korean



M2+ Temperature Controllers

SMART SERIES® M2+

Advanced Hot Runner Temperature Control & Process Monitoring

A fully featured controller platform with advanced capabilities for superior molding performance. Well suited for tight process control on all hot runner systems, it is your best choice as a direct replacement for many existing outdated controller platforms.

Unlock your operations full potential.

KEY FEATURES

LARGE INTUITIVE TOUCH SCREEN CONTROLS

- Modernized interface
- Quick and easy to use
- Rapid response rates
- Familiar gestures like pinch-to-zoom
- Available in 8", 12" and 17" formats
- Locate monitor/user interface away from control cabinet with optional cable set

ADVANCED FUNCTIONALITY

- APS (Adaptive Process System) Technology, the industry's most advanced heat control algorithm
- Auto leak detection
- Auto tool diagnostics
- TC auto slave
- Hot runner power consumption (kW per hour) monitoring
- Graphical presentation of hot runner system for easy zone identification
- Purge Wizard
- And much more

IO ALARM INTERLOCK

- Interface with any injection machine
- Triggers an alarm when issues are identified
- Pauses the molding process until corrected
- Helps maintain process consistency

WIRELESS NETWORK CONTROL (WLAN)

- Multi cell operation
- Multiple IP operation
- Download/Upload tool set-up
- Valuable for clean room applications



M2+ Temperature Controllers

DME's Smart Series M2+ is available in zones numbering from 48 to 120, with touch screen ranging from 8 to 17" to suit your specific needs.

ITEM NUMBER	ZONES	MAIN AMPERAGE	INCLUDES	CABINET SIZE
M2XS-24-TS8P	24	40	8in DISPLAY w/ HD25 CONNECTORS	EXTRA SMALL
M2XS-24-TS12P	24	40	12in DISPLAY w/ HD25 CONNECTORS	EXTRA SMALL
M2S-36-TS8P	36	63	8in DISPLAY w/ HD25 CONNECTORS	SMALL
M2S-36-TS12P	36	63	12in DISPLAY w/ HD25 CONNECTORS	SMALL
M2S-36-TS17P	36	63	17In DISPLAY w/ HD25 CONNECTORS	SMALL
M2S-48-TS8P	48	63	8in DISPLAY w/ HD25 CONNECTORS	SMALL
M2S-48-TS12P	48	63	12in DISPLAY w/ HD25 CONNECTORS	SMALL
M2S-48-TS17P	48	63	17In DISPLAY w/ HD25 CONNECTORS	SMALL
M2M-60-TS8P	60	80	8in DISPLAY w/ HD25 CONNECTORS	MEDIUM
M2M-60-TS12P	60	80	12in DISPLAY w/ HD25 CONNECTORS	MEDIUM
M2M-60-TS17P	60	80	17In DISPLAY w/ HD25 CONNECTORS	MEDIUM
M2M-72-TS12P	72	80	12in DISPLAY w/ HD25 CONNECTORS	MEDIUM
M2M-72-TS17P	72	80	17In DISPLAY w/ HD25 CONNECTORS	MEDIUM
M2M-84-TS12P	84	100	12in DISPLAY w/ HD25 CONNECTORS	MEDIUM
M2M-84-TS17P	84	100	17In DISPLAY w/ HD25 CONNECTORS	MEDIUM
M2M-96-TS12P	96	125	12in DISPLAY w/ HD25 CONNECTORS	MEDIUM
M2M-96-TS17P	96	125	17In DISPLAY w/ HD25 CONNECTORS	MEDIUM
M2L-108-TS12P	108	150	12in DISPLAY w/ HD25 CONNECTORS	LARGE
M2L-108-TS17P	108	150	17In DISPLAY w/ HD25 CONNECTORS	LARGE
M2L-120-TS12P	120	150	12in DISPLAY w/ HD25 CONNECTORS	LARGE
M2L-120-TS17P	120	150	17In DISPLAY w/ HD25 CONNECTORS	LARGE

ITEM NUMBER	DESCRIPTION
M2DISPMNT	REMOTE DISPLAY MOUNT
M2DISPDATA CABLE	DISPLAY DATA CABLE - 30' (9m) LONG
M2DISPPOW CABLE	DISPLAY POWER CABLE - 30' (9m) LONG



M2+ Temperature Controllers

SMART SERIES® M2+

Precise Temperature Control and World Class Features

SPECIFICATIONS

User Interface	Full Color LCD Touch Screen
Display Sizes	8" (203mm), 12" (305mm), or 17" (432mm)
Control Algorithm	APS (Adaptive Process System)
Power Control	Phase Angle and Burst Firing Modes (Time Proportional, Zero-Crossing)
Control Accuracy	+/- 0.5°C (1°F)
Display Resolution	0.1 (°C or °F)
Power Response Time	8.3 ms at 60 Hz
Temperature Scale	°C or °F (Software Selectable)
Thermocouple	J or K-Type (Software Selectable)
Operating Range	0 - 472°C (32 - 882°F)
Output Voltage (Max)	264 VAC
Supply Voltage	200/240V 3P Delta or 380/415V 3P Star with Neutral (480V, 3P with optional transformer)
Frequency	50 - 60 Hz Automatic Switching
Ambient Temperature Range	5 - 45°C (41 - 113°F)
Humidity Range	Up to 95% non-condensing
Ground Fault Detection	40mA per Zone
Alarm Output	Closing Contact Relay 5A, 230V (Max)
T/C Connector	DME Standard HD25 Male
Power Connector	DME Standard HD25 Female
Input Protection	63mA Nano Fuses on Both T/C Legs
Overload Protection	Semi-conductor fuses on both heater legs
Heater Fuses	15A @ 220V Fast Blow Type
Control Modes	Closed Loop (Auto), Open Loop (Manual), Standby, Boost, Slave
Ports	USB and Ethernet
LED Indicators	Scan, Fuse, Thermocouple, Failure, Ground Fault, Power%
Communications	SPI, Real VNC, Modbus, OPC-UA
Languages	English, French, German, Portuguese, Spanish, Polish, Russian, Chinese, Japanese, Czech, Italian, Turkish

Cabinet Size	# of Cards (Max)	# of Zones (Max)	Dimensions WxDxH cm (in.)
XS	6	24	31x45x81 (12x18x32)
S	12	48	36x45x96 (14x18x38)
M	24	96	45x60x116 (18x24x46)
L	36	144	45x60x141 (18x24x56)
XL	63	252	

Based on 4z-15A cards. Increase max zones with 6z-5A cards

Mt2 Temperature Controllers

SMART SERIES® Mt2

Precision Temperature Control for 2-zone Hot Sprue Applications

The Mt platform combines essential features with advanced APS Technology for precision temperature control and essential protection features. Powerful performance from a compact unit that helps improve part quality and minimize scrap.

Optimize the performance of any hot runner system and unlock your operations full potential with Smart Series.

KEY FEATURES

INTUITIVE TOUCH SCREEN COLOR DISPLAY

- Simple, user friendly interface
- Allows for immediate familiarization
- Monitor 2 zones at once
- Continuous display of % power and current

2 ZONE CONTROL CARD

- On-board heater and thermocouple fuses
- Eliminates excess wiring and improves accessibility
- Servicing is quick and easy, minimizing downtime

COMPACT CABINET DESIGN

- Preserves valuable space
- Can be placed almost anywhere

DURABLE INDUSTRIAL DESIGN

- Metal enclosure and heavy duty connectors
- High reliability

2 YEAR COMPREHENSIVE WARRANTY

- Worry free global support coverage
- Protects against manufacturers defects (fuses excluded)



View

- Temperature
- Set Point
- Current (A)
- Power %

SIMPLE TOUCH SCREEN CONTROLS

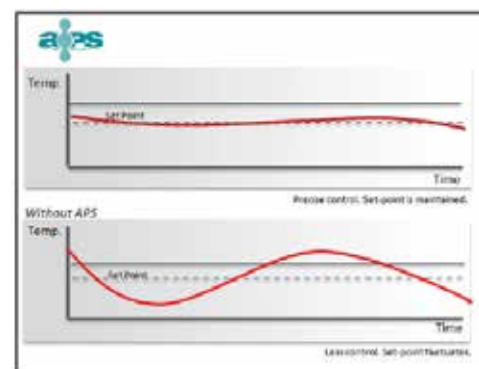

Mt2 Temperature Controllers

SMART SERIES® Mt2

SPECIFICATIONS

User Interface	Full Color LCD Touch Screen
Display Size	2" (51mm) - 176 x 200 pixels
Control Algorithm	36cm x 39cm x 20cm (14" x 15" x 8")
Power Control	Phase Angle & Burst Firing Modes (Time Proportional, Zero-Crossing)
Control Accuracy	+/- 0.5°C (1°F)
Display Resolution	1 (°C or °F)
Power Response Time	8.3 ms at 60 Hz
Temp. Resolution	1 (0°C or 0°F)
Temperature Scale	0°C or 0°F (Software Selectable)
Thermocouple	J or K-Type (Software Selectable)
Operating Range	0 - 472°C (32 - 882°F)
Output Voltage (Max)	264 VAC
Supply Voltage	240V Single Phase - 10' Power Cord Included
Frequency	50 - 60 Hz Automatic Switching
Ambient Temperature Range	5 - 450°C (41 - 113°F)
Humidity Range	Up to 95% non-condensing
Ground Fault Detection	40mA per Zone
Mold Power and Thermocouple Connection	10' Integrated Power and T/C Cable Mt2-15SS: HB10 Double Latch Mt2-10SS: (2) CKPTF1 Split Cable
Input Protection	63mA Nano Fuses on Both T/C legs
Overload Protection	Semi-conductor fuses on both heater legs
Heater Fuses	15A or 10A @ 220V Fast Blow Type
Control Modes	Closed Loop (Auto), Open Loop (Manual)
Languages	English, French, German, Chinese



Item No.: Mt2-15SS
15A B10 Mold End Connector



Item No.: MTPTC215 Mold Connector
Uses MTC5TBG Mold Terminal Box



Item No.: Mt2-10SS
10A (2) CKPTF1 Mold End Connectors



Item No.: MPTC210CP
Adapter Cable
B10 to (2) CKPTF1 Mold End Connectors
Requires controller fuse change to 10A
(10 amp fuses supplied with cable)



Equatemp® MD-series
Dual-Zone Hot Sprue
Bushing

CAPABILITIES

Control Features
APS (Adaptive Process System)
Phase Angle, Burst Firing
Infield Calibration Mode
Thermocouple Slave (Manual)
T/C Auto/Man Kick-Off
Wet Heater Break-out
T/C Filtering

Operational Features
Auto/Manual Control
Zone "on," "off"
Menu "Auto Save"
Boost/Standby (Manual)

Protection Features
On-Board Load Fuses
On-Board T/C Fuses
Soft Start
Continuous Ground Fault Detection
Current Measurement
Overload Protection
Short Circuit Protection

Alarms
Zone Alarm Configure
(+) High Temperature
(-) Low Temperature
T/C Open (remembered % output)
T/C Reversed
Open Fuse
Open Heater
Shorted Heater/Wet
Ground Fault Detection



Valve Gate Controls



ENERGY EFFICIENT, RELIABLE
AND COMPACT HYDRAULIC AND
PNEUMATIC CONTROLS

DME Valve Gate Controllers

DME Smart Series® SVG Sequential Valve Gate Controllers

Enhanced control of valve gate sequence and timing for pneumatic or hydraulic systems. Improve mold balance and part quality. Essential control when molding complex or large parts.

KEY FEATURES

ENHANCED FILL CONTROL

- Programmable sequence and timing
- Manage up to 24 valves
- Up to 4 steps per cycle

LARGE INTUITIVE TOUCH SCREEN

- Quick and easy process monitoring and adjustments
- Real time graphs
- Configurable *Easy View* status page

IMM COMMUNICATIONS

- Controller links triggers to the IMM
- Ensures process precision and repeatability

UNIVERSAL COMPATIBILITY

- Easily connect to DME or any other manufacturers' Valve Gated Hot Runner Systems

OPTIONAL HYDRAULIC FLOW CONTROL VALVES

- Control and adjust valve pin opening speeds
- Minimize/eliminate visual defects common to large part production
- Upgrade your hydraulic system anytime



SVG-12



SVG-C12

SVG Standalone Controllers

Item Number	Description
SVG-C12†	12 gate control
SVG-12	12 gate control
SVG-24 *	24 gate control

* not stocked

Includes: 4.8m (15') Cable Set and Quick Start Guide

† 12 gate total load output must not exceed 1 amp per circuit / 288 watts maximum

Quick and easy process set-up



Optional Accessories

ITEM NUMBER	DESCRIPTION
ITSPTROLLEY	STAND



Stand

DME Valve Gate Controllers

KEY TECHNICAL FEATURES AT A GLANCE

- Digital outputs – fused at 2 amps
- Digital inputs - pin position back/forward
- Integrated 24 VDC power supply to drive valve gate solenoids
- 7" color touch screen on standalone controller
- Controls single or dual coil solenoid valves
- Real time valve status graph
- Configurable Easy View status page

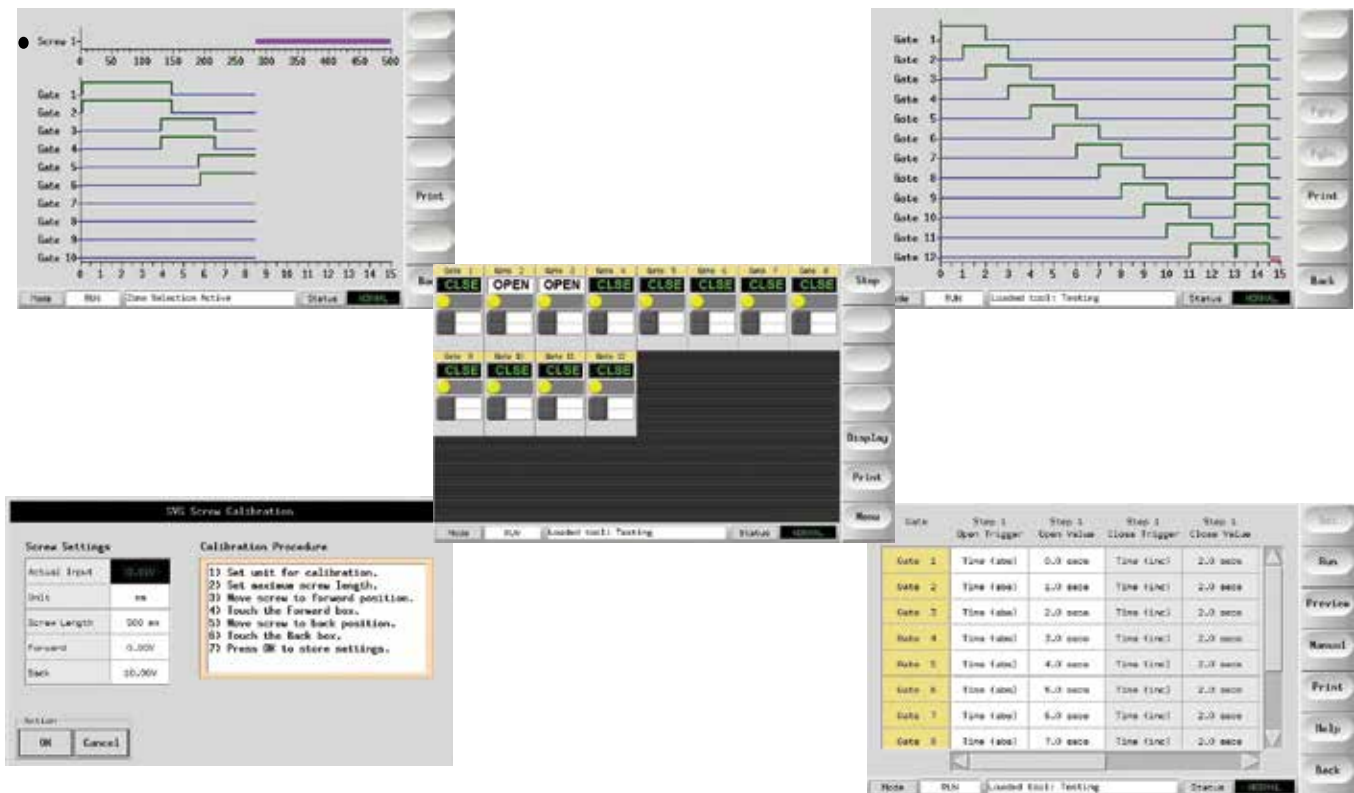

PROGRAMMABLE TRIGGERS & ALARMS

- Digital input – sequence start trigger
- Digital input triggers – programmable sequence triggers
- (2) Analog inputs 0-10 volts
- Analog input 4-20ma
- Remote enable signal – from IMM
- Fault relay output (dry contact) – to IMM
- Dry contact or 24VDC input triggering
- Controller includes 15ft (4.8m) solenoid power cable

DME Valve Gate Control Systems - Pneumatic

Complete pneumatic control systems include the SVG-12 controller, a pneumatic valve bank and the connecting control cable

BENEFITS

- Sequential valve gate control technology integrated in a precise controller with a full compliment of features.
- SVGP systems are air cooled & energy efficient
- Designed to easily connect to any valve gate system
- Precise filling control with performance graphs displaying time and position, with up to 4 steps per cycle
- (2) digital and analog triggers for 2-shot applications



SVG-12

CONFIGURATION

- Program valve actuation by time or injection screw position
- Pin position feedback for gate open /close confirmation (optional)
- Automatic and manual mode for individual gate control
- Absolute and incremental timer selections
- Single or dual acting solenoid valves for gate activation, valve banks relocatable
- Calibrate analog signals for position, pressure and volumetric settings
- Reconfigure pin position feedback inputs for 12 additional sequences
- 120/220V single-phase - 15' power input cord
- Includes 15ft (4.8m) solenoid power cable



ITEM NUMBER	DESCRIPTION	INCLUDES
SVGP2	2 ZONE PNEUMATIC	SVG12 HMI, 1-2 SOLENOID VALVE BANK
SVGP4	4 ZONE PNEUMATIC	SVG12 HMI, 1-4 SOLENOID VALVE BANK
SVGP6	6 ZONE PNEUMATIC	SVG12 HMI, 1-6 SOLENOID VALVE BANK
SVGP8	8 ZONE PNEUMATIC	SVG12 HMI, 1-8 SOLENOID VALVE BANK
SVGP12	12 ZONE PNEUMATIC	SVG12 HMI, 2-8 SOLENOID VALVE BANKS

If you do not see the number of controlled zones required in the table above please contact us.

Pneumatic Power Pack Only

Can be used with SVG-12 and SVG-C12 Controllers, purchased separately.

Options

- SVG Controller (SVG-12, -24 or SVG-C12)
- Pneumatic valve banks
- Temperature control intergration

Notes

- Hoses & fittings sold separately
- 2-year warranty



Model #	Tank Size (gal/L)	Pressure Ratio	Supply Pressure PSI (Min/ Max)	Max Rated Pressure (PSI)	System Rating (PSI)	Max Temp (°F)	Connectors	Solenoids (Zones)
PNEUPWRPACK600	10 / 38	2:1	15 / 150	300	200	180	1/2" FNPT	2-24

DME Valve Gate Control Systems - Hydraulic

The DME hydraulic valve gate control systems are complete, fully assembled systems that include:

- SVG-12 Valve Gate Controller
- Complete 1200 or 1600 PSI Hydraulic Power Unit:
 - Oil Tank / Accumulator
 - Electric motor and pump
 - Integrated electronic controls
 - Hydraulic solenoid valve bank
 - All plumbing complete
- Connecting control cable (SVG-12 to valve bank) 15" (4.8m)

CONFIGURATION

- Program valve actuation by time or injection screw position
- Pin position feedback for gate open /close confirmation (optional)
- Automatic and manual mode for individual gate control
- Absolute and incremental timer selections
- Single or dual acting solenoid valves for gate activation, valve banks relocatable
- Calibrate analog signals for position, pressure and volumetric settings
- Configure up to 4 cards to control as many as 48 single acting valve gates
- Reconfigure pin position feedback inputs for 12 additional sequences
- 500 or 1000 Watt 24VDC power supply
- Available as standalone controller or semi-integrated into the ITSP or M2+ temperature controller



Hydraulic Valve Gate Controllers - SVGH

ITEM NUMBER	DESCRIPTION	POWER PACK PSI	CONSISTS OF
SVGH122	2 ZONE HYDRAULIC	3L-1200 PSI 240VAC - 3 Phase	SVG12 HMI, POWER PACK, 1-2 SOLENOID VALVE BANK, STAND
SVGH124	4 ZONE HYDRAULIC		SVG12 HMI, POWER PACK, 1-4 SOLENOID VALVE BANK, STAND
SVGH126	6 ZONE HYDRAULIC		SVG12 HMI, POWER PACK, 1-6 SOLENOID VALVE BANK, STAND
SVGH128	8 ZONE HYDRAULIC		SVG12 HMI, POWER PACK, 1-8 SOLENOID VALVE BANK, STAND
SVGH1212	12 ZONE HYDRAULIC		SVG12 HMI, POWER PACK, 2-6 SOLENOID VALVE BANKS, STAND
SVGH162	2 ZONE HYDRAULIC	6L-1600 PSI 240VAC - 3 Phase	SVG12 HMI, POWER PACK, 1-2 SOLENOID VALVE BANK, STAND
SVGH164	4 ZONE HYDRAULIC		SVG12 HMI, POWER PACK, 1-4 SOLENOID VALVE BANK, STAND
SVGH166	6 ZONE HYDRAULIC		SVG12 HMI, POWER PACK, 1-6 SOLENOID VALVE BANK, STAND
SVGH168	8 ZONE HYDRAULIC		SVG12 HMI, POWER PACK, 1-8 SOLENOID VALVE BANK, STAND
SVGH1612	12 ZONE HYDRAULIC		SVG12 HMI, POWER PACK, 2-6 SOLENOID VALVE BANKS, STAND
SVGH1616	16 ZONE HYDRAULIC		SVG24 HMI, POWER PACK, 2-8 SOLENOID VALVE BANKS, STAND
SVGH1624	24 ZONE HYDRAULIC		SVG24 HMI, POWER PACK, 3-8 SOLENOID VALVE BANKS, STAND

If you do not see the number of controlled zones required in the table above please contact us.

Hydraulic Power Packs Only

Model #	Tank Size (gal/L)	PSI (Bar)	Throughput	Motor Type	Power Supply	Oil Type	Connectors	Solenoids (Zones)
HYDPWRUNIT3L	0.8 / 3	1300 (90)	1.8 GPM	AC	230 VAC, 3 phase, 60 Hz Optional 480V, 3P	AW32	1/2" NPT	2-24
HYDPWRUNIT6L	1.6 / 6	1600 (110)						

Cables & Air Valve Assemblies

Valve Gate Control Cables

ITEM NUMBER

VCTBA06



12 zone valve gate control cable 15' (4.8m) to connect SVG-12 or SVG-C12 to VCAP pneumatic valve bank.

ITEM NUMBER

MCABLE.12.PWR/DL



12 zone valve gate control cable 15' (4.8m) to connect SVG-12 or SVG-C12 to pneumatic or hydraulic valve bank.

VCAP multi-station air valve assemblies

The VCAP series offers 4-station (0400), 6-station (0600), 8-station (0800), 10-station (1000), and 12-station (1200) valve assemblies. The single-solenoid valves are spring returned and designed to run from 24 VDC +/- 10%. The air supply (maximum rated pressure 145 PSI) can be lubricated or non-lubricated – dry air is preferred but the valve is designed to tolerate some moisture.

Quick connects are provided on all air outputs to accept standard 1/4" tubing. The de-energized outputs, used for closing valve gates, feature check valves to ensure that unused valves do not leak air.

ITEM NUMBER	DESCRIPTION
VCAP0400	4-STATION AIR VALVE ASSEMBLY
VCAP0600	6-STATION AIR VALVE ASSEMBLY
VCAP0800	8-STATION AIR VALVE ASSEMBLY
VCAP1000	10-STATION AIR VALVE ASSEMBLY
VCAP1200	12-STATION AIR VALVE ASSEMBLY



Note: Each valve assembly includes a DB25 male to DB25 female valve control cable.

DME Single Zone Timer

DME Single Zone Timer: [TCM03024D](#)

Versatile for virtually any type of operation that requires a timer, including single-zone valve gate systems, core pulls, and air sweeps.

- Unit plugs directly into DME Smart Series Mainframes
- Test button (green light indicates power out)
- Yellow light indicates trigger signal being applied or timer in operation
- Trigger signal has two available sources – dry set of contacts or 24 VDC input
- Trigger input signal can be ganged to operate more than one timer when multiple units are used (24 VDC input only)
- Input signal and output power can be used from timer front panel connectors or DME mainframe cables
- Thermocouple cable serves as trigger signal; power cable serves as 24 VDC power supply to any 24 VDC solenoid valve



Shown next to a SSM1512 Temperature Controller in a Standard 2-Zone Smart Series Mainframe.

DME Single Zone Timers (TCM03024D) are highly accurate, solid state timers that feature resolution to 1/100 of second, far exceeding the industry standard of 1/10 of a second.

Technical Support

Customer Power Requirement Worksheet – Option A Delta 3-Phase Power 240 VAC

It is the customer's responsibility to make sure his Hot Runner Mold Application will not exceed the power limitations of the DME Hot Runner Control System Main Circuit Breaker. Even though each slot may be rated at 15 amps, all slots CANNOT necessarily deliver full power from all zones simultaneously.

PHASE A POWER		PHASE B POWER		PHASE C POWER	
ZONE #	WATTAGE	ZONE #	WATTAGE	ZONE #	WATTAGE
1		2		3	
4		5		6	
7		8		9	
10		11		12	
13		14		15	
16		17		18	
19		20		21	
22		23		24	
25		26		27	
28		29		30	
31		32		33	
34		35		36	
37		38		39	
40		41		42	
43		44		45	
46		47		48	
49		50		51	
52		53		54	
55		56		57	
58		59		60	
TOTAL PHASE A WATTS		TOTAL PHASE B WATTS		TOTAL PHASE C WATTS	

Record Product Breaker Size Phase Wattage Not To Exceed		Record Product Breaker Size Phase Wattage Not To Exceed		Record Product Breaker Size Phase Wattage Not To Exceed	
---	--	---	--	---	--

Breaker Wattage Size Table – For Delta 240 VAC 3-Phase Power

BREAKER RATING AMPS	MAXIMUM PHASE WATTS EACH PHASE A,B,C CANNOT EXCEED THIS VALUE	MAXIMUM PHASE AMPS EACH PHASE A,B,C CANNOT EXCEED THIS VALUE
10 AMP	1,386 WATTS	5.77 AMPS
20 AMP	2,771 WATTS	11.55 AMPS
30 AMP	4,157 WATTS	17.32 AMPS
40 AMP	5,542 WATTS	23.09 AMPS
50 AMP	6,928 WATTS	28.87 AMPS
63 AMP	8,729 WATTS	36.27 AMPS
70 AMP	9,699 WATTS	40.41 AMPS
100 AMP	13,856 WATTS	57.74 AMPS

For 3 Phase Delta Power: TOTAL WATTS = SquareRoot (3) x VoltsAC x AMPS
 MAXIMUM PHASE WATTS = TOTAL WATTS / 3

Temperature Control Warranty, Repairs & Returns

DME Temperature Controllers are warranted pursuant to DME Company's standard terms and conditions (see page 5) for the time periods set forth below. The warranty (i) *covers items sold and shipped [supplied in accordance with orders placed by the customer with DME on or after JULY 1, 2003], (ii) applies only to the original DME customer and, (iii) is not transferable to subsequent owners of the product except as specifically set forth herein (see Transferability below for conditions).*

WARRANTY PERIODS APPLICABLE TO SPECIFIED DME PRODUCTS; COVERAGE STARTS UPON DATE OF SHIPMENT:

Item	Coverage
DME Mold Controls and Valve Gate Controls (excluding Fuses & Triacs, Power Packs & Trolley as appropriate)	One (1) year - Pumping systems, Valves & Solenoids Two (2) years - Smart Series™ Mainframes & Modules TSP, TSP Plus & SVG Electronic Controllers

Replacement or repair will be made at the election of DME; implemented at a DME facility and/or by shipment of replacement parts to the customer for installation and/or return of defective parts to DME for repair.

Transferability:

This warranty may be transferred by the original DME Customer to a subsequent owner of the product if all of the following conditions exist: (i) the original DME Customer purchased the product for purposes of re-sale or other immediate transfer and DME was made aware of these purposes at the time of purchase in writing, (ii) within thirty (30) days from the date of invoice, DME is notified in writing of the transfer and provided with the name of the new owner (hereafter "Transferee"), the contact person of the Transferee and the Transferee's address.

