



DME

EQUIPMENT & SUPPLIES



Table of Contents

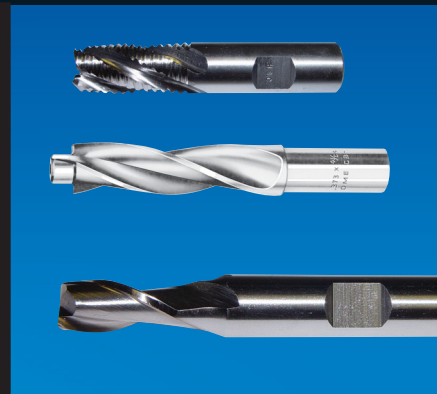

Cutting Tools.....7 to 18

High-speed cutting tools engineered for consistent accuracy, faster production and greater economy



Finishing/Polishing Equipment.....19 to 58

A wide range of finishing and polishing equipment and supplies that save time and help achieve desired finishes



ProWeld™.....59 to 62

Reduce repair costs up to 85% and increase the post-repair life of your molds



Molding Supplies.....63 to 76

Clean and protect your molds

Index

Abrasive Discs	48
Abrasive Sheets	48
Abrasive Stone Holders	37
Abrasive Stone Kit	47
Abrasive Stones	38,46
Accessories, Ultraform	30
Adapters, Ultraform	29
Bench Rolls	48
Ceramic Stones	26-27
Clamp Horns, Ultraform	28
Clamps, Mold	62
Comparison Kit, Mold Finish	51
Compound, Diamond	50
Compound, Polishing	49
Contour Roughing Services	14
Counterbores	9
Cutters, Carbide Rotary	39
Cutting Tools, Flexolap Sets	14-15
Cutting Tools, Midget Laps	14
Diamond Compound	50
Diamond Files	21-23, 41
Diamond Needle Files	45
Diamond Stones	28-29
Diamond Stones, Resin Bonded	23
Discs, Abrasive	55
Felt Bobs	36
Felt Polishing Kit	49
Felt Polishing Wheels	56
Files, Diamond	35
Files, Diamond Needle	52
Files, Habilis	52
Files, Steel	35
Finishing Applications	52
Grinders, Air	39
Habilis Files	45
Half Rifflers	42
Hoist Rings – INCH	60-61
Holders, Abrasive Disc	55
Jiffy-Tite Supplie	63
Lapping Tools	14-15, 33
Machine Reamers	10
Maxima EX Polisher Accessories	31
Maxima EX Polishing Controller	31
Maxima EX Polishing Handpieces, Motors and Heads	32-33
Micro-Welding System, ProWeld	59-63
Minitor D Belt Sander	34
Minitor D Profiler R	34
Mold Clamps	62
Mold Cleaner	58
Mold Finish Comparison Kit	51
Mold Release Sprays	59
Mold Saver	58
Mounted Points	40-41
Polishing Brushes	49
Polishing Compounds	49-50
Profiler R, Minitor D Series	40
ProWeld Micro-Welding System	54-56
Rifflers	49-51
Riffler Handles	50
Rifflers, Half	36
Rifflers, Die Sinkers	44
Rifflers, Moldmakers	42
Rifflers, Silversmith	43
Rout-A-Burr Tools	13
Sales and Ordering Information	4-5
Sprays, Mold Cleaner and Saver	65
Sprays, Mold Release	66
Sprue Bushing Reamers	12
Tapered Milling Cutters	8
Tool Clamps, Ultraform	34
Ultraform Accessories	30
Ultraform Adapters	29
Ultraform Stones and Files	24-25, 44
Ultraform Tooling	34-35
Ultraform Ultrasonic Finishing and Polishing Systems	16-20

Terms and Conditions of Sale

DME COMPANY LLC ("SELLER") TERMS AND CONDITIONS OF SALE

1. **ACCEPTANCE OF TERMS:** Seller's offer is expressly conditioned upon Buyer's acceptance of these Terms and Conditions, and Seller expressly objects to any additional or different terms proposed by Buyer. Any subsequent purchase order issued by Buyer shall constitute Buyer's agreement to these Terms and Conditions. Any contrary terms and conditions contained in any purchase order, facility entry form, or other instrument issued by the Buyer are expressly rejected and shall not apply to this transaction. Unless otherwise specified in the quotation, Seller's quotation shall expire 30 days from its date and may be modified or withdrawn by Seller before receipt of Buyer's conforming purchase order.

2. **PAYMENT TERMS:** Payment is due in accordance with any applicable progress, advance or other agreed upon payment schedule, or, if no such schedule has been agreed to, no later than 30 days from the date of invoice. Buyer shall pay a late payment charge computed at the lower of 1.5% per month on any overdue balance, or the maximum rate permitted by law. No cash discount is provided. If at any time Seller reasonably determines that Buyer's financial condition or payment history does not justify continuation of Seller's performance, Seller shall be entitled to require full or partial payment in advance or otherwise restructure payments, request additional forms of payment security, suspend its performance or terminate the order.

3. DELIVERY

3.1 In the United States, products are sold FCA Incoterms 2020 point of origin; for export sales, terms are FCA Incoterms port of export. Unless otherwise agreed in writing, title and risk of loss shall pass at the time of shipment. Buyer is responsible for all taxes, duties, fees, or other governmental charges related to its purchase of goods, with the sole exception of taxes on Seller's income. Unless otherwise agreed, Buyer shall pay all packing and delivery costs.

3.2 Seller's quoted lead times and targeted delivery dates are good faith estimates and are not binding on Seller. Buyer's acceptance of delivery of Seller's products from the carrier shall constitute a waiver of any claim for delay. If Seller notifies Buyer that the products are ready for shipment and Buyer delays delivery, then Seller may charge Buyer a storage fee equal to 1.5% of the contract price per month for each month of delay. Such storage fees are in addition to any other remedies Seller may have.

3.3 Buyer shall have a reasonable opportunity to inspect any products prior to shipment. Products shall be deemed to be accepted upon the earlier of: (i) inspection at Seller's plant (provided that no reasonable objection is then raised by Buyer), or (ii) if no inspection is requested, then at shipment. If an objection is made during inspection, then Products shall be deemed accepted upon resolution of the objection by Seller.

4. WARRANTY:

4.1 Seller's express product warranty be as stated in DME's order specification documentation and shall run from the date of shipment (the "Warranty Period"). During the Warranty Period, Seller warrants that the products and services sold hereunder will be free from material defects in material, workmanship and title (the "Warranty").

4.2 If, during the Warranty Period, Seller reasonably determines that the products do not meet the Warranty, then Seller shall, at its option, repair or replace the defective product or component thereof, reperform any defective services at Seller's expense, or refund or credit to Buyer its purchase price for the defective products or services.

4.3 The Warranty will be void and will not apply: (i) when Buyer fails to promptly notify Seller of any alleged defect, (ii) when Buyer fails to properly install, maintain, or operate the products, (iii) to any product or parts thereof with a useful life, under normal operating conditions, inherently shorter than 1 month, or (iv) to products which were not made by Seller or any of Seller's affiliates, provided that in such cases Seller shall use reasonable efforts to pass on to Buyer the manufacturer's warranty.

4.4 If Seller provides any parts or services to repair a product that is not under Warranty, then such parts and services will be billed to Buyer at Seller's prevailing rates for time and materials.

4.5 The Warranty set out above is the sole and exclusive warranty provided by Seller for its products and is in lieu of, and Seller expressly disclaims, all other warranties, express or implied, oral, written or statutory. **THERE ARE NO WARRANTIES OF MERCHANTABILITY OR FITNESS FOR PURPOSE FOR SELLER'S PRODUCTS.**

5. LIMITATION OF LIABILITIES:

5.1 Seller's total liability to Buyer arising out of or resulting from this Contract or related in any way to Seller's products or parts thereof shall not exceed the contract price for such products.

5.2 Seller shall not be liable for loss of profit or revenues, loss of use of products, interruption of business, downtime costs, increased operating costs, or any special, consequential, incidental indirect or punitive damages, whether incurred by Buyer or Buyer's customers.

5.3 Because the conditions of actual production in each end user's plant vary considerably, Buyer assumes all risk for the results obtained by use of Seller's products in the practice of any process, whether in terms of operating costs, general effectiveness, success or failure, and regardless of any oral or written statements made by Seller related to the use of its products.

6. **SECURITY INTEREST.** Buyer agrees that the Seller shall have and retain a purchase money security interest in the Products securing the payment of all sums becoming due hereunder. Such security interest shall attach, upon completion of manufacture, to the Products and to any parts or accessories attached to the Products and to the proceeds of any sale thereof. Buyer represents that the Products are being acquired for use in its business and that such Products will not, without prior written consent of the Seller, be sold or removed from the Buyer's place of business to which delivery is made. Buyer agrees upon Seller's request to execute any financing statements or other documents required to perfect, continue or renew Seller's security interest in the Products.

7. **CANCELLATION:** Unless otherwise agreed, Buyer may cancel all or any part of the order by written notice received by Seller before the completion of the order. On receipt of such cancellation notice, all work on the order or part thereof canceled will be stopped as promptly as is reasonably possible. Buyer will then be invoiced for and will pay to Seller as liquidated damages a cancellation charge. For completed items, the charge will be equal to their established prices. For items not completed, the charge will be equal to 135% of Seller's full cost as determined by Seller in accordance with Seller's standard accounting practices (which includes burden and overhead), plus a charge for any packing and storage, less a credit for the balance of the material as scrap.

8. **RETURNS:** All returned items require a Return Merchandise Authorization (RMA) number from DME. Returns are subject to a quality inspection to validate whether it can be returned to inventory. Mold bases, plates, special components, made-to-order products and other date-sensitive products are non-returnable items. Items returned to DME without prior authorization(RMA) may be returned to sender. Items returned for stated defect or non-conforming reason require detailed explanation. No products are returnable beyond 30 days after receipt.

9. **CONFIDENTIALITY.** Any nonpublic information, including without limitation, Seller's pricing information and the contents of Seller's quotation or proposal and Buyer's purchase order, exchanged between the parties is deemed confidential ("Confidential Information"). Each party agrees to maintain the other party's Confidential Information in confidence, to not disclose the same to any third parties, and to use it only in connection with this sale. These restrictions shall expire two (2) years after the date of disclosure. This provision does not modify or supersede any separate confidentiality or nondisclosure contract signed by the parties.

10. **FORCE MAJEURE:** Seller shall not be liable for any delay in performance or nonperformance which is due to war, fire, flood, pandemic, acts of God, acts of third parties, acts of governmental authority or any agency or commission thereof, accident, breakdown of products, differences with employees or similar or dissimilar causes beyond Seller's reasonable control, including but not limited to, those interfering with production, supply or transportation of products, raw materials or components or Seller's ability to obtain, on terms Seller deem reasonable, material, labor, products or transportation.

11. **MERGER CLAUSE:** This Contract entirely supersedes any prior oral or written representations, correspondence, proposals, or contracts between the parties regarding the products. This writing constitutes the final and total expression of such contract between the parties, and it is a complete and exclusive statement of the terms of that contract.

12. **ASSIGNMENT:** Neither party may assign this Contract without the written consent of the other party, except that Seller may assign this Contract to a third party that acquires substantially all of Seller's assets and Seller may assign the flow of funds arising out of this Contract.

13. **COMPLIANCE WITH LAWS.** Each party agrees to comply with all applicable laws in the performance of its obligations; Buyer shall not trans-ship, re-export, divert or redirect Products outside of the original country of delivery without Seller's prior written consent.

14. **GOVERNING LAW:** This Contract shall be governed by and construed in accordance with the laws of the State of Michigan, without regard to the Convention for the International Sale of Goods (CISG), which shall not apply.

Sales and Ordering Information

U.S.A.

TERMS AND CONDITIONS OF SALE: See previous page.

PHONE ORDERS – TOLL FREE: 800-626-6653. DME's Customer Service Dept. operates Monday through Friday from 7 a.m. to 7 p.m. E.S.T. Calls can be made from anywhere in the continental U.S. and Puerto Rico (Puerto Rico: use "137" prefix instead of "1"). Our Customer Service Representatives will be happy to answer your questions on DME products or services, provide on-the-spot feedback on product availability and shipping details, or take any messages you wish relayed to your local DME sales, manufacturing or technical service representatives.

MAIL ORDERS: If you prefer to order by mail, please address your order to:

DME Company, 29111 Stephenson Highway, Madison Heights, Michigan 48071-2330

ATTN: Customer Service Dept.

FAX: You may fax your order to:

DME Customer Service

248-544-5113 • 888-808-4363

CHECKS OR MONEY ORDERS: When paying invoices by check or money order, please make payable to DME Company. Include remittance copy of invoice and mail to:

DME Company, PO Box 854867 Minneapolis, MN 55485-4867

WALK-IN ORDERS, PICK-UPS AND RETURNS: If desired, ordered products in stock at your nearest DME Service Center can be picked up rather than shipped. Walk-in orders at Service Center locations can also be processed while you wait. Products being returned for repair or exchange should be processed through Customer Service prior to being returned.

SPECIAL MACHINING SERVICES: Prints for quotation on special machining work can be sent by EDI to dme_cad@dme.net or mailed to the Estimating Department of the DME manufacturing location nearest you. Call our toll-free number if desired to clarify location which serves your area.

Estimating locations are:

1117 Fairplains Street, Greenville, MI 48338, Tel. 616-754-4601, FAX: 616-225-3924

3275 Deziel Drive, Windsor, Ont N8W 5A5, Tel. 519-948-5001, FAX: 519-948-4652

464-466 Windy Point Drive, Glendale Heights, IL 60139, Tel. 630-469-4280, FAX: 630-469-4740 (estimating only)

Please add "DME Company" and "Attn: Estimating Dept." to above addresses when mailing prints. To obtain prices and delivery on special mold base orders or to check status of special work in progress please contact Customer Service.

CANADA

TERMS AND CONDITIONS OF SALE: See previous page.

ORDERS, QUOTES, PICKUPS, RETURNS: Please contact 800-387-6600

CHECK OR MONEY ORDERS: Make payable to DME Company. Include remittance copy of invoice and mail to:
3275 Deziel Drive, Windsor, ON N8W 5A5

Introduction

DME Company offers a wide range of equipment and supplies for moldmakers and molders. From high-speed cutting tools and a wide variety of finishing and polishing systems to a vast array of maintenance, repair and operation-related products, DME has the products you need to compete every step of the way.

Our line of cutting tools designed for moldmakers ranges from high-speed roughing mills and tapered milling cutters to counterbores, sprue bushing reamers, and dozens of lapping tools.

DME has been an essential finishing and polishing resource to its customers for decades with the Ultraform System that effectively replaces expensive and time-intensive hand-finishing operations. Two models of the ultrasonic device are designed to handle virtually any finishing need. An extensive assortment of tools and accessories come with each unit, and additional tooling is also available.

The Minitor D Series is a popular line of hand pieces that offers the latest in polishing technology while still providing tremendous flexibility and accuracy. The Minitor D series hand pieces are available in several models and with accessory heads to ensure that your finishing and polishing jobs get done to perfection.

An extensive line of files, rifflers, stones, stone holders and many other accessories provide the perfect resource necessary to achieve any finish. And, the DME Mold

Finish Comparison Kit – featuring 12 samples finished to SPI standards – provides a visual and numerical standard for both the selection of finishes required and a comparison to work in progress.

For high-quality mold repairs, the DME ProWeld Micro-Welding System provides precision results that increase mold life after every repair. The system is safe and easy to operate, and reduces repair costs by up to 85% with special metal alloys developed for all conventional types of steel.

Your molds will always be ready to perform with DME mold sprays. Available in aerosol cans or in one-gallon non-aerosol containers, DME Mold Cleaner, DME Mold Saver and DME Mold Release use the finest ingredients to complete the jobs for which they are intended.

For all of your processing needs, DME Molding Supplies offers thousands of economical, high-quality products from auxiliary equipment such as drying hoppers and storage bins to machine parts like screw tips and machine mounts. All of your plumbing, heating and other processing-related needs are better achieved with the high-quality, low-cost offerings from DME Molding Supplies.

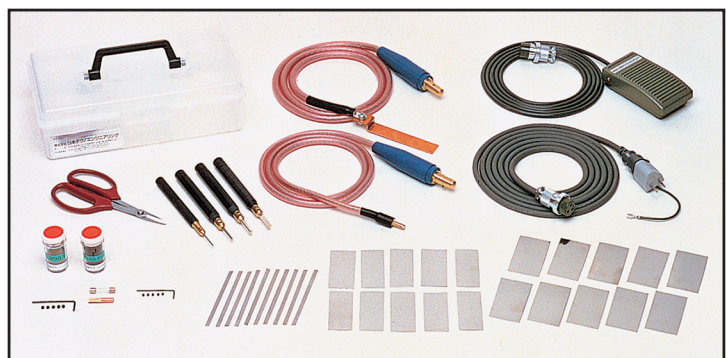

DME Cutting Tools

HIGH-SPEED CUTTING TOOLS
ENGINEERED FOR CONSISTENT
ACCURACY, FASTER PRODUCTION
AND GREATER ECONOMY

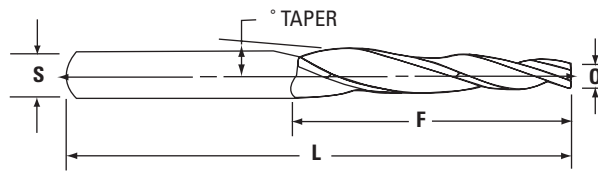

Tapered Milling Cutters

**3° TAPER PER SIDE**

ITEM NUMBER	O SMALL DIA.	F FLUTE LENGTH	S SHANK DIA.	L OVERALL LENGTH
C409	$\frac{1}{4}$	$2\frac{1}{4}$	$\frac{1}{2}$	$4\frac{1}{4}$

5° TAPER PER SIDE

ITEM NUMBER	O SMALL DIA.	F FLUTE LENGTH	S SHANK DIA.	L OVERALL LENGTH
E203	$\frac{1}{8}$	$\frac{3}{4}$	$\frac{3}{8}$	$2\frac{1}{2}$
E305	$\frac{3}{16}$	$1\frac{1}{4}$	$\frac{1}{2}$	$3\frac{3}{8}$
E409	$\frac{1}{4}$	$2\frac{1}{4}$	$\frac{5}{8}$	$4\frac{1}{4}$
E609	$\frac{3}{8}$	$2\frac{1}{4}$	$\frac{3}{4}$	$4\frac{1}{4}$

Counterbores



- Built-in chamfering operation
- Stub length for rigidity
- Three flute spiral design
- High speed steel

Here is a special purpose tool that not only performs its job well, but gives you added tooling performance besides. The built-in chamfer design automatically allows clearance for the radius under the Ejector Pin Head and insures proper seating of the pin.

DME Counterbores are hardened and precision ground from top quality high speed steel to give you cleaner cutting and longer life. The three-flute spiral design has been engineered to reduce tool wear and give faster cutting action through rapid chip clearance.

DME Counterbores can help make counterboring easier and reduce your tooling costs... and here's how:

1. Drill the retainer plate to suit your DME Ejector Pin diameter
2. Select the DME Counterbore with the same Item Number as the DME Ejector Pin to be used (*) and counterbore to the proper depth... And that's it!

(*) Example: For an EX17 Ejector Pin or C17 Core Pin, use a CB17 Counterbore.

COUNTERBORES FOR EJECTOR PINS

ITEM NUMBER	EJ. PIN SIZE "G"	C-BORE BODY DIA.	PILOT LENGTH*	SHANK DIAMETER	OVERALL LENGTH
CB9	1/8(T)	17/64	3/16	1/4	2 5/8
CB10	9/64	17/64	3/16	1/4	2 5/8
CB11	5/32	19/64	3/16	1/4	2 3/4
CB12	11/64	23/64	3/16	1/4	3 1/16
CB13	3/16	25/64	3/16	3/8	3 1/4
CB14	13/64	25/64	3/16	3/8	3 1/4
CB15	7/32	27/64	1/4	3/8	3 3/8
CB16	15/64	27/64	1/4	3/8	3 3/8
CB17	1/4	29/64	1/4	7/16	3 9/16
CB18	17/64	29/64	1/4	7/16	3 9/16
CB19	9/32	29/64	1/4	7/16	3 9/16
CB20	19/64	33/64	5/16	1/2	3 7/8
CB21	5/16	33/64	5/16	1/2	3 7/8
CB22	21/64	37/64	5/16	1/2	4 1/8
CB23	11/32	37/64	5/16	1/2	4 1/8
CB24	23/64	41/64	5/16	5/8	4 1/2
CB25	3/8	41/64	5/16	5/8	4 1/2
CB27	13/32	45/64	5/16	5/8	4 3/4
CB29	7/16	49/64	5/16	5/8	4 3/4
CB31	15/32	49/64	5/16	5/8	5 1/8
CB33	1/2	49/64	5/16	5/8	5 1/8
CB35	9/16	53/64	5/16	5/8	5 3/8
CB37	5/8	57/64	5/16	5/8	5 5/8
CB39	11/16	61/64	5/16	5/8	5 7/8
CB41	3/4	1 1/64	5/16	5/8	6 1/4
CB45	7/8	1 9/64	5/16	3/4	6 1/4
CB47	1"	1 17/64	5/16	3/4	6 1/4

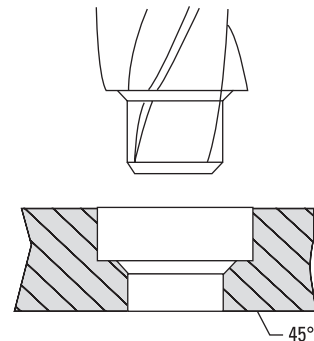

COUNTERBORES FOR JIFFY-TITE CONNECTORS

ITEM NUMBER	FOR USE WITH	C-BORE BODY DIA.	PILOT DIA.	SHANK DIA.	OVERALL LENGTH
CB80	JP251	1 1/16	.337	1/2	4 1/8
CB81	JP252(SV)	27/32	.435	5/8	4 3/4
CB82	JP253(SV) JP353(SV)	1.000	.575	5/8	5 5/8

(†) For EX3 through EX9 Ejector Pins, use Counterbore CB9.

*Pilot diameters are approximately .001 to .004 under EJ. Pin Size "G" diameter shown.

Machine Reamers



- Right Hand Spiral
- Right Hand Cut
- High Speed Steel
- Straight Shank

DME Machine Reamers are made of top quality High Speed Steel and are especially effective for use in materials which are ordinarily difficult to ream. The right-hand spiral and right-hand cut design gives them a free cutting action resulting in smooth, accurate holes.

MACHINE REAMERS FOR EJECTOR PIN HOLES

ITEM NUMBER*	NOMINAL DIAMETER	DIAMETER Decimal Size	SHANK DIAMETER	FLUTE LENGTH	OVERALL LENGTH
R5	1/16	.0625	.0585	1/2	2 1/2
R6	5/64	.078125	.0720	3/4	3
R7	3/32	.09375	.0880	3/4	3
R8	7/64	.109375	.1030	7/8	3 1/2
R9	1/8	.125	.1190	7/8	3 1/2
R9 OS	1/8	.130	.1190	7/8	3 1/2
R10	9/64	.140625	.1350	1	4
R11	5/32	.15625	.1510	1	4
R11 OS	5/32	.16125	.1510	1	4
R12	11/64	.171875	.1645	1 1/8	4 1/2
R13	3/16	.1875	.1805	1 1/8	4 1/2
R13 OS	3/16	.1925	.1805	1 1/8	4 1/2
R14	13/64	.203125	.1945	1 1/4	5
R15	7/32	.21875	.2075	1 1/4	5
R15 OS	7/32	.22375	.2075	1 1/4	5
R16	15/64	.234375	.2265	1 1/2	6
R17	1/4	.250	.2465	1 1/2	6
R17 OS	1/4	.255	.2465	1 1/2	6
R18	17/64	.265625	.2485	1 1/2	6
R19	9/32	.28125	.2485	1 1/2	6
R19 OS	9/32	.28625	.2485	1 1/2	6
R20	19/64	.296875	.2792	1 1/2	6
R21	5/16	.3125	.2792	1 1/2	6
R21 OS	5/16	.3175	.2792	1 1/2	6
R22	21/64	.328125	.2792	1 1/2	6
R23	11/32	.34375	.2792	1 1/2	6
R23 OS	11/32	.34875	.2792	1 1/2	6
R24	23/64	.359375	.3105	1 3/4	7
R25	3/8	.375	.3105	1 3/4	7
R25 OS	3/8	.380	.3105	1 3/4	7
R27	13/32	.40625	.3105	1 3/4	7
R27 OS	13/32	.41125	.3105	1 3/4	7
R29	7/16	.4375	.3730	1 3/4	7
R29 OS	7/16	.4425	.3730	1 3/4	7
R31	15/32	.46875	.3730	1 3/4	7
R31 OS	15/32	.47375	.3730	1 3/4	7
R33	1/2	.500	.4355	2	8
R33 OS	1/2	.505	.4355	2	8
R35	9/16	.5625	.4355	2	8
R37	5/8	.625	.5620	2 1/4	9
R39	11/16	.6875	.5620	2 1/4	9
R41	3/4	.750	.6245	2 1/2	9 1/2
R45	7/8	.875	.7495	2 5/8	10
R47	1"	1.000	.8745	2 3/4	10 1/2

Machine Reamer Item Number corresponds to Ejector Pin Item Number.

For example: For an EX17 Ejector Pin, order an R17 Machine Reamer.

(*) "OS" in the Item Number indicates the reamer is .005" oversize nearest fractional diameter.

The "OS" reamers are also available in carbide. See price list.

MACHINE REAMERS FOR CARTRIDGE HEATER HOLES

ITEM NUMBER	NOMINAL DIAMETER	DIAMETER Decimal Size	SHANK DIAMETER	FLUTE LENGTH	OVERALL LENGTH
LRS4	3/8	.375	.3105	1 1/4	20
LRS7	1/2	.500	.4355	2	20
LRS15	5/8	.625	.5620	2 1/4	24
LRS25	3/4	.750	.6245	2 1/2	24

Sprue Bushing Reamers

Sprue Bushing Reamers

HIGH SPEED STEEL, RIGHT HAND CUT, LEFT HAND SPIRAL



MACHINE REAMER FOR ROUGHING



HAND REAMER FOR FINISHING

MACHINE REAMERS		TAPER PER FT.*	DIA. SMALL END	DIA. LARGE END	SHANK DIA.	FLUTE LENGTH	HAND REAMERS	
ITEM NUMBER	NO. FLUTES						ITEM NUMBER	NO. FLUTES
SR50125	3	1/2	7/64	3/8	5/16	6"	SR50125H	4
SR50	3	1/2	13/64	5/8	1/2	10 1/2"	SR50H	6
SR75125	3	3/4	7/64	31/64	3/8	6"	SR75125H	4
SR75	3	3/4	13/64	7/8	5/8	10 1/4"	SR75H	6

*1/2 TAPER PER FOOT = 2°23'13" included angle.

3/4 TAPER PER FOOT = 3°34'47" included angle.

For optimum results, first step drill hole slightly under reamer size. Then use machine reamer followed by hand reamer.

Rout-A-Burr

Rout-A-Burr



"No shop should be without these sturdy, time-saving hand tools!"

DME Rout-A-Burrs are versatile deburring and deflashing tools for mold and die makers, machinists, sheet metal workers, plastics molders and die casters. The sturdy acetal handle with interchangeable blade holders and blades can be used to break sharp edges, deburr, deflash, scrape and scribe. "Telescoping" action allows the blade holder to extend 1½ to 5" from the handle and be securely locked at various lengths by a ball and ring detent.

A selection of high speed steel (HSS) and carbide blades are available for use on metals and plastics...edges, internal and external holes.

ROUT-A-BURR ASSEMBLY
ITEM NUMBER
RBHA3

Includes handle with removable end cap, blade holder (RBB) and three blades (one each of RBB10, B20 and B30)

BLADE HOLDER		BLADES		ITEM NUMBER BOX OF 10
ITEM NO.		DESCRIPTION		
<p>Blades with * may be installed two ways as shown below.</p>		HSS basic blade for steel and aluminum. Ideal for straight edges or holes.	RBB10	
		HSS for cast iron and brass. Rotates clockwise and counterclockwise.	RBB20	
		Carbide tipped "V" blade for sheet metal up to 1/8" thick. Also ideal for breaking sharp edges after milling or grinding operations.	RBB70	

HEAVY DUTY BLADE HOLDER		HEAVY DUTY BLADES		ITEM NUMBER BOX OF 10
ITEM NO.		DESCRIPTION		
RBE			HSS heavy-duty; longer version of RBB10.	RBE100
			HSS heavy-duty; longer version of RBB20.	RBE200
			HSS heavy-duty for straight edges, keyways, etc.	RBE350

Contour Roughing Services

Key Advantages of Contour Roughing

- Moldmakers can use this service to extend their in-house capacity, reduce lead time and focus on other high-value machining
- Consistent machining allowance throughout the surface of the cavity block provides even finishing without areas of heavy stock
- DME can provide customers with the CAM program to continue the work where DME left off, saving time and programming expense
- Contour roughing can be bundled with the option to stress-relieve cavity blocks and a custom mold base

[Find My Rep](#)

At the request of moldmakers, DME has begun to offer contour roughing services. DME can rough mill complex part shapes into mold plates, even for milling that requires large and deep cavities.

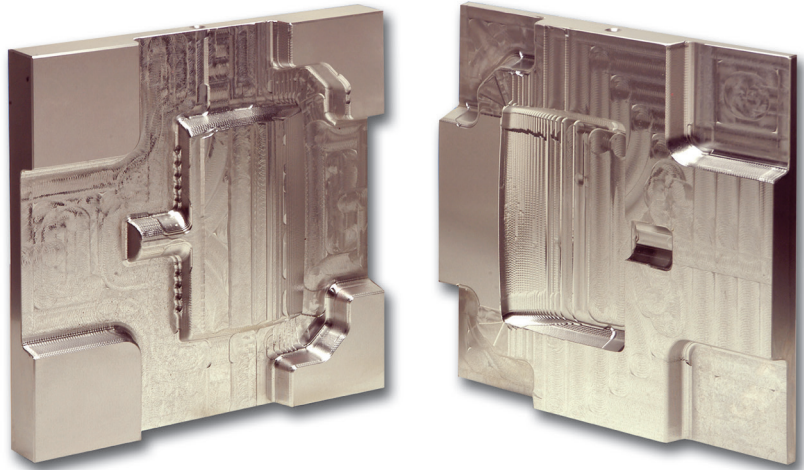

- The Contour Roughing Service begins with complex core and cavity CAD files from customers
- DME programs 3D cavity roughing tool paths that generate a rough milled surface, allowing machining stock for finishing by the customer
- DME uses industry-leading CAM software for programming contour roughing tool paths leaving consistent machining allowance throughout the surface of the cavity block

For more details on the Contour Roughing Service, contact your DME representative today.

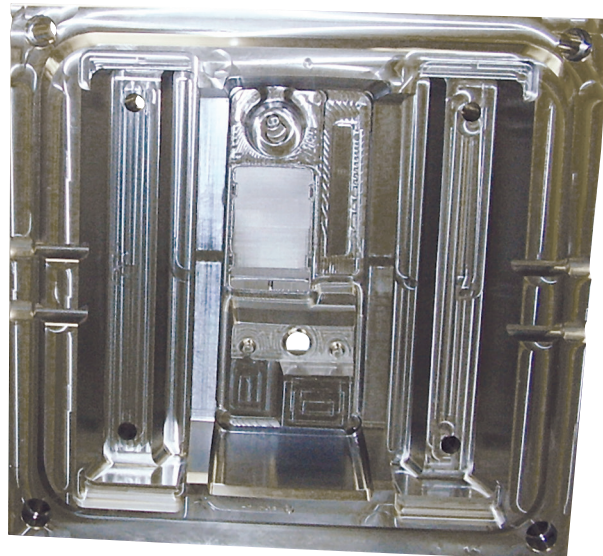

DME Finishing/Polishing Equipment

HUNDREDS OF EXACTING
FINISHING AND POLISHING
INSTRUMENTS AND SUPPLIES TO ACHIEVE
FLAWLESS FINISHES



Ultraform

FEATURES:

- Grinding can be completed quickly with 100W output or adjusted down for finish polishing
- Built-in LCD monitor indicates status of vibrations and the setting (including error status)
- Various polishing modes (hard/soft)
- Automatic power-off function ensures shut-down
- Output information memory
- Oscillator lowers power output if the tool generates heat so work can continue
- New "NANO mode" function provides ultra-fine amplitude control

Ultraform Polishing System



The ALL-AROUND SET

From rough grinding to ultra-fine polishing - this set can do it all!

PART NUMBER

UF0101AAS

Set includes:

OSCILLATORS & HANDPIECES	
UF0101	OSCILLATOR
UF9701	HANDPIECE
UF7401	HANDPIECE
ACCESSORIES	
UF7055	HANDPIECE CORD
UF7318	SPANNERS M12 & M14
UF7302	SPANNER M8
UF7305	SPANNER M10
UF7006	HEXAGONAL WRENCH M2.5
UF7003	HEXAGONAL WRENCH M3
UF7005	HEXAGONAL WRENCH M4
UF7015	TOOL EXTRACTOR M10 & M13
UF7101	POWER CORD 120V
UF7024	PROTECTOR SLEEVE SMALL (12 & 15 DIA. x 30l)
UF7502	HAND PIECE REST
UF7566	REPLACEMENT FUSE 3.15a / 120v

UF0101 Oscillator Specifications

Frequency	17-31 kHz automatic feedback
Maximum output	100W
Amplitude adjustment	99 steps
Power Supply	Single phase AC100 to 250V 50/60 Hz
Electricity consumption	300VA
Outer Dimensions	226w x 252d x 180h (mm)
Weight	5.2 kg

TOOLS	
MS0064	M6-M4 ADAPTOR
SE5745	DIAMOND FILE (FLAT-TAPERED, 0.8-0.3t x 4w, #320)
SE3803	DIAMOND FILE (TRIANGULAR, 3Δ)
SE8851	DIAMOND FILE (FLAT, 1t x 5w, #200)
SE8751	DIAMOND FILE (FLAT, 1t x 5w, #320)
SD4862	DIAMOND STONE (FLAT, 1.5t x 6w, #200)
SD4762	DIAMOND STONE (FLAT, 1.5t x 6w, #320)
NSP084F	SUPERSTONE (FLAT 0.8t x 4w x 40l, #600-BROWN)
NSB084F	SUPERSTONE (FLAT 0.8t x 4w x 40l, #800-BLUE)
NSP106F	SUPERSTONE (FLAT 1.0t x 6w x 40l, #600-BROWN)
NSP106F	SUPERSTONE (FLAT 1.0t x 6w x 40l, #800-BLUE)
NSPD3F	SUPERSTONE (ROUND 3.0 DIA. x 30L, #600-BROWN)
NSBD3F	SUPERSTONE (ORUND 3.0 DIA. x 30l, #800-BLUE_)
MX1030	TOOL CLAMP
MX2680	TOOL CLAMP
LD0762	DIAMOND STONE
LD0721	DIAMOND STONE
NSP212F	SUPERSTONE (FLAT,2t x 12w, #600-BROWN)
NSB212F	SUPERSTONE (FLAT, 2t x 12w, #800-BLUE)
LX4020	TOOL CLAMP

Ultraform

Ultraform Polishing System

The **TOUGH SET**Ideal for **BIG** jobs that need **POWER!**

PART NUMBER

UF0101TS



Set includes:

OSCILLATOR & HANDPIECES	
UF0101	OSCILLATOR
UF7401	HANDPIECE
TOOLS	
LD0762	DIAMOND STONE
LD0721	DIAMOND STONE
NSP212F	SUPERSTONE (FLAT, 2t x 12w, #600-BROWN)
NSB212F	SUPERSTONE (FLAT, 2t x 12w, #800-BLUE)
LX4020	TOOL CLAMP

ACCESSORIES

UF7055	HANDPIECE CORD
UF7318	SPANNERS M12 & M14
UF7005	HEXAGONAL WRENCH M4
UF7015	TOOL EXTRACTOR M10 & M13
UF7101	POWER CORD 120V
UF7024	PROTECTOR SLEEVE SMALL (12 & 15 DIA. x 30l)
UF7502	HAND PIECE REST
UF7566	REPLACEMENT FUSE 3.15A/ 120V

The **NANO SET**

Ideal for delicate polishing

PART NUMBER

UF0101NS



Set includes:

OSCILLATOR & HANDPIECES	
UF0101	OSCILLATOR
UF9701	HANDPIECE
ACCESSORIES	
UF7055	HANDPIECE CORD
UF7302	SPANNER M8
UF7305	SPANNER M10
UF7006	HEXAGONAL WRENCH M2.5
UF7003	HEXAGONAL WRENCH M3
UF7015	TOOL EXTRACTOR M10 & M13
UF7101	POWER CORD 120V
UF7024	PROTECTOR SLEEVE SMALL (12 & 15 DIA. x 30l)
UF7502	HAND PIECE REST
UF7566	REPLACEMENT FUSE 3.15a / 120v
TOOLS	
MS0064	M6-M4 ADAPTOR
SE5848	DIAMOND FILE (FLAT-TAPERED, 0.8-0.3t x 4w, #200)
SE5745	DIAMOND FILE (FLAT-TAPERED, 0.8-0.3t x 4w, #320)
SE6083	DIAMOND FILE (CONE-SHAPED, 3.0 DIA.)
SE3803	DIAMOND FILE (TRIANGULAR, 3Δ)

TOOLS (CONT)

SE8851	DIAMOND FILE (FLAT, 1t x 5w, #200)
SE8751	DIAMOND FILE (FLAT, 1t x 5w, #320)
SD4862	DIAMOND STONE (FLAT, 1.5t x 6w, #200)
SD4762	DIAMOND STONE (FLAT, 1.5t x 6w, #320)
NSP084F	SUPERSTONE (FLAT 0.8t x 4w x 40l, #600-BROWN)
NSB084F	SUPERSTONE (FLAT 0.8t x 4w x 40l, #800-BLUE)
NSP106F	SUPERSTONE (FLAT 1.0t x 6w x 40l, #600-BROWN)
NSP106F	SUPERSTONE (FLAT 1.0t x 6w x 40l, #800-BLUE)
NSPD3F	SUPERSTONE (ROUND 3.0 DIA. x 30L, #600-BROWN)
NSBD3F	SUPERSTONE (ORUND 3.0 DIA. x 30l, #800-BLUE_)
MX1030	TOOL CLAMP
MX2680	TOOL CLAMP
LD0762	DIAMOND STONE
LD0721	DIAMOND STONE
NSP212F	SUPERSTONE (FLAT, 2t x 12w, #600-BROWN)
NSB212F	SUPERSTONE (FLAT, 2t x 12w, #800-BLUE)
LX4020	TOOL CLAMP

Ultraform

Ultraform Polishing System

The DME Ultraform® Ultrasonic Finishing and Polishing Systems are designed to replace costly, time-consuming hand finishing operations. They excel at rapid deburring, filing, stoning, polishing and lapping on a variety of surfaces, including EDM, tungsten carbide, mold steels and more.

Using a continuously variable stroke of 4 to 40 microns (.00016 to .0016 inches) and ultrasonic vibrations of 20,000 cycles per second, these systems provide the ideal combination of pin-point control and heavy duty power. There is no need to adjust or “tune-in” the ultrasonic frequency for various replaceable tools. The Ultraform unit automatically adjusts the proper frequency for all size tools, including diamond files up to 6 inches long.

The UF5600, a dual system offering both Ultrasonic and Minitor functions which must be used independently.



The UF5600 systems include a universal hand piece that can be used with both large and small tooling. Each system is supplied with a variety of tools and all of the necessary accessories to handle your most intricate polishing jobs with ease.

IMPROVED FEATURES

DME's Ultraform model UF5600 offer the following improvements over previous systems:

- Added power increases tool cutting strength by 50%
- Improved circuitry provides constant power, regardless of the amount of pressure applied to the handpiece
- New transformer improves reliability
- Cool, vibration-free handpiece can be used with small and large tooling
- Clamp tool mode reduces power by 50%, preventing broken stones and burnt wood laps
- Power packs feature new updated cabinet styling and control panel layout
- 30% more torque when using rotary handpieces
- Universal handpiece is included with each system

HANDPIECE UF9700

Universal handpiece can be used with either system for large and small tooling. The UF9700 has a tool holder thread of 6mm, rather than the 8mm thread offered on previous handpieces. The handpiece and a 6-to-4mm adapter are included with both systems. All 8mm tooling will be replaced with 6mm to accommodate the new handpiece.

ULTRAFORM UF5600

Dual Operating Capabilities – Ultrasonic and Minitor functions.

Automatic Frequency Shift – Accommodates a broad range of tool sizes.

Tool Condition – The UF5600 calculates resonant frequencies and enables the operator to make customized tools. Reset switch activates if tool is too long or short.

Reversing Switch – Reverses rotation of handpiece for exact polishing of edges, corners, radii, etc.

State-of-the-art Circuitry – Improves torque at any RPM setting.

LED-Indicator Lights – Monitor power conditions and indicate operational modes.

User-Friendly Key Pad – Puts all functions within easy reach of operator.



Ultraform

Ultraform Accessories



STANDARD TOOLS AND ACCESSORIES INCLUDED WITH UF2600 AND UF5600:

4 – Diamond Files	5 – Tool Clamps	1 – Allen Key	1 – Plastic Toolbox
3 – Resin Bonded Diamond Stones	1 – Adapter: 6mm to 4mm Thread	1 – Replacement Fuse	2 – Protective Sleeves for the Handpiece
2 – Ea. of 6 Ceramic Stones	1 – Ultrasonic Handpiece	1 – Power Cord	1 – Wooden Case for the Handpiece
2 – Wooden Laps	4 – Wrenches: 8mm, (2) 10mm & 12mm	1 – Handpiece Rest	1 – Power Cord
3 – Diamond Stones		1 – Set of Protective Ear Plugs	

ITEM NUMBER	DESCRIPTION
UF5600	Power Module UF5600 and all standard tools and accessories
UF9700	Handpiece for UF2600 and UF5600 (included)

NOTE: If ordering other than standard 120 voltage, please specify.

Ultrasonic Handpiece UF9700 is included with UF5600 Ultraform Systems.

POWER MODULE SPECIFICATIONS	
Model	UF5600
Frequency of vibration	20.0 – 30.0 KHz
Amplitude (stroke)	4 to 40 microns (.00016 to .0016")
Frequency adjustment	Automatic feedback system
Power output ultrasonic	45 watts max.
Minitor power output (UF5600 only)	DC 0 – 30 volts
Output adjustment (power and stroke)	Continuously variable
Power requirement	Single phase 100 to 250 v 50/60 Hz
Power consumption	200 VA
Fuse	2 amperes 115 v 1.5 amperes 220 v
Outside dimension	6.5 × 11.2 × 8.4 in.
Net weight	8.2 lbs.

HANDPIECE UF9700 SPECIFICATIONS	
Transducer	B.L.T. electrostrictive
Cable length	2 feet (coiled)
Screw thread	6 and 4mm with adapter
Dimensions	Small dia. 0.6" Large dia. 1.12" Length 5.12"
Weight	4.55 ounces

ADDITIONAL TOOLING:

Additional tooling for the Ultraform Ultrasonic Finishing and Polishing System is available.

Refer to DME's ULTRAFORM ULTRASONIC TOOLING items for details.

Ultraform Tooling

Tooling Accessories in this item are for use with Ultraform Models UF2600, UF5600 and UF0101.

USAGE OF TOOLS

- All Ultraform tools are made to match the resonant frequency of Argofile UL501B and Ultraform models 2100/3000/5000/2600/5600/0101.
The manufacturer does not accept any liability for other manufacturers' tools.
- For maximum power, ensure all tools are securely fastened to the ultrasonic handpiece. Any noise coming from the joint between the tool and handpiece indicates an insecure fitting and/or bent tools, which result in reduced cutting power.
- Abrasive Stones/Ceramic Stones –
Ultraform models 2100/3000/5000/0101: When using SX, LX champ horns ensure power output does not exceed 3 on power indicator scale. Above this power level excessive heat will cause the bonding of the abrasive stone to break down.
Ultraform models 2600/5600: Operate only with clamp horn mode switch.
- Wooden Laps –
Ultraform models 2100/3000/5000/0101: When using wooden laps with SX, LX clamp horns ensure power output does not exceed 3 on power indicator scale. Above this power level excessive heat build-up will cause the wood to burn.
To obtain maximum driving power, retighten cap-screw on clamp horn during use.
Ultraform models 2600/5600: Operate only with clamp horn mode switch.

COLOR CODING

- All Ultraform diamond tools are color coded to identify the mesh/grit/micron (/UM) according to the chart below.

Color	MESH/GRIT	MICRON/UM
RED	200	68
BLACK	320	40
BLUE	500	35
WHITE	600	28
GREEN	1000	15

Ultraform Diamond Files

Ultraform Diamond Files

- Diamond particles are electro-deposited on steel shank
- Used for intermediate finishing
- Fast cutting

Precision graded particle size (68-28 micron).
Excellent for finishing slot sidewalls and flat or curved surfaces.

NOTE: All measurements in millimeters (mm).

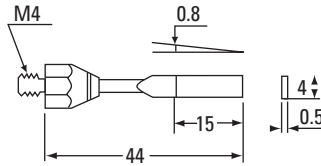

ITEM NUMBER	MESH/GRIT
USE5845	200
USE5745	320
USE5545	600

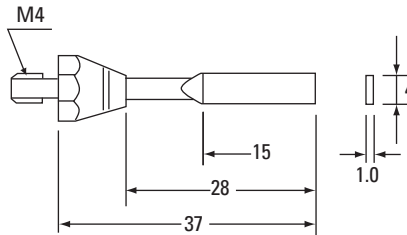

ITEM NUMBER	MESH/GRIT
SE4841	200
SE4741	320
SE4541	600

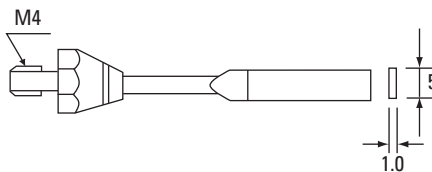

ITEM NUMBER	MESH/GRIT
SE8851U	200

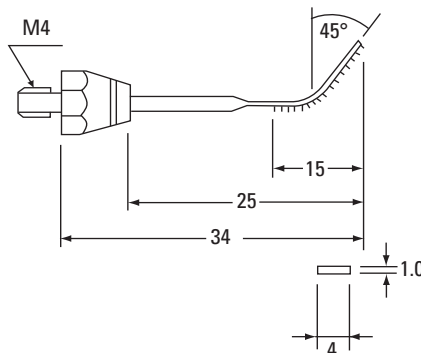

ITEM NUMBER	MESH/GRIT
SE7841	200
SE7741	320
SE7541	600

Ultraform Diamond Files

Ultraform Diamond Files

NOTE: All measurements in millimeters (mm).

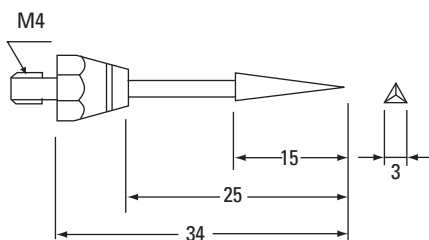

ITEM NUMBER	MESH/GRIT
SE3803	200
SE3703	320

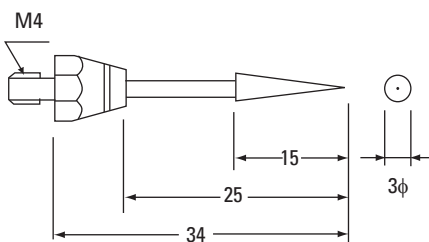

ITEM NUMBER	MESH/GRIT
SE6803	200
SE6703	320
SE6503	600

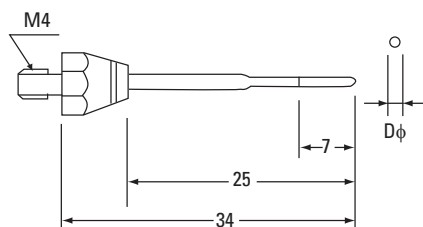

ITEM NUMBER	MESH/GRIT	D Ø
SE9502	600	2mm

Ultraform Diamond Files | Resin Bonded Diamond Stones

Ultraform Diamond Files

NOTE: All measurements in millimeters (mm).

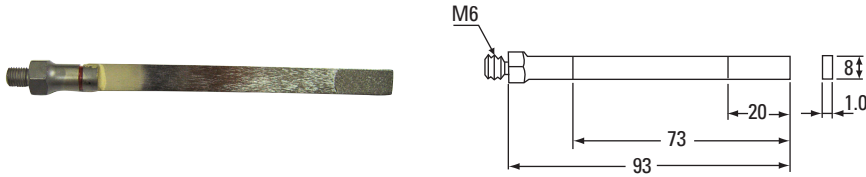

ITEM NUMBER	MESH/GRIT
UME9881	200
UME9781	320
UME9581	600

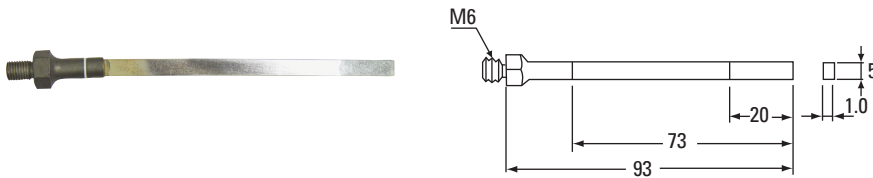

ITEM NUMBER	MESH/GRIT
UME9851	200
UME9751	320
UME9551	600

Resin Bonded Diamond Stones

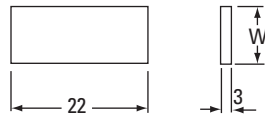
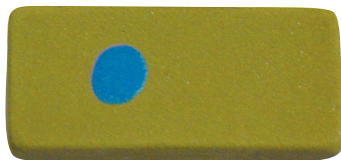

- Can be used on the ED surface
- 6W stones with tool clamp UMX4030
- 10 stones with tool clamp UMX4130

ITEM NUMBER	MESH/GRIT
UMD4372	1000
UMD4812	200
UMD4712	320
UMD4612	500
UMD4312	1000

Ultraform Diamond Stones

Ultraform Diamond Stones

- Solid stone of diamond particles in a metal bond
- Used for intermediate and fine finishing
- Precision graded particle size (68 ~ 15 micron)
- Can be shaped with a diamond file to finish intricate surfaces

NOTE: All measurements in millimeters (mm).

COLOR CODING: Red... #200, Black...#320, Blue...#500, Green...#1000

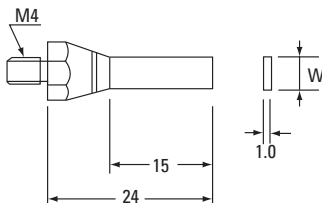
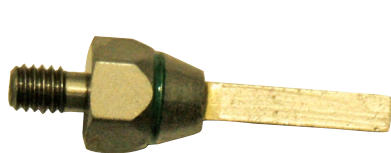

ITEM NUMBER	MESH/GRIT	W
SD4831	200	3.0
SD4731	320	3.0
SD4631	500	3.0
SD4331	1000	3.0
SD4851	200	5.0
SD4751	320	5.0
SD4651	500	5.0

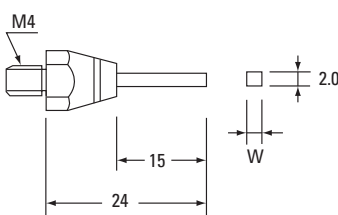
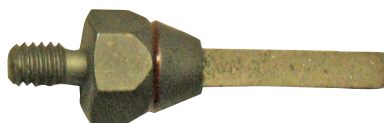

ITEM NUMBER	MESH/GRIT	W
SD2702	320	2.0
SD2302	1000	2.0

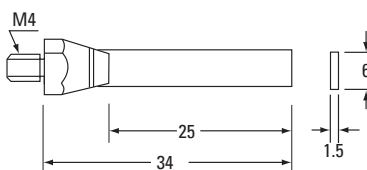

ITEM NUMBER	MESH/GRIT
SD4862	200
SD4762	320

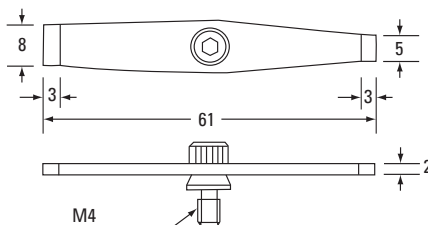
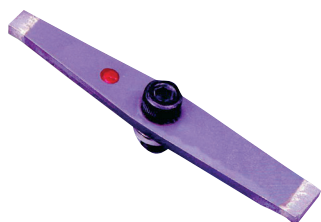

ITEM NUMBER	MESH/GRIT
USD7785	320
USD7685	500
USD7385	1000

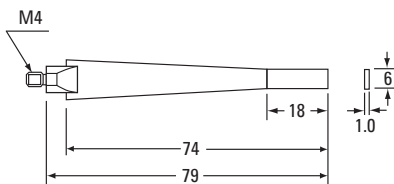

ITEM NUMBER	MESH/GRIT
USD5861	200
USD5761	320
USD5661	500
USD5361	1000

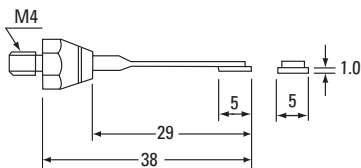

ITEM NUMBER	MESH/GRIT
SD4861	200
SD4761	320

Ultraform Diamond Stones

NOTE: All measurements in millimeters (mm).
 COLOR CODING: Red... #200, Black...#320, Blue...#500, Green...#1000

Ultraform Diamond Stones

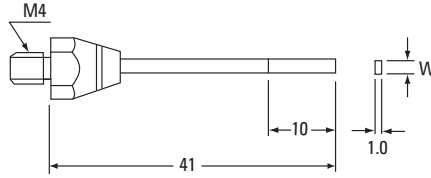

ITEM NUMBER	MESH/GRIT	W
SD5831	200	3.0
SD5731	320	3.0

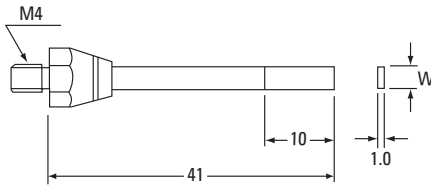

ITEM NUMBER	MESH/GRIT	W
SD5841	200	4.0
SD5741	320	4.0
SD5851	200	5.0
SD5751	320	5.0

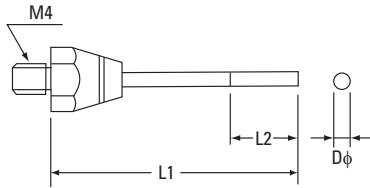

ITEM NUMBER	MESH /GRIT	L1	L2	D
SD1602	500	37	7.0	2.0
SD1803	200	39	10	3.0
SD1703	320	39	10	3.0

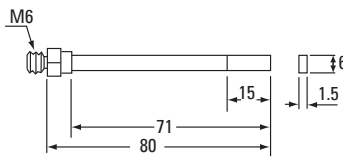

ITEM NUMBER	MESH/GRIT
UMD8862	200
UMD8762	320
UMD8662	500
UMD8362	1000



TAPER = 1.5 → 0.5t

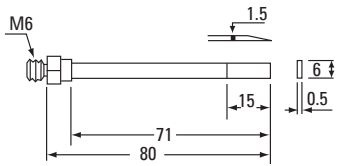

ITEM NUMBER	MESH/GRIT
UMD9865	200
UMD9765	320
UMD9665	500
UMD9365	1000

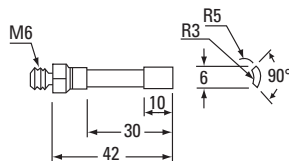

ITEM NUMBER	MESH/GRIT
UMD1325	1000

Super Stone Ceramic Stones

Super Stone Ceramic Stones

- Non-clogging; beautiful results on all types of metals in small and detailed area
- Available in flat and round profiles
- Incredible strength and flexibility, offering excellent polishability even under strenuous conditions
- Grits 120 to 1200, easily identifiable by color

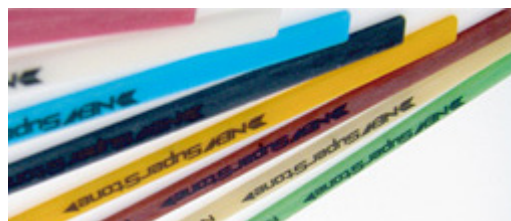

COLOR	MESH/GRIT
EMERALD	120
GOLD	180
LIGHT BROWN	300
ORANGE	400
BROWN	600
BLUE	800
WHITE	1000
RED	1200

FLAT TYPE

DIMENSIONS T x W x L (mm)	EMERALD 120#	GOLD 180#	LT BROWN 300#	ORANGE 400#	BROWN 600#	BLUE 800#	WHITE 1000#	RED 1200#
0.5 x 1 x 100	NSE0501	NSG0501	NSL0501	NSO0501	NSP0501	NSB0501	NSW0501	NSR0501
0.5 x 2 x 100	NSE052	NSG052	NSL052	NSO052	NSP052	NSB052	NSW052	NSR052
0.5 x 4 x 100	NSE054	NSG054	NSL054	NSO054	NSP054	NSB054	NSW054	NSR054
0.5 x 6 x 100	NSE056	NSG056	NSL056	NSO056	NSP056	NSB056	NSW056	NSR056
0.5 x 10 x 100	NSE051	NSG051	NSL051	NSO051	NSP051	NSB051	NSW051	NSR051
0.8 x 1 x 100	NSE0801	NSG0801	NSL0801	NSO0801	NSP0801	NSB0801	NSW0801	NSR0801
0.8 x 2 x 100	NSE082	NSG082	NSL082	NSO082	NSP082	NSB082	NSW082	NSR082
0.8 x 4 x 100	NSE084	NSG084	NSL084	NSO084	NSP084	NSB084	NSW084	NSR084
0.8 x 6 x 100	NSE086	NSG086	NSL086	NSO086	NSP086	NSB086	NSW086	NSR086
0.8 x 10 x 100	NSE081	NSG081	NSL081	NSO081	NSP081	NSB081	NSW081	NSR081
1.0 x 1 x 100	NSE101	NSG101	NSL101	NSO101	NSP101	NSB101	NSW101	NSR101
1.0 x 2 x 100	NSE102	NSG102	NSL102	NSO102	NSP102	NSB102	NSW102	NSR102
1.0 x 4 x 100	NSE104	NSG104	NSL104	NSO104	NSP104	NSB104	NSW104	NSR104
1.0 x 6 x 100	NSE106	NSG106	NSL106	NSO106	NSP106	NSB106	NSW106	NSR106
1.0 x 10 x 100	NSE110	NSG110	NSL110	NSO110	NSP110	NSB110	NSW110	NSR110
1.5 x 1 x 100	NSE151	NSG151	NSL151	NSO151	NSP151	NSB151	NSW151	NSR151
1.5 x 2 x 100	NSE152	NSG152	NSL152	NSO152	NSP152	NSB152	NSW152	NSR152
1.5 x 4 x 100	NSE154	NSG154	NSL154	NSO154	NSP154	NSB154	NSW154	NSR154
1.5 x 6 x 100	NSE156	NSG156	NSL156	NSO156	NSP156	NSB156	NSW156	NSR156
1.5 x 10 x 100	NSE150	NSG150	NSL150	NSO150	NSP150	NSB150	NSW150	NSR150
2.0 x 2 x 100	NSE202	NSG202	NSL202	NSO202	NSP202	NSB202	NSW202	NSR202
2.0 x 4 x 100	NSE204	NSG204	NSL204	NSO204	NSP204	NSB204	NSW204	NSR204
2.0 x 6 x 100	NSE206	NSG206	NSL206	NSO206	NSP206	NSB206	NSW206	NSR206
2.0 x 10 x 100	NSE210	NSG210	NSL210	NSO210	NSP210	NSB210	NSW210	NSR210
3.0 x 1 x 100	NSE301	NSG301	NSL301	NSO301	NSP301	NSB301	NSW301	NSR301
3.0 x 2 x 100	NSE302	NSG302	NSL302	NSO302	NSP302	NSB302	NSW302	NSR302
3.0 x 4 x 100	NSE304	NSG304	NSL304	NSO304	NSP304	NSB304	NSW304	NSR304
3.0 x 6 x 100	NSE306	NSG306	NSL306	NSO306	NSP306	NSB306	NSW306	NSR306
3.0 x 10 x 100	NSE310	NSG310	NSL310	NSO310	NSP310	NSB310	NSW310	NSR310

Super Stone Ceramic Stones

Super Stone Ceramic Stones

- Non-clogging; beautiful results on all types of metals in small and detailed area
- Available in flat and round profiles
- Incredible strength and flexibility, offering excellent polishability even under strenuous conditions
- Grits 120 to 1200, easily identifiable by color

COLOR	MESH/GRIT
EMERALD	120
GOLD	180
LIGHT BROWN	300
ORANGE	400
BROWN	600
BLUE	800
WHITE	1000
RED	1200

ROUND TYPE

DIMENSIONS Ø D x L (mm)	EMERALD 120#	GOLD 180#	LT BROWN 300#	ORANGE 400#	BROWN 600#	BLUE 800#	WHITE 1000#	RED 1200#
Ø 2.35 x 50	NSED23A	NSGD23A	NSLD23A	NSOD23A	NSPD23A	NSBD23A	NSWD23A	NSRD23A
Ø 2.35 x 100	NSED23B	NSGD23B	NSLD23B	NSOD23B	NSPD23B	NSBD23B	NSWD23B	NSRD23B
Ø 2.35 x 150	NSED23L	NSGD23L	NSLD23L	NSOD23L	NSPD23L	NSBD23L	NSWD23L	NSRD23L
Ø 3.0 x 50	NSED3A	NSGD3A	NSLD3A	NSOD3A	NSPD3A	NSBD3A	NSWD3A	NSRD3A
Ø 3.0 x 100	NSED3B	NSGD3B	NSLD3B	NSOD3B	NSPD3B	NSBD3B	NSWD3B	NSRD3B
Ø 3.0 x 150	NSED3L	NSGD3L	NSLD3L	NSOD3L	NSPD3L	NSBD3L	NSWD3L	NSRD3L
Ø 3.175 x 50	NSEDIA	NSGDIA	NSLDIA	NSODIA	NSPDIA	NSBDIA	NSWDIA	NSRDIA
Ø 3.175 x 100	NSEDIB	NSGDIB	NSLDIB	NSODIB	NSPDIB	NSBD1B	NSWDIB	NSRDIB
Ø 3.175 x 150	NSEDIL	NSGDIL	NSLDIL	NSODIL	NSPD1L	NSBD1L	NSWDIL	NSRDIL

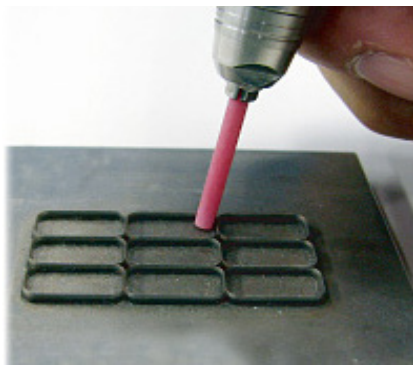

Ultraform Tool Clamps (Clamp Horns)

Ultraform Tool Clamps (Clamp Horns)

NOTE: All measurements in millimeters (mm).

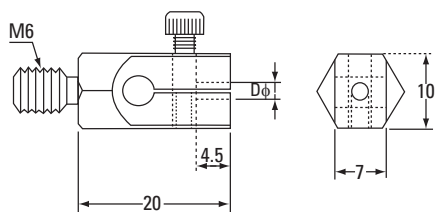

ITEM NUMBER	D
UMX1020	2.0
UMX1030	3.0
UMX1033	3.3

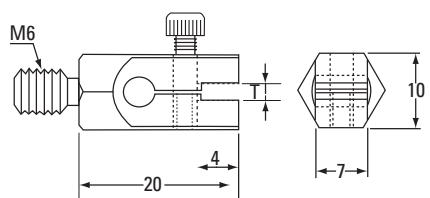

ITEM NUMBER	T
UMX4008	0.8
UMX4010	1.0
UMX4020	2.0
UMX4030	3.0
UMX4033	3.3

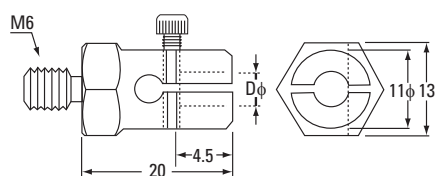

ITEM NUMBER	D
UMX1140	4.0
UMX1150	5.0
UMX1160	6.0

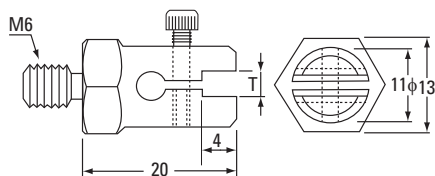

ITEM NUMBER	T
UMX4110	1.0
UMX4120	2.0
UMX4130	3.0
UMX4133	3.3
UMX4140	4.0
UMX4150	5.0

Ultraform Adapters

Ultraform Adapters

NOTE: All measurements in millimeters (mm).

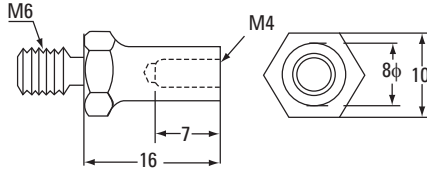

ITEM
NUMBER
UMS0064

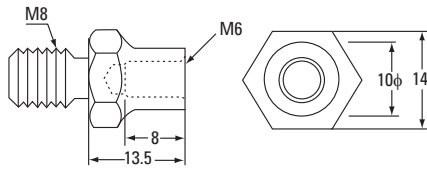

ITEM
NUMBER
UMS0086

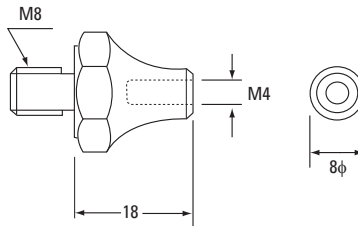

ITEM
NUMBER
SL1000

Ultraform Accessories

Ultraform Accessories

HANDPIECE
UF9700



CLAMP HORN KEY
UF7005 M4



PROTECTION SLEEVE

- 1) UF7024
- 2) UF7026
- 3) UF7025

**SPECIAL
ORDER ONLY**

WOODEN CASE FOR HANDPIECE
UF7017 for UF9000, UF9700

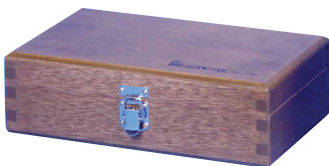

PLASTIC TOOL BOX
UF7022



POWER CORD
UF7101 115V U.S.A.

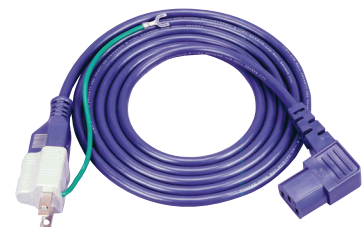

Maxima EX Controller | Accessories

Controller Built-in microcomputer control enables smooth operation by controlling the torque for each handpiece

- Self-diagnostic function checks the motor and controller for safety issues
- 8-step load indicator allows operator to gauge tool condition and provides caution for longer life
- Digital display for easy rotation speed adjustment
- Auto cruise foot pedal can be used to set rotation speed for continued use
- Mode selection function enables controller to automatically find motor on A or B
- Adjustable volume control signals rotation speed



Maxima Polishing System

ITEM NUMBER	DESCRIPTION
MEX120	50/60Hz SINGLE PHASE , AC 120V
MEX230	50/60Hz SINGLE PHASE , AC 230V

NOTE: Maxima ex Series controller will accept Minitor "D" Handpieces with use of adaptor. Rotation speed will not be indicated on the digital display.

Accessories



ITEM NUMBER

MTRC02

HANDPIECE CRADLE MODEL MTRC02

This molded rubber stand provides a handy non-slip place to "park" any handpiece when not in use. The functional stand is an ideal way to keep your bench top neat, and your handpieces accessible.



ITEM NUMBER

MKE50154

REPLACEMENT HANDPIECE CORD MODEL MKE50154

This straight coiled cord is designed to connect between the handpiece and controller. 1.5 meters



ITEM NUMBER

MVC90

SPEED PEDAL FOOT CONTROL MODEL MVC90

The Foot Control Pedal comes with a fixed rotation option. After setting the speed your foot can be removed from the pedal. For use with new Maxima ex Series Power Pack only.



HANDPIECE ADAPTOR MODEL MKE50-156

The new Maxima handpieces can be used with the Minitor D Series Powerpack but the handpiece adaptor is required.

ITEM NUMBER

MKE50-156

ITEM NUMBER

MMC15536

HANDPIECE MOTOR HANGER MODEL MMC15536

Hanger mounts to the side of the controller and holds the handpiece when not in use



HAND PIECE EXTENSION CORD (not shown) Flexible 3-meter coiled cord connects between any Maxima handpiece and Controller or Ultraform UF5600. **ITEM NUMBER: MKE50155**

Maxima EX Series Rotary Handpieces

Maxima Polishing System

Rotary Handpieces

MODELS MEX201, MEX211, MEX121, MEX231, MEX131, MEX051

All handpieces are 2-piece construction with a detachable head. New slim line rotary handpieces are perfectly balanced for ease of handling in even the most difficult jobs. The MEX201 provides super torque for heavy duty applications, while the MEX051 with its speed of 55,000 RPM is ideal for carbide burrs, CBN and diamond tools.

- Quick release 2.35 mm and 3.0 mm collets for rapid tool changing
- Straight cord plug-in for quick replacement (no screws or soldering required)
- Range of 8,000 to 55,000 rpm

ITEM NUMBER
MEX201

Super Torque

Rated Input Voltage0-30 D.C.V.
 Rotation Speed..... 1,000-8,000 rpm
 Max Shaft Output..... 22.3 W
 Max Shaft Torque.....9.8 N/cm
 Size.....31.5 x 175.8 mm
 Overall Weight276 g
 Motor (MEX20) Weight.....176 g

ITEM NUMBER
MEX211

High Torque

Rated Input Voltage0-30 D.C.V.
 Rotation Speed..... 1,000-15,000 rpm
 Max Shaft Output..... 38.9 W
 Max Shaft Torque..... 8.8 N/cm.
 Size.....31.5 x 175.8 mm
 Overall Weight276 g
 Motor (MEX21) Weight.....176 g

ITEM NUMBER
MEX121

High Torque

Rated Input Voltage0-30 D.C.V.
 Rotation Speed..... 1,000-20,000 rpm
 Max Shaft Output.....32.4 W
 Max Shaft Torque.....6.4 N/cm.
 Size.....27.5 x 163.5 mm
 Overall Weight220 g
 Motor (MEX 12) Weight.....120 g



ITEM NUMBER
MEX231

All-Arounder

Rated Input Voltage0-30 D.C.V.
 Rotation Speed..... 1,000-30,000 rpm
 Max Shaft Output.....56.4 W
 Max Shaft Torque.....6.8 N/cm
 Size.....31.5 x 175.8 mm
 Overall Weight276 g
 Motor (MEX23) Weight.....176 g

ITEM NUMBER
MEX131

All-Arounder

Rated Input Voltage0-30 D.C.V.
 Rotation Speed..... 1,000-35,000 rpm
 Max Shaft Output..... 50.5 W
 Max Shaft Torque.....5.4 N/cm.
 Size.....27.5 x 163.5 mm
 Overall Weight220 g
 Motor (MEX13) Weight.....120 g

ITEM NUMBER
MEX051

High Speed

Rated Input Voltage0-30 D.C.V.
 Rotation Speed..... 1,000-55,000 rpm
 Max Shaft Output..... 45.2 W
 Max Shaft Torque.....3.6 N/cm.
 Size.....27.5 x 153.0 mm
 Overall Weight190 g
 Motor (MEX05) Weight.....90 g



*Standard Head MJA15 comes with all handpieces.

Note: Due to improved design, "D" Series motors and heads are not interchangeable with previous models.

Maxima EX Series Motors | Accessory Heads

Maxima Polishing System

ITEM NUMBER	DESCRIPTION
MEX20	1,000 ~ 8,000 RPM / TORQUE OUTPUT 9.8N/CM
MEX21	1,000 ~ 15,000 RPM / TORQUE OUTPUT 8.8N/CM
MEX12	1,000 ~ 20,000 RPM / TORQUE OUTPUT 6.4N/CM
MEX23	1,000 ~ 30,000 RPM / TORQUE OUTPUT 6.8N/CM
MEX13	1,000 ~ 35,000 RPM / TORQUE OUTPUT 5.4N/CM
MEX05	2,000 ~ 55,000 RPM / TORQUE OUTPUT 3.6N/CM



NOTE: Due to improved design, "D" series motors and heads are not interchangeable with previous models.

Accessory Heads

STANDARD HEAD

MODEL MJA15

Standard collet sizes: 2.35 mm and 3.175 mm
Special collet size: 3.0 mm
Use with motors: MEX23, MEX21, MEX20
Weight: 100 g

ITEM NUMBER

MJA15



ITEM NUMBER

MJA33

HEAVY-DUTY HEAD

MODEL MJA33

Standard collet size: 6.35 mm
Special collet sizes: 3.0 or 6.0 mm
Use with motors: MEX23, MEX21, MEX20
Weight: 150 g

SLENDER HEAD

MODEL MJA45

Standard collet size: 3.175 mm
Special collet sizes: 2.35 or 3.0 mm
Use with motors: MEX23, MEX21, MEX20
Weight: 120 g

ITEM NUMBER

MJA45

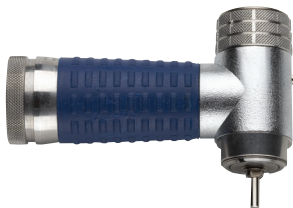

ITEM NUMBER

MJR21

90° ANGLE HEAD

MODEL MJR21

Standard collet size: 3.0 mm and 3.175 mm
Special collet sizes: 2.35 mm
Use with motors: MEX21, MEX20
Weight: 200 g

Belt Sander | Profiler R

Belt Sander

MODEL UFHBS33

- Direct motor drive provides maximum power
- Spring loaded tensioning device on belt arm enables quick change of sanding belts
- Lubrication not required

ABRASIVE BELTS

WIDTH	GRIT	ITEM NUMBER*
¼ (6mm)	80	ABB08080
	120	ABB08120
	180	ABB08180
⅝ (8mm)	80	ABB10080
	120	ABB10120
	180	ABB10180
	240	ABB10240

*Pack of 10



ITEM NUMBER
UFHBS33

SPECIFICATIONS

UFHBS33
 Input Voltage 0-30 D.C.V.
 Rated Amperage 0.3 D.C.A.
 Belt Speed 3 to 12 m/sec.
 Weight 450g

Profiler "R"

MODELS NMS0005 AND NMS0006

- Pistol grip provides comfort and easy handling
- Curl cord enables freedom of movement for greater accuracy
- Variable speed control and stroke adjustment provides maximum flexibility
- Accepts tool shanks up to ⅜" max



SPECIFICATIONS

NMS0005
 Rated Input Voltage 0-30 D.C.V.
 Reciprocating Stroke 0-6mm
 Frequency 0-4,200 strokes/min
 Rotation Speed 15,000 rpm
 Pulley Reduction Rate 1:3.4
 Size 145mm (L) × 40mm (W) × 130mm (H)
 Weight 675g

ITEM NUMBER
NMS0005

NMS0006
 Rated Input Voltage 0-30 D.C.V.
 Reciprocating Stroke 0-2mm
 Frequency 0-7,000 strokes/min
 Rotation Speed 15,000 rpm
 Pulley Reduction Rate 1:2
 Size 145mm (L) × 40mm (W) × 130mm (H)
 Weight 675g

ITEM NUMBER
NMS0006













Steel Files | Diamond Files

Steel Files

SWISS PATTERN

Precision-cut and made of high-quality steel. All are available in either "00" or "01" cut and have 1/8 shanks.



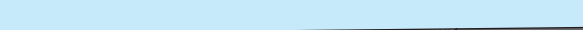

















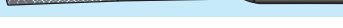

ITEM NUMBER	CUT
STL00SET	00
STL01SET	01

STEEL FILES (STL101 – 4" LONG, ALL OTHERS 3 1/2" LONG)		SHAPE	DESCRIPTION	ITEM NUMBER
		Flat	.400 wide x .110 thick	STL101-*
		Flat	.200 wide x .060 thick	STL1-*
		Round	.045 to .125 dia.	STL2-*
		Half Round	.125 to .180 wide .045 to .100 thick	STL3-*
		Crossing	.100 to .180 wide .045 to .075 thick	STL4-*
		Triangular	.070 to .125 per side	STL5-*
		Square	.045 to .100 per side	STL6-*

*When ordering files above, add "00" or "01" to end of item number to indicate cut desired (e.g. STL100).

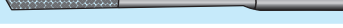
Diamond Files

DME diamond files are particularly adapted for cavity finishing. Diamond particles are accurately graded and then metal bonded with points exposed. All DME diamond files are supplied with 1/8 shanks. Heavy black lines on end cross sections indicate cutting edges.

























STANDARD DIAMOND FILES (2" LONG)		SHAPE	DESCRIPTION**	ITEM NUMBER
		Flat	.0787 wide x .046 thick	DLA2x1
			.1181 wide x .046 thick	DLA3x1
			.1575 wide x .046 thick	DLA4x1
			.1575 wide x .0787 thick	DLA4x2
			.1969 wide x .0787 thick	DLA5x2
		Round	.046 diameter	DLA1
			.0787 diameter	DLA2
			.1181 diameter	DLA3
		Triangular	.0787 x .0787 x .0787	DLAT2
			.1181 x .1181 x .1181	DLAT3
		Crossing	.1610 wide x .0722 thick	DLAR2.5xR5
LONG DIAMOND FILE (3 1/4" LONG)			**100 MICRONS	
		Flat	.1969 wide x .0600 thick	DLE1

Half Rifflers | Felt Bobs

Half Rifflers

FOR USE WITH MINITOR PROFILER 'R'

The half rifflers illustrated below are precision-cut swiss pattern ruffle files made of high-quality steel. DME half rifflers are available in a variety of shapes. All are available in either "0" or "2" cut, have 1/8 shanks and are 3 1/2" long.

	ITEM NUMBER PREFIX*		ITEM NUMBER PREFIX*
	HR557		
	HR558		
	HR559		
	HR560		
	HR561		
			
			
			
			
			
			
			
			
			
			

*When ordering half rifflers above, add "0" or "2" to end of item number to indicate cut desired (e.g. HR5560).

Felt Bobs

FOR USE WITH MINITOR PROFILER 'R'

- 45° angle end cut
- 1/8" diameter x 1 1/4" long shanks

SIZE	MEDIUM	HARD	ROCK HARD
	ITEM NUMBER	ITEM NUMBER	ITEM NUMBER
1/4 x 1/4 x 1 1/2	LSB1M	LSB1H	LSB1DH
3/8 x 3/8 x 1 1/4	LSB2M	LSB2H	LSB2DH
1/2 x 1/2 x 1 3/4	LSB3M	LSB3H	LSB3DH



Abrasive Stone Holders

Abrasive Stone Holders

- Handheld and shank-mounted styles
- Provide excellent control and quick stone changes

The new line of abrasive stone holders provides the metal finisher with excellent control and convenience. They are precision molded of shock absorbing, impact resistant nylon 6-6, and feature a removable collar that locks the stones in place and permits quick stone changes. Shank mounted style is designed for use with the Minitor *Profiler 'R' as well as other reciprocating profilers.

Handheld style offers double end capacity.

* (1/8 shanks only)



HSH400



SH210



SH220



SH310



SH320

ABRASIVE STONE HOLDERS

ITEM NUMBER	SHANK DIAMETER	ACCOMMODATES STONE SIZE
SH210	(1/8) .125	1/8 x 1/4
SH220	(1/8) .125	1/8 x 1/2 1/4 x 1/4
SH310	(3/16) .185	1/8 x 1/4
SH320	(3/16) .185	1/8 x 1/2 1/4 x 1/4
HSH400 (Handheld Stone Holder)	None	1/16 x 1/2 1/8 x 1/2 1/4 x 1/4 1/8 x 1/4

Abrasive Stones

Abrasive Stones

The stones are sized for use with DME Stone Holders. They are available in three types of stones: VITRIFIED for general purpose finishing, RESIN for finishing EDM surfaces and ALUMINUM OXIDE

for polishing. DME abrasive stones can be used on pre-hardened, hardened and soft mold and die steels.



LENGTH (ALL STONES = 4")		GENERAL PURPOSE				EDM			FINE FINISH	
		SILICON-CARBIDE VITRIFIED BONDED TYPE V				SILICON-CARBIDE RESIN BONDED TYPE R			ALUMINUM OXIDE TYPE X	
THICKNESS	WIDTH	GRIT				GRIT			GRIT	
		150	240	400	600	120	220	320	600	900
1/8	3/8	•	•	•	•	•	•	•	•	•
3/16	3/8	•	•	•	•	•	•	•	–	–
1/4	3/8	•	•	•	•	•	•	•	–	–
1/8	1/2	•	•	•	•	•	•	•	–	–
3/16	1/2	•	•	•	•	•	•	•	–	–
1/4	1/2	•	•	•	•	•	•	•	•	•
3/8	1/2	•	•	•	•	•	•	•	•	•

WHEN ORDERING, PLEASE SPECIFY:
 1. Quantity
 2. Thickness, width, length, grit and type
 Example: 316124220R

For other shapes and sizes of abrasive stones, see page 50.

Air Grinder and Filter Lubricator | Tungsten Carbide Rotary Cutters

Air Grinder and Filter Lubricator

The compact DME Air Grinder has a rated capacity of 1/4" diameter mounted points with its 1/8" collet. An easily operated speed adjusting throttle in the handpiece precisely controls the ball bearing motor to provide spindle speeds up to 60,000 rpm. The overhose exhaust, an integral part of the air supply line, muffles excessive noise and redirects the exhaust air away from the operator and work area. For added operator comfort, the metal handpiece is insulated by a plastic sleeve.

The DME Air Grinder Kit, packaged in a sturdy tool box, includes handpiece with 1/8" collet and nose guard, 5-foot air supply line with 2-foot overhose exhaust, and two wrenches. A metric version of the DME Air Grinder Kit is also available with a 3mm collet.

The recommended filter lubricator for air filtration and automatic lubrication is available separately.

AIR GRINDER KITS

(Motor = 0.1 hp)

ITEM NUMBER
AGK61
AGK61M*

Air Consumption = 0.7 cfm
*has 3mm collet



Tungsten Carbide Rotary Cutters

1/8, 1/4 AND 3/8 DIAMETERS

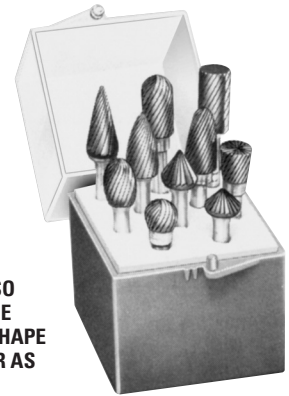

ROTARY CUTTERS ALSO AVAILABLE IN 10-PIECE SETS (ONE OF EACH SHAPE IN HANDY CONTAINER AS SHOWN)

DESCRIPTION	1/8" SOLID CARBIDE	1/4" CARBIDE HEADS ON 1/8" STEEL SHANKS	3/8" CARBIDE HEADS ON 1/4" STEEL SHANKS
	ITEM NUMBER	ITEM NUMBER	ITEM NUMBER
CYLINDRICAL	CYL1	CYL2	CYL3
CONE	CON1	CON2	
OVAL	OVL1	OVL2	
INVERTED CONE	INC1	INC2	INC3
BALL	BAL1	BAL2	BAL3
CYL. BALL END	CBE1	CBE2	CBE3
TREE SHAPE	TRS1	TRS2	TRS3
POINTED OVAL	POV1	POV2	POV3
60° CENTER	60C1	60C2	60C3
90° CENTER	90C1	90C2	90C3

CARBIDE CUTTER SETS (10 Cutters)

ITEM NUMBER	CUTTER HEAD DIA.
18CARBIDASET	1/8"
14CARBIDASET	1/4"
38CARBIDASET	3/8"

Mounted Points

Mounted Points

ALUMINUM OXIDE ABRASIVE VITRIFIED BOND

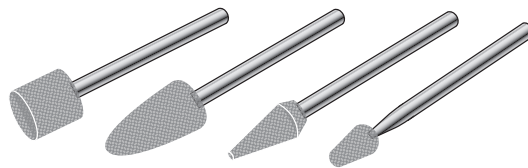

DME Mounted Points are carefully molded from the finest Aluminum Oxide Abrasive and with the exact amounts of Vitrified Bond to give the optimum holding qualities for the size of the point. They are precision formed to size and shape AFTER mounting to ensure concentricity between the point and the shank. This eliminates the vibration that causes

excessive wear and damage to both the tools and the work surface. This also reduces the danger of shattering points.

Five mounted points of same shape conveniently pre-packaged.

GROUP "B" SHAPES (1/8 SHANK)

ITEM NUMBER (PACK OF 5)	SIZE		
	DIA.	THICKNESS	GRIT
B41	5/8	5/8	60
B44	7/32	3/8	90
B45	3/16	5/16	90
B46	1/8	5/16	90
B47	1/8	5/32	60
B51	7/16	3/4	60
B52	3/8	3/4	60
B53	1/4	5/8	90
B55	1/8	1/4	90
B73	1/2	1/8	120
B81	3/4	3/16	90
B91	1/2	5/8	90
B96	1/8	1/4	90
B97	1/8	3/8	90
B98	3/32	1/4	90
B121	1/2	1/2	60
B122	3/8	3/8	60
B123	3/16	3/16	90
B124	1/8	1/8	90
B131	1/2	1/2	60
B132	3/8	1/2	60
B133	3/8	3/8	60
B134	5/16	3/8	60
B135	1/4	1/2	60
B136	1/4	5/16	90

GROUP "W" SHAPES (1/8 SHANK)

ITEM NUMBER (PACK OF 5)	SIZE		
	D DIA.	T THICKNESS	GRIT
W142	3/32	1/4	90
W143	1/8	1/8	90
W144	1/8	1/4	90
W146	1/8	1/2	90
W152	3/16	1/4	90
W153	3/16	3/8	90
W160	1/4	1/4	60
W161	1/4	5/16	60
W162	1/4	3/8	60
W163	1/4	1/2	60
W170	5/16	1/2	60
W173	3/8	1/8	60
W175	3/8	3/8	60
W176	3/8	1/2	60
W182	1/2	1/8	90
W185	1/2	1/2	60
W200	3/4	1/8	60
W215	1"	1/8	60
W216	1"	1/4	60

Mounted Points

GROUP "B" SHAPES

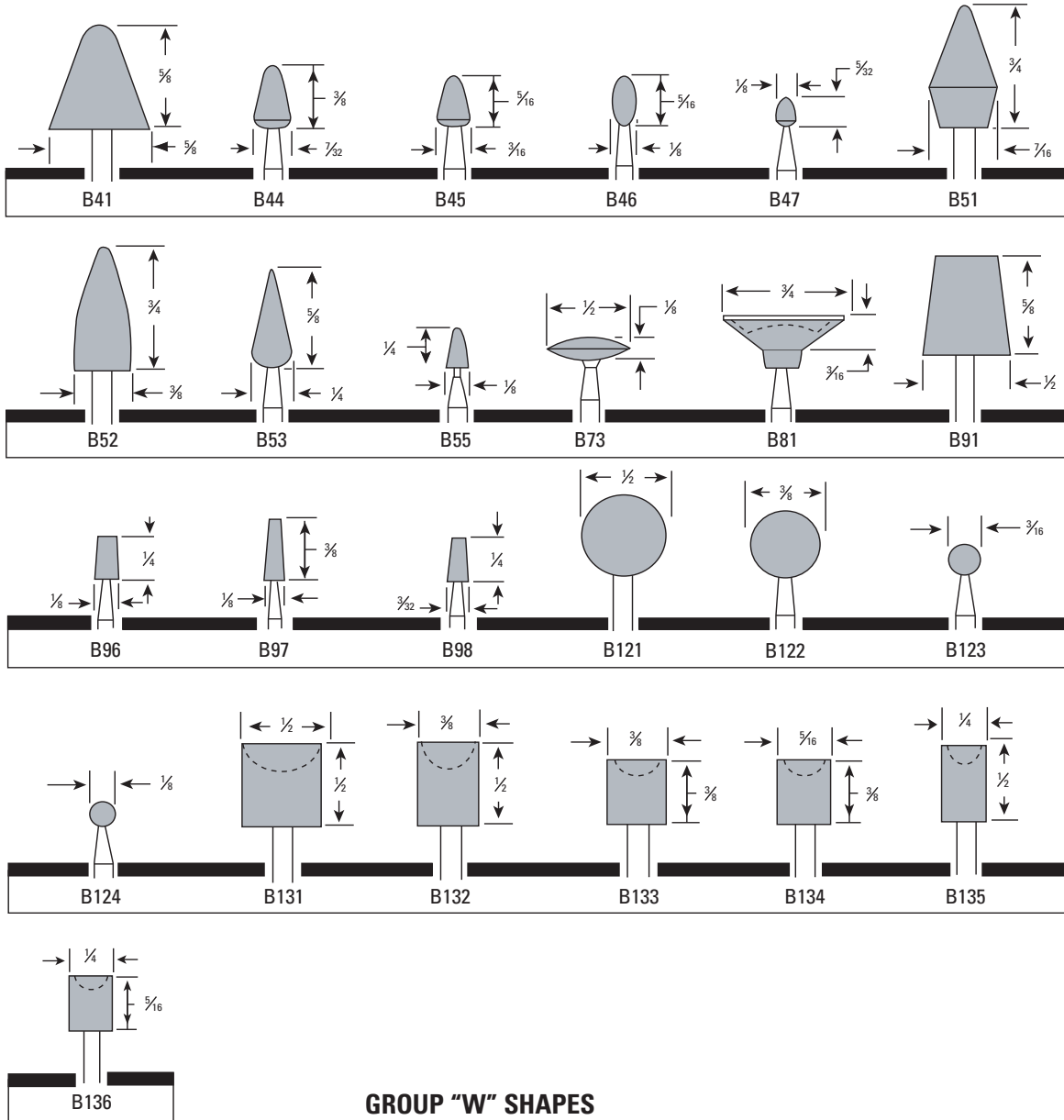

GROUP "W" SHAPES

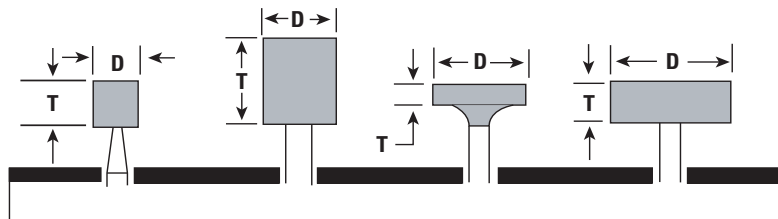













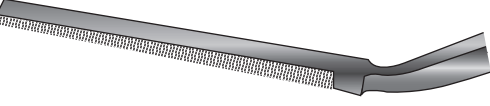
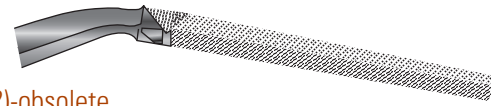



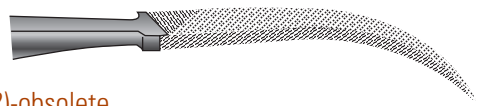







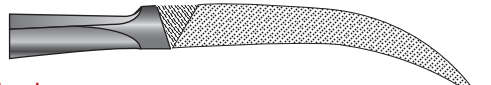



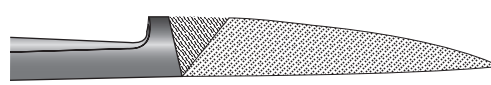





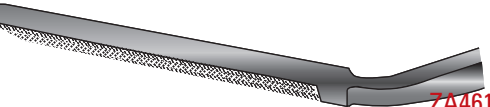

Rifflers

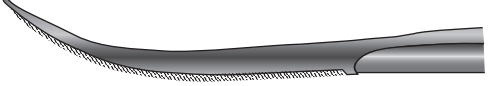
Rifflers

These Swiss Quality Heavy-Duty Moldmakers' Rifflers are made of chrome alloy steel for longer cutting life. They are ideal for "roughing-out" cavities in molds or die cast dies. Because of their length (12 inches), they provide ample surface to grasp and "bear-down" on the work.

ITEM NUMBER PREFIX*

		ZA410		
		ZA411 ZA411(2)-obsolete		
		ZA412 ZA412(2)-obsolete		
		ZA430 ZA430(2)-obsolete		
		ZA440 ZA440(0) & ZA440(2)-obsolete		
		ZA450 ZA450(2)-obsolete		
		ZA460 ZA460(2)-obsolete		
		ZA461 ZA461(0) & ZA461(2)-obsolete		
		ZA470 ZA480(2)-obsolete		
		ZA480 ZA480(2)-obsolete		

AVAILABLE IN "0" AND "2" CUT ALL RIFFLERS ARE 7" LONG
 "0" cut – 64 teeth/inch
 "2" cut – 97 teeth/inch

WHEN ORDERING, PLEASE SPECIFY:
 1. Item Number
 2. Quantity
 3. Method of shipment

*When ordering, add "0" or "2" to end of item number to indicate cut desired (e.g. ZA4110)

Silversmiths' Rifflers | Quick-Change Riffler Handles

Silversmiths' Rifflers

These Swiss Quality Precision Silversmiths' Rifflers are made of chrome alloy steel for longer cutting life. They are unsurpassed as to precision of shape, accuracy of size, hardness and durability.

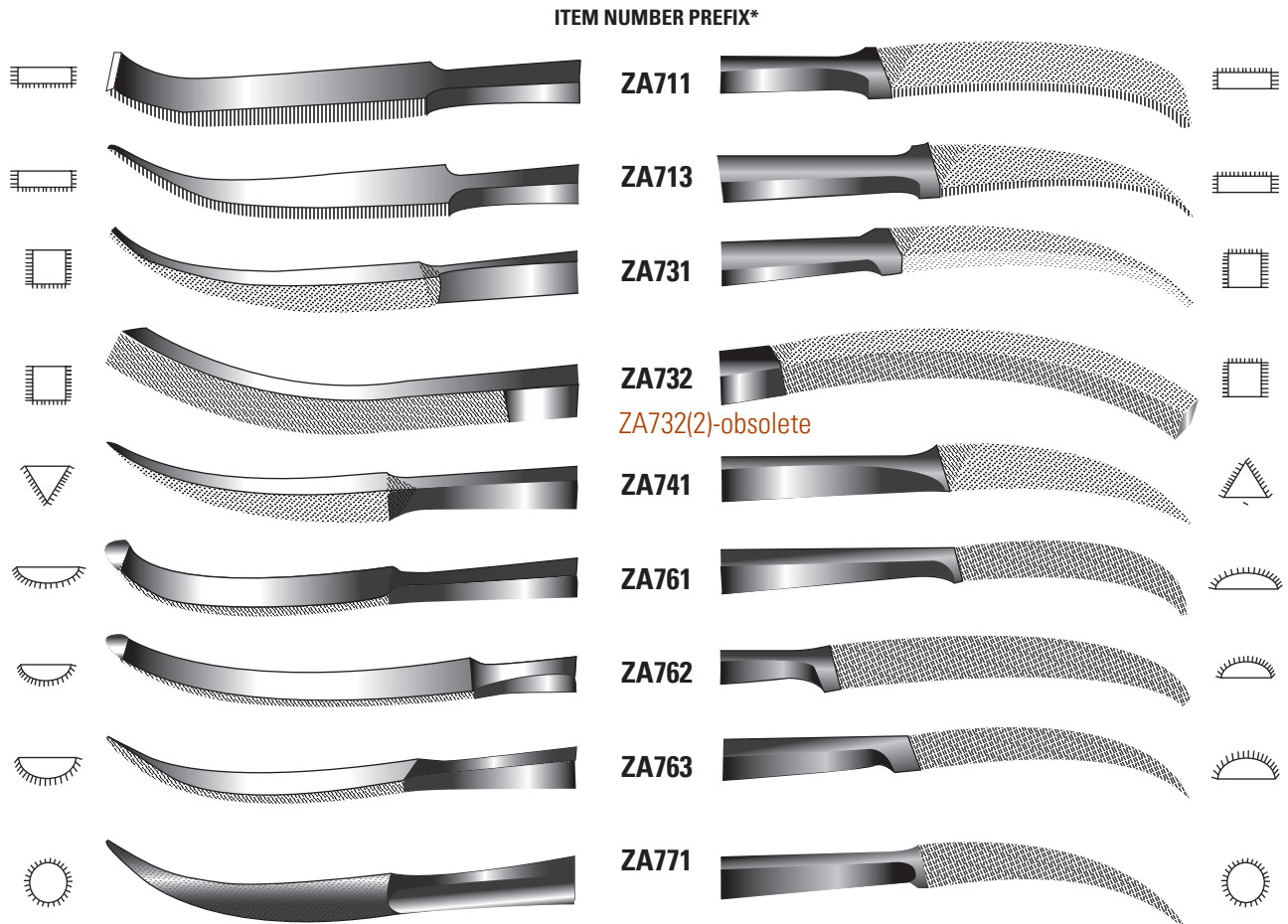

AVAILABLE IN "0" AND "2" CUT ALL RIFFLERS ARE 7" LONG

"0" cut – 64 teeth/inch

"2" cut – 97 teeth/inch

WHEN ORDERING, PLEASE SPECIFY:

1. Item Number
2. Quantity
3. Method of shipment

*When ordering, add "0" or "2" to end of item number to indicate cut desired (e.g. ZA7110)

Die Sinkers' Rifflers

Die Sinker Rifflers

Exceptional Quality Swiss Die Sinkers' Rifflers are made of chrome alloy steel in the tradition of superior craftsmanship for longer cutting life. They are unsurpassed as to precision of shape, accuracy of size, hardness and durability.

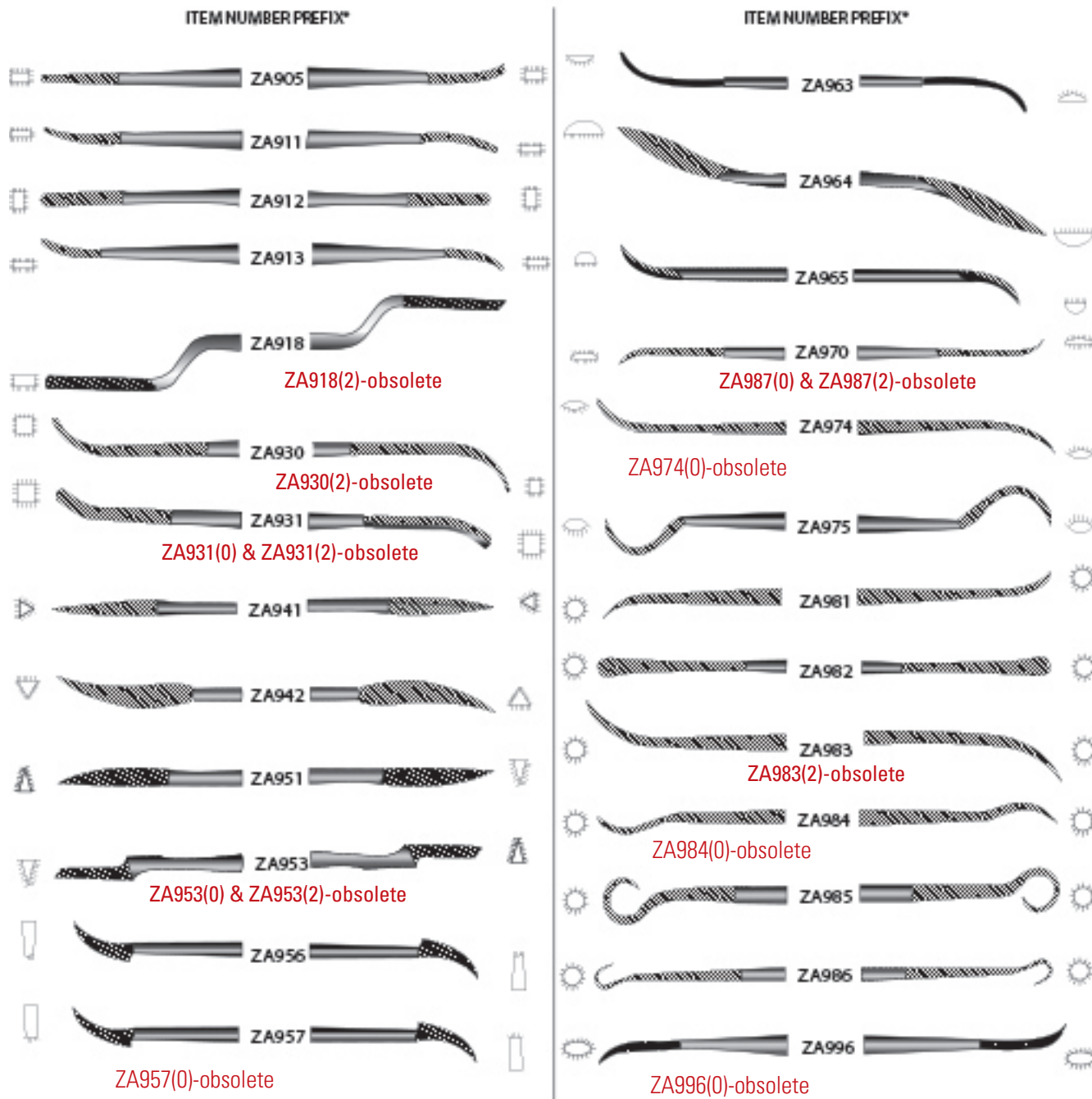

AVAILABLE IN "0" AND "2" CUT ALL RIFFLERS ARE 6" LONG
 "0" cut – 64 teeth/inch
 "2" cut – 97 teeth/inch

*When ordering, add "0" or "2" to end of item number prefix to indicate cut desired (e.g. ZA9050)

WHEN ORDERING, PLEASE SPECIFY:

1. Item Number
2. Quantity
3. Method of shipment

Habilis Files | Diamond Needle Files

Habilis Files

CHROME ALLOY STEEL, INTEGRAL HANDLE

DME Habilis Files are made from chrome alloy steel. They are just right for those in-between jobs when a full-size file is too large. The file and integral handle are balanced to give the mold or die maker full control for efficient cutting.

A complete set, stored in a sturdy vinyl pouch, includes one each of these five popular file shapes: rectangular, half-round, triangular, square and round. These handy Habilis Files are available in coarse (00) and medium (1) cut. Files of the same shape and same cut may be purchased in boxes of ten.

Set of 5 Files	
CUT	ITEM NUMBER
00	HFS00
1	HFS1

FILE SHAPE	00 CUT	1 CUT	FILE CONTOUR DIMENSIONS	CUT LENGTH
	ITEM NUMBER	ITEM NUMBER		
Rectangular	HFP00	HFP1	$\frac{3}{8} \times \frac{1}{8}$	4"
Half-Round	HFF00			
Triangular	HFT00	HFT1	$\frac{3}{8}$	4"
Square	HFL00			
Round	HFR00	HFR1	$\frac{1}{4}$	4"



Set of five files in a vinyl pouch.
Overall length of files is 8½".

Diamond Needle Files

FOR FILING HARDENED STEELS, CARBIDES AND CERAMICS

DME Diamond Needle Files are specially made for moldmakers. They feature efficient cutting action with only the slightest pressure and provide long tool life. The Diamond Needle Files are 5½" long with approximately 2¾" diamond surface. The round shanks are knurled to prevent slippage.

A complete set, stored in a sturdy vinyl pouch, includes one each of these five popular file shapes: rectangular, half-round, triangular, square and round. Diamond Needle Files may also be purchased individually.

FILE SHAPE	ITEM NUMBER
Rectangular	DNFP
Triangular	DNFT
Round	DNFR

Set of 5 Files
ITEM NUMBER
DNFS5



Set of five files in a vinyl pouch.
Overall length of files is 5½".

GRIT = 75 microns
(180 MESH)

Abrasive Stones

For General and Special Purpose Stoning, Finishing and Polishing of Molds and Dies

GENERAL PURPOSE STONES

These silicon carbide, vitrified bond stones are available in two types:

TYPE A: For use on steel prior to heat treating or for steel hardness lower than 40 HRC.

TYPE B: For steel hardness higher than 40 HRC. Ideal for restoring finish after heat treating.

SPECIAL PURPOSE STONES

Available in three types:

TYPE E (EDM STONES): Aluminum oxide crystals in a medium hard vitrified bond, with a special resin treatment to improve cutting action on hard surface crusts, such as those produced by EDM.

TYPE M (MEDIUM OIL FILLED): Aluminum oxide crystals in a hard vitrified bond, with a special oil fill which eliminates the soaking often recommended for abrasive stones. The oil fill provides additional lubrication to prevent loading and assure optimum stock removal. Ideal for heat treated tool steels.

TYPE F (DME FLEX): Aluminum oxide crystals in a hard resin bond provide some flexibility to reduce breakage. Ideal for polishing deep ribs and fine details.

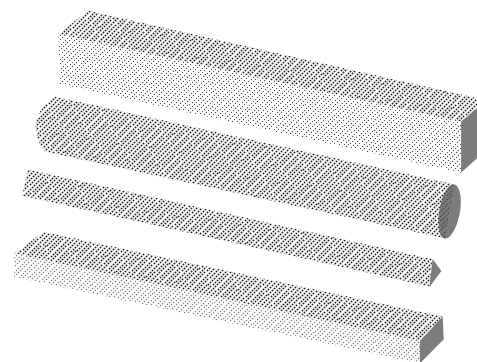

GENERAL PURPOSE (TYPE A OR B)

RECTANGULAR			GRIT		
THK.	WIDTH	LGTH.	150 & 240	400	600
1/16	1/2	4"	•	•	•
1/8	1/2	4"	•	•	•
3/16	1/2	4"	•	•	•
1/4	3/4	4"	•	•	•
1/2	3/4	4"	•	•	•
1/2	1"	4"	•	•	•

GENERAL PURPOSE (TYPE A OR B)

SQUARE		GRIT		
SIZE & SHAPE	LGTH.	150 & 240	400	600
1/4 SQ	4"	•	•	•
3/8 SQ	4"	•	•	•
1/2 SQ	6"	•	•	•
3/4 SQ	6"	•	•	•

GENERAL PURPOSE (TYPE A OR B)

TRIANGULAR		GRIT		
SIZE & SHAPE	LGTH.	150 & 240	400	600
1/4 TRI	4"	•	•	•
1/2 TRI	4"	•	•	•

GENERAL PURPOSE (TYPE A OR B)

ROUND		GRIT		
SIZE & SHAPE	LGTH.	150 & 240	400	600
1/4 RD	4"	•	•	•
3/8 RD	4"	•	•	•
1/2 RD	4"	•	•	•

WHEN ORDERING, PLEASE SPECIFY:

- Quantity
- Size, Shape, Grit and Type
Rectangular Example: 116124150A
Square Example: 14SQ4400A

SPECIAL PURPOSE (TYPES E, M OR F)

For other stones (sized for use with profilers), see Page 41.

SHAPE AND SIZE			TYPE E (EDM STONES) GRIT					TYPE M (MEDIUM OIL FILLED) GRIT					TYPE F (DME FLEX) GRIT				
RECTANGULAR																	
THICK.	WIDTH	LENGTH	150	240	320	400	600	150	240	320	400	600	150	240	320	400	600
1/16	1/4	4"	•	•	•	•	•	•	•	•	•	•	•	•	•	•	•
1/8	1/4	4"	•	•	•	•	•	•	•	•	•	•	•	•	•	•	•
1/8	1/2	4"	•	•	•	•	•	•	•	•	•	•	•	•	•	•	•
1/4	1/2	4"	•	•	•	•	•	•	•	•	•	•	•	•	•	•	•
SQUARE			GRIT					GRIT					GRIT				
SIZE AND SHAPE	LENGTH		150	240	320	400	600	150	240	320	400	600	150	240	320	400	600
1/8 SQ	4"		•	•	•	•	•	•	•	•	•	•	•	•	•	•	•
1/4 SQ	4"		•	•	•	•	•	•	•	•	•	•	•	•	•	•	•

Abrasive Stone Kit

Abrasive Stone Kit

This useful kit designed for the professional metal finisher contains a complete selection of 45 aluminum oxide special-purpose stones, plus one handheld stone holder. The special-purpose stones consist of:

- “Type E” (resin treated) for work on hard surface crusts such as EDM
- “Type M” (oil filled) for stoning heat-treated tool steels
- “Type F” (resin bonded) for added flexibility and break resistance when stoning deep ribs and fine details



ABRASIVE STONE KIT ITEM NUMBER: ASK450

ABRASIVE STONE KIT ITEM NUMBER ASK450 INCLUDES:

SHAPE AND SIZE			TYPE E [EDM STONES]	TYPE M (MEDIUM OIL FILLED)	TYPE F (DME FLEX)
RECTANGULAR			1 EACH OF GRIT	1 EACH OF GRIT	1 EACH OF GRIT
THICK	WIDTH	LENGTH			
1/8"	1/4"	4"	150, 240, 320, 400, 600	150, 240, 320, 400, 600	150, 240, 320, 400, 600
1/8"	1/2"	4"	150, 240, 320, 400, 600	150, 240, 320, 400, 600	150, 240, 320, 400, 600
SQUARE			1 EACH OF GRIT	1 EACH OF GRIT	1 EACH OF GRIT
1/4" x 1/4"		4"	150, 240, 320, 400, 600	150, 240, 320, 400, 600	150, 240, 320, 400, 600

Abrasive Sheets | Cloth Bench Rolls | Discs and Holders

Abrasive Sheets

ALUMINUM OXIDE CLOTH AND SILICON CARBIDE WATERPROOF PAPER

- 9" x 11" Sheets
- 50 Sheets per Carton

ALUMINUM OXIDE ABRASIVE CLOTH SHEETS

ITEM NUMBER (CARTON OF 50 SHEETS)	GRIT
ABC80	80
ABC100	100
ABC120	120
ABC180	180
ABC240	240
ABC320	320
ABC400	400
ABC500	500

SILICON CARBIDE WATERPROOF PAPER

ITEM NUMBER (CARTON OF 50 SHEETS)	GRIT
ABW220	220
ABW280	280
ABW320	320
ABW400	400
ABW500	500
ABW600	600



Abrasive Cloth Bench Rolls

ALUMINUM OXIDE



50 YARD ROLLS			
1" WIDE		2" WIDE	
ITEM NUMBER	GRIT	ITEM NUMBER	GRIT
ABR601	60	ABR602	60
ABR801	80	ABR802	80
ABR1001	100	ABR1002	100
ABR1201	120	ABR1202	120
ABR1801	180	ABR1802	180
ABR2401	240	ABR2402	240
ABR3201	320	ABR3202	320
ABR4001	400	ABR4002	400

Abrasive Discs and Holders

ABRASIVE DISCS (SELF ADHESIVE)

DIA.	GRIT	ITEM NUMBER (PACK OF 50)
½	60	EPD260
	80	EPD280
	120	EPD2120
	240	EPD2240
¾	320	EPD2320
	60	EPD360
	80	EPD380
	120	EPD3120
1	240	EPD3240
	320	EPD3320
	60	EPD460
	120	EPD4120
1	240	EPD4240
	320	EPD4320

ABRASIVE DISC HOLDERS (1/8" SHANKS)

DIA.	ITEM NUMBER (PACK OF 5)
½	EPDH2
¾	EPDH3
1	EPDH4

DISC HOLDER SET

ONE EACH OF EPDH2, H3, H4
ITEM NUMBER
EPDH234



Felt Polishing Kit | Polishing Brushes | Mold Polishing and Lapping Compound

Felt Polishing Kit

NYLON HOLDERS AND FELT WHEELS

POLISHING KIT CONTENTS:

- (1) Storage Box shown at right
- (12) ¼ Felt Wheels
- (8) ½ Felt Wheels
- (6) ¾ Felt Wheels
- (1 ea.) ¼, ½, ¾ Holder



NO CENTER SCREW TO MAR THE WORK FINISH. Nylon Holders have side and bottom grips to prevent slipping.

NYLON HOLDERS*				FELT WHEELS**		
ITEM NUMBER	NOM. DIA.	SHAFT DIA.	A	ITEM NUMBER	NOM. DIA.	L
14NH	¼	⅛	¼	14FW	¼	½
34NH	¾	⅛	⅝	34FW	¾	⅝
1NH18	1	⅛	⅝	1FW	1	1 1/16
1NH14	1	¼	⅝	1FW	1	1 1/16
112NH	1 ½	¼	⅝	112FW	1 ½	1 1/16

*Sold in packs of 5 only **Sold in packs of 10 only

POLISHING KIT
ITEM NUMBER
FPK326

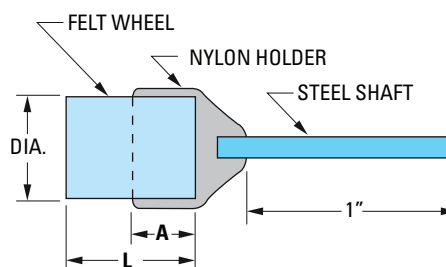

Polishing Brushes

AVAILABLE IN BRISTLE OR BRASS

ALL BRUSHES HAVE ⅛ DIAMETER SHANKS			
BRISTLE	BRUSH DIAMETER	STYLE	BRASS
ITEM NUMBER*			ITEM NUMBER*
PB7	⅜	END BRUSH	PBR7
PB12	½	SMALL CUP	—
PB11	⅝	LARGE CUP	PBR11
PB1	¾	WHEEL	PBR1

*PACK OF 10



Mold Polishing and Lapping Compound

FLASH POINT = 335°F
FLAMMABLE LIMIT = 345°F

DME Mold Polishing and Lapping Compound is made of an aluminum oxide abrasive powder mixed with a mineral-based carrier agent. It is an inexpensive and effective compound for polishing with brushes and brass or wood laps. Ideal for mold polishing, it can also be used for such applications as lapping bushing I.D.'s or enlarging undersized ejector pin bores.

ITEM NUMBER*	GRIT
PLC220	220
PLC280	280
PLC400	400
PLC600	600

*16 oz. can



Diamond Compound | Thinner Lubricator

Diamond Compound

FOR HIGH-QUALITY MOLD AND DIE POLISHING

Quality of mold or die finish is frequently an important factor in how a mold or die operates. DME Diamond Compound is proven to produce the finest quality finish with considerable savings in time and labor.

DME Diamond Compound contains no adulterants, nor non-graded, non-working diamond “fines”. The precision-graded diamond particles are uniformly and permanently dispersed and blended in a high-quality, universally soluble, synthetic vehicle; giving the best composition possible. It will not “cake” or dry out and is completely stable at temperatures from –50°F to +150° F, permitting high-speed mechanical polishing operations.

Available in 2½ gram, 5 gram, and 18 gram sizes.

Since DME Diamond Compound is not water soluble, the use of water as a thinning agent is not recommended. For best results, use DME THINNER LUBRICATOR to reduce the compound to its most efficient working consistency.

FINISH	ITEM NUMBER	LABEL COLOR GUIDE	NAT'L BUR. STD. GRADE	MICRON SIZE. RANGE*	COMPOUND NUMBER AND DIAMOND CONTENT	APPROX. MESH EQUIVALENT
Final ultra-mirror polishing of plastics mold cavities.	DC00H	Pink	¼	0-½	½-Heavy	100,000
	DC0H	Silver	½	0-1	1-Heavy	60,000
Final high-mirror polishing of selected work such as optical quality plastics mold cavities.	DC1M	Ivory	1	0-2	1-Medium	15,000
	DC1H	Ivory	1	0-2	1-Heavy	15,000
Final mirror-polishing of high-quality plastics mold cavities, especially those producing clear plastic parts.	DC3M	Yellow	3	1-5	3-Medium	9,000 to 7,000
	DC3H	Yellow	3	1-5	3-Heavy	9,000 to 7,000
Final polishing of most plastics mold cavities.	DC6U	Orange	6	4-8	6-Universal	5,000 to 2,500
	DC6M	Orange	6	4-8	6-Medium	5,000 to 2,500
Intermediate polishing of plastics mold cavities and final polishing of die cast die cavities.	DC9U	Green	9	6-12	9-Universal	1,300
	DC9M	Green	9	6-12	9-Medium	1,300
	DC15U	Blue	15	8-22	15-Universal	1,300 to 900
	DC15M	Blue	15	8-22	15-Medium	1,300 to 900
Preliminary polishing of all plastics mold and die cast die cavities.	DC30U	Red	30	20-40	30-Universal	800 to 550
	DC30M	Red	30	20-40	30-Medium	800 to 550
	DC45U	Brown	45	30-60	45-Universal	500
	DC45M	Brown	45	30-60	45-Medium	500
Heavy stock removal. Enlarging holes in hardened steel.	DC170H	Grey-Black	170		170M-Heavy	120 to 80

*The smaller the micron size, the finer the finish.

Mold Finish Comparison Kit

Mold Finish Comparison Kit

EXPANDED VERSION – 12 SAMPLES FINISHED TO SPI STANDARDS

- Eliminates errors or guesswork in achieving desired or specified finishes
- Saves time...eliminates over-polishing
- Provides a visual and numerical standard for specifying mold/part finishes

Professionally finished to SPI standards, this kit is an invaluable tool for both selection of finishes required and comparison to work in progress. The visual and numerical standards are also helpful in communications between end user, molder and moldmaker. Each finish has been generated on a 1" diameter x $\frac{3}{8}$ "-thick piece of 420 Stainless Steel. Edges are chamfered and O.D. is knurled for safe, easy pick-up and handling. Finish numbers are stamped on the back of each sample for quick reference. A molded plaque in the kit's lid shows the part finishes that result from each mold finish.



ITEM NUMBER

MFK1200

FINISH TYPE	DESCRIPTION	ROUGHNESS AVERAGING (RA) micro-inches range	COMMENTS
A1	grade # 3 diamond buff	0-1	<ul style="list-style-type: none"> • for mirror or optical finishes • most time consuming and costly finishes to achieve • steel grade important to results (DME No. 3 or No. 5 steel recommended)
A2	grade # 6 diamond buff	1-2	
A3	grade # 15 diamond buff	2-3	
B1	600 grit paper	2-3	<ul style="list-style-type: none"> • removes all tool and machining marks
B2	400 grit paper	4-5	<ul style="list-style-type: none"> • provides good mold release
B3	320 grit paper	9-10	<ul style="list-style-type: none"> • light reflecting finish on molded part, some sheen
C1	600 stone	10-12	<ul style="list-style-type: none"> • removes all tool and machining marks
C2	400 stone	25-28	<ul style="list-style-type: none"> • provides good mold release
C3	320 stone	38-42	<ul style="list-style-type: none"> • mute finish on molded part, no sheen
D1	dry blast glass bead #11 (8" distance at 100 psi; 5 secs.)	10-12	<ul style="list-style-type: none"> • for decorative finishes
D2	dry blast # 240 oxide (5" distance at 100 psi; 6 secs.)	26-32	<ul style="list-style-type: none"> • often used for diecast and thermoset tooling • helps hide shrink marks and other imperfections
D3	dry blast # 24 oxide (6" distance at 100 psi; 5 secs.)	190-230	<ul style="list-style-type: none"> • dull, non-reflecting finish on molded or cast part

Finishing Applications

The DME Ultraform Ultrasonic Finishing and Polishing System is highly effective at rapid deburring, filing, stoning, polishing and lapping on a variety of surfaces, including EDM, tungsten carbide, and mold steel. Available in two types of ultrasonic models, the units replace costly, time-consuming hand finishing operations.

DME carries a large selection of finishing and polishing hand tools, as well as mechanical devices, that are required to complete the final contours and finishes of molds.

In addition to the Ultraform, DME carries a large selection of finishing and polishing hand tools, as well as mechanical devices, that are required to complete the final contours and finishes of molds. While mold finishers and polishers hone different techniques that are unique to each individual, most require access to a broad variety of tools and materials in order to accomplish a specific task.

Handpieces like those in the Minitor D Series perform well for light metal removal in the mold finishing process. A wide selection of carbide burrs, mounted stones and similar accessories in different shapes, sizes and grits provide the ability to achieve a preferred finish.

DME's extensive selection of files, especially riffles, offers a wide array of shapes, cuts and tooth structures. These tools are excellent at getting into areas that would be impossible to access with conventional files.

An assortment of abrasive products, including stone kits and abrasive sheets, cloths and discs, are available in various grit sizes. Polishing sticks for hand or Profiler applications are also stocked.

For that high polished "super" finish or "mirror" finish on a mold surface, DME Diamond Compound is available in three applicator syringe sizes.



Important Mold Finishing Tips

- When hand grinding in the same direction of the cutting tool rotation, use extra caution since this motion can cause the stone to cut deeper than the desired depth. Also, don't try to cover too large of an area at any one time. Working on a number of small areas and blending them together provides more uniform results.
- Use extra care to remove all foreign substances when filing over an area on which some form of abrasive has previously been used. The grit from abrasive stones or cloths will usually be charged into the surface of the metal, causing the file to dull rapidly.
- When filing an area that must be flat, crisscross file strokes. This removes waves and ripples that develop when working in only one direction.
- Stones of the same grit, but made from different abrasive materials and with a different type of bond, may produce different finishes.
- Do not mix grades of diamond compound. And, if the first grade of diamond compound used does not remove marks from the most recent stoning operation, don't continue. These marks must be removed with a coarser grade of compound or the surface will have highly polished, shiny scratches.

DME ProWeld™

RoHS/WEEE COMPLIANT
MICRO-WELDING SYSTEM
FOR PRECISION MOLD REPAIR

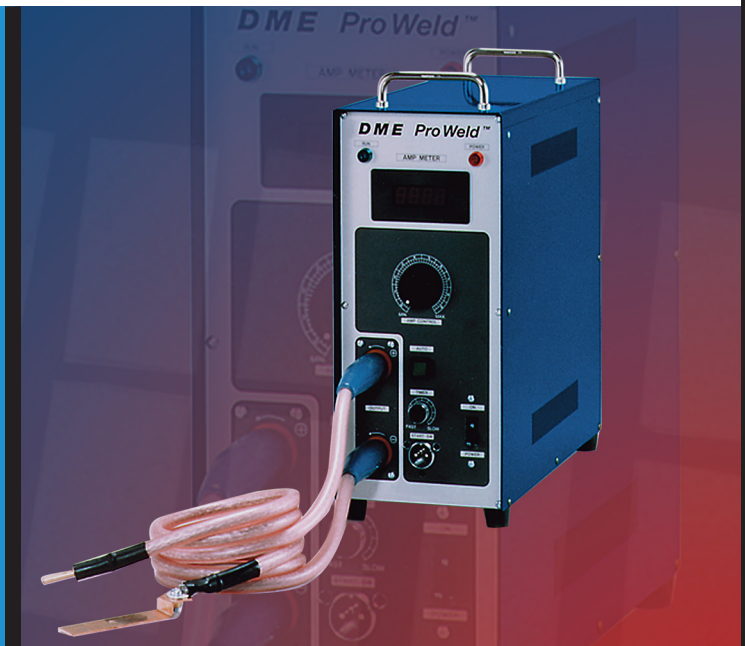

ProWeld™ Benefits

Advantages of ProWeld

- Perform high-quality repairs of very small mold areas
- Increase the life of a mold after repair
- Reduce repair costs up to 85% with special metal alloys developed for all conventional types of steel
- Modern control electronics ensure a homogenous welding pattern even under the most difficult working conditions
- Process emits almost no heat
- Weld material is not excessive – hand and machine finishing is easy
- Only gentle pressure is required on welding electrodes to prevent the formation of cavities or pin holes
- Magnetic electrodes pick up metal powder which can be easily placed on the workplate
- Suitable for all forms of mold damage; no need for other types of welding, e.g. argon, laser welding, TIG
- Safe and easy to operate, no special training needed
- Emits no harmful welding fumes or toxic gases
- No scaling or flaking. High-quality welding alloys are free of impurities. The resulting weld is strong, homogenous and reliable

Precision Mold Repairs and Alterations Made Easy with ProWeld

Figure 1

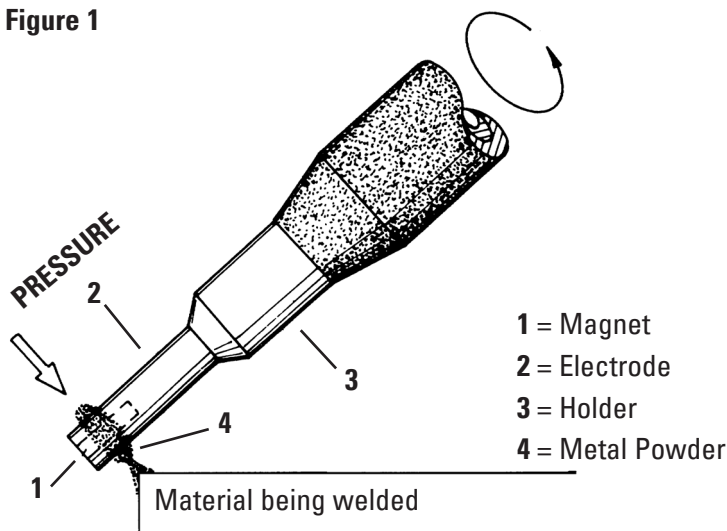

The Micro-Welding Method

With only gentle pressure ProWeld uses electrical pulses to fuse metal powder, metal sheets, strips or wire etc., to the contour of the mold under repair (Fig. 1).

Figure 2



Figure 3

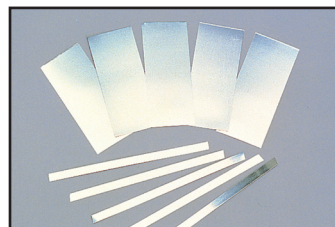

Using the appropriate electrode, powder (Fig. 2), metal or strips (Fig. 3), which contain alloying properties of the material being welded, are first fused then bonded to the base metal by a systematic and controlled supply of energy.

Figure 4

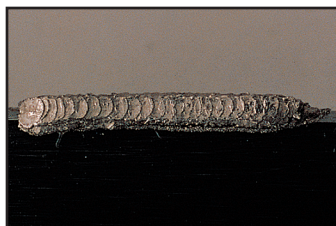
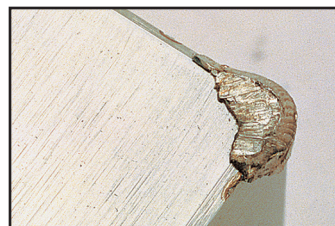

Figure 5



This produces a weld (Figs. 4 and 5) which also can be controlled by various adjustments of the power pack (frequency of the electrical pulses, output current). Special training is not needed to successfully perform this welding process.

ProWeld™ Standard Equipment

Proweld

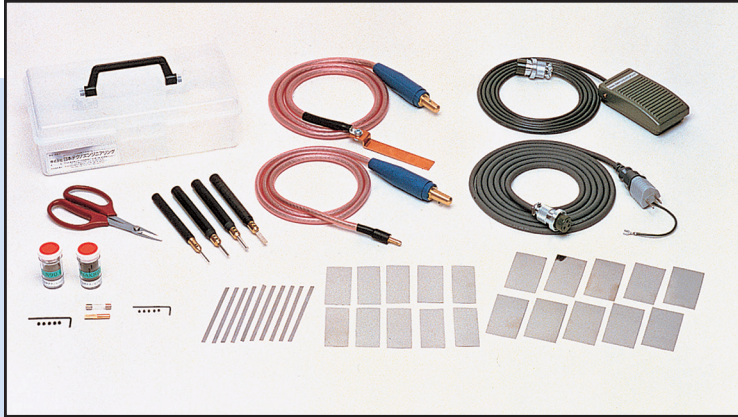

Standard Equipment

Complete ProWeld system includes:
(Dimensions in millimeters)

ITEM NUMBER	DESCRIPTION
UMW0001	Power pack with welding cord, grounding cord and plate, power cord, foot switch and all accessories listed below
UMW0002	N51—Standard SKH-51 steel powder (40 grams) (63 Rc; for D-2/M-2/S-7 steels)
UMW0003	N80—Standard NAK80 steel powder (40 grams) (38-40 Rc; for P-20/P-21 steels)
UMW0004	NAK80—Standard steel sheet (10 sheets, 0.1T x 5W x 100L) (38-40 Rc; for P-20/P-21 steels)
UMW0005	NTA1—Ni Alloy sheet (10 sheets, 0.1T x 30W x 70L) (135HV; for all steels)
UMW0006	NTA2—Ni Alloy sheet (10 sheets, 0.2T x 30W x 70L) (135HV; for all steels)
UMW0009	Magnet electrode (2 dia. x 50L)
UMW0010	Magnet electrode (3 dia. x 50L)
UMW0011	Magnet electrode (4 dia. x 60L)
UMW0012	Magnet electrode (4 dia. x 50L)
UMW0013	Standard electrode (2 dia. x 50L)
UMW0014	Standard electrode (3 dia. x 50L)
UMW0015	Standard electrode (4 dia. x 50L)
UMW0016	Standard electrode (1.2T x 5W x 35L)
UMW0017	Standard electrode holder (black) (used with UMW0015)
UMW0018	Magnet electrode holder (brown) (used with UMW0011 and UMW0012)
UMW0019	Standard electrode holder (black) (used with UMW0016)
UMW0020	Standard electrode holder (black) (used with UMW0013)
UMW0021	Standard electrode holder (black) (used with UMW0014)
UMW0022	Magnet electrode holder (brown) (used with UMW0009 and UMW0010)

NOTE: See next page for additional welding materials.

SPECIFICATIONS

Input Voltage	120 VAC
Consumable Power	600 VA
Output Power	700W
Output Voltage	0 – 9V
Output Current	0 – 1100 Amps
Control System	SCR Switching System
Auto Timer On	0.5 sec.
Dimensions (inches)	W6.5 x D17.75 x H16
Weight	62 lbs

**ProWeld Micro-Welding System
Now RoHS/WEEE Compliant**

As an essential resource to thousands of customers around the globe, DME is diligent in making certain its products are compatible in every region of the world. That's why every component within the Pro-Weld system satisfies all international compliances. This included RoHS (Restriction of Hazardous Substances) that prohibits or restricts the use of six potentially harmful materials in electronic equipment, and WEEE (Waste Electrical and Electronic Equipment) that requires equipment made after August 2005 to be returned to the manufacturer and recycled, rather than just "thrown away."

Additional Welding Materials for ProWeld™

Proweld Accessories

Welding Material: Powder

ITEM NO.	WELDING MATERIALS	JAPANESE MOLD STEEL	QUANTITY	HARDNESS ROCKWELL C	U.S. MOLD STEEL EQUIVALENT
UMP0067	N-11	SKD-11	40 grams	Rc 50-60 Min.	A-2, D-2
UMP0072	N-38	HPM38	40 grams	Rc 30 Max.	All Die Steels 420SS (Prehardened)
UMP0073	N-39	PD555	40 grams	Rc 50-52	STAVAX
UMP0060	N-40	Ni-Cr Alloy	40 grams	Rc 36-42	All Mold Steels
UMP0062	N-50	Ni Alloy	40 grams	Rc 47-53	All Mold Steels
UMP0068	N-61	SKD61	40 grams	Rc 40-53 Max.	H-13, 420SS
UMP0063	N-13	Ni Alloy	40 grams	Rc 10-15	All Mold Steels
UMP0061	N-90	Ni Alloy	40 grams	Rc 16-20	All Mold Steels
UMP0071	N-55	NAK55	40 grams	Rc 38-41	P-21

Welding Material: Sheet (dimensions in millimeters)

ITEM NO.	WELDING MATERIALS	JAPANESE MOLD STEEL	QUANTITY	HARDNESS ROCKWELL C	U.S. MOLD STEEL EQUIVALENT
UMA0001	NT-6		10 / 0.2T x 5w x 100L	Rc 30	All Mold Steels
UMA0054	NS-1	SS Alloy	10 / 0.1T x 30w x 70L	Rb 90	All Mold Steels
UMA0055	NS-2	SS Alloy	10 / 0.2T x 30w x 70L	Rb 90	All Mold Steels
UMD0102	HPM-50	HPM50	10 / 0.2T x 5w x 100L	Rc 38-40	P-21 Improved
UMD0107	HPM-38	HPM38	10 / 0.2T x 5w x 100L	Rc 30-33	420SS
UMD0104	STAVAX	STAVAX	10 / 0.2T x 5w x 100L	Rc 50-52	STAVAX, 420SS
UMD0101	HPM-2	SCM440, IMPAX, HPM-2	10 / 0.2T x 5w x 100L	Rc 30-50	P-20
UMD0103	MAS1		10 / 0.2T x 5w x 100L	Rc 50-53	P-20
UMD0106	NAK55	NAK55	10 / 0.2T x 5w x 100L	Rc 38-40	P-21

Welding Material: Wire

ITEM NO.	WELDING MATERIALS	JAPANESE MOLD STEEL	QUANTITY	HARDNESS ROCKWELL C	U.S. MOLD STEEL EQUIVALENT
UMA0056	S2	SS Alloy	1 / 0.2 dia. x 5m	Rb 90	All Mold Steels
UMA0057	S3	SS Alloy	1 / 0.3 dia. x 5m	Rb 90	All Mold Steels
UMA0058	S4	SS Alloy	1 / 0.4 dia. x 5m	Rb 90	All Mold Steels
UMA0059	S5	SS Alloy	1 / 0.5 dia. x 5m	Rb 90	All Mold Steels

THOUSANDS OF AUXILIARY ITEMS
THAT HELP KEEP YOUR
PROCESSING INITIATIVES AT
PEAK PERFORMANCE

DME Molding Supplies



Mold Cleaner and Mold Saver

Available in 12 oz. aerosol or 1 gallon non-aerosol...
individually or by the case.

DME MOLD CLEANER

DME Mold Cleaner is used to remove corrosion-forming substances such as lactic acid, urea and sodium chloride, which are common in perspiration residues left by ordinary handling of polished cavities. In addition to cleaning the polished cavity it also provides up to 20 days rust protection at temperatures to 120°F at 100% humidity.

Use DME Mold Cleaner to clean polished mold surfaces and protect them for up to 20 days. Use DME Mold Saver for long-lasting protection from corrosion.

ITEM NUMBER	MOLD CLEANER DESCRIPTION
CLE0001	(1) 12 oz. aerosol can
CLE0012	Case of (12) 12 oz. aerosol cans
CLE0004	(1) one gallon can
CLE0016	Case of (4) one gallon cans



DME MOLD SAVER

DME Mold Saver is an ideal protective coating for molds to be stored over a long period of time. It protects polished cavities and all metal parts from costly corrosion damage. Its thin, transparent film averages about .0003" thick. It is soft, dry and waxy and can be easily wiped off without solvents. One can of Mold Saver covers about 80 square feet.

ITEM NUMBER	MOLD SAVER DESCRIPTION
SAV0001	(1) 12 oz. aerosol can
SAV0012	Case of (12) 12 oz. aerosol cans
SAV0004	(1) one gallon can
SAV0016	Case of (4) one gallon cans



ACCESSORIES FOR MOLD CLEANER AND MOLD SAVER

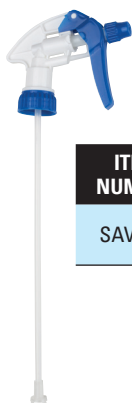

TRIGGER PUMPS
for 15 oz. cans

ITEM NUMBER	DESCRIPTION
SAV0003	Package of (6) trigger pumps

"SURE SHOT" COMPRESSED-AIR SPRAY CANISTER

Holds one quart of Mold Cleaner or Mold Saver. Metal can is refillable and reusable. Includes stemmed air valve and safety valve.



ITEM NUMBER	DESCRIPTION
SS1000*	1 qt. (32 oz.) capacity painted steel; choose: red, green, black or white. 2.5 lbs empty weight, includes 30 oz multi-purpose nozzle

*Please specify color after item number. Example: SS1000red

Mold Release Sprays

Mold Release Sprays

- Improves productivity and reduces rejects
- Virtually no build-up, extends the life of your mold
- Large, 16 oz. fill
- Three formulations to suit a wide range of release applications

DME's line-up of Mold Release Sprays provide production-proven value at an economical price. These long-lasting, top-quality sprays are ideal for most applications and plastics materials. They will actually improve mold cycle times while reducing scrap. Try these specially formulated Mold Release Sprays and give yourself a competitive edge.



PREMIUM SILICONE MOLD RELEASE

This premium-quality silicone mold release has been formulated to provide superior performance for most plastics molding applications. The high silicone content and standard concentration of propellants are FDA approved for food industry applications under section 175.300 of the Food and Drugs Code of Federal Regulations. This long-lasting, low build-up mold release is the ideal product for tough, sticking problems that require a top-quality lubricant.

ITEM NUMBER*

MRFS514

SILICONE MOLD RELEASE

This all-purpose silicone mold release has been formulated to provide dependable performance with outstanding economy. The long-lasting, low build-up silicone concentration is ideal for most plastics molding applications.

ITEM NUMBER*

MRES414

PAINTABLE MOLD RELEASE

Contains no silicone

This high-quality mold release is a special formulation that will not interfere with cosmetic operations such as painting, plating, hot stamping, etc. The low concentration does not promote build-up, and is ideal for styrenes and most other plastic materials. For superior results, pre-cleaning of molded parts may be desirable.

ITEM NUMBER*

MRPS114

*Item numbers shown are for case of 12 cans.
To order individual cans add "CAN" to item numbers shown (e.g. MRFS514CAN).

BLANKET ORDER DISCOUNT:

Money-saving blanket orders reduce your inventory costs and permit maximum savings over a 12-month period. They are accepted provided the combined annual order totals 20 cases or more. Split shipments against blanket orders must be in quantities of 10 cases or more.

Hoist Rings – INCH

Whether you're hoisting an 800-pound mold base or a 15,000-pound piece of molding room equipment, DME Hoist Rings can add a margin of performance and convenience to the job at hand. The inherent danger posed by conventional static eyebolts (side-load breakage and hook disengagement) combined with stricter safety regulations make DME Hoist Rings an important addition to any mold shop or molding plant. Unlike eyebolts, these Hoist Rings will not yield to heavy side loads within their rated capacity and can pivot 180° and swivel 360° to compensate for pitch, roll and sway when lifting heavy, unbalanced loads. As with all mechanical devices, regular inspection for wear, and strict adherence to installation and operating guidelines is necessary to prevent failure due to misuse.

- Safer and stronger than conventional eyebolts
- Pivots and swivels to compensate for pitch, roll and sway when lifting heavy or unbalanced loads
- Prevents accidents caused by eyebolt breakage or lifting hook disengagement
- Will not yield to heavy side loads when used in accordance with manufacturer's instructions
- Manufactured from high-quality alloy steel (certified heat treatment)
- Meets or exceeds MIL-STD-1365 (OR-11) and MIL-STD-209C
- Seven sizes to handle loads from 800 to 15,000 pounds
- Safety factor is 5 times the rated load capacity in any direction

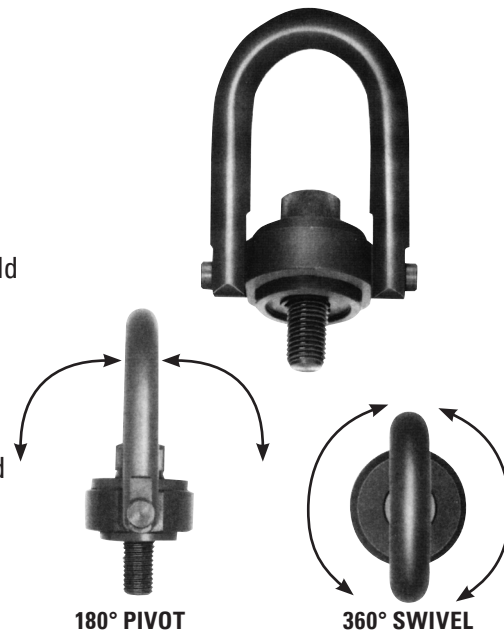

See what happens when heavy side loads are applied to a conventional eyebolt.

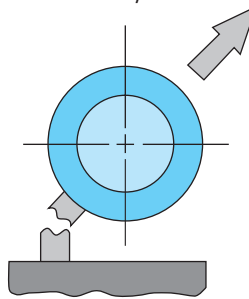

EXCESSIVE SIDE LOADS CAN CAUSE BOLT FAILURE.

The same load applied to a DME Hoist Ring is translated into a primary tension load at the bolt and normal to the bolt axis.

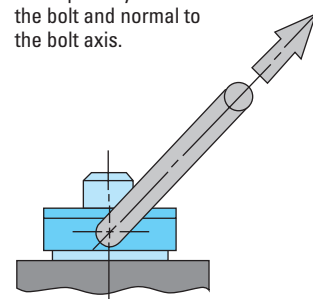

HIGH-TENSION LOADS ARE WELL WITHIN THE DESIGNED SAFETY LIMITS OF THE STRESSED HOIST RING.



Hoist Rings – INCH Installation and Ordering Information

Installation Data

Tap workpiece for hoist ring bolt with axis vertical to mounting surface. Work surface should be flat and smooth to provide full 360° flush seating for the bushing flange. For installation in ferrous materials, the screw should be tightened to the full torque loading recommended in column TL below, +25% – 0.

(SAFETY NOTE: Some loosening may develop after prolonged service in a permanent installation. It is advisable to periodically retighten the mounting bolt to maintain the specified torque value.)

For maximum safety with soft metal workpieces such as aluminum, use extra length bolts with minimum effective thread engagement of 2 times thread diameter. The use of free fit spacers between the bushing flange and mounting surface is not recommended, as this will reduce the safe load rating on angularly applied loads. Hoist ring must be free to swivel 360° and pivot 180° at all times.

Material: Alloy steel (certified heat treatment), black oxide
Safety Factor: 5 times rated load in any direction
Range of Movement: 360° swivel; 180° pivot
Dimensions: Shown in inches (in)

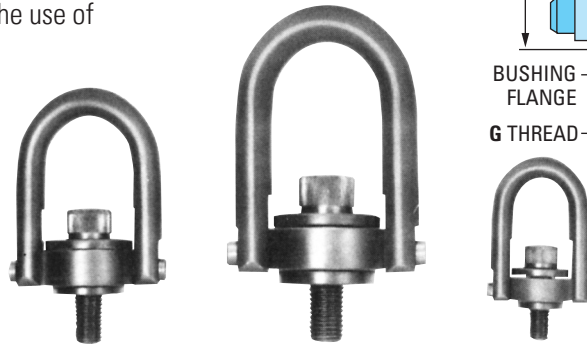
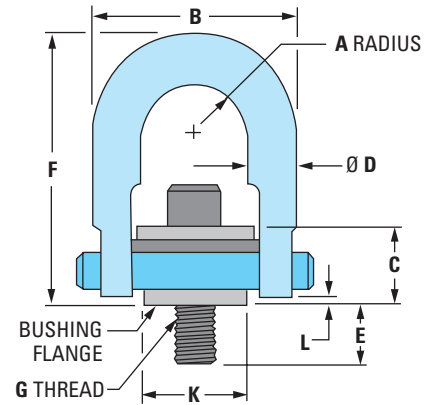
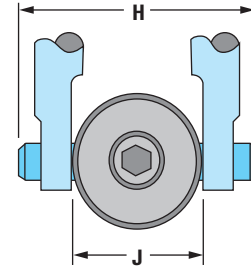

NOTE: Additional hoist ring sizes and bolt lengths (including metric versions) are also available on request.

Hoist Rings – SHR (includes bolt and retaining ring)

ITEM NUMBER	RATED LOAD (LBS)	A RADIUS	B	C	Ø D	E EFFECTIVE THREAD PROJECTION	F	G	H CLEARANCE DIMENSION	J	K	L	TL** FOOT LBS	WEIGHT
SHR0001	800	7/16	1 5/8	41/64	3/8	9/16	2 5/8	5/16-18	2	1	3/4	3/32	7	5 OZ.
SHR0002	1,000	7/16	1 5/8	41/64	3/8	9/16	2 5/8	3/8-16	2	1	3/4	3/32	12	5 OZ.
SHR0003	2,500	7/8	3 1/4	1 5/32	3/4	3/4	4 3/4	1/2-13	3 5/8	2	1 1/2	3/32	28	2 LB. 5 OZ.
SHR0004	4,000	7/8	3 1/4	1 5/32	3/4	1	4 3/4	5/8-11	3 5/8	2	1 1/2	3/32	60	2 LB. 7 OZ.
SHR0005	5,000	7/8	3 1/4	1 5/32	3/4	1	4 3/4	3/4-10	3 5/8	2	1 1/2	3/32	100	2 LB. 9 OZ.
SHR0006	10,000	1 13/32	4 13/16	1 11/16	1	1 1/2	6 1/2	1"-8	5 1/8	3	2 5/16	17/64	230	7 LB.
SHR0007	15,000	1 3/4	6	2 1/8	1 1/4	1 7/8	8 3/4	1 1/4-7	6 1/2	3 3/4	3 1/4	11/32	470	14 LB.

**Recommended torque load +25% – 0

Replacement Bolt Kits – SHK (includes bolt and retaining ring)

ITEM NUMBER	USED WITH	SIZE	E
SHK0001	SHR0001	5/16-18 X 1 1/4	9/16
SHK0002	SHR0002	3/8-16 X 1 1/4	9/16
SHK0003	SHR0003	1/2-13 X 2	3/4
*SHK0004		1/2-13 X 2 1/4	1
SHK0005	SHR0004	5/8-11 X 2 1/4	1
*SHK0006		5/8-11 X 2 1/2	1 1/4
SHK0007	SHR0005	3/4-10 X 2 1/4	1
*SHK0008		3/4-10 X 2 3/4	1 1/2
SHK0009	SHR0006	1"-8 X 3 1/4	1 1/2
*SHK0010		1"-8 X 3 3/4	2
SHK0011	SHR0007	1 1/4-7 X 4	1 7/8



NOTES:

E = Effective Thread Projection

Bolts not marked with an asterisk () are identical to those supplied with hoist rings. Bolts marked with an asterisk are longer, to provide thread projection of twice the bolt diameter, recommended for use with softer metals.

Mold Clamps

MOLD CLAMPS FOR PLASTICS MOLDS

Forged from Hi-tensile steel and thru-hardened. The design features a hardened no-turn washer and a shape and range of sizes that permit universal application for any mold.

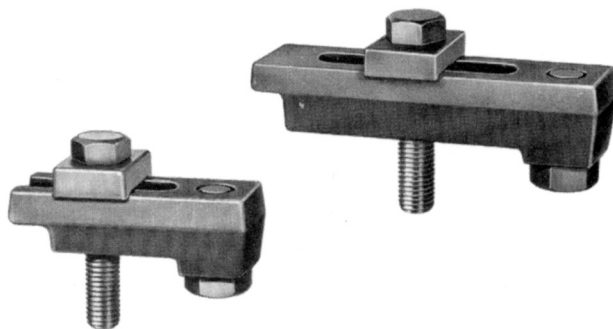

ITEM NO'S. MCA44 TO MCA67

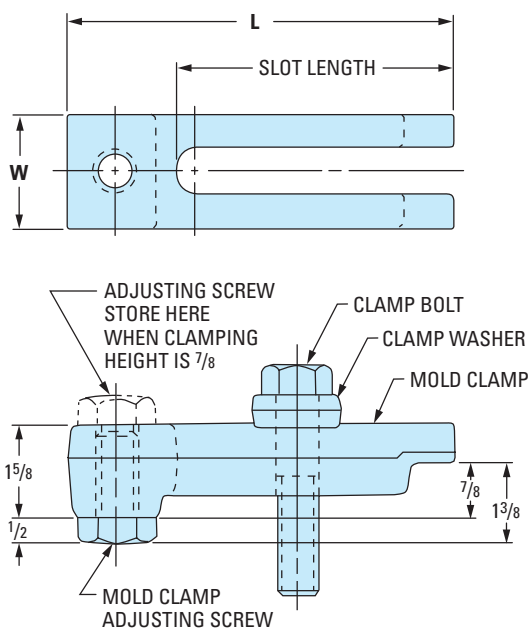

ITEM NO. MCA895

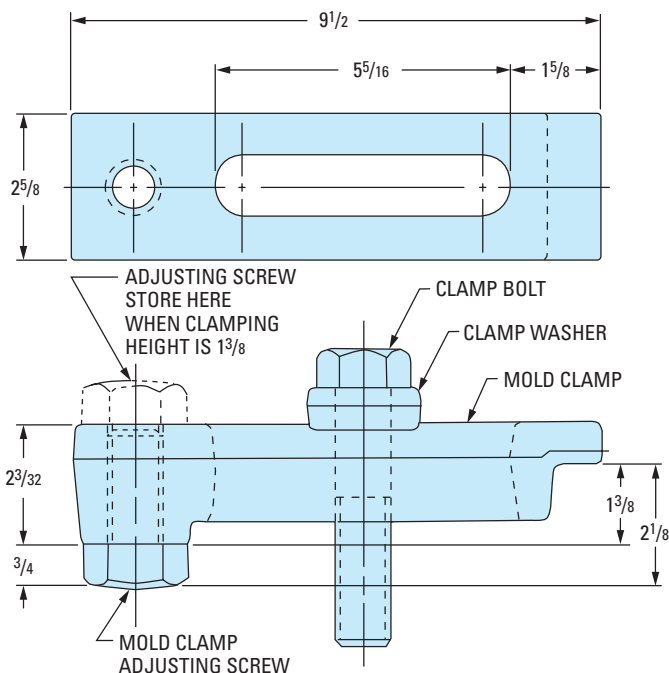

Mold Clamps for Plastics Molds (MCA)

ITEM NUMBER	CLAMP DIMENSIONS			CLAMP SCREW SIZE* THD. x LENGTH	REPLACEMENT PARTS	
	L LENGTH	W WIDTH	SLOT LENGTH		CLAMP BOLT AND WASHER KIT	ADJUSTING SCREW
MCA44	4 ³ / ₁₆	1 ⁵ / ₈	2 ¹³ / ₁₆	1/2-13 x 3"	MCK4	MCAS5
MCA55	5 ³ / ₁₆	1 ⁷ / ₈	3 ³ / ₈	5/8-11 x 3 1/2"	MCK5	MCAS6
MCA57	7	1 ⁷ / ₈	5	5/8-11 x 3 1/2"		
MCA65	5 ³ / ₁₆	2	3 ³ / ₈	3/4-10 x 3 1/2"	MCK6	MCAS8
MCA67	7	2	5	3/4-10 x 3 1/2"	MCK8	
MCA895	9 1/2	2 5/8	5 5/16	1-8 x 4 1/2"		

Mold Assembly consists of:

- 1 – Mold Clamp
- 1 – Clamp Washer
- 1 – Clamp Bolt
- 1 – Mold Clamp Adjusting Screw

***NOTE:**

Mold Clamp Screws supplied with assembly are of high-tensile strength alloy steel. Lengths shown will accommodate clamping ledges up to a maximum of 1.375. For clamping ledges in excess of 1.375, use longer screws accordingly.

Jiffy-Tite® Connector Seals | Seal Removal Tool Kit & Wrenches | Heater Puller (with snap ring)

Jiffy-Tite® Connector Seals

For Replacement in Either Jiffy-Tite or Jiffy-Matic Sockets

Jiffy-Tite and Jiffy-Matic Sockets are supplied with Viton seals for use with air, water or heat-transfer oil applications that do not exceed 400°F and 200 psi. Seals should be replaced periodically as required to ensure leak-free connections.

MAXIMUM OPERATING TEMPERATURE/PRESSURE = 400°F/200 PSI			
FOR USE WITH	SEAL MATERIAL (I.D. COLOR)	ITEM NUMBER*	USED WITH SOCKETS
AIR, WATER OR HEAT TRANSFER OIL	VITON (GREEN)	P2008	JS204(V/SV) TO 226(V/SV)
		P3008	JS306(V/SV) TO 328(V/SV)
		P5008	JS504(V) TO 526(V)

*Packs of 10 (sold in packs of 10 only).

Jiffy-Tite® Seal Removal Tool Kit – JSTK

The Jiffy-Tite Seal Removal Tool Kit can be used for removal of connector seals from Jiffy-Matic Sockets (including SV Series). Can also be used with Jiffy-Tite Sockets to provide easier seal removal.

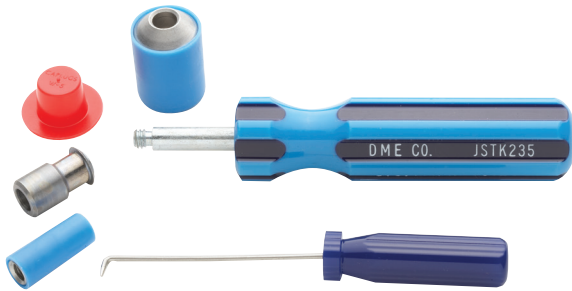

Includes handle, interchangeable tools for all socket sizes, seal pick and vinyl storage pouch.

ITEM NUMBER

JSTK235

NOTE: This tool kit is not required for “the original” or current line of Jiffy-Matic Sockets with removable hose stems.

Jiffy-Tite® Wrenches – SJP

For Jiffy-Tite Male, Female and Extension Plugs and Jiffy-Matic SV Series Male Plugs

DME Jiffy-Tite wrenches are accurately made from selected alloy steel, heat-treated and chrome-plated. They are specially designed for servicing flush-mounted plugs.

JIFFY-TITE WRENCHES FOR MALE AND EXTENSION PLUGS			
HEX SIZE	SQUARE DRIVE	ITEM NUMBER	FITS PLUGS
7/16	3/8	SJP251	JP(B)250, 251
9/16	3/8	SJP252	JP(B)252(SV) JP(B)351, 352(SV)
1 1/16	3/8	SJP253	JP(B)253(SV) JP(B)353(SV)
7/8	3/8	SJP354	JP354(SV)
7/8	1/2	SJP554	JP553, 554
1 1/8	1/2	SJP556	JP556



Heater Puller (with snap ring)

Provides trouble-free removal of Shoulder-Style Cartridge Heater.

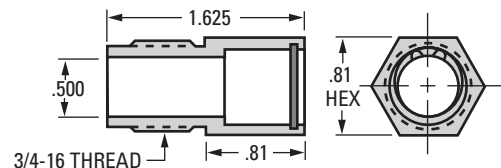

Puller with Ring

ITEM NUMBER

EHP0250

Replacement Snap Rings

ITEM NUMBER**

EHP0001

**Packs of 25.

DME Molding Supplies

The Best of Northern Supply, Nickerson and OHS

DME Molding Supplies combines three great companies – Northern Supply, Nickerson and OHS – into one comprehensive, convenient source for high-quality, economical products.

Our worldwide sourcing and purchasing power provides you with the broadest array of great products at affordable prices. We're also bringing new products to market more quickly than ever. And, with deep inventories at four locations across

North America, we can get you what you need fast.

Call toll-free to receive your copy of the DME Molding Supplies catalog, complete with dozens of new products, plus thousands of selections that have been favorites of our plastics processing customers for decades. In the U.S., call 800-626-6653; in Canada, phone 800-387-6600.

DME Molding Supplies is powered by DME Company, an essential mold technologies resource to customers worldwide.

In addition to offering the plastics industry's broadest range of market-leading products, DME provides unsurpassed knowledge, a global logistics infrastructure and exceptional service every step of the way. This support ensures that customers get the speed, accuracy and quality they need across DME's complete line of hot runner systems, control systems, mold bases and components, and moldmaking and molding equipment and supplies.

	<p>Drying Hoppers, Drawer Magnets, Storage Bins, Loaders, Tilters, Dumpers, Conveyors, etc.</p>		<p>Aluminum Manifolds, Flow Regulators, Ball Valves, Couplers, PVC Air & Water Hose, etc.</p>		<p>Insulated Heaterbands, Thermocouples, Thermometers, DIN Controllers, etc.</p>
<p>Auxiliary Equipment</p>	<p>Plumbing Products</p>	<p>Heaters and Sensors</p>			
	<p>Ceramic Knife, Sprue Pullers, Gatecutters, Electric Nippers, Mold Hammers, etc.</p>		<p>WD-40, Silicone Mold Release, Supergrease, Mold Cleaner, Anti-Seize, etc.</p>		<p>Screw Tips, Nozzle Bodies, Machine Mounts, Mold Clamps, Shutoff Nozzles, etc.</p>
<p>Cutter and Hand Tools</p>	<p>Releases and Lubricants</p>	<p>Machine Parts</p>			

Auxiliary Equipment

DRYING HOPPERS

Fully insulated, modular, stainless steel construction DRI-AIR's Modular Hoppers assure uniform material flow with: NO channeling, NO feedout problems, NO mixing problems, NO thru-put problems

- Standard capacity hoppers range from 5 to 600 lbs
- Dries less than a full hopper
- Dries material to the bottom of the slide gate
- Easy-to-clean diffuser cone directs air/material flow
- Hoppers include: slide gate, blank mounting adapter, access door (RH60 and over), insulation
- Laser-cut access doors provide a smooth, tight fit and eliminate troublesome gaskets
- RH400 & RH600 hoppers include full length sight glass and Bunting™ no-spill slide gate



STORAGE BINS

Ideal for storage and transfer of material from grinders, surge bins, bags, drums or gaylords

- Mobile
- Self-emptying
- Durable one-piece reinforced lid suitable for mounting equipment
- Lightweight
- Stackable
- Stainless steel slidegate
- Vacuum wand access tube
- Heavy-duty welded steel frame
- Forklift channel
- Locking casters



LOADERS, TILTERS AND DUMPERS

Loaders – designed to feed pellets, granules, and free flowing powders into an overhead hopper or storage vessel. Built with a variety of auger sizes and types and can deliver from 10 to 500 cu. ft. of material/hour.

- Direct gear drive for lower maintenance
- 20 cu. ft hopper capacity
- Quick disconnect auger for easy cleaning
- 45° or 60° auger slope



Tilters – designed to assist in the vacuum unloading of gaylord containers. The automatic tilting feature allows complete removal of material from the container. The adjustable regulator permits setting initial lift at any desired weight.

- 1" Pillow block pivot bearings
- Double convoluted industrial air bag – set up so bag cannot get overstressed!
- Automatic or manual tilt action
- Flow control to adjust operating speed

Box Dumpers – built to handle the tough unloading jobs! Standard unit capacity is 2,500#, larger capacities are available. The box retainer is adjustable from 32" to 48", plus there's also a permanent safety retainer bar! Push button controls permit stopping the unit at any point in the cycle for added control and safety.

- 52" wide bucket available!
- Custom width bodies – for large or awkward containers, increased lift capacity
- Custom discharge chutes

...AND MUCH MORE

Thousands of auxiliary items available beyond these popular featured products. DME Molding Supplies offers a wide variety of other high-quality, low-cost auxiliary products, including conveyors, water and oil filters, hydraulic pumps, chillers, cooling towers, end-of-arm tooling, and much, much more.



Plumbing Products

ALUMINUM MANIFOLDS

Aluminum Manifolds offer many advantages over welded steel or pipe manifolds. These manifolds have no welds or seams of any kind and cannot rust, they will offer many years of trouble-free service. The heavy wall extrusion will withstand extreme abuse and the round center hole permits easy cleaning. We will custom make manifolds to your dimensions in just a few days.

- Rated to: 1000 PSI – air;
3000 PSI – hydraulic
- Heavy wall extruded 6061 aluminum
- No welds! No rust!
- Very low cost
- Easy to clean



FLOW REGULATORS

Provide a unique, leak-free, singlepoint manual flow control. Incorporates the proven mechanical flowmeter and integral needle valve in a compact design. Very few moving parts improve reliability and leak-free operation. Brass valve, EPDM O-rings, and polysulfone viewing window are compatible with most process liquids. Brass quick-connect fittings are available.

- Compact size works well in restricted-space locations
- Rugged construction gives years of dependable service
- 240°F (115°C) temperature rating allows installation into a wide range of applications
- Optional temperature gauge displays additional process information
- No mounting restrictions – ease installation in any position without extra brackets or hardware



HYDRAULIC COUPLERS

Double side shut off poppet type in Steel, Stainless Steel and Brass. Available with Buna-N or Viton seals.

Hardened nipples and sleeves and solid barstock construction assure a long service life providing maximum resistance to hydraulic shock and abuse common in industrial applications.

- Steel Body – body, sleeve and valve are zinc plated steel
- 303 Stainless Steel – body, sleeves, valves, retaining rings, springs and locking balls are stainless
- Brass body – body, sleeve and valves are brass



PVC AIR & WATER HOSE

- Clear, red or blue
- Tough yet lightweight
- Very flexible
- Highly abrasion resistant
- Food grade PVC
- Resistant to most chemicals
- Temperature range:
-20° to 150°F (-5° to 65°C)



FORGED BRASS BALL VALVES

- Super-port BBV-MF is a full port 2-piece ball valve with features only found on more expensive valves
- Extra heavy-duty bottom-loaded stem with a TPE thrust washer and Viton O-ring
- TPE seats, thrust washer and stem packing
- Self cleaning chromium plated brass ball for maximum durability



...AND MUCH MORE

Thousands of plumbing items available beyond these popular featured products. DME Molding Supplies offers a wide variety of other high-quality, low-cost plumbing products, including brass and steel hydraulic pipe, high-flow cascade assemblies, pipe elbows and fittings, hose assemblies, and much, much more.



Heaters and Sensors

MICA INSULATED HEATERBANDS

Time tested materials & manufacturing techniques make this heater a proven, economical, reliable performer.

- 1- and 2-piece bands
- Fiberglass leads, stainless leads and post terminals
- 120 and 240 volt styles
- Uniform heat, high-watt density
- Custom bands available in rush and standard time options

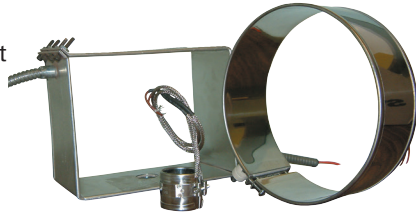

CARTRIDGE HEATERS

- A superior for use where high watt densities, high temperatures and long life are required
- Widely used throughout the industry as a rugged dependable heat source
- High-quality materials and craftsmanship

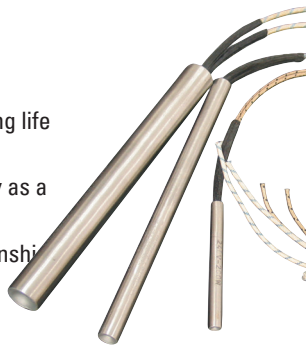

THERMOCOUPLES

Variable immersion depth of 1 $\frac{1}{4}$ " to 1 $\frac{3}{4}$ " with a tip length of 2 $\frac{1}{2}$ ". These will accommodate most requirements in either a straight or 90° bend. Off the shelf delivery and a very low price make our standard thermocouples just what you need. Also available in K & RTD types.



NON-CONTACT IR THERMOMETERS

Compact thermometer with wide temperature range

- Measures temperature from -58 to 1000°F with 0.1° resolution up to 199.9°
- Built-in laser pointer identifies target area
- 2000 counts backlit display
- Overrange indicator
- Automatic Data Hold when trigger is released
- Fixed 0.95 emissivity covers 90% of surface applications
- Auto power off
- Complete with 9V battery



ELECTRONIC COMPONENT REPAIR SERVICE

Quick repairs normally less than 10 working days. Cost savings. Total reliability, all repairs are fully load tested. One full year warranty on both printed circuit board repairs as well as on complete control repairs. We repair ALL types of industrial electronic controls: temperature controllers, programmable controllers, timers and counters, instrument and machine tool controls, AC and DC drives, thousands of new models added.

- Usually less than 1/2 the cost of a new controller
- We repair all types of controllers
- Fast, low-cost, warrantied repair by qualified specialists
- Over 60,000 schematics in our library

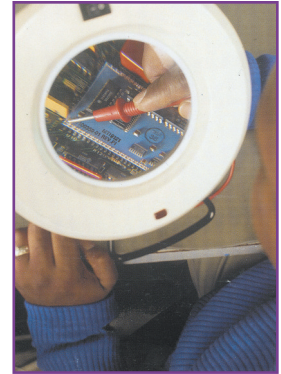

DIN CONTROLLERS

Single channel controllers include a universal sensor input with up to three outputs that can be programmed for heat or cool temperature control, or to operate as process or deviation alarms.

- Infrared communications
- Up to three outputs
- Ramp to set point
- Dual displays
- Variable Burst Fire – prolongs heater life



...AND MUCH MORE

Thousands of heating and sensor items available beyond these popular featured products. DME Molding Supplies offers a wide variety of other high-quality, low-cost heating and sensing products, including variable transformers, modular temperature controllers, wire and wire fittings, contactors, relays, and much, much more.

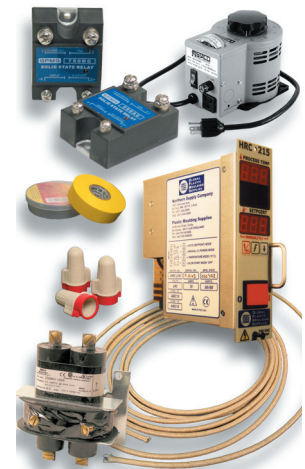

Cutter and Hand Tools

CERAMIC KNIFE

Heavy duty handle with Ceramix™ Q10 blade. Adjust the cutting angle between the blade and the material for best results and to prevent scratches. Flip blade for 2 types of jobs. OSHA Friendly! Even though ceramic blades remain sharp FAR longer than metal blades, it's practically impossible to cut yourself with them!

Unique Dual Blade Design!

- Cleans up to 6mm (0.236") sheets
- Cleans up to 4mm (0.157") sheets
- Cleans up surfaces



ELECTRIC NIPPERS

Just plug them in and they're ready for continuous use. Well balanced and comfortable to hold for many hand sizes.

- Weight 290g; AC power source (110v)
- Single stroke or continuous cut
- High speed and high power
- The blade opening and speed can be freely adjusted in the range of 2-5 times per second
- A control circuit is built into the body. Transformers or control box is not needed.



BRONZE SPRUE PULLERS

- Strongest forged bronze alloy – Ampco 45; Alloy 630; AMS 4640
- Non-scratch – ideal for removing sprues and parts without damaging mold surfaces
- Non-spark – for work around fuels, solvents, and other flammable chemicals
- Non-magnetic – for work around MRIs and magnets
- Corrosion Resistant – for work outdoors, marine use and corrosive environs
- Thermal insulating, soft touch foam grip – to reduce fatigue and CTDs
- Longer double ergonomic handles – for high leverage, less operator force
- Easily re-sharpened



MOLD HAMMERS

Mold Hammer with Interchangeable Tips

- Tips are removable and interchangeable
- Will not mar metal or plated finish
- Tips available in medium or hard vinyl, tough nylon, brass and steel
- Non-sparking
- Non-magnetic



GATECUTTERS

- 5 styles/sizes available
- Low-cost, high-quality
- Slim blade design
- Resharpens well
- Smooth action
- Spring is steel coil
- Very sharp
- Smooth flat cut
- Better than competitive gate cutters!



...AND MUCH MORE

Thousands of cutters and hand tools available beyond these popular featured products. DME Molding Supplies offers a wide variety of other high-quality, low-cost cutters and hand tools, including brass mold tools, sprue punches, nozzle wrenches, deburring tools, barrel brushes, hammers, blowguns, flashlights, and much, much more.



Releases and Lubricants

WD-40

■ Displaces Moisture.

Formulated for ultra-high surface attraction to metal. It completely covers surfaces, including microscopic irregularities, even in the presence of moisture. A non-conductor of electricity and quickly eliminates moisture-induced short circuits.

■ Penetrates.

Ultra-high surface attraction results in a super penetrating action that loosens rust-to-metal bonds and frees stuck, frozen, or rusted metal parts.

■ Protects.

Deposits corrosion-resistant ingredients over the entire surface area, including microscopic irregularities. This protective barrier shields against moisture and other corrosive elements.

■ Cleans.

Ultra-high surface attraction enables it to get under dirt, grime, caked grease, and oil to clean the surface at WD – the same time it forms a corrosion resistant barrier.

■ Lubricates.

Ultra-high surface attraction assures the lubricating ingredients will be widely dispersed and tenaciously held to all moving parts.



SLIDE NEXGEN METAL & MOLD CLEANER

Direct alternative to trichloroethylene and methylene chloride. Food approved. Leaves no oily residue. No global warming compounds. Not a hazardous air pollutant. Non-corrosive and not SARA reportable. Biodegradable and rinses with water. Meets tough health, safety and environmental regulations. High solvency for resins, polymers and dies. Formulated purely from citrus and vegetable products. It meets or exceeds the toughest health and safety issues, without sacrificing RAW CLEANING POWER. Biodegradable, it easily rinses away with water and leaves no residue.

- General cleaning and wiping
- Oil spill clean-up
- Ink, tar and adhesive removal
- Paint and graffiti removal
- Removing silicone and lithium grease
- Degreasing



SLIDE ECONOSPRAY 6 SILICONE MOLD RELEASE

Works efficiently on both cold and hot molds. It is CFC-free and free of chlorinated solvents. Econo-Spray® Silicone imparts a smooth, dry film, which is FDA approved and USDA approved for food machinery. Operating temps: 35°F – 600°F

- No ozone depleting chemicals
- Non-chlorinated
- No methylene chloride
- No Chlorofluorocarbons (CFCs)
- Safe on solvent-sensitive plastics



COPPER & NICKEL ANTI-SEIZE

- Will not bleed, separate or harden
- Choose copper or nickel base
- Copper rated to 2000°F
- Nickel rated to 2800°F
- Eliminates galling and seizing
- Suggested for nozzles, screw tips, cylinder bolts, mold clamps, etc.



SLIDE SUPERGREASE

Colorless. Odorless. Non-toxic. FDA dielectric. Contains TPF. Will not freeze, melt, gum up. Compatible with other lubricants No silicones. Will not wash out. USDA listed H1. Repels water. Will not separate, run or fall out. Thixotropic properties provide excellent mechanical stability when sudden temperature changes occur. Exceptional load-bearing properties. Clear, clean, non-yellowing grease. For injection molds, mold assemblies, especially medical and food grade plastic parts. Prevents corrosion. Oper. temps: -65° to +650°F



...AND MUCH MORE

Thousands of auxiliary items available beyond these popular featured products. DME Molding Supplies offers a wide variety of other high-quality, low-cost releases /lubricants /cleaners, including RTV silicone, GoJo® Hand cleaners, Boltlockers, Metal Polish, TPF thread sealant (both liquid and tape), and much, much more.



Machine Parts

SCREW TIPS

Top quality general purpose 3-piece Screw Tip of the Free-Flow design. Suitable for most molding applications including moderately abrasive or filled materials. Much tougher and longer lasting than standard OEM or H-13 Screw Tip. Manufactured from a combination of steels that provide wear-resistance in components subject to wear plus toughness and torque resistance in components subject to these stresses. Through hardened and Nitrided for long service.



MACHINED MOLD CLAMPS

Machined Mold Clamps fit $1\frac{15}{32}$ " $2\frac{29}{32}$ " or $1\frac{3}{8}$ " mold flanges and can be inverted for other size flanges.

- Low cost
- Nice finish
- Machined accuracy
- Versatile fit and design



NOZZLE BODIES

- Made of high-quality 4140 tool steel
- Holds removable tips
- Extension tips and dispersion tips
- Externally heated



MACHINE MOUNTS

UNISORB Quantum IM Mounts provide optimum leveling and alignment in minutes, without anchoring either the machine or mounts to the floor. Designed especially for injection molding and die casting machines, UNISORB Quantum IM Mounts dampen both vertical and horizontal impacts found in reciprocating machines. UNISORB Quantum IM Mounts meet applicable OSHA requirements.

- Increased equipment life
- Simplified machine installation
- Fast, accurate alignment
- Reduced shock and vibration
- Elimination of anchor bolts
- Uneven floors accommodated
- Machine "walking" prevented



SHUTOFF NOZZLES

EXTERNAL SPRING – external spring activated shut-off pin.

SHUT-OFF PIN – externally activated shut-off pin permits unrestricted material flow during injection.

REPLACEABLE TIP – special hardened tool steel tip can be changed in seconds.

AUTOMATIC OPERATION – operation is fully automatic and mechanical.

- Completely mechanical, automatic operation
- No internal springs
- Eliminates cold slugs
- Controllable back flow during injection
- Reduces flashing
- Precise pressure control during cure
- Positive shut-off prevents drooling

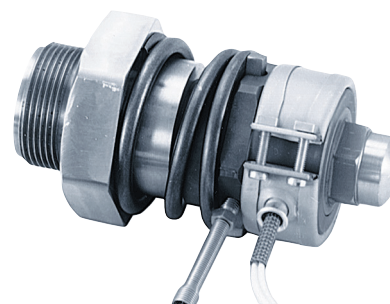

...AND MUCH MORE

Thousands of machine parts available beyond these popular featured products. DME Molding Supplies offers a wide variety of other high-quality, low-cost machine parts, including mixing nozzles, locating rings, sprue bushings, socket head cap screws, hoist rings, and much, much more.

