

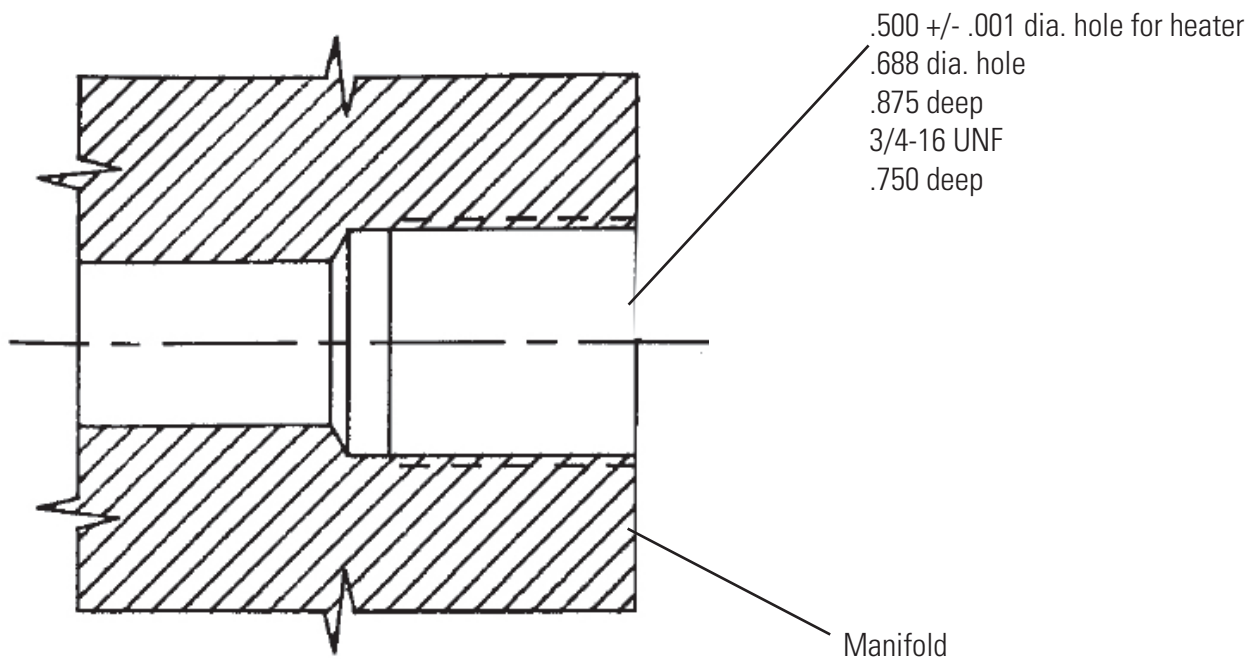

29111 Stephenson Hwy.
Madison Heights, MI 48071 USA
800-626-6653

HEATER PULLER INSTALLATION DATA

Please read carefully before installing components



NOTES:

1. Drill and tap the manifold as shown.
2. Clean heater hole.
3. Apply anti-seize compound on the heater puller threads and assemble into manifold.
4. Assemble 1/2" dia. DME cartridge heater into heater puller.
5. Place snap ring into slot to hold cartridge heater.